

CS FILTER

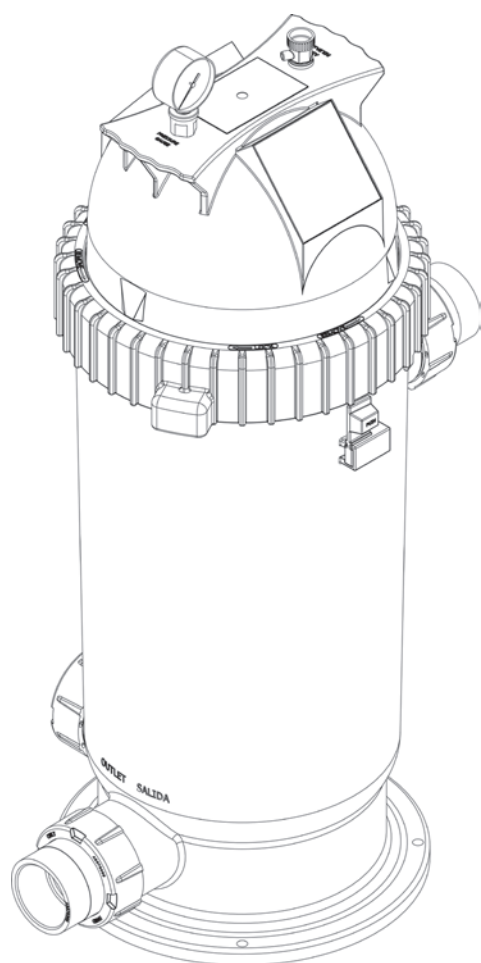

Instructions for installation and use
English

EN

More documents on:
www.zodiac-poolcare.com

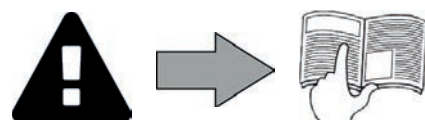

WARNINGS

- Failure to respect the warnings may cause serious damage to pool equipment or cause serious injury, even death.
- This appliance is intended for a specific pool use and must not be used for any purpose other than that for which it was designed.
- It is important that the equipment is operated by competent and qualified (both physically and mentally) people who have previously received instruction in its use. Any person not meeting these criteria should not go near the equipment, to avoid the risk of being exposed to dangerous components.
- Keep children away from the equipment.
- The device must be installed by a qualified technician according to the manufacturer's instructions and in compliance with local regulations. The installer is responsible for installation of the equipment and for compliance with national installation regulations. Under no circumstances can the manufacturer be held liable in the event of failure to comply with applicable local standards.
- Incorrect installation and/or use may cause serious damage to property or serious injury (possibly even death).
- Any equipment, even carriage and packing paid, travels at the consignee's risk. If there is evidence of damage occurring during transport, the recipient should note the fact on the carrier's delivery note (and confirm in writing to the carrier by recorded delivery letter). In the event of a device containing coolant that tipping over, state your reservations to the carrier in writing.
- If the appliance suffers a malfunction, do not try to repair it yourself; contact a qualified technician.
- Refer to the warranty conditions for details of the permitted water balance values for the operation the equipment.
- Removing or shunting out one of the safety devices automatically voids the warranty, as does using replacement parts not manufactured by ourselves.
- Do not spray insecticide or any other chemical (flammable or non-flammable) in the direction of the equipment, as this may damage the body and cause a fire.
- Do not immerse the equipment in water or mud (with the exception of cleaning robots).
- Pressurized air in filter systems can cause product failure or also cause the filter lid to be blown off which can result in death, serious personal injury, or property damage. Be sure all air is out of system before operating or testing the equipment.
- Maximum operating pressure of the filter is 3.5 bar (50 psi). Never subject the filter to any operating pressure exceeding 3.5 bar (50 psi).
- Never attempt to disassemble the filter when filtration pump is running.



EN

Recycling







This symbol means that your appliance should not be disposed of with other rubbish. It should be selectively sorted so that it can be re-used, recycled or transformed. If it contains any substances that may be harmful to the environment, these will be disposed of or neutralised.

Contact your retailer for recycling information.



- Before you do anything with the device, it is vital that you read this installation and user manual, as well as the "warnings and warranty" booklet delivered with the device. Failure to do so may result in material damage or serious or fatal injury and will void the warranty.
- Save these instructions during the device's life time.
- It is prohibited to distribute or modify this document in any way without authorisation from Zodiac®.
- Zodiac® is constantly developing its products to improve their quality; therefore, the information contained in this document may be modified without notice.

CONTENTS

	1 Specifications	3
	1.1 Description	3
	1.2 Technical specifications	3
	1.3 Dimensions and markings	4
	1.4 Graphs showing loss of head depending on flow rate	4
	2 Installation	5
	2.1 Selecting the location	5
	2.2 Hydraulic connections	6
	3 Use	7
	3.1 Operating principle	7
	3.2 Operation	7
	4 Maintenance	8
	4.1 Winterizing	8
	4.2 Maintenance	8
	5 Troubleshooting	10



Tip: to make it easier to contact your retailer

- Write down your retailer's contact details to help you find them more easily and fill in the "product" information on the back of the manual; your reseller will ask you for this information.



1 Specifications

1.1 I Description

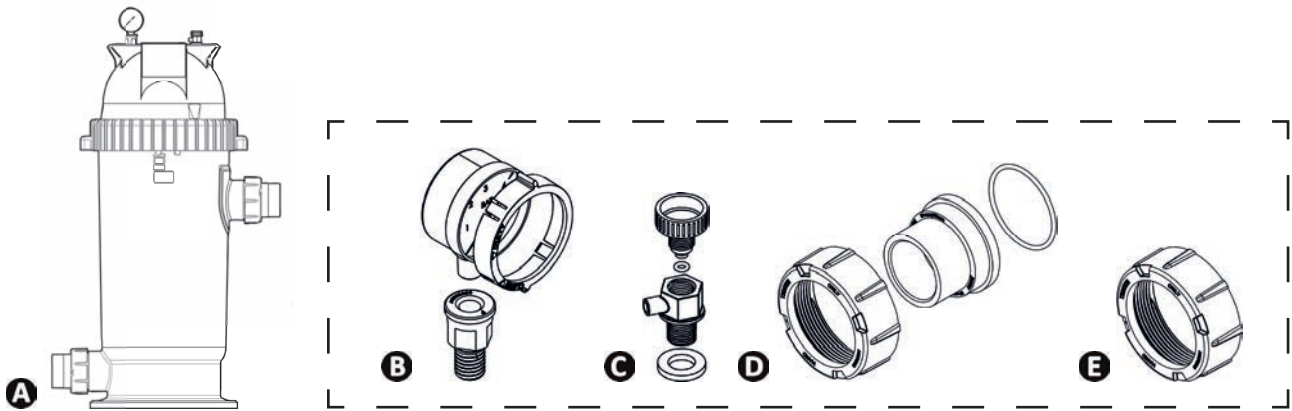

A	CS filter
B	Pressure gauge + adapter + seal + "CLEAN-DIRTY" ring x 1
C	Air release + seal x 1
D	2 x 63/50 mm dia. union coupling + seal x 2
E	63/50 mm dia. union x 1

EN

1.2 I Technical specifications

	Unit	CS 100	CS 150
Operating water temperature		1 to 40°C	
Filter area	m ²	9.3	14.0
Maximum flow	m ³ /h	22.7	28.4
Filtration speed	m ³ /h/m ²	2.4	2.1
Maximum pool volume	m ³	130	170
Normal operating pressure	bar	0.4 - 1,2	
	psi	6 - 17	
Maximum pressure	bar	3.5	
	psi	50	
Filter size	µm	15-20	
Pipework connection diameter	mm	63/50 dia.	

1.3 I Dimensions and markings

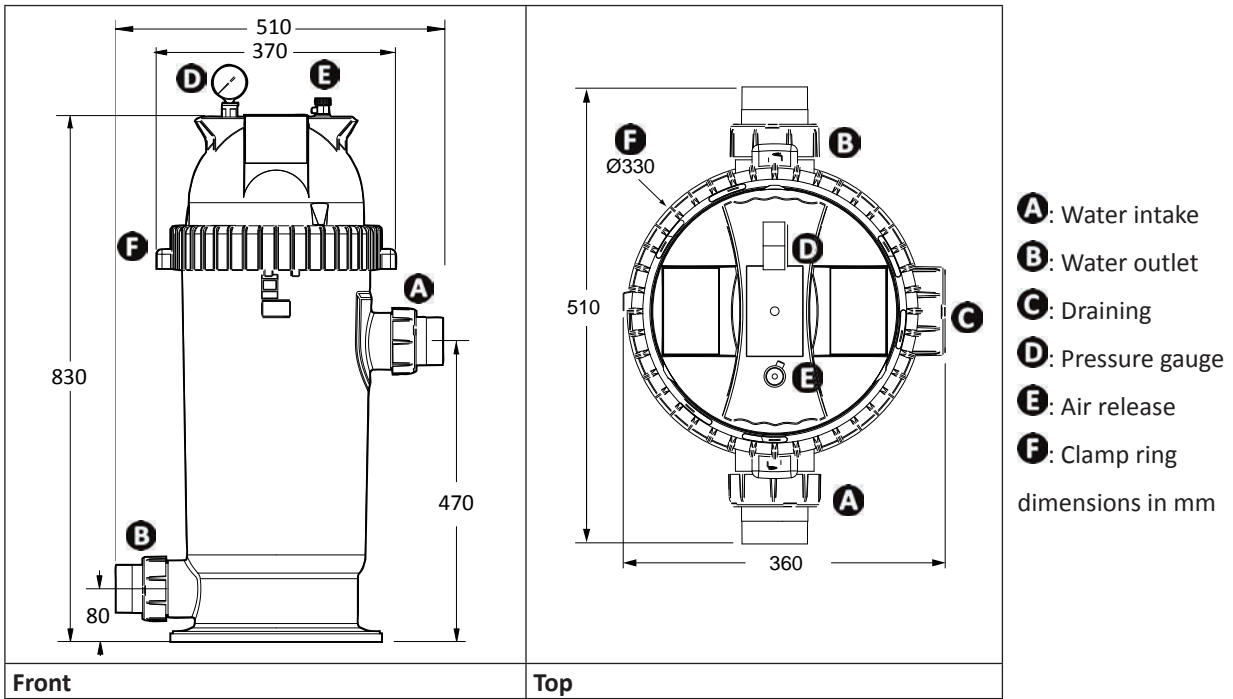

1.4 I Graphs showing loss of head depending on flow rate

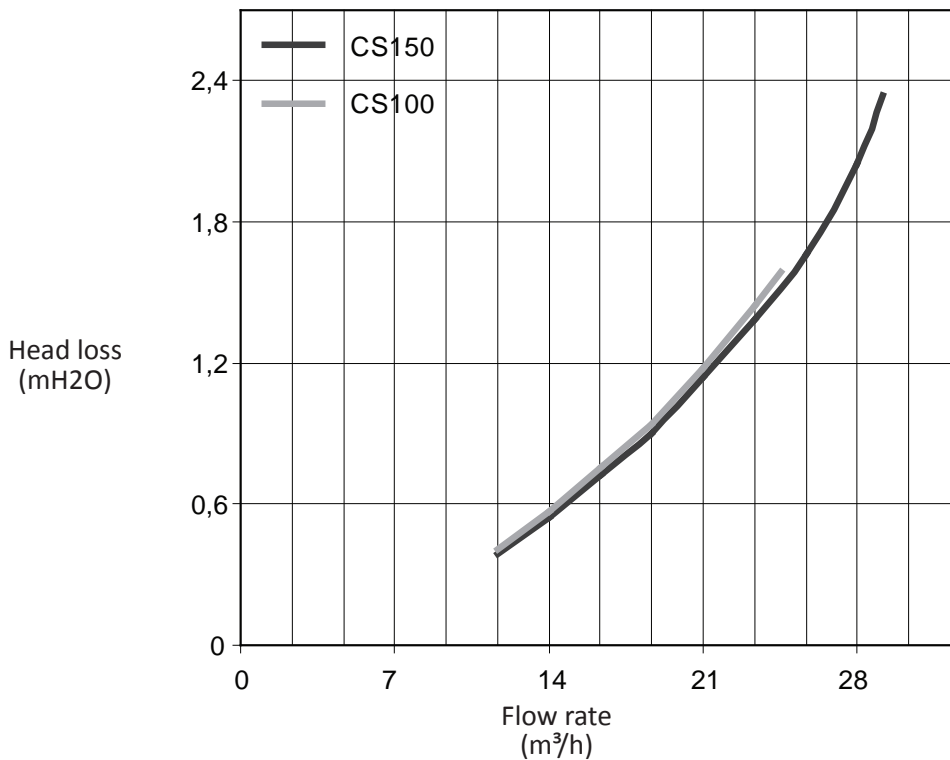



2 Installation

2.1 I Selecting the location

- The filter must be installed:
 - after the circulation pump,
 - before a heating and/or water treatment system,
 - ideally 0.5 m below the water level,
 - if it is to be installed indoors, it must be in a dry, well ventilated, frost-free equipment room.
- The filter must not be installed:
 - in an area subject to flooding, splashing, rain or exposed to direct sunlight.
 - more than 1.5 m above the water level.
 - near a heat source or inflammable gas,
 - in an equipment room where chemicals are stored, since any fumes could damage the filter.
- It should be easily accessible for doing work (cover, hydraulic connections, draining).
- Allow total vertical clearance of at least 1.35 m, in order to be able to open the filter and remove the cartridge easily.
- The hydraulic circuit prior to the filter must be as short as possible and have as few obstacles as possible (elbows, other devices), in order to prevent loss of head.
- Install on a stable, solid, level surface (e.g. concrete floor).
- Secure the filter to the ground using 6-8mm dia. x 60mm minimum stainless steel screws.
- Install electrical control at least 1.5 meter from the filter. This will allow enough room to stand away the filter during start-up.

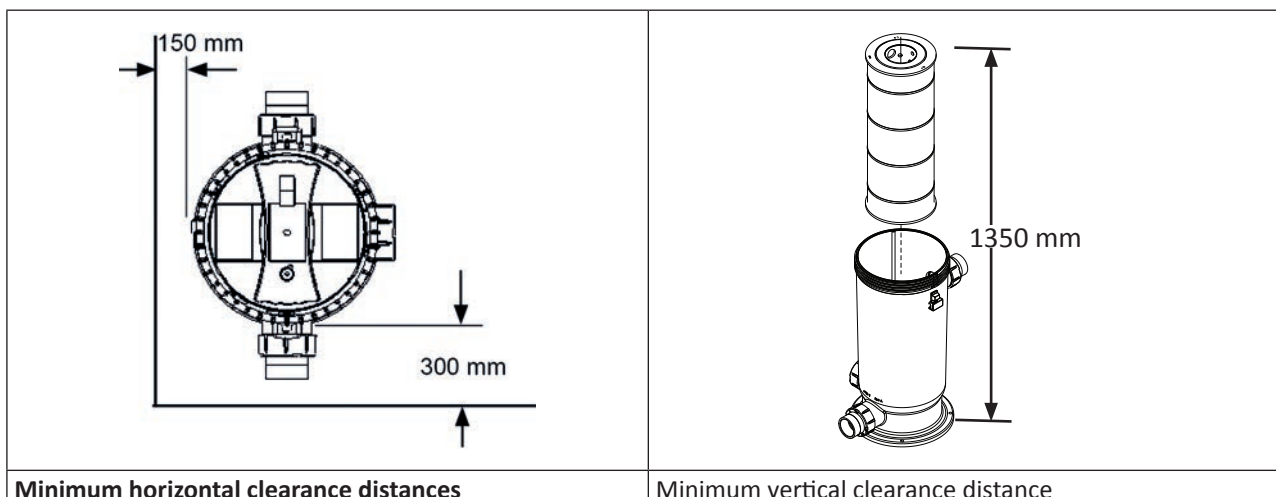

EN

2.2 I Hydraulic connections



- Respect the hydraulic connection direction (see para. "1.3 I Dimensions and markings").

- Loss of head graphs are available, para. "1.4 I Graphs showing loss of head depending on flow rate".
- Screw the AIR RELEASE into the cover in the marked location (there is a seal is fitted on the release mechanism).
- Screw the pressure gauge on to the adapter, using Teflon tape, then screw the assembly on to the cover in the "PRESSURE GAUGE" location (there is a seal is fitted on the adapter)

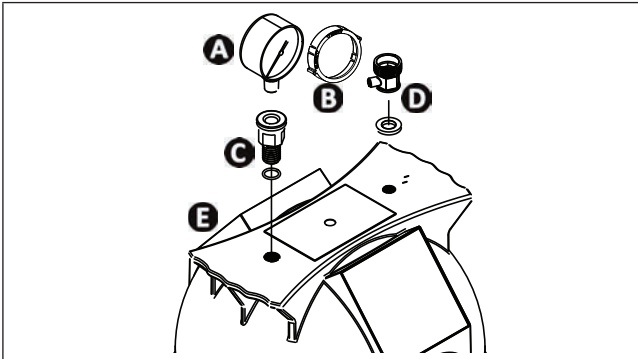

- A**: Pressure gauge
- B**: "CLEAN-DIRTY" ring
- C**: Pressure gauge adapter + seal
- D**: Air release + seal
- E**: Filter cover

- For hydraulic connections, use 63/50 mm glue-on union couplings (supplied).
- Install a non-return valve if the filter is installed above the water level.
- Install isolation valves on the filter suction and discharge, if it is installed below the water level.
- Avoid high points on the pipework for more efficient priming
- Check that the hydraulic couplings are correctly tightened and that there are no leaks.
- Pipes must be supported to prevent any risk of breakage due to the weight of water.

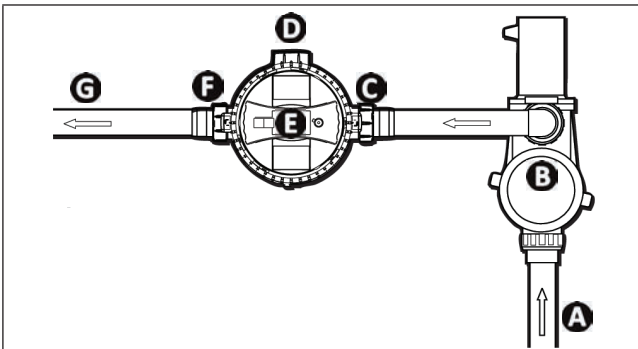

- A**: pool water suction
- B**: pump
- C**: filter water intake
- D**: filter drain
- E**: filter
- F**: filter water discharge
- G**: pool water discharge

Tip: Versa Plumb® kit

- In the event that a CS filter is installed jointly with a Zodiac® pump from the FloPro™ range, it is recommended that you use the optional Versa Plumb® kit. Its use simplifies the installation and optimises the flow.

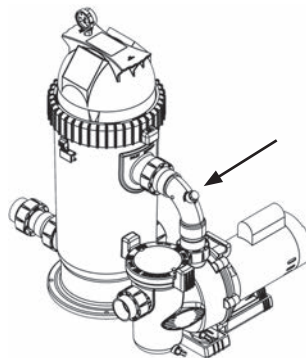

Tip: connect the filter-drain to a nearby draining system

- An additional 63/50 dia. tailpiece is supplied for connecting the filter drain to a nearby drainage system, if necessary.
- Note: if the filter is connected to a nearby drainage system, it is essential to add a valve downstream which can be opened during drainage of the filter and closed at all other times to prevent backflow into the filter.



3 Use

3.1 | Operating principle

The filter is essential for a swimming pool since it contributes to water treatment and ensures its clarity. Water passes through the filter cartridge in the filter vessel and impurities are removed. The greater the accumulation of impurities, the more the pressure in the filter will increase. When switching on the system, mark the normal operating pressure with the "CLEAN-DIRTY" ring on the pressure gauge. when the pressure reaches +0.7 bar (10 psi) above normal operating pressure, the cartridge must be cleaned.

3.2 | Operation



- To prevent any risk of explosion that might cause damage to equipment, serious injury or even death, make sure that the hydraulic circuit is free of any debris or blockage and is not subject to excessive pressure and that the filter lid locking ring is properly installed.
- Ensure that all valves are open and/or that the power of the filter pump is suitable for the size of the filter if the initial pressure is greater than 1.2 bar (17 psi).

EN

- The filter cover must be correctly tightened and its seal clean and in place (on the clamping ring inside the cover). If necessary, apply a silicone based lubricant to facilitate installation.
- Check that the hydraulic connectors, ground fixing screws, etc. are correctly tightened,
- Ensure that the filter is properly stable; it should be level.
- The hydraulic circuit must be bled and not contain any foreign bodies.
- Open the valves.
- Open the air release on the filter cover.
- Stand clear of the filter and start the pump.
- When the water level in the filter is at maximum, water escapes through the air release, which should then be closed.
- Check that there are no leaks on the hydraulic circuit.
- Place the "CLEAN" arrow on the pressure gauge "CLEAN-DIRTY" ring on the value for the initial pressure in the filter. The pressure should not exceed 1.2 bar (17 psi).



The "CLEAN" arrow position indicates the filter's initial operating pressure and that the filter cartridge is clean.



Tip: installation with a variable speed pump

- For an installation with a variable speed pump, it is normal to have low initial pressure if the filtering speed is low, and vice versa. In such a case, always use the same filtering speed as a comparison reference for the "CLEAN-DIRTY" indication.



4 Maintenance

➤ 4.1 I Winterizing



- **If there is a risk of frost, the filter must be winterized. If the filter freezes, severe damage may be caused and the warranty invalidated.**

- Drain the filter (see para. "4.2.2 Drain the filter") and the hydraulic circuit (pump, pipework), following the manufacturer's instructions.
- If necessary, cover the equipment with a tarpaulin to protect it against the weather.

➤ 4.2 I Maintenance



- **It is recommended that the equipment is fully serviced at least once a year to ensure proper operation, maintain performance levels and possibly prevent potential failures. These operations are carried out by a technician and are chargeable.**

4.2.1 User maintenance

- Clean the outside of the equipment; do not use solvent-based products.
- Check the filter pressure and the condition of the pressure gauge and the air release once a week (clean the filter cartridge; see para. "4.2.3 Cleaning or replacing the filter cartridge").
- Remove debris from the pump's pre-filter basket (see pump manual).
- Check that there are no leaks in the hydraulic circuit.

4.2.2 Drain the filter

- Switch off the filter pump.
- Close the isolation valves on the suction and discharge.
- Open the air filter bleed.
- Drain the filter by unscrewing the drain plug and opening the drain valve, where necessary.
- Replace the drain plug or close the drain valve, once the filter is empty of water.
- For return to service, see para. "3.2 I Operation".

4.2.3 Cleaning or replacing the filter cartridge

- When the pressure gauge needle is close to the "DIRTY" arrow, the filter cartridge should be cleaned.



The "DIRTY" arrow position indicates that the pressure in the filter has increased in relation to its initial operating pressure and that the filter cartridge is dirty.

- Change the filter (see para. "4.2.2 Drain the filter").
- Remove the filter cover by pressing the locking tab on the filter body and unscrewing the clamp ring in an anti-clockwise direction.
- Remove the filter cartridge by pulling it upwards.

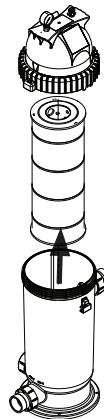

- Clean the filter cartridge with a hose pipe (do not use a high pressure jet), directing the water jet inside and then rinsing the outside. Use a soft brush, if necessary.
- To clean off algae, sun tanning oils and lime scale, soak the filter cartridge in a degreasing solvent and then in a descaler. Ask your retailer for the appropriate products.
- Once the cartridge is clean, replace it in the filter body or insert a new cartridge, if necessary.
- Push the filter cartridge firmly into its housing and ensure that the bleed pipe is properly located inside it (see para. "4.2.3 Cleaning or replacing the filter cartridge").
- Check the condition of the seal (on the clamp ring inside the cover). Replace it if it is damaged. If necessary, apply a silicone based lubricant to facilitate installation.
- Switch on the filter (see para. "3.2 I Operation").



Tip: cleaning the filter cartridge

- It is easier to clean a filter cartridge when it is dry. Simply tap it to remove most of the dirt. It can then be cleaned with water. In such a case, it may be worthwhile having a second cartridge, so that they can be alternated.

4.2.4 Cleaning the bleed pipe

- Drain the filter (see para. "4.2.3 Cleaning or replacing the filter cartridge").
- Remove the filter cover by pressing the locking tab on the filter body and unscrewing the clamp ring in an anti-clockwise direction.
- Check that the bleed pipe inside the reservoir is not obstructed; if necessary, remove it and unblock it.

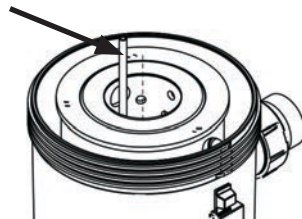



- Once the bleed pipe has been cleaned, replace it in the filter body and then replace the filter cartridge.
- Check the condition of the seal (on the clamp ring inside the cover). Replace it if it is damaged. If necessary, apply a silicone based lubricant to facilitate installation.
- Switch on the filter (see para. "3.2 I Operation").



5 Troubleshooting



- Before you contact your retailer, we invite you to carry out some simple checks for yourself in the event of a malfunction, using the following tables.
- If the problem continues contact your retailer.
-  : Actions only to be carried out by a qualified technician

The water is not clear.	<ul style="list-style-type: none"> • Perhaps there is not enough disinfectant or the water balance is incorrect. Check the water parameters (see "warnings and warranties" booklet supplied with the equipment). • The pool sees a lot of use. Check that the filtering time is sufficient for the pool's level of use. • The filter cartridge is dirty or holed. Clean or replace the filter cartridge (see para. "4.2.3 Cleaning or replacing the filter cartridge").
Filter pressure too low (see pressure gauge) / low flow	<ul style="list-style-type: none"> • The pump's pre-filter basket is full of debris; clean it. • Air leak in the circuit. Check that all joints are tight. • There is a blockage in the suction and/or discharge pipe. Check the hydraulic circuit. • Check the position of all valves in the hydraulic circuit. • There is a hole in the filter cartridge. Replace the filter cartridge (see para. "4.2.3 Cleaning or replacing the filter cartridge"). • The pump is not running quickly enough. Adjust the pump speed to achieve a sufficient flow (variable speed pump only). • The water level in the pool is too low. Fill the pool. • The pump is not primed. Re-prime it. •  The pump impeller and diffuser are blocked or worn. Replace them.
Filter pressure too high (see pressure gauge).	<ul style="list-style-type: none"> • The filter cartridge is blocked. Clean or replace the filter cartridge (see para. "4.2.3 Cleaning or replacing the filter cartridge"). • Check that the water balance parameters are correct (see "warnings and warranties" booklet supplied with the equipment). • The pump's pre-filter basket is broken. Replace it. • The pump flow exceeds the filter's nominal flow rate. Adjust the pump speed (on a variable speed pump). For a single speed pump, check that the power is matched to the filter.
The discharge water is dirty.	<ul style="list-style-type: none"> • There is a hole in the filter cartridge. Replace the filter cartridge (see para. "4.2.3 Cleaning or replacing the filter cartridge"). • The filter has not been installed correctly. Check (see para. "2 Installation").
The pressure gauge needle swings constantly.	<ul style="list-style-type: none"> • Air leak in the circuit. Check that all joints are tight. • There is a blockage in the suction and/or discharge pipe. Check the hydraulic circuit. • Check the position of all valves in the hydraulic circuit.

Votre revendeur
Your retailer

Modèle appareil
Appliance model

Numéro de série
Serial number

Trouvez plus d'informations et enregistrez votre produit sur
More informations and register you product on

www.zodiac-poolcare.com

