

FILTROS DE LECHO DE ARENA

Filtros de arena con brazos colectores

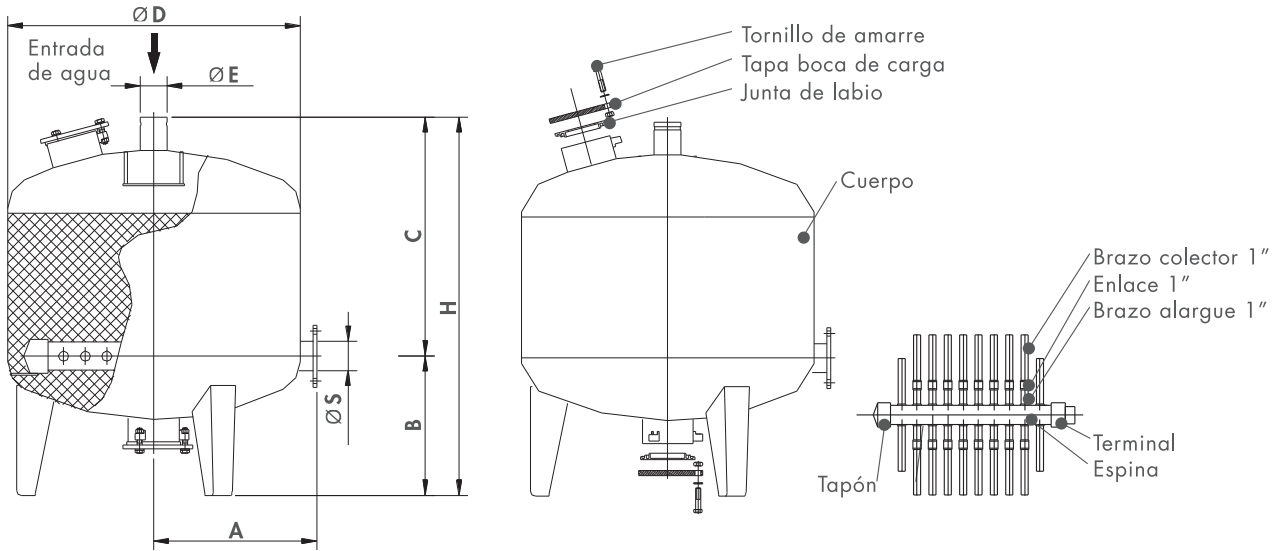

Modelo	ØE	ØS	Dimensiones (mm)					Superficie filtrante (m ²)	Peso vacío (kg.)	Arena (kg.)
			ØD	A	B	C	H			
FAB-500	Rosca H 1" 1/2	Rosca H 1" 1/2	500	285	350	567	917	0,2	46	100
FAB-700	Victaulic 2"	Rosca H 2"	700	380	350	586	936	0,38	63	225
FAB-950	Victaulic 3"	Brida 3"	950	530	450	770	1220	0,71	128	500
FAB-1200	Victaulic 4"	Brida 4"	1200	665	450	815	1265	1,13	189	800

Modelo	Caudales (m ³ /h)		
	Caudal máx.	Nominal	Lavado
FAB-500	15	10	8
FAB-700	25	19	15
FAB-950	45	35	28
FAB-1200	75	55	45

Nota: Otros tamaños consultar.

