

4 WAY FEMALE HOUSING	
APTIV P/N	CODING
33517430	CODING - E
33517235	CODING - F

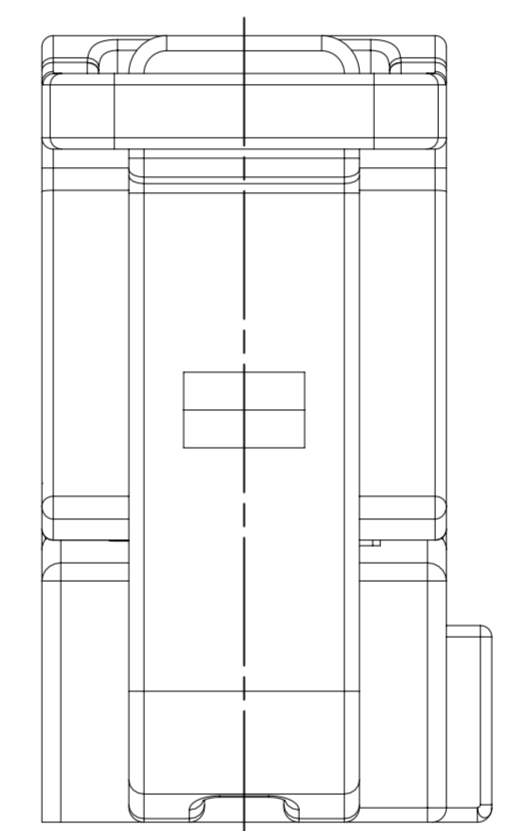

3D VIEW

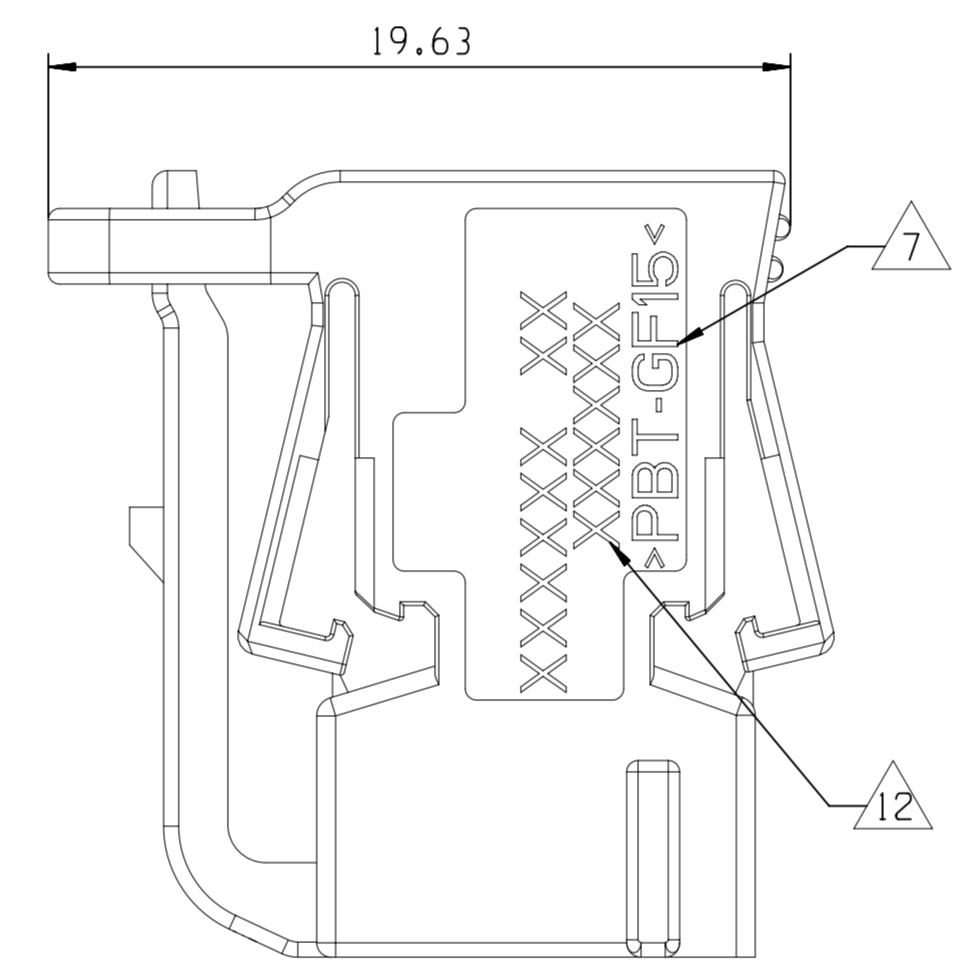
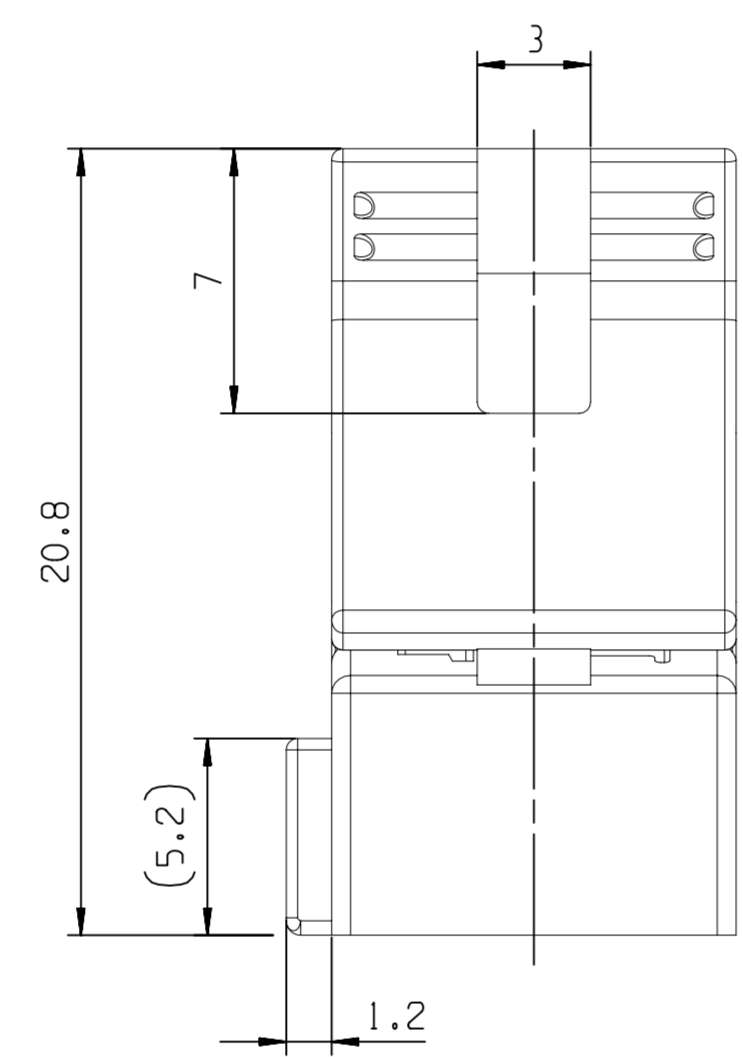
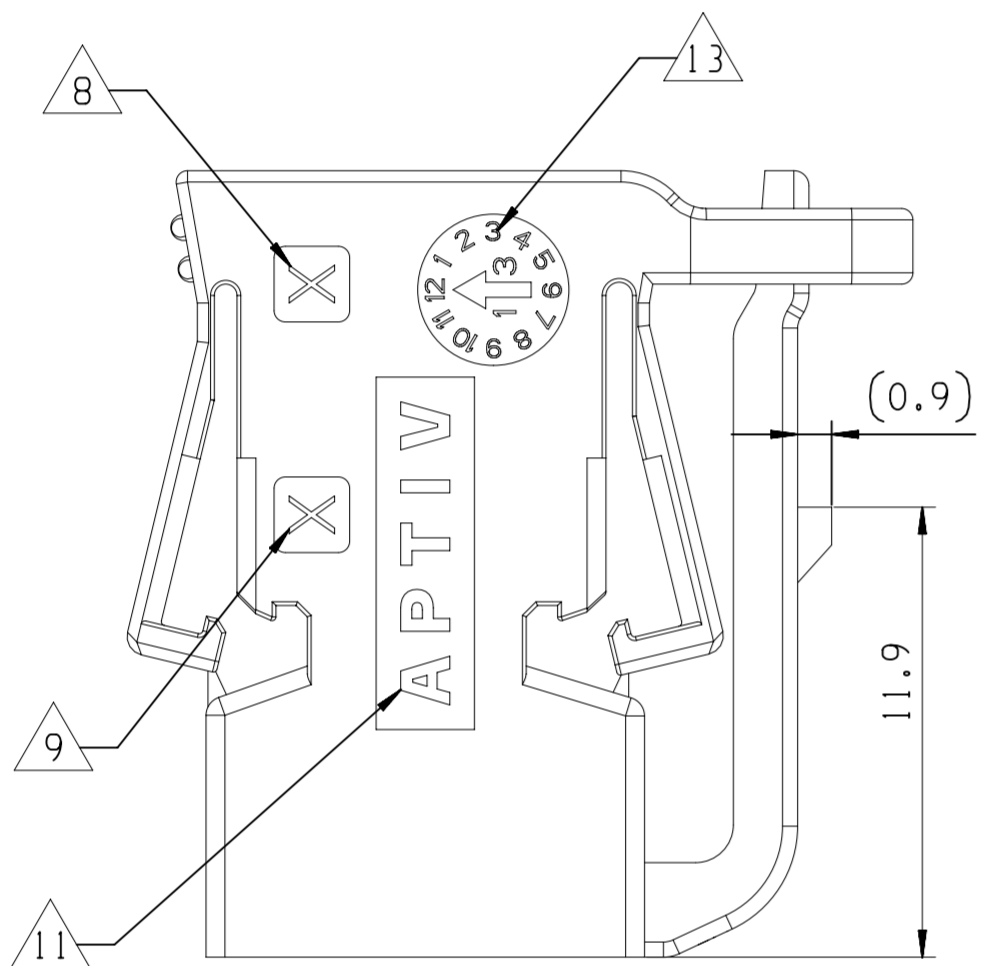
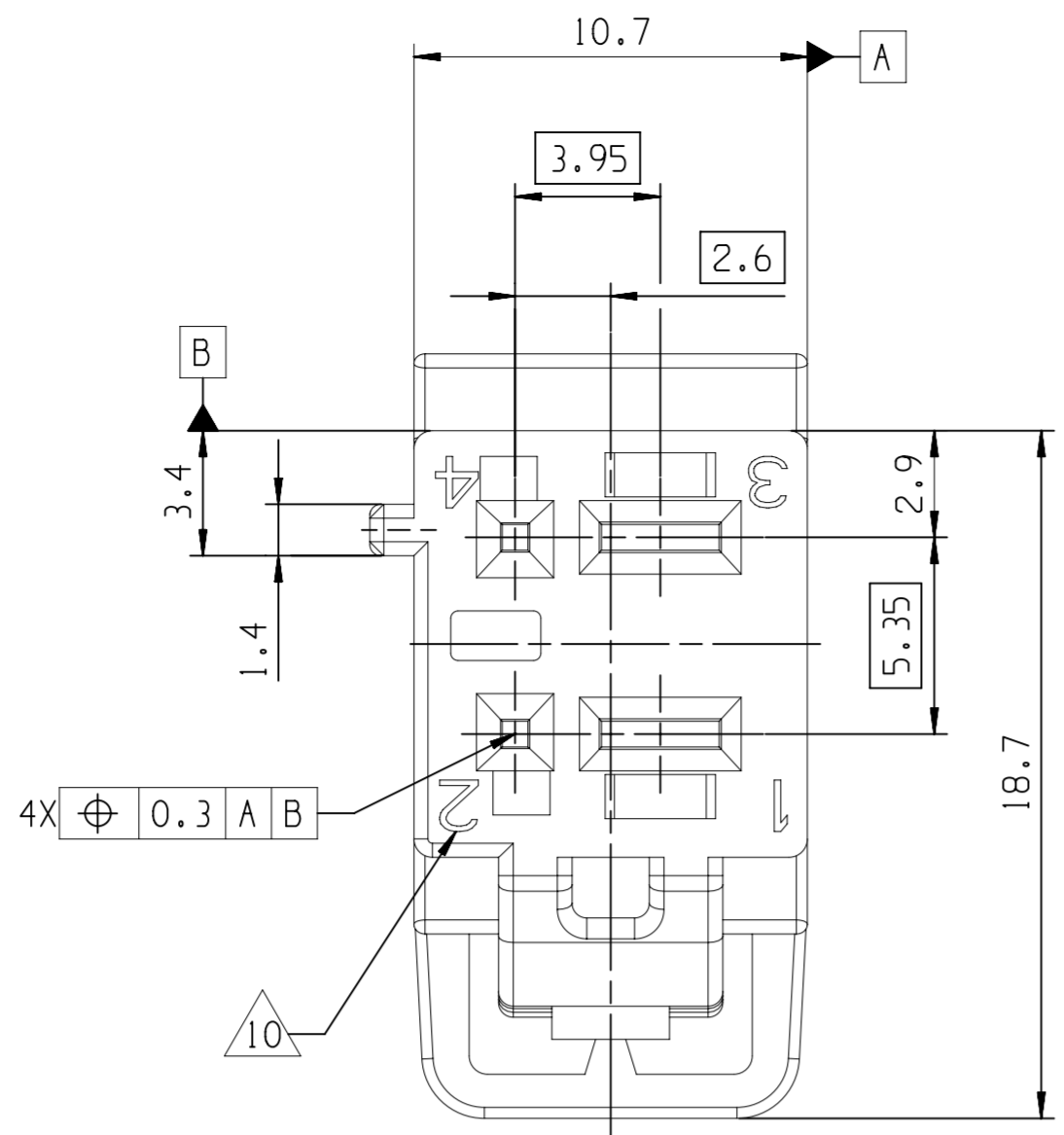
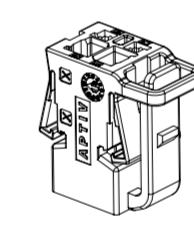

SCALE 1:1

DWG STATUS		ZONE		REVISION HISTORY		AUTH	DR	APVD 1	APVD 2
DATE	STG	REV	N/P/CHG						
24NO21	R	01		INITIAL RELEASE			P.BAL	M.LAG	M.LAG

NOTE	SPECIFICATIONS
1	FEMALE CONNECTOR ACCORDING TO APTIV SPECIFICATION: CAQE XXXX/XXX
2	FEMALE CONNECTOR ACCORDING TO: - TEMPERATURE CLASS T1 - ENGINE VIBRATOR CLASS VI - SEALING CLASS E1
3	USER'S MANUAL: 33517431-CUS72-S01
4	DELIVERY CONNECTOR WEIGHT : SEE TABLE
5	NO WAFER HINGE OR WAFER HINGE BROKEN ALLOWED
6	VISUAL DEFECTS ON NO FUNCTIONAL AREAS ALLOWED
	MATERIAL NAME
	TOOL CAVITY NUMBER
	INDEX REPLACEMENT INSERT
	PART CAVITY NUMBER
	SUPPLIER LOGO
	PART NUMBER
	DATE INSERT

DWG TYP	CUSTOMER PART DRAWING
WEIGHT (GR)	SEE CHART
VOLUME (CM ³)	---
ROUTING	

UNLESS OTHERWISE SPECIFIED	
GENERAL TOLERANCES ACCORDING TO:	SEE CHART
GD&T ACCORDING TO:	ISO 1101

• APTIV •
CONNECTION SYSTEMS
Chennai, India
COPYRIGHT 2021 APTIV. ALL RIGHTS RESERVED.
THIS DRAWING IS THE PROPERTY OF APTIV AND CONTAINS APTIV CONFIDENTIAL INFORMATION. THE REPRODUCTION, DISTRIBUTION AND UTILIZATION OF THIS DOCUMENT OR ITS RELATED CAD MATH DATA, AS WELL AS COMMUNICATION OF ANY CONTENT TO OTHERS, WITHOUT EXPRESS AUTHORIZATION, IS PROHIBITED.

DR	P.BALAJI	DATE	24NO21
APVD1	LAGUETTE MAURICE		24NO21
APVD2	LAGUETTE MAURICE		24NO21
APVD3			
APVD4			
APVD5			

SUBSTANCES OF CONCERN AND RECYCLED CONTENT PER APTIV 10949001

MATERIAL
SEE CHART

DRAWING NAME
4W FEMALE HOUSING
4W FEM. HOUSING CONTROL-UNIT MQS-MPQ

SIZE	A1	SCALE	5:1	FRAME NO	1 OF 1	SHEET NO	1 OF 1	STG	R	REV	01	N/P	
------	----	-------	-----	----------	--------	----------	--------	-----	---	-----	----	-----	--

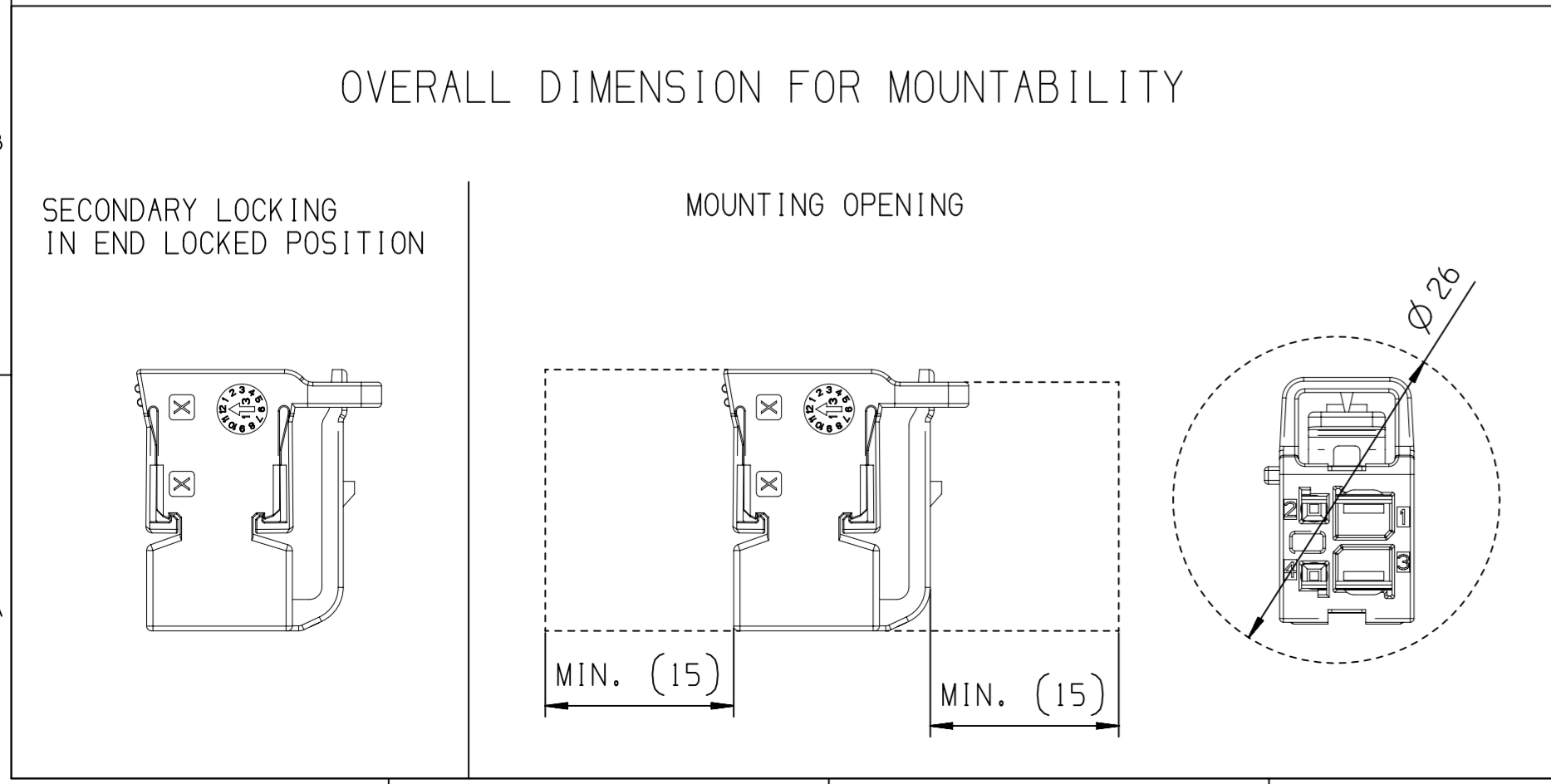

ASSOCIATED PARTS (FOR INFORMATION)			
DESCRIPTION	APTIV P/N	WIRE SECTION	DIAMETER OF WIRE SIZE
MATING PART	33517431-CDE01	-	-
FEMALE TERMINAL MQS 0.63	13580602	0.75mm ²	1.6
FEMALE TERMINAL MPQ 2.8	-	2.5mm ²	2.5

DESCRIPTION	CODE	APTIV PART NUMBER	WEIGHT (kg)	MATERIAL	COLOR
4 WAY FEMALE HOUSING	F	33517235	0.00272	PBT GF15	NUT BROWN
	E	33517430	0.00272	PBT GF15	MAY GREEN

	DIM TO CHECK	DIMENSIONAL RANGE (MM)	CHART	EL
() DIM FOR HELP				
	THEORETIC DIM			

A LINE DRAWN THROUGH A PART NUMBER INDICATES THAT PHYSICAL PARTS ARE NOT AVAILABLE FOR ORDERING.
PART NUMBERS THAT DO NOT HAVE A LINE PRESENT INDICATE THAT PHYSICAL PARTS ARE AVAILABLE FOR ORDERING.
CONTACT APTIV SALES TO ASSURE AVAILABILITY OF PARTS.

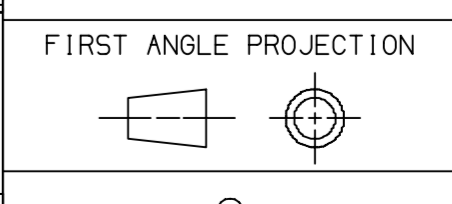
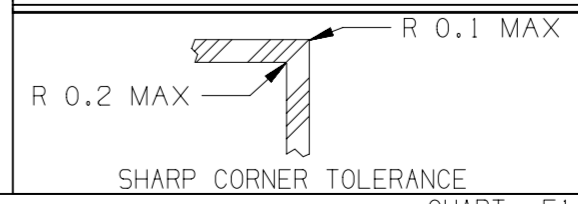

DO NOT SCALE
USE MATH DATA