

NOTES

- ON MAIN VIEW ASSEMBLY 33254221 SHOWN (CODE A)
- DELIVERED CONDITION AS ON MAIN VIEWS - SECONDARY LOCK IN OPEN POSITION
- ASSEMBLY INSTRUCTION NO.:
 35269105-CUS71 - PRELIMINARY ASSEMBLY
 35269105-CUS72 - HARNESS ASSEMBLY
 35269102-CUS73 - CAR ASSEMBLY
- MATING PARTS:
 - 2 WAY 2.8 FEMALE CONNECTOR ASM DWG-NO.: 33253564
 - FIXING SLIDE APTIV DWG-NO.: 33329557 (HT DWG-NO.: 17-1455-001-CS6)
 - BACKSHELL 90 DEG APTIV DWG-NO.: 33365444 (HT DWG-NO.: 17-2274-001-CS6)
 - BACKSHELL 180 DEG APTIV DWG-NO.: 33365244 (HT DWG-NO.: 17-1454-001-CS6)
 - ROTARY BACKSHELL 90 DEG APTIV DWG-NO.: 35024558 (HT DWG-NO.: 18-0195-001-CS6)
 - ROTARY BACKSHELL 180 DEG APTIV DWG-NO.: 35024559 (HT DWG-NO.: 17-0598-001-CS6)
 - PROTECTION CAP APTIV DWG-NO.: 35426243 (HT DWG-NO.: 17-2269-001-CS6)
- MATING TERMINAL SYSTEM:
 - 2.8 TERMINAL DWG-NO.: 13548085
 MAX WIRE CROSS SECTION: 2.5MM²

1 APTIV LOGO
 2 MATERIAL NAME ACCORDING TO VDA 260
 3 DATE INSERT
 4 PART CAVITY NUMBER
 5 MOVING DISTANCE OF SECONDARY LOCK

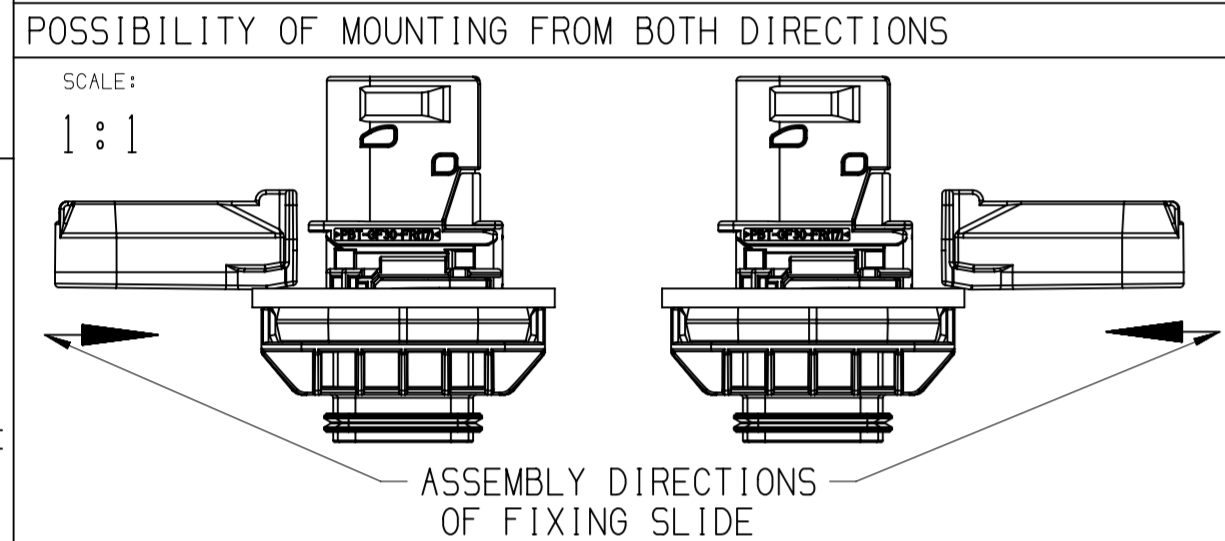

MOUNTING CUT OUT
 VERSION WITH POLARISATION

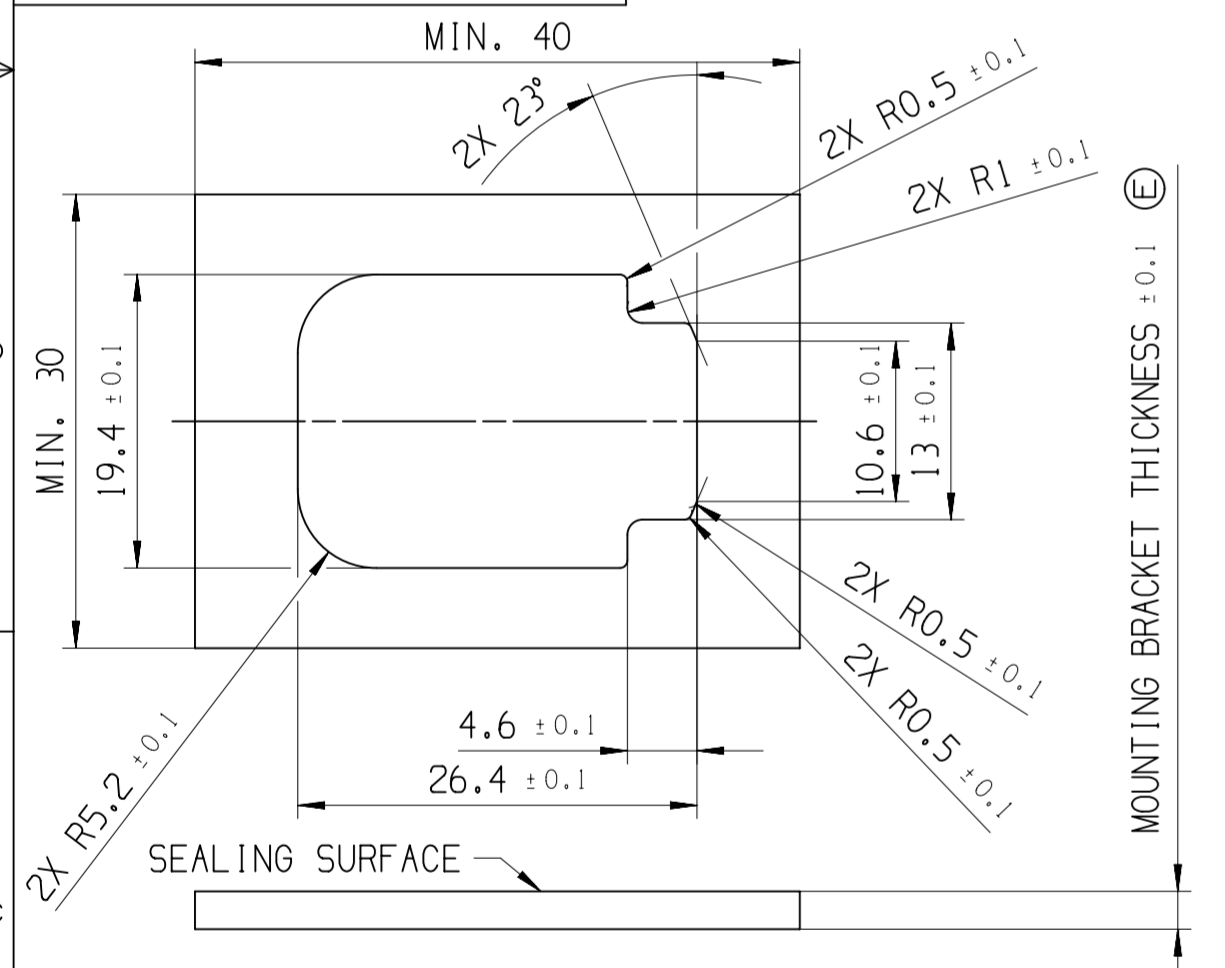

VERSION WITHOUT POLARISATION

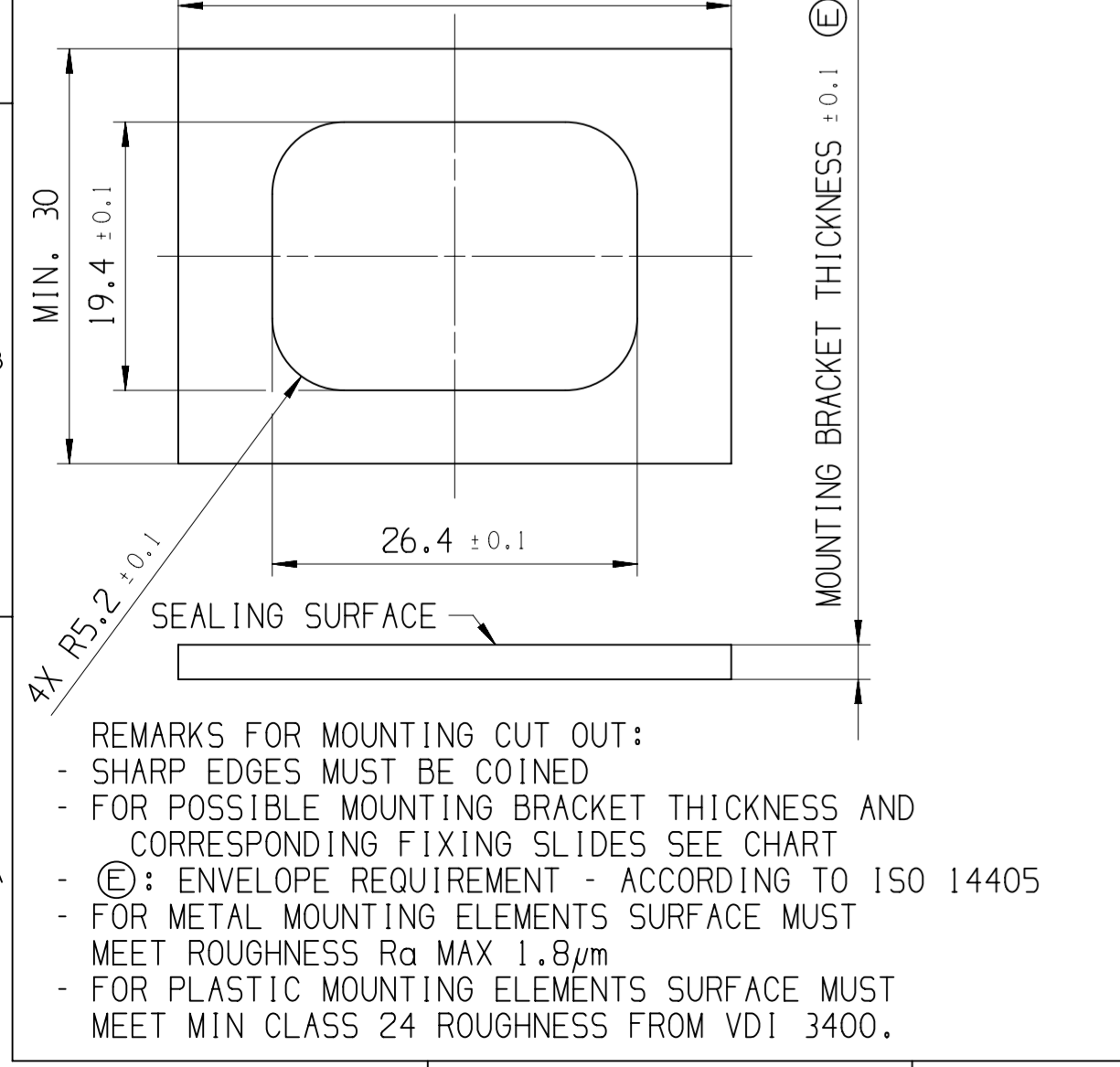

ASSEMBLY-NO.:	PART-REV	CODING	MATERIAL/WEIGHT	1				2		3	4				
				HOUSING PANEL MOUNT				SECONDARY LOCK		SL SEAL	FIXING SEAL				
				BLACK	GRAY	GREEN	BLUE	BLACK	GRAY	GREEN	BLUE	ORANGE	YELLOW	REDDISH-BROWN	REDDISH-BROWN
				33240832	33248986	33248998	33249029	33344625	33344626	33344627	33344634	33249001	33344605	33248990	33248985
33254221	01	CODE A	ALL PARTS VO / 15.5	-	---	---	---	---	---	---	---	---	---	---	
33254220	01	CODE B		-	---	1	---	---	---	---	---	1	---	1	1
33254108	01	CODE C		-	---	---	1	---	---	---	---	1	---	1	1
33254107	01	CODE D		-	---	---	---	1	---	---	---	1	---	1	1
33344850	01	CODE A	ALL PARTS NVO / 15.1	-	---	---	---	1	---	---	---	1	1	1	
33344852	01	CODE B		-	---	---	---	---	1	---	---	---	1	1	
33344868	01	CODE C		-	---	---	---	---	---	1	---	---	1	1	
33344877	01	CODE D		-	---	---	---	---	---	---	1	---	1	1	

SHEET METAL THICKNESS	FIXING SLIDE APTIV/HT PART-NO.:	COLOR
1MM	33366529 / 33366527	NATURAL
1.5MM	33366530 / 33366521	GRAY
2MM	33366531 / 33366520	BLUE
2.5MM	33329558 / 151-02344 / 33344019 / 151-02345	RED
3MM	33329560 / 151-2348 / 33344602 / 151-02349	YELLOW
3.5MM	33329561 / 151-02352 / 33344600 / 151-02353	GRAY
4MM	33366534 / 33366276	GREEN

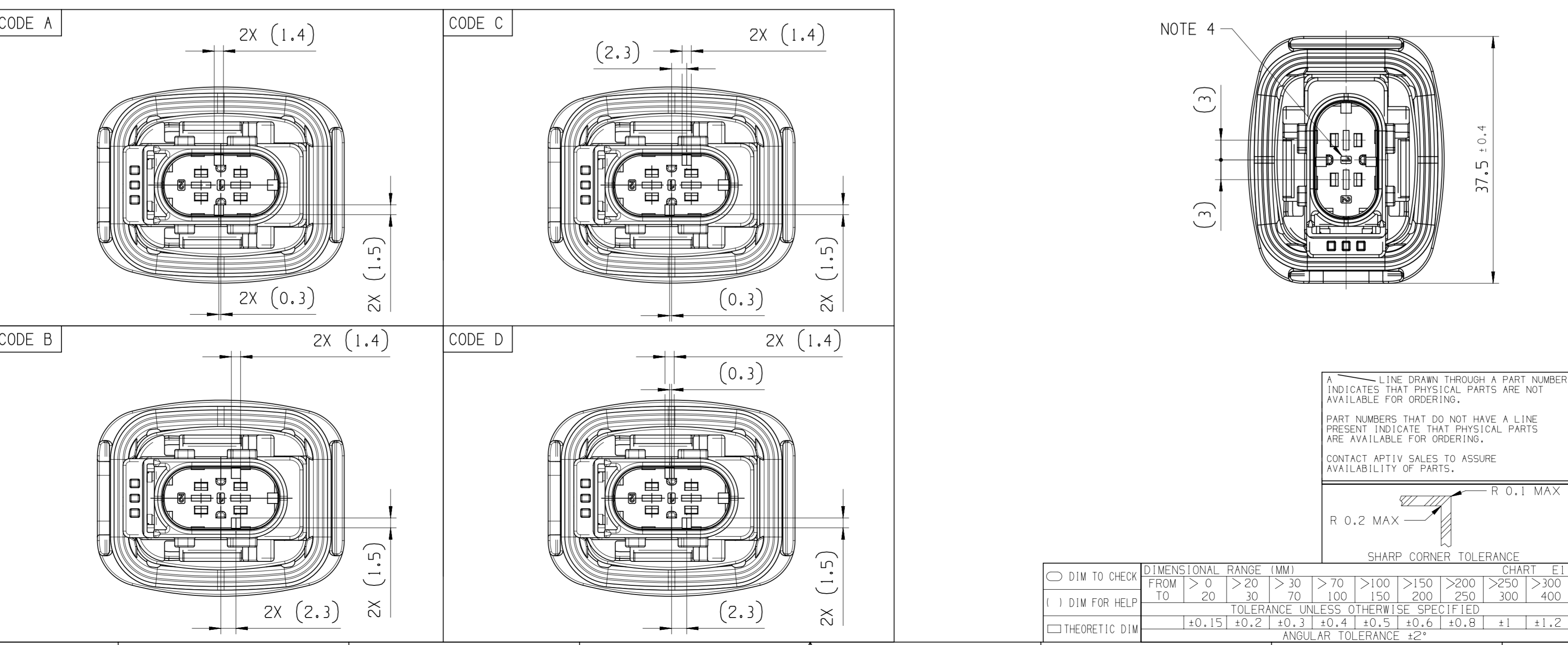
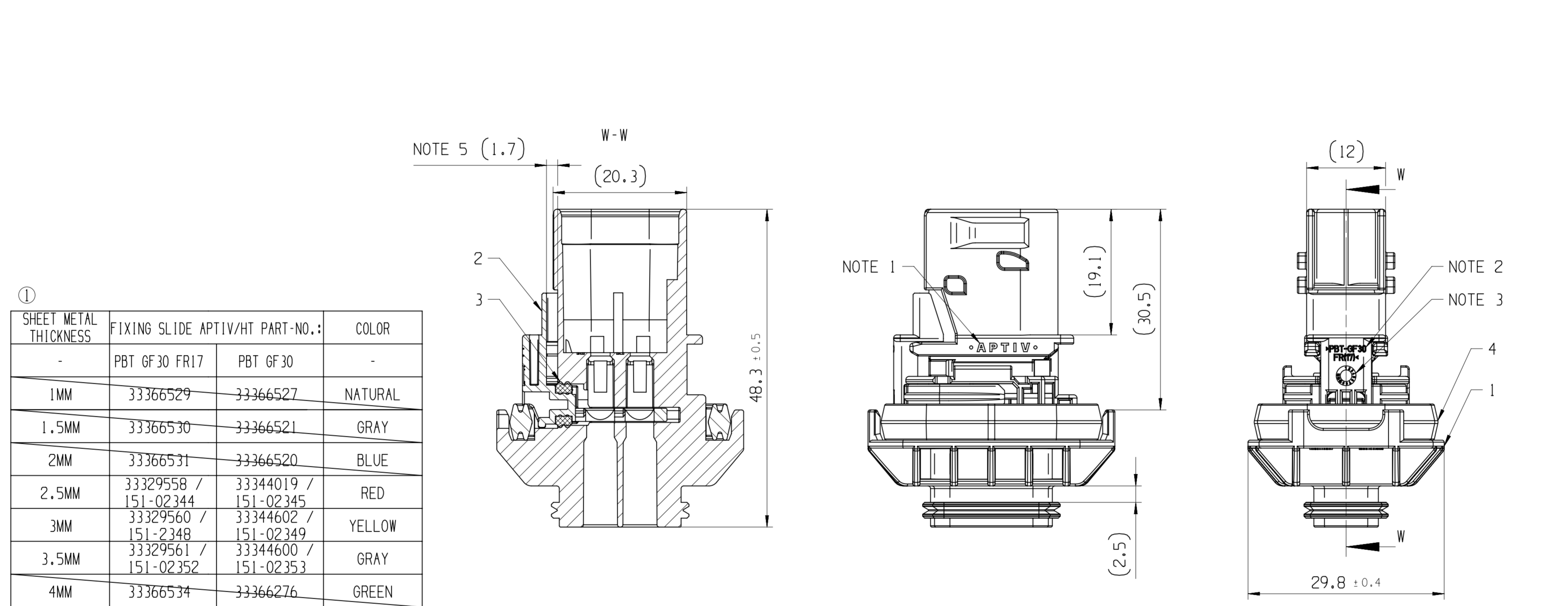

DWG STATUS		ZONE		REVISION HISTORY		AUTH	DR	APVD 1	APVD 2	
DATE	STG	REV	N/P	CHG						
250C18	R	01	AA		G11 E10	INITIAL RELEASE		K.FAR	P.NAJ	M.GRU
300C19	R	01	AB		G10 G10	PROTECTION CAP APTIV DWG-NO.: 35426243 WAS 35274873 PART AVAILABILITY FOR PART NUMBERS 33344850, 33344852, 33344868, 33344877 UPDATED		P.NAJ	M.GRU	
280C20	R	01	AC		G10	HT DWG-NO: 18-0195-001-CS6 WAS 17-0195-001-CS6		P.NAJ	M.GRU	

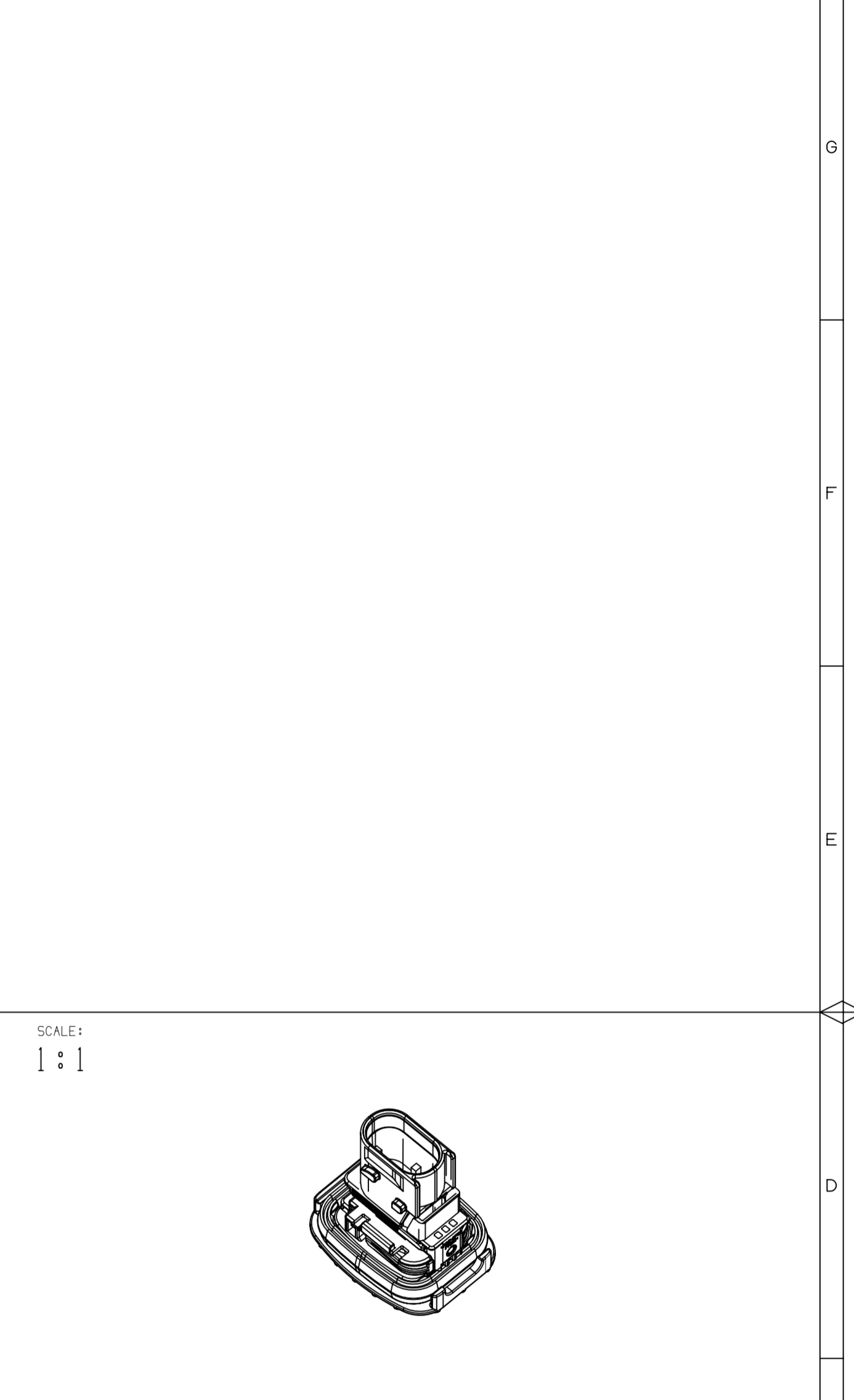

• APTIV •

CONNECTION SYSTEMS
 KRAKOW, POLAND
 COPYRIGHT 2018 APTIV. ALL RIGHTS RESERVED.

THIS DRAWING IS THE PROPERTY OF APTIV AND CONTAINS APTIV CONFIDENTIAL INFORMATION. THE REPRODUCTION, DISTRIBUTION AND UTILIZATION OF THIS DOCUMENT OR ITS RELATED CAD MATH DATA, AS WELL AS COMMUNICATION OF ANY CONTENT TO OTHERS, WITHOUT EXPRESS AUTHORIZATION, IS PROHIBITED.

TEN RYSUNEK JEST WLASNOSCIA APTIV I ZAWIERA POUFNE INFORMACJE POWELANE, ROZPOWISZCZANIE I WYKORZYSTYWANIE TEGO DOKUMENTU LUB ZWIAZANYCH Z NIM DANYCH CAD, JAK ROWNIEZ PRZEKAZYWANIE INNYM JAKIEKOLWIEK ICH ZAWARTOSCI, BEZ NADANA WYRAZNYCH UPRAWNIEN, JEST ZABRONIONE.

	DATE
DR	K.FARON
APVD1	P.NAJDUCH
APVD2	M.GRUDZEWSKI
APVD3	
APVD4	
APVD5	

SUBSTANCES OF CONCERN AND RECYCLED CONTENT PER APTIV 10949001 SUBSTANCJE NIEBEZPIECZNE I POWTORNIE PRZETWORZONE OKRESLA APTIV 10949001

MATERIAL: SEE CHART

DRAWING NAME: 2 WAY 2.8 PANEL MOUNT CTCS MALE ASSEMBLY

DRAWING NUMBER: 33254106

SIZE	SCALE	FRAME NO	SHEET NO	STG	REV	N/P	AC
A1	2:1	1 OF 1	1 OF 1	R	01		