

SYMBOL DEFINITION		MISSING SYMBOLS	
A DIMENSION WITHOUT AN INSPECTION REPORT SYMBOL ( ) DOES NOT REQUIRE INSPECTION. IT MAY BE CONTROLLED ON THE INDIVIDUAL COMPONENT DRAWING.	TOTAL NO OF INSPECTIONS REQUIRED	2	4 10 12
	LAST NO. USED		14

DWG STATUS					ZONE	REVISION HISTORY	AUTH	DR	APVD 1	APVD 2
DATE	STG	REV	N/P	CHG						
02MY11	R	01	-	-		ALL PARTS - CREATED PART DRAWING	414129	LLJ	LLJ	HL
01FE12	R	02	-	-		13884348 - DIM "A" WAS 1.4, DIM "B" WAS 2.6 AND ADDED 0.75 MM <sup>2</sup> TO CABLE SIZE. 13884349 - DIM "A" WAS 1.73 AND REMOVED 0.8 MM <sup>2</sup> FROM CABLE SIZE.	416933	LLJ	LLJ	HL
02AP12	R	03	-	-		ALL PARTS - ADDED VENDOR PART NUMBER.	417671	LLJ	LLJ	HL
14MY12	R	04	-	-		ALL PARTS - ADDED "HARNESS MANUFACTURER", AND "SOLDERED CRIMPS" NOTES.	418163	LLJ	LLJ	HL
12NO12	R	05	-	-		ALL PARTS - ADDED GROOVE AND DIM 13-14.	420361	LLJ	LLJ	BM
24AP14	R	06	-	-		ALL PARTS - "PSD" WAS #9 AND UPDATED "VENDOR PART NUMBER"; 13884349 - UPDATED PART AVAILABILITY	426201	ORA	JAA	BM
02SE21	R	07	-	-		ALL PARTS - UPDATED "PACKAGING" NOTE	555141	GDH	JAA	MF

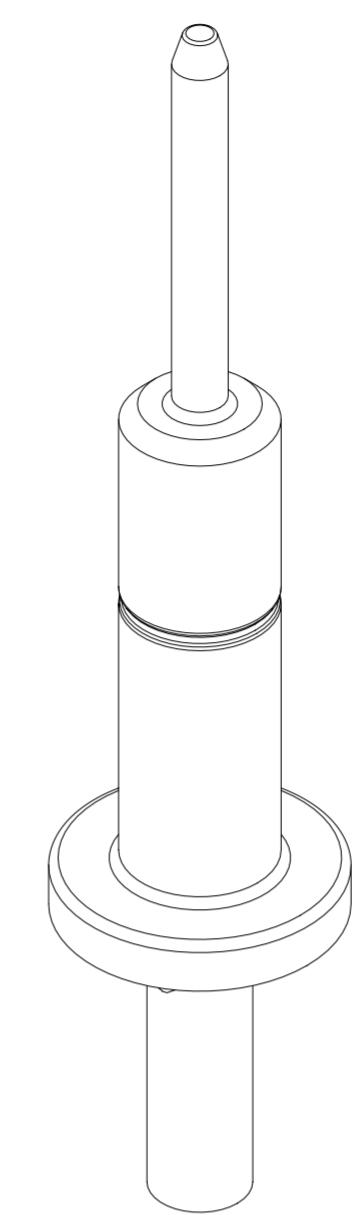
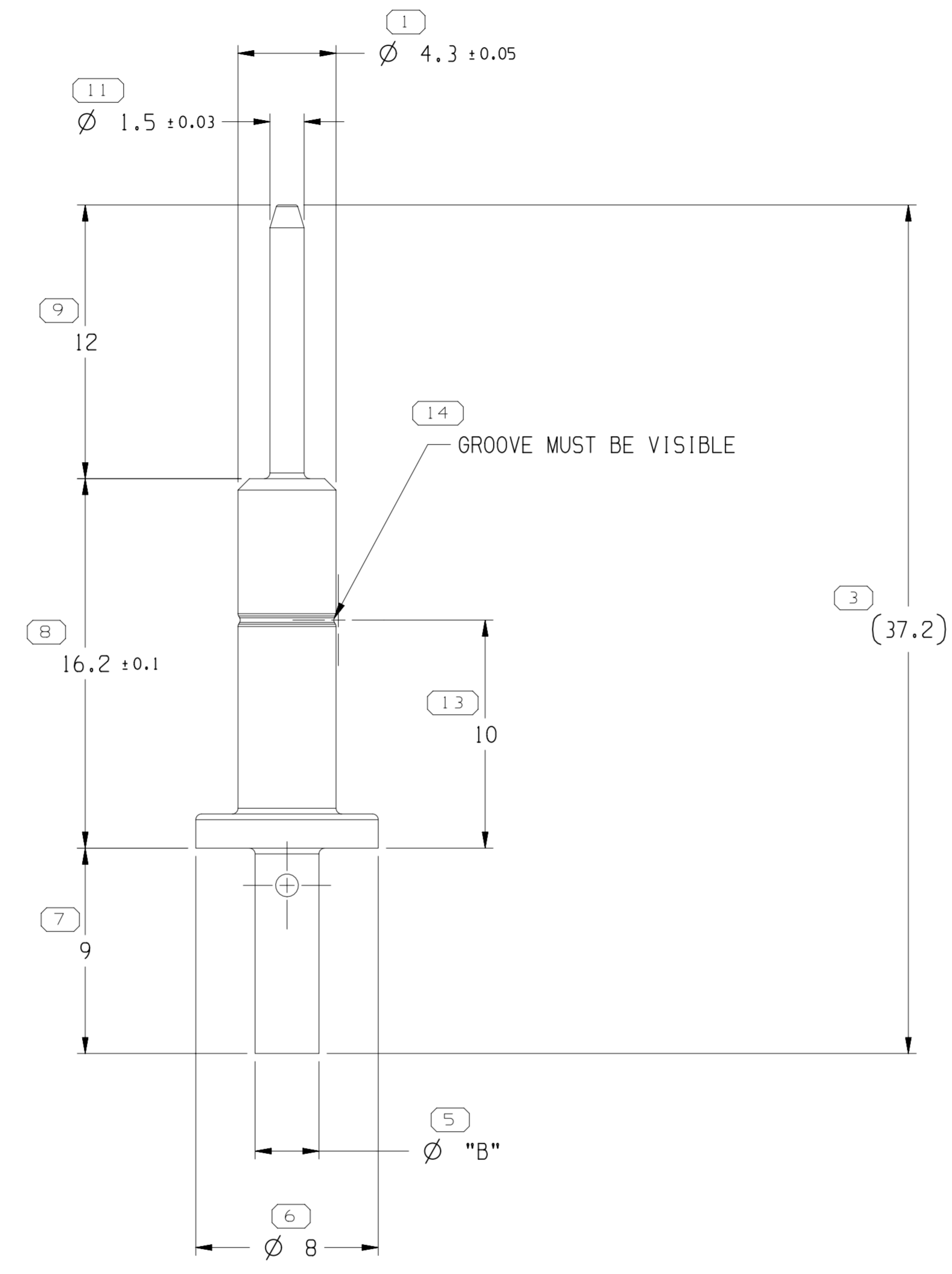

- NOTES
- UNLESS OTHERWISE SPECIFIED AND/OR INDICATED:  
DIMENSIONS ARE TO FACE OF VIEW SHOWN AND AUTOMATICALLY ROUNDED BY COMPUTER FOR INSPECTION (SEE MATH MODEL FOR PRECISE DIMENSIONS). FOR ALL OTHER DIMENSIONS NOT SHOWN BUT REQUIRED FOR TOOL BUILD, SEE MATH MODEL FOR PRECISE TOOL PATH DATA.
  - PINS MUST BE FREE OF BURRS, SHARP EDGES, OIL, GREASE OR OTHER CONTAMINANTS.
  - INDIVIDUALIZED TRAY PACKAGING TO BE USED - NO BULK PACKAGING. PACKAGING TO BE SEALED.
  - HARNESS MANUFACTURER IS RESPONSIBLE FOR VALIDATING THE CRIMP AS APPLIED ON CABLE TO CUSTOMER APPLICATION REQUIREMENTS.
  - SOLDERED CRIMPS ARE RECOMMENDED FOR THE EV CHARGING APPLICATION.

PART NO	REV	N/P	VENDOR PART NUMBER	MAT'L SPEC	CONTACT PLATING	Ø "B"	CABLE SIZE
13884348	03	AB	181 530 000 349 000	BRASS 1/2 HARD	SILVER	2.5	18 GA. (0.8MM <sup>2</sup> - 0.75 MM <sup>2</sup> )
13884349	03	AB	181 531 000 349 000	BRASS 1/2 HARD	SILVER	2.8	16 GA. (1 MM <sup>2</sup> )

(11) PROCESS SENSITIVE DIMENSION	
DIMENSIONS ENCLOSED IN ( ) INDICATE REFERENCE DIMENSIONS AND NO TOLERANCE LIMITS ARE ESTABLISHED	
DIMENSIONAL RANGE (MM) CHART D	
FROM 0 TO 12	> 12
TOLERANCE UNLESS OTHERWISE SPECIFIED	
+0.1	+0.2
ANGULAR TOLERANCE	+2°

A LINE DRAWN THROUGH A PART NUMBER INDICATES THAT PHYSICAL PARTS ARE NOT AVAILABLE FOR ORDERING.

PART NUMBERS THAT DO NOT HAVE A LINE PRESENT INDICATE THAT PHYSICAL PARTS ARE AVAILABLE FOR ORDERING.

CONTACT APTIV SALES TO ASSURE AVAILABILITY OF PARTS.

DWG TYPE: PART DRAWING

STYLE: [Symbol]

VOLUME (CM<sup>3</sup>): [Symbol] D

DISTR CODE: [Symbol]

UNLESS OTHERWISE SPECIFIED THIS DOCUMENT IS IN ACCORDANCE WITH ASME Y14.5M-1994 AS AMENDED BY THE GM GLOBAL DIMENSIONING AND TOLERANCING ADDENDUM-2001. SEPARATE PATTERNS OF FEATURES MAY BE GAGED SEPARATELY REGARDLESS OF DATUM REFERENCES.

ALL DIMENSIONS ARE IN MILLIMETERS

THIRD ANGLE PROJECTION [Symbol]

DO NOT SCALE [Symbol]

USE MATH DATA [Symbol]

NX [Symbol]

**• APTIV •**

CONNECTION SYSTEMS

WARREN, OH

COPYRIGHT 2011 APTIV. ALL RIGHTS RESERVED.

THIS DRAWING IS THE PROPERTY OF APTIV AND CONTAINS APTIV CONFIDENTIAL INFORMATION. THE REPRODUCTION, DISTRIBUTION AND UTILIZATION OF THIS DOCUMENT OR ITS RELATED CAD MATH DATA, AS WELL AS COMMUNICATION OF ANY CONTENT TO OTHERS, WITHOUT EXPRESS AUTHORIZATION, IS PROHIBITED.

DR	DATE
APVD1 L. JONES	02MY11
APVD2 L. JONES	02MY11
APVD3 HOI LUI	02MY11
APVD4	
APVD5	

SUBSTANCES OF CONCERN AND RECYCLED CONTENT PER APTIV 10949001

MATERIAL SEE CHART

DRAWING NAME: TAXI TERM M SLV/PIN AG

DRAWING NUMBER: 13884346

SIZE A1	SCALE 5:1	FRAME NO 1 OF 1	SHEET NO 1 OF 1	STG R	REV 07	N/P -
---------	-----------	-----------------	-----------------	-------	--------	-------