

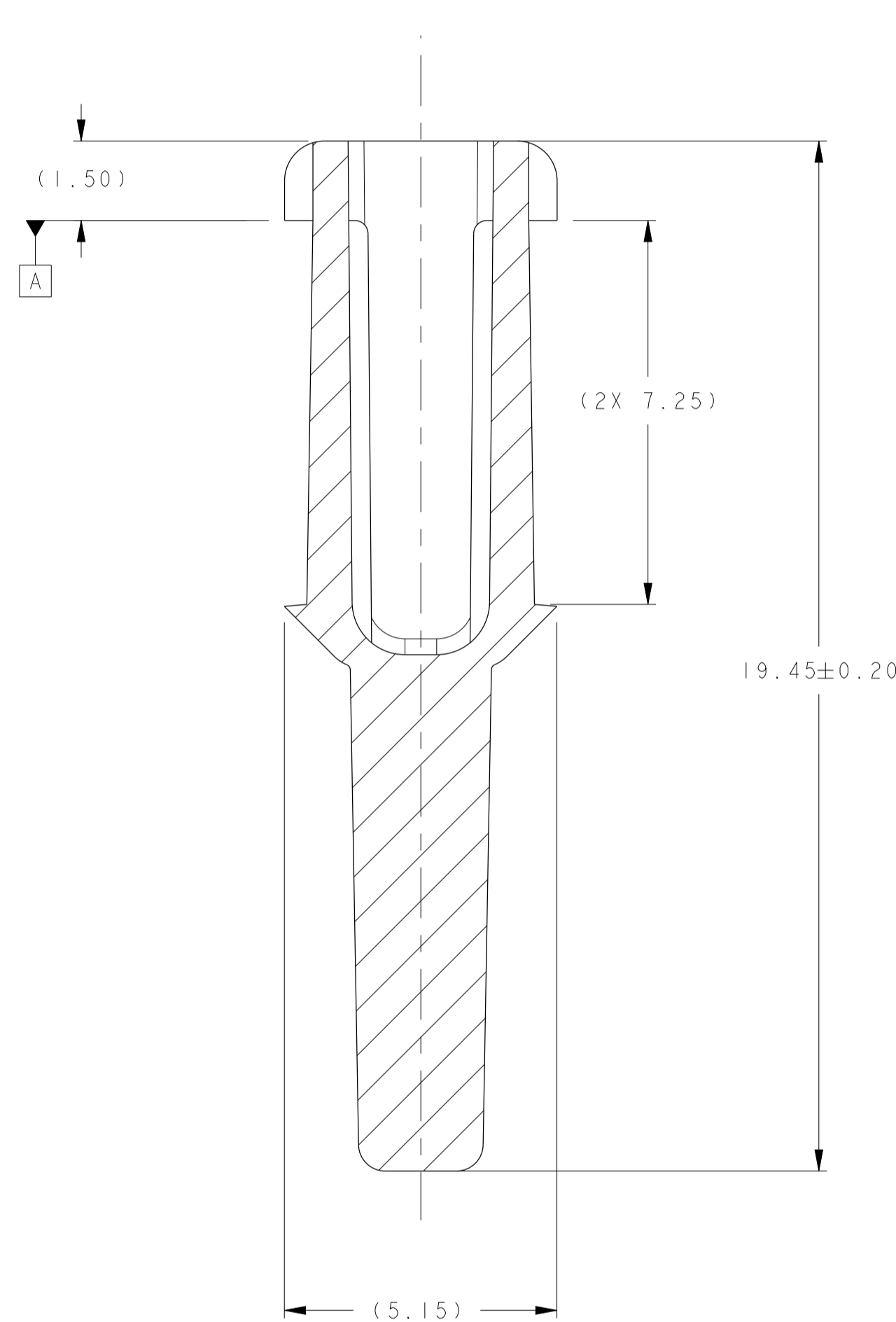

SCALE 1:1

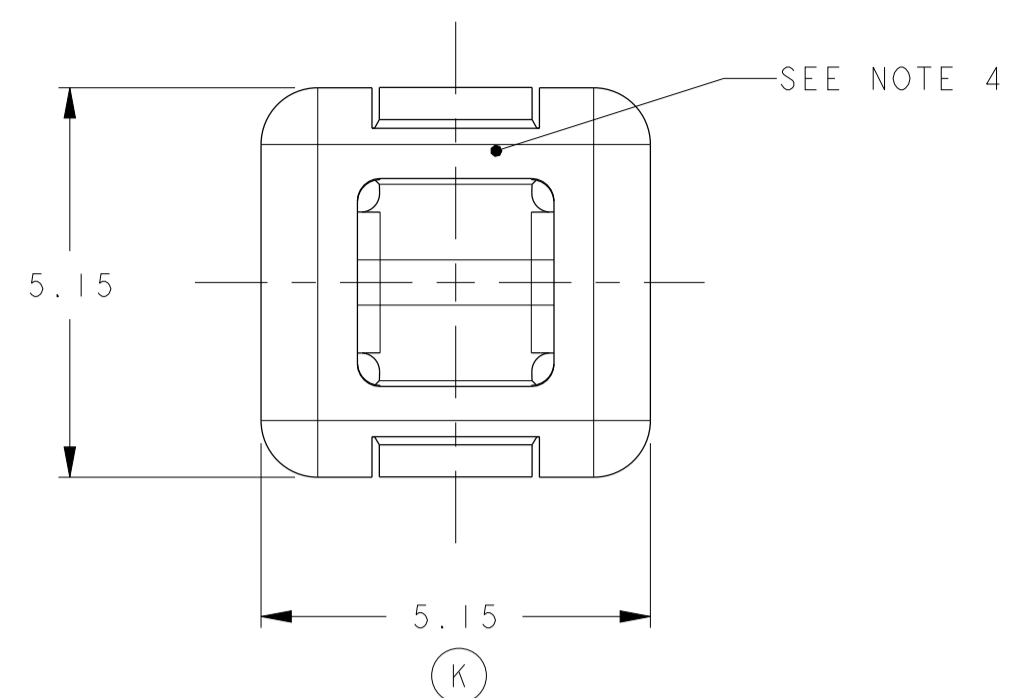

SECTION A - A

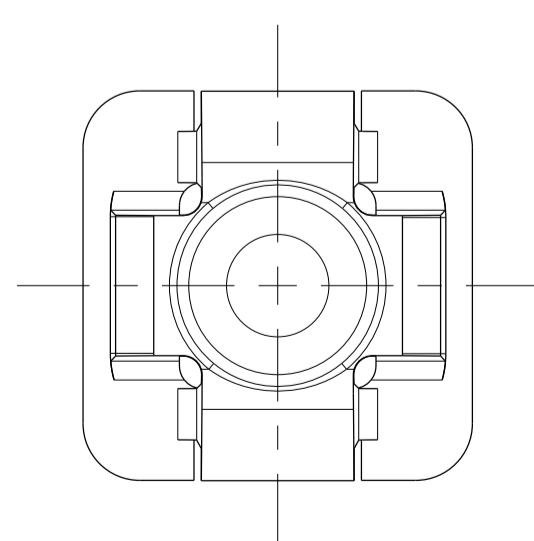
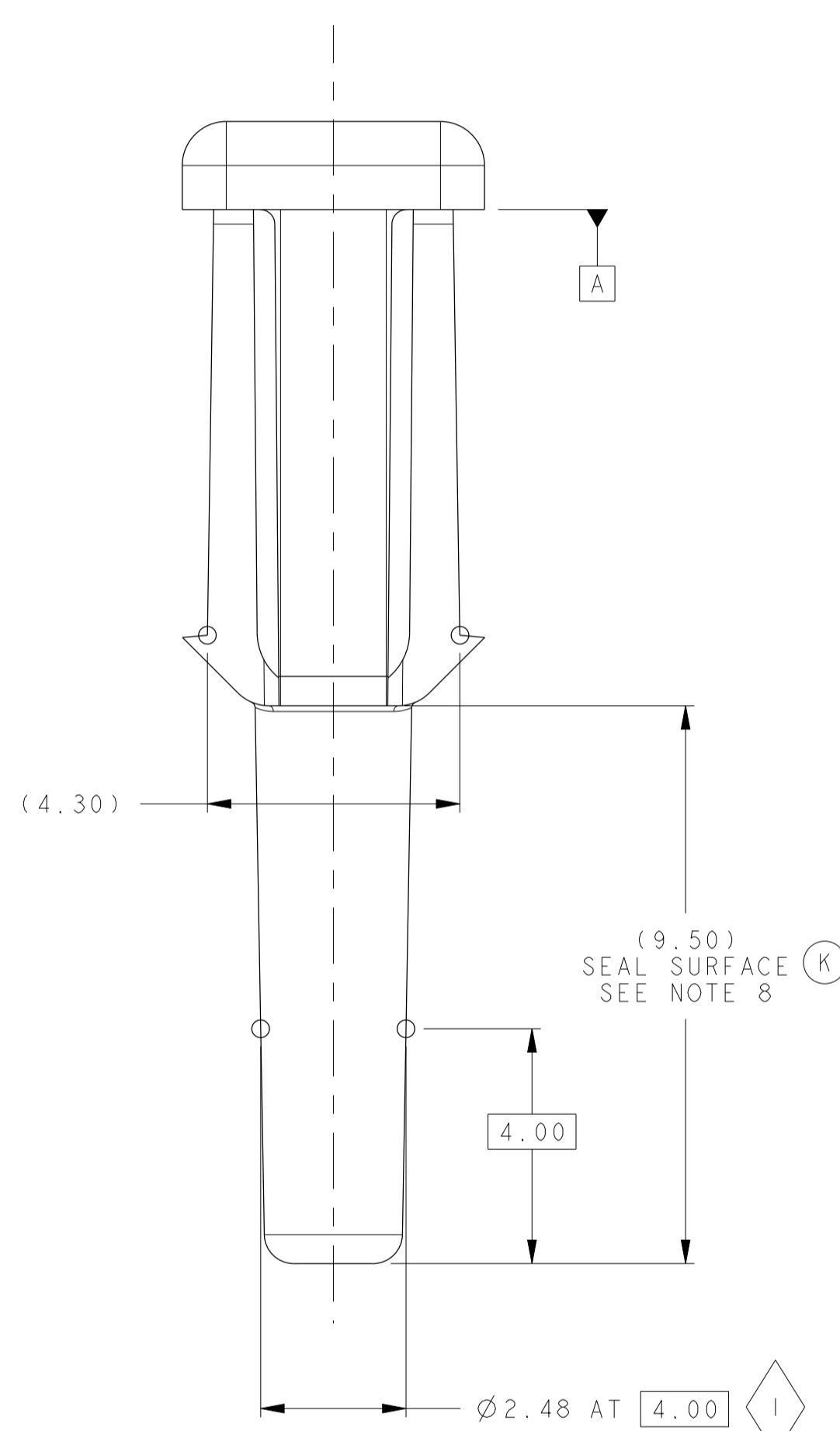
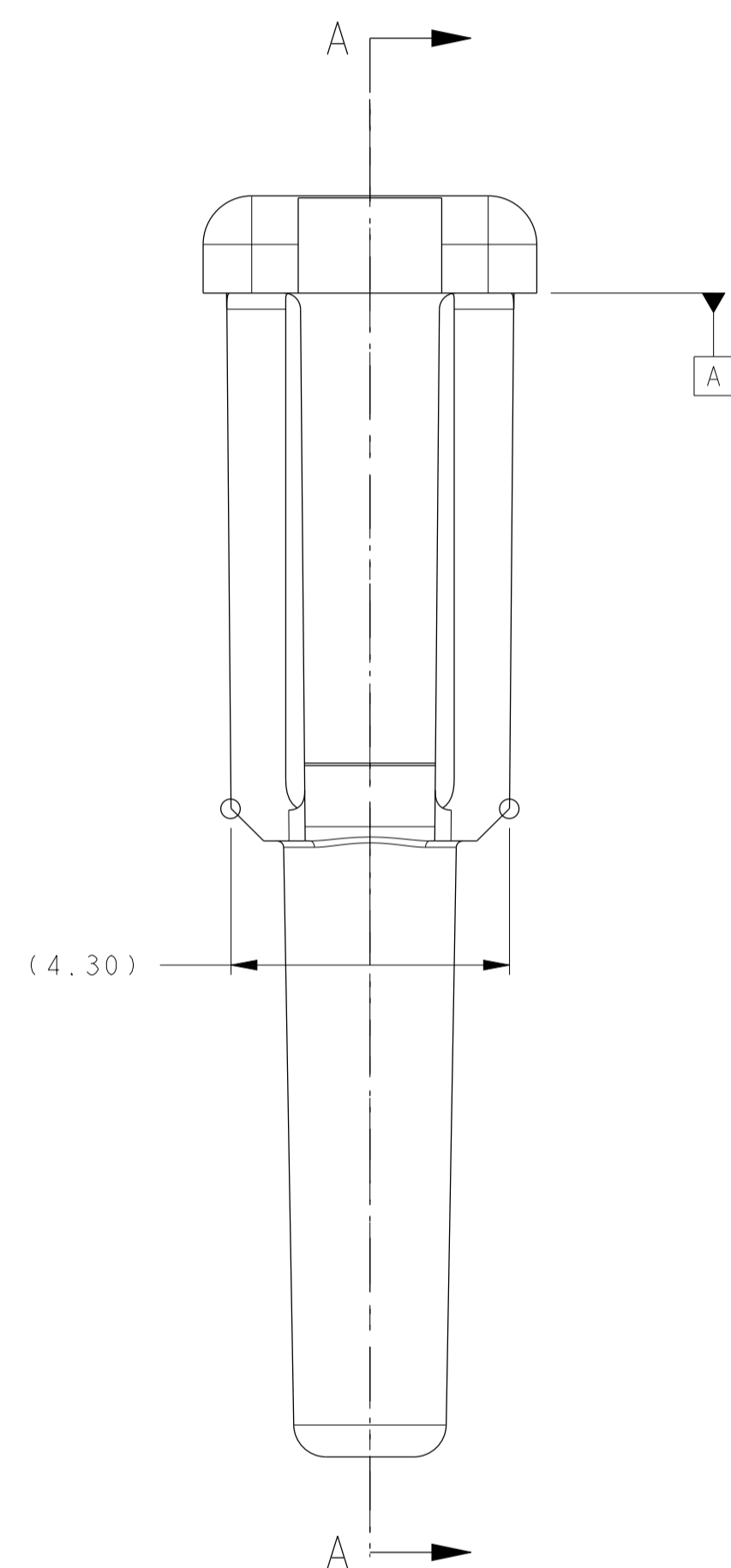

NOTES:

1. UNLESS OTHERWISE SPECIFIED:

TOLERANCE ON:
 1 PLACE DIMENSIONS: ±0.25
 2 PLACE DIMENSIONS: ±0.10
 ANGULAR DIMENSIONS: ±3°

2. PART TO BE MOLDED FREE FROM FLASH, VOIDS, STRESSES, IMPERFECTIONS, AND TOOL MARKS, THAT AFFECT FUNCTION, OR HANDLING OF THE PART
3. ALL EJECTOR MARKS TO BE RAISED + 0.25MM OR RECESSED -0.25MM BELOW THE SURFACE OF THE PART
4. SOURCE ID, MOLD ID, CAVITY ID AND RECYCLE CODE TO BE SHOWN LEGIBLY WITH RAISED OR DEPRESSED CHARACTERS TO BE (1.0 HIGH X 0.30 WIDE) MINIMUM
5. MOLD VENDOR TO SUBMIT FOR ENGINEERING APPROVAL, LOCATION AND TYPES OF PULLER RINGS, GATING, PARTING LINES AND EJECTION MARKS PRIOR TO CONSTRUCTION OF TOOLING.
6. MATERIAL: PER MS-DB41 NYLON PA66 GF35
 BASF ULTRAMID A3EG7 OR EQUIVALENT, 100% REGRIND ALLOWED
 COLOR: NATURAL
 RECYCLE CODE: >PA66 GF35<
7. PART VOLUME: 127.098 MM³
8. NO PARTING LINE OR TOOLING MARKS PERMISSIBLE ON SEALING SURFACE
9. INDICATES QUALITY ASSURANCE REQUIREMENTS
 SPC DATA REQUIRED: I
10. INDICATES IN PROCESS INSPECTION FOR MANUFACTURING, DIMENSIONS OR SPECIFICATION IS REQUIRED.
11. MUST CONFORM TO USCAR 2, REV 4

13-01386	ALL	ECO 424955 - REVISED & REDRAW IN PDS, ADDED DELPHI P/N, MATERIAL SPECIFICATION AND REV LEVEL FOR MVL PART TITLE REVISED WAS SEAL PLUG APEX 150	
ECN-NO.	ZONE	CHANGE DESCRIPTION	
PROJECT SPEC:	PACKAGING SPEC:	APPLICATION SPEC:	COPYRIGHT DELPHI CORPORATION AND/OR ITS AFFILIATES. ALL RIGHTS RESERVED. REVISED THIS DRAWING IS THE PROPERTY OF DELPHI CORPORATION AND CONTAINS DELPHI CONFIDENTIAL INFORMATION. THE REPRODUCTION, DISTRIBUTION AND UTILIZATION OF THIS DOCUMENT OR ITS RELATED CAD DATA, AS WELL AS COMMUNICATION OF ANY CONTENT TO OTHERS, WITHOUT EXPRESS AUTHORIZATION, IS PROHIBITED.
APEX 150			
TOLERANCES	SEE NOTES	MATERIAL:	SEE NOTES
CONTRACT NO.:	APEX 150 HYBRID SYS	COLOR:	NATURAL
DO NOT MEASURE DRAWING		TOOL NO.:	M425-FEM/CUST
ECO Loc.:	C446	AN	
CREATED BY:	2008-10-18	TITLE	SEAL PLUG APEX 150
MODIFIED BY:	2015-10-13	PROJECT	28 FEMALE CAVITY
CHECKED BY:	2014-09-08	STATE	K53023-CUST
APPROVED BY:	2014-09-08	PART NUMBER	54240002
FILE NAME	K53023-CUST	DOCUMENT UNDER PDS CONTROL. NO MODIFICATION ALLOWED OUTSIDE	

54240002	B	13770939	01	M5600101
MVL	PCL	DELPHI	REV	SPECIFICATION
PART NUMBERS		MATERIAL		