

ASSY SHELL+LEVER+HOUSING

APTIV PART NUMBER CODEING

13553389 CODE A

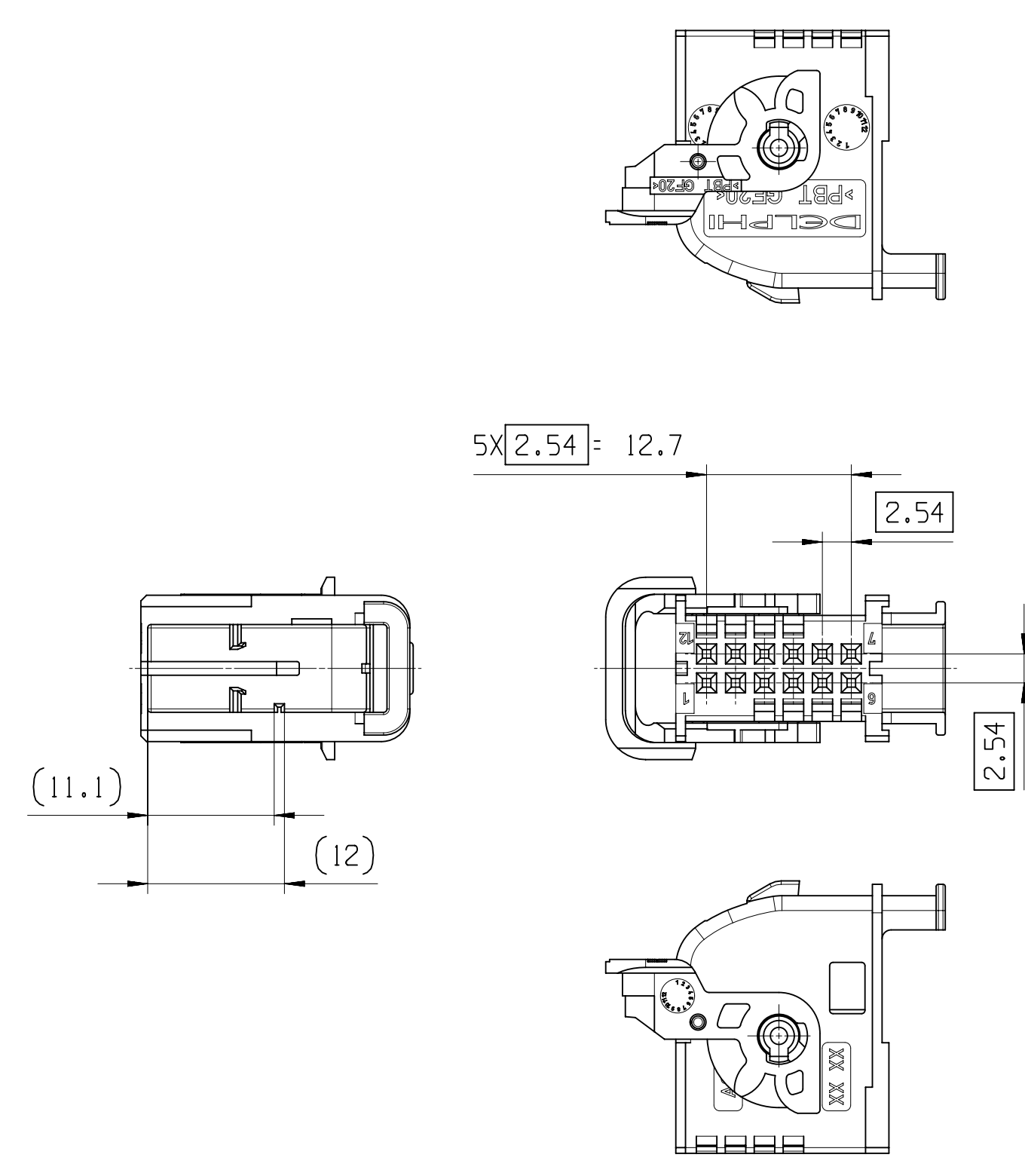

13553390 CODE B

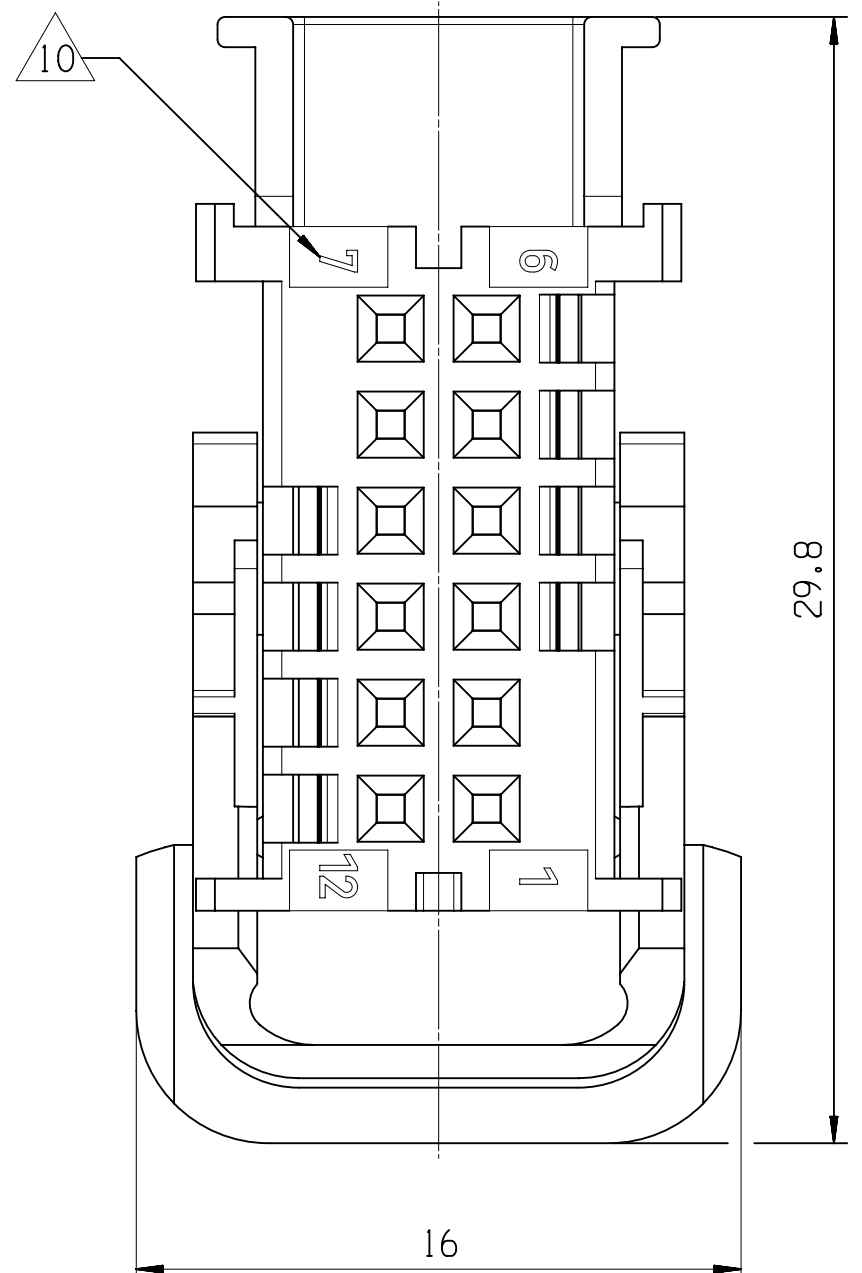
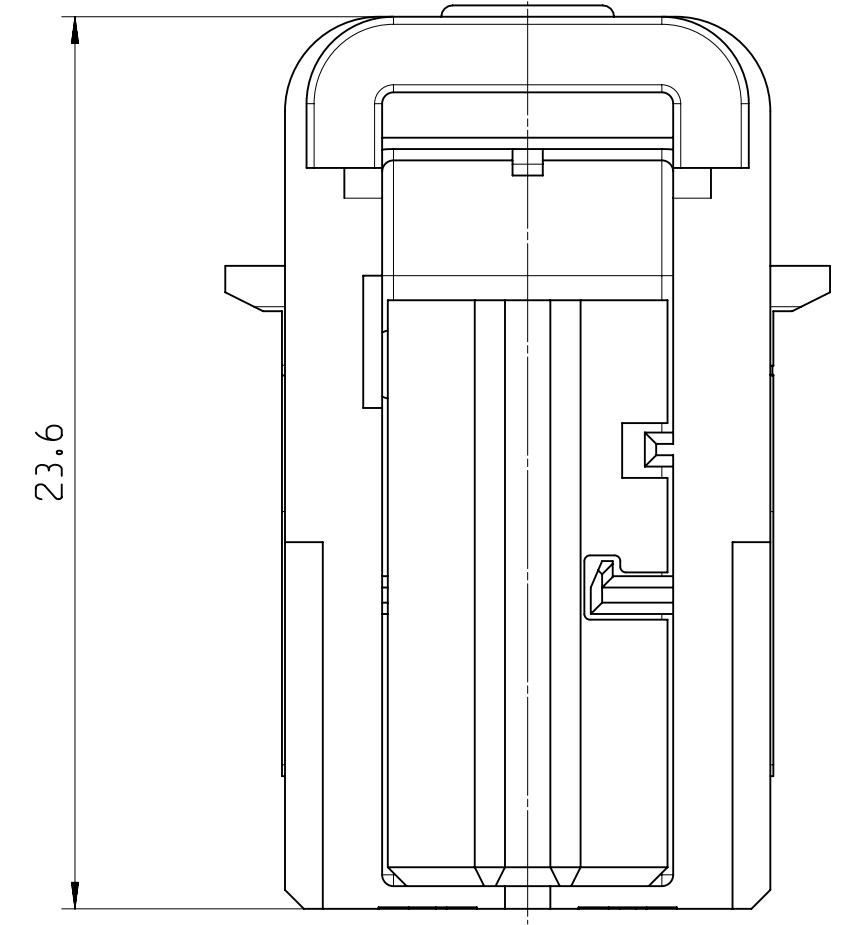
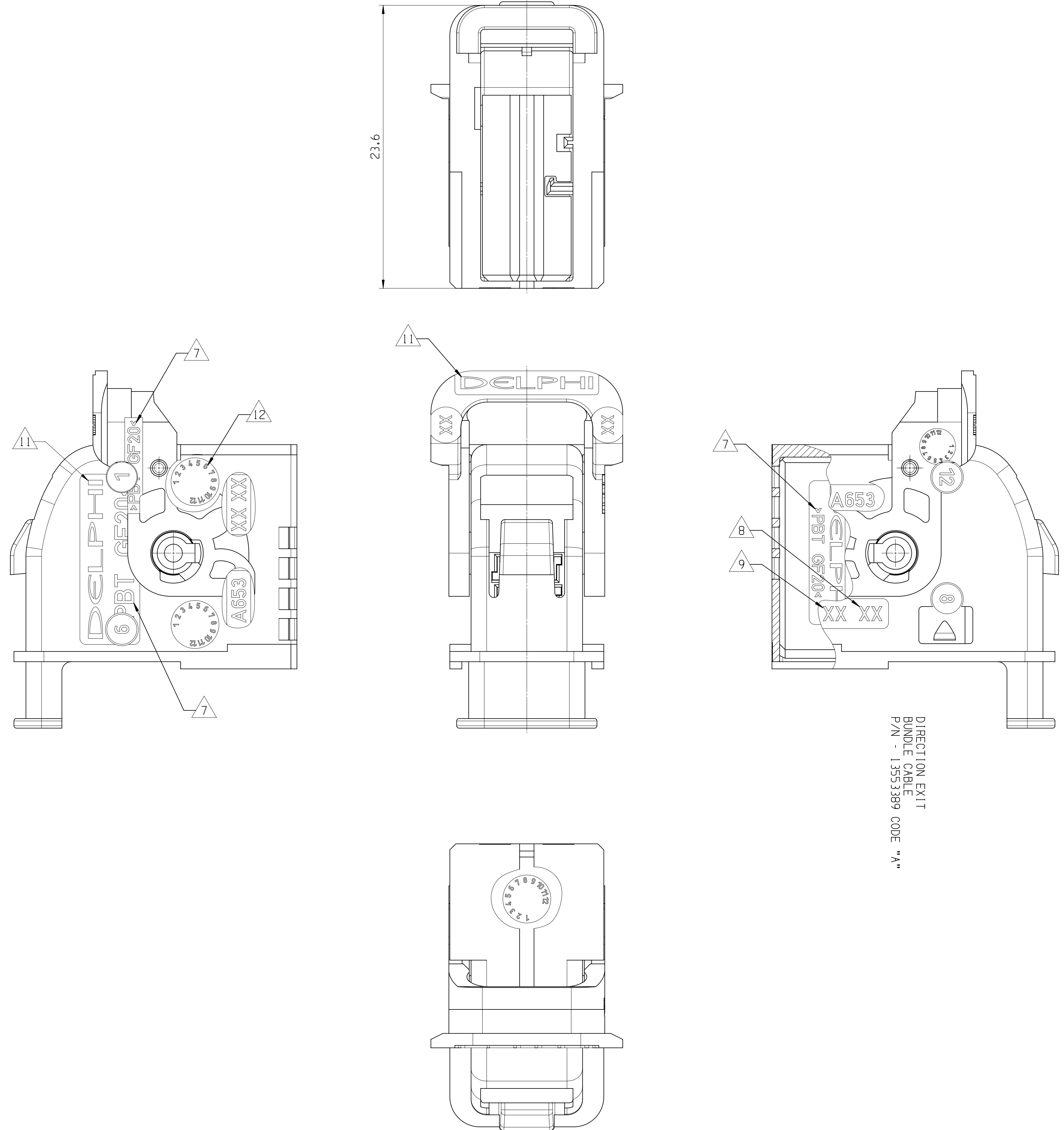
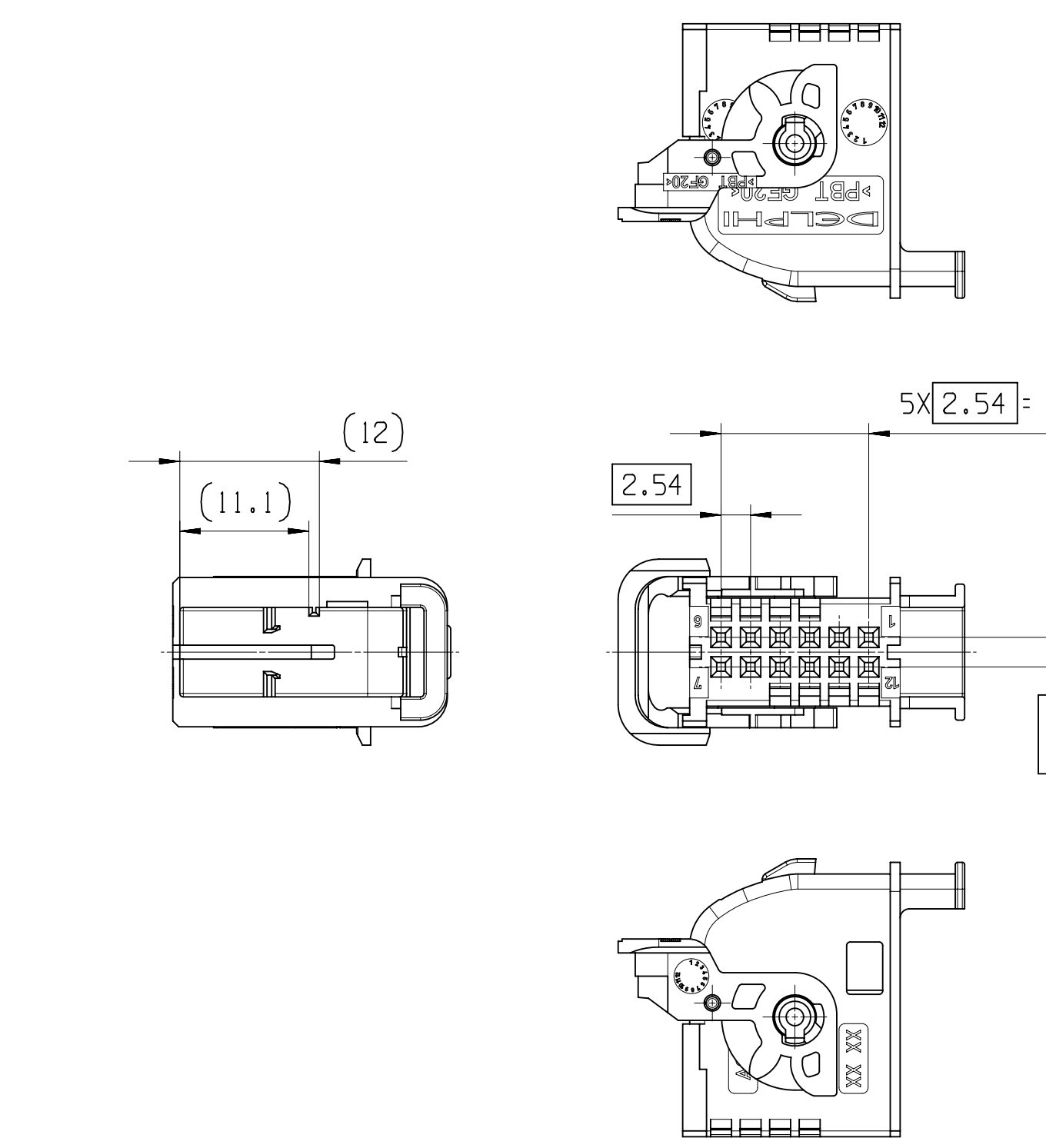

DIRECTION EXIT  
BUNDLE CABLE  
P/N - 13553389 CODE "A"

ASSOCIATED PARTS (FOR INFORMATION)		
DESCRIPTION	APTIV P/N	WIRE CROSS SECTION
MATING PART	13553126	-
MTS TERMINAL 0.63	15440177	0.35 mm <sup>2</sup>

APTIV NUMBER	CODE	DESCRIPTION	APTIV PART NUMBER	WEIGHT (kg)	MATERIAL	COLOR	NO.
13553390	B	ASSY SHELL+LEVER CODE "B"	13553388	tbd	PBT-GF20	-	1
		HSG FOR FEM. TERM. CODE "B"	13553386		PBT-GF20	GREY	2
13553389	A	ASSY SHELL+LEVER CODE "A"	13553122	tbd	PBT-GF20	-	1
		HSG FOR FEM. TERM. CODE "A"	13553120		PBT-GF20	BLACK	2

NOTE	SPECIFICATIONS
1	COVER AND LEVER ACCORDING TO APTIV SPECIFICATION: CAGE XXXX/XXX
2	COVER AND LEVER ACCORDING TO: - TEMPERATURE CLASS TX - ENGINE VIBRATOR CLASS VX - SEALING CLASS EX
3	USER'S MANUAL: 13553124-CUS72
4	DELIVERY CONNECTOR WEIGHT : SEE TABLE
5	NO WAFER HINGE OR WAFER HINGE BROKEN ALLOWED
6	VISUAL DEFECTS ON NO FUNCTIONAL AREAS ALLOWED
△	MATERIAL CODE
△	TOOL CAVITY NUMBER
△	PART REVISION NUMBER
△	WAY NUMBERS
△	SUPPLIER LOGO
△	PART NUMBER
△	DATE CLOCK

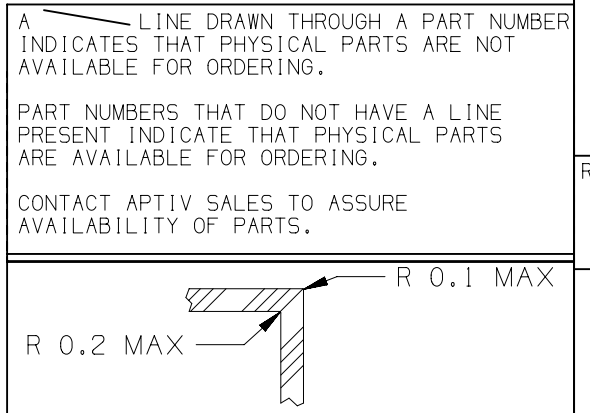

DR. TYPE	CUSTOMER PART DRAWING
REV. CODE	01
SEE TABLE	SEE TABLE
VOLUME (TOP)	---
ROUTING	---

UNLESS OTHERWISE SPECIFIED  
GENERAL TOLERANCES ACCORDING TO:  
SEE CHART  
GD&T ACCORDING TO:  
150 1101

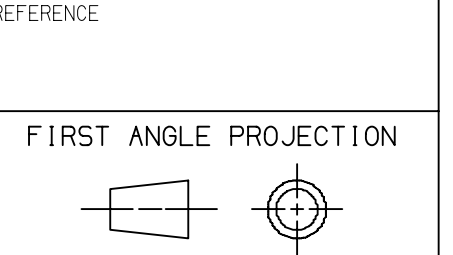

DO NOT SCALE  
USE MATH DATA

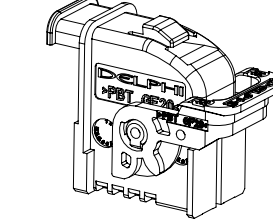

**APTIV**  
CONNECTION SYSTEMS  
Dharmat, India  
COPYRIGHT 2021 APTIV, ALL RIGHTS RESERVED.  
THIS DRAWING IS THE PROPERTY OF APTIV AND CONTAINS APTIV CONFIDENTIAL INFORMATION. THE REPRODUCTION, DISTRIBUTION AND UTILIZATION OF THIS DOCUMENT OR ITS RELATED CAD DATA, AS WELL AS COMMUNICATION OF ANY CONTENT TO OTHERS, WITHOUT EXPRESS AUTHORIZATION, IS PROHIBITED.

DR	P.BALAJI	DATE	31DE21
APVD1	LAGUETTE MAURICE	31DE21	
APVD2	LAGUETTE MAURICE	31DE21	
APVD3			
APVD4			
APVD5			

MATERIAL:  
SEE TABLE  
DRAWING NAME:  
ASSY SHELL + LEVER + HOUSING FOR CONNECTOR SPIRAL WIRE  
DRAWING NUMBER:  
13553124  
SIZE: A0 SCALE: 5:1 FRAME NO: 1 SHEET NO: 1 OF 1 STG REV: N/P