

SYMBOL DEFINITION				MISSING SYMBOLS		REVISION HISTORY		AUTH	
A DIMENSION WITHOUT AN INSPECTION REPORT SYMBOL DOES NOT REQUIRE INSPECTION. IT MAY BE CONTROLLED ON THE INDIVIDUAL COMPONENT DRAWING.				TOTAL NO OF INSPECTIONS REQUIRED		NO MISSING SYMBOL NUMBER		445752 BZY ZK HSB	
				18					
				LAST NO. USED					
				17					

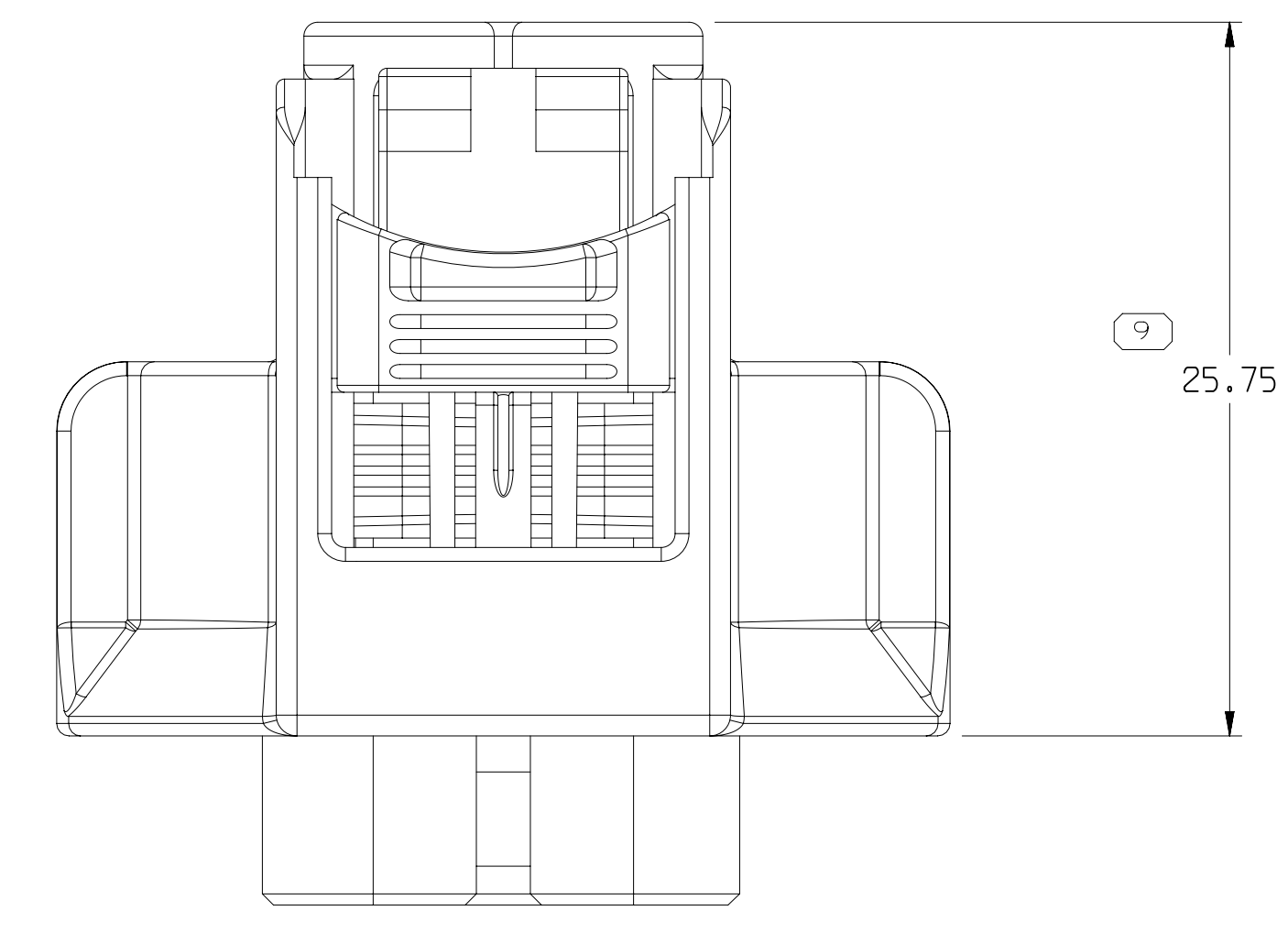

ONLY FOR CHINA ACS USE

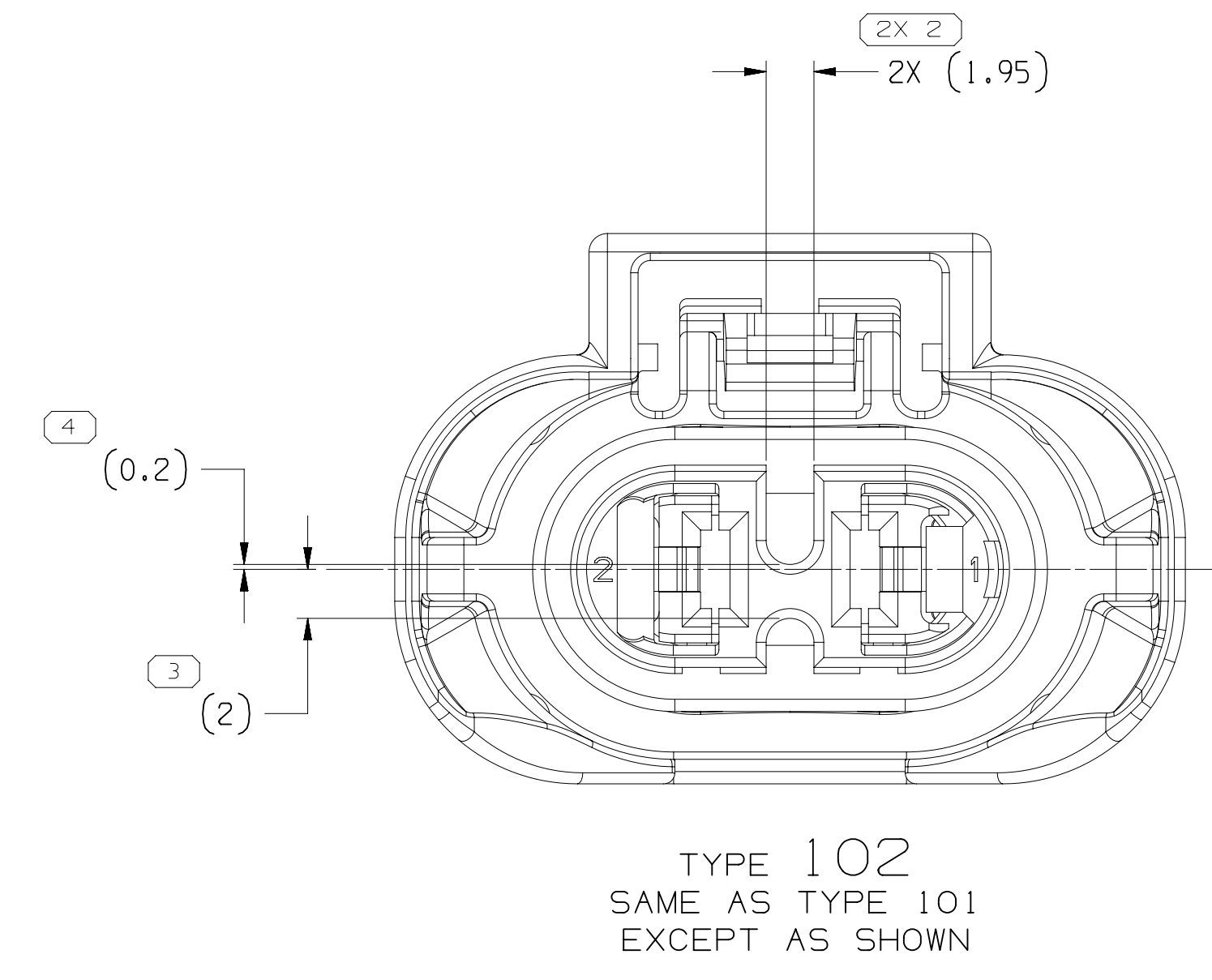
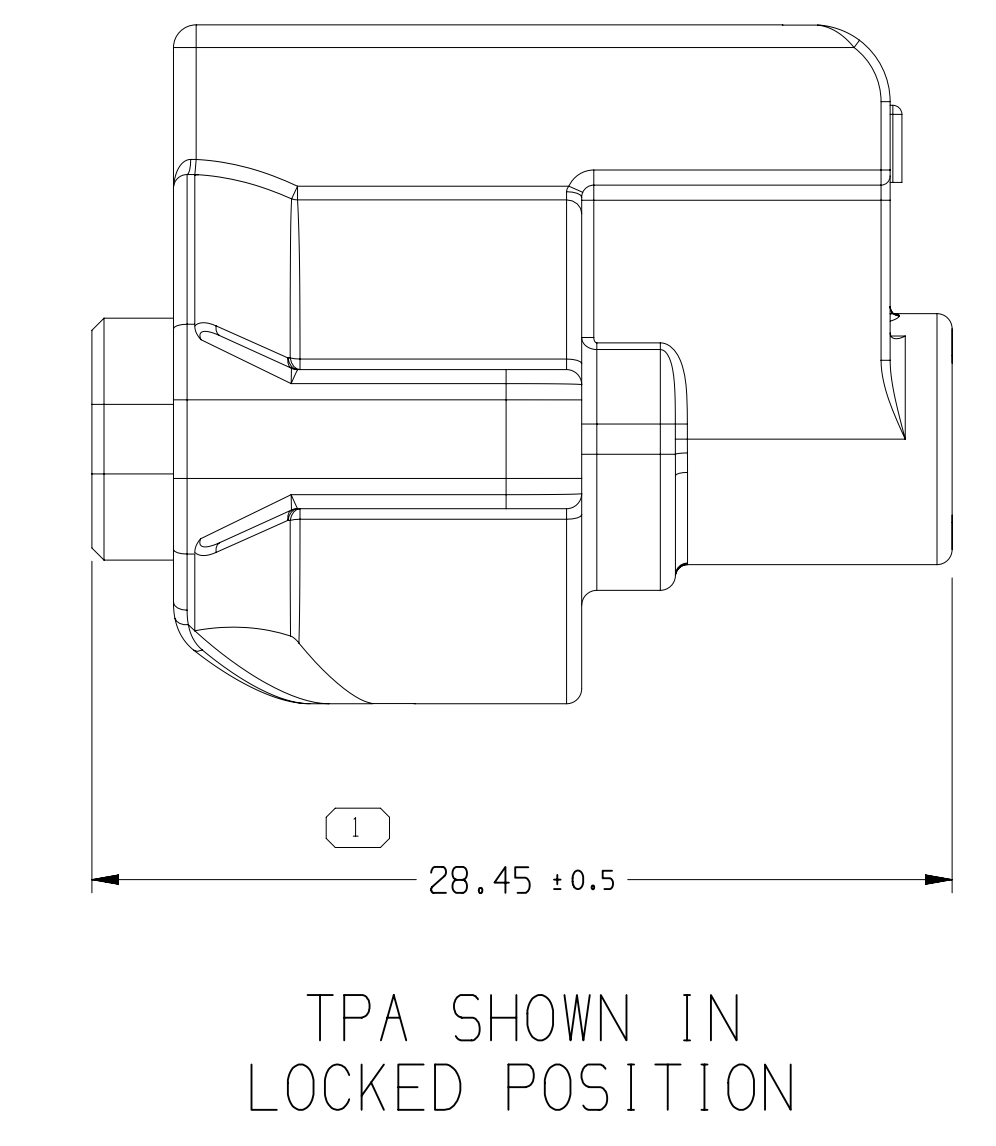
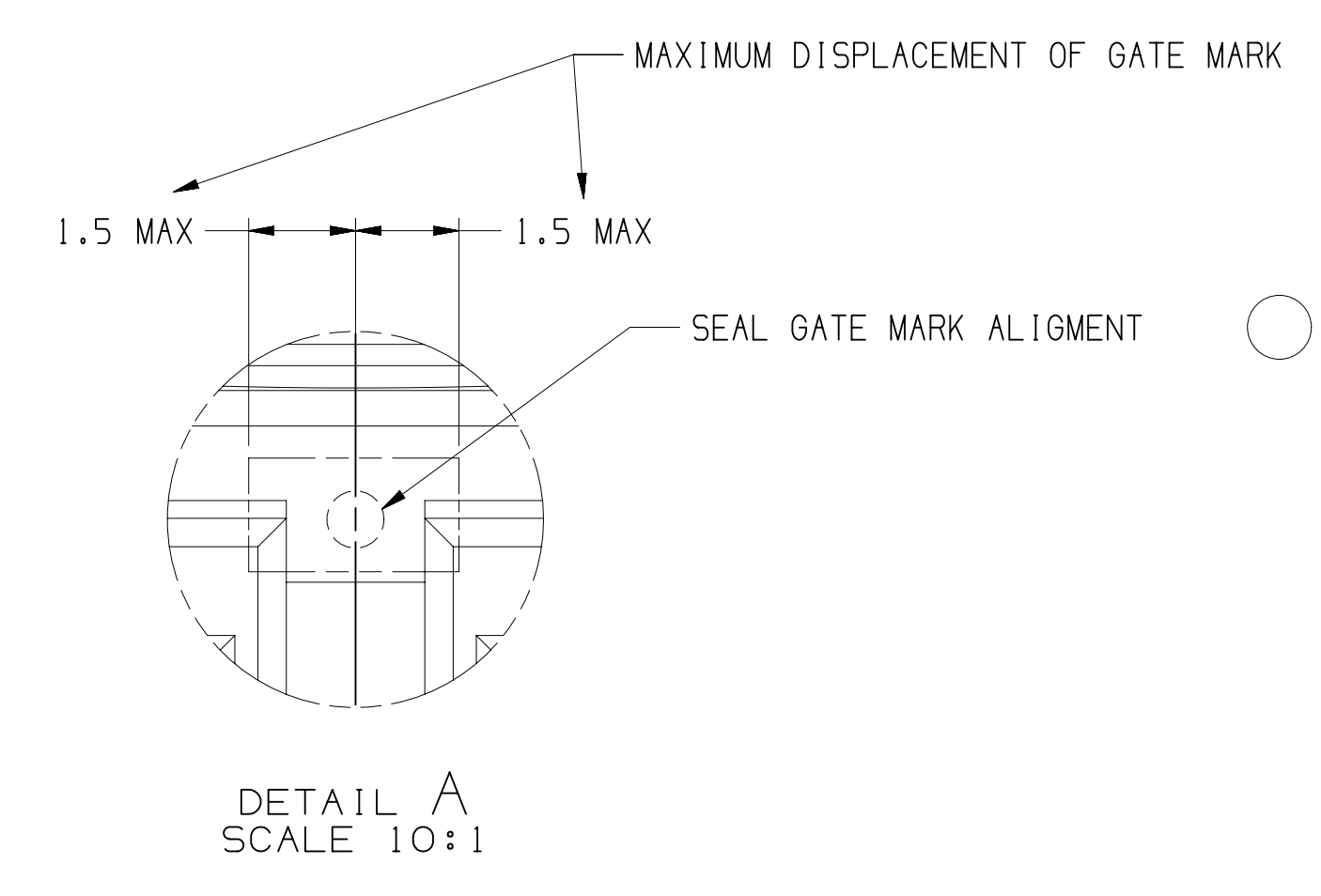
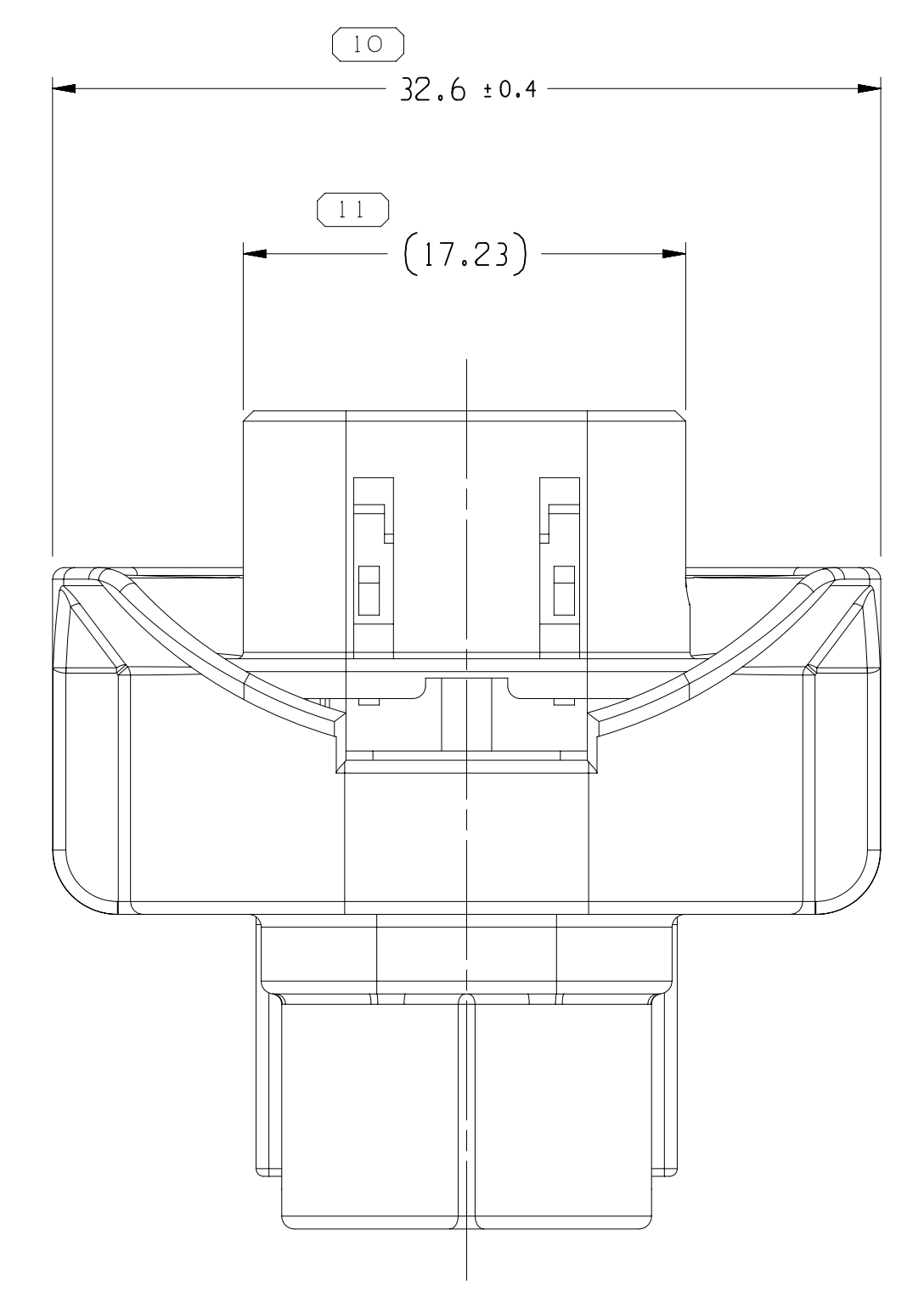
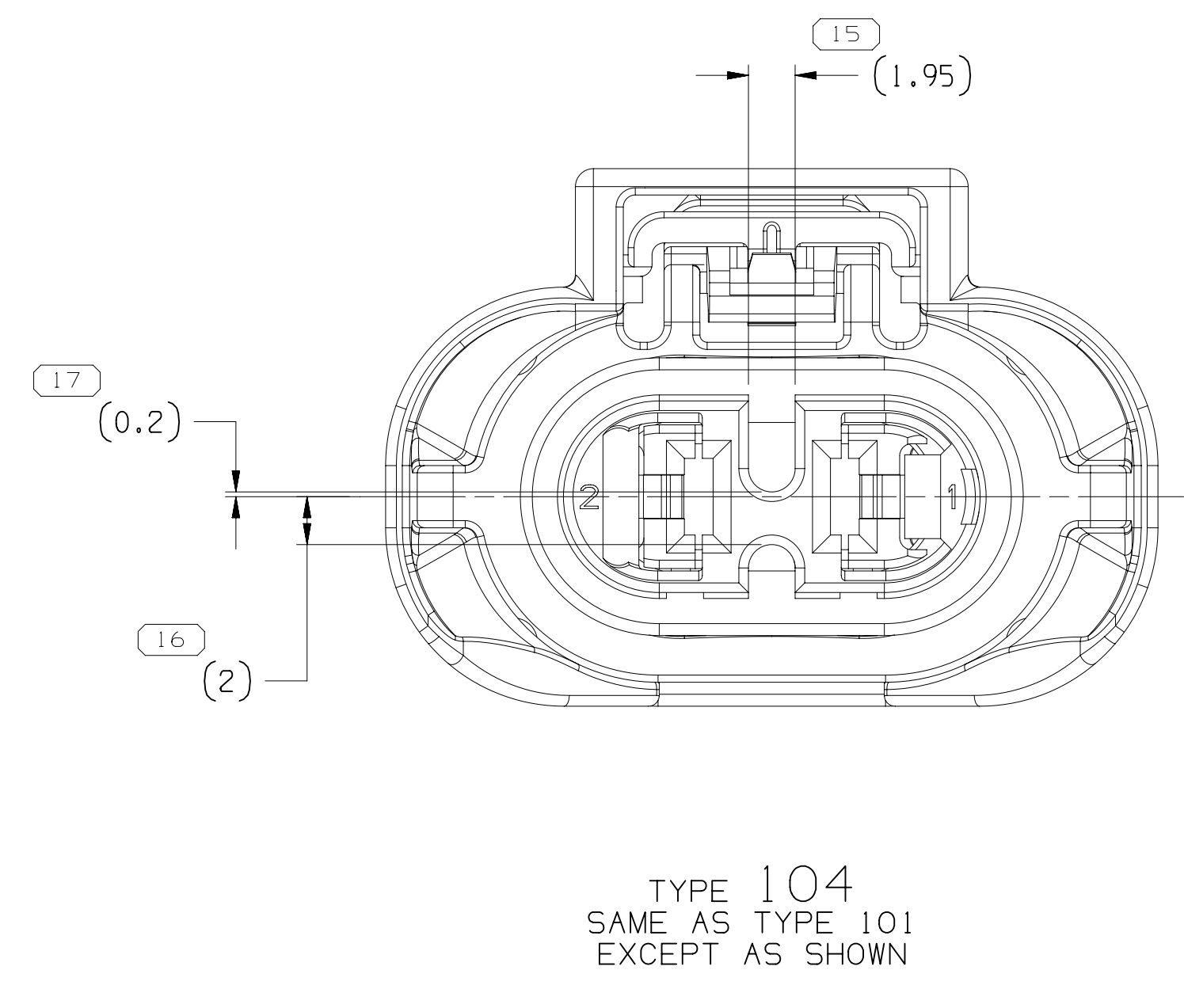
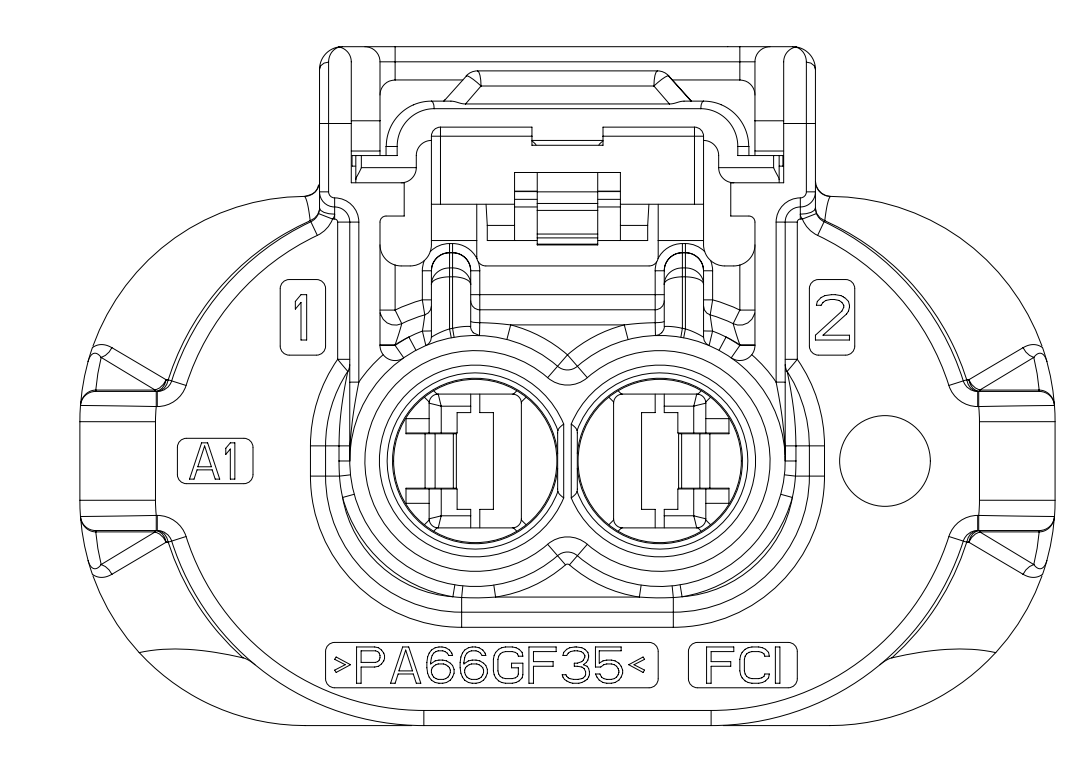
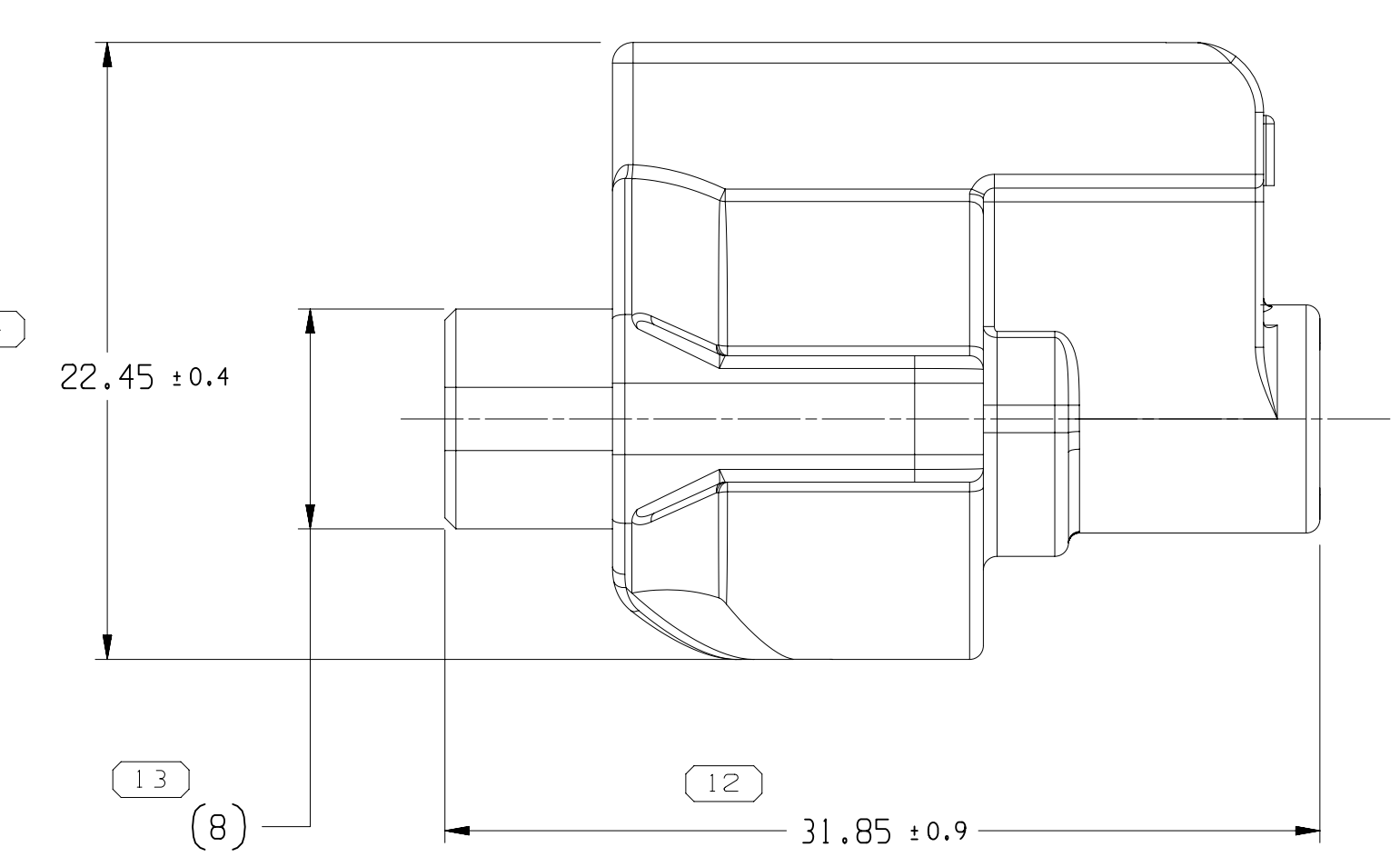
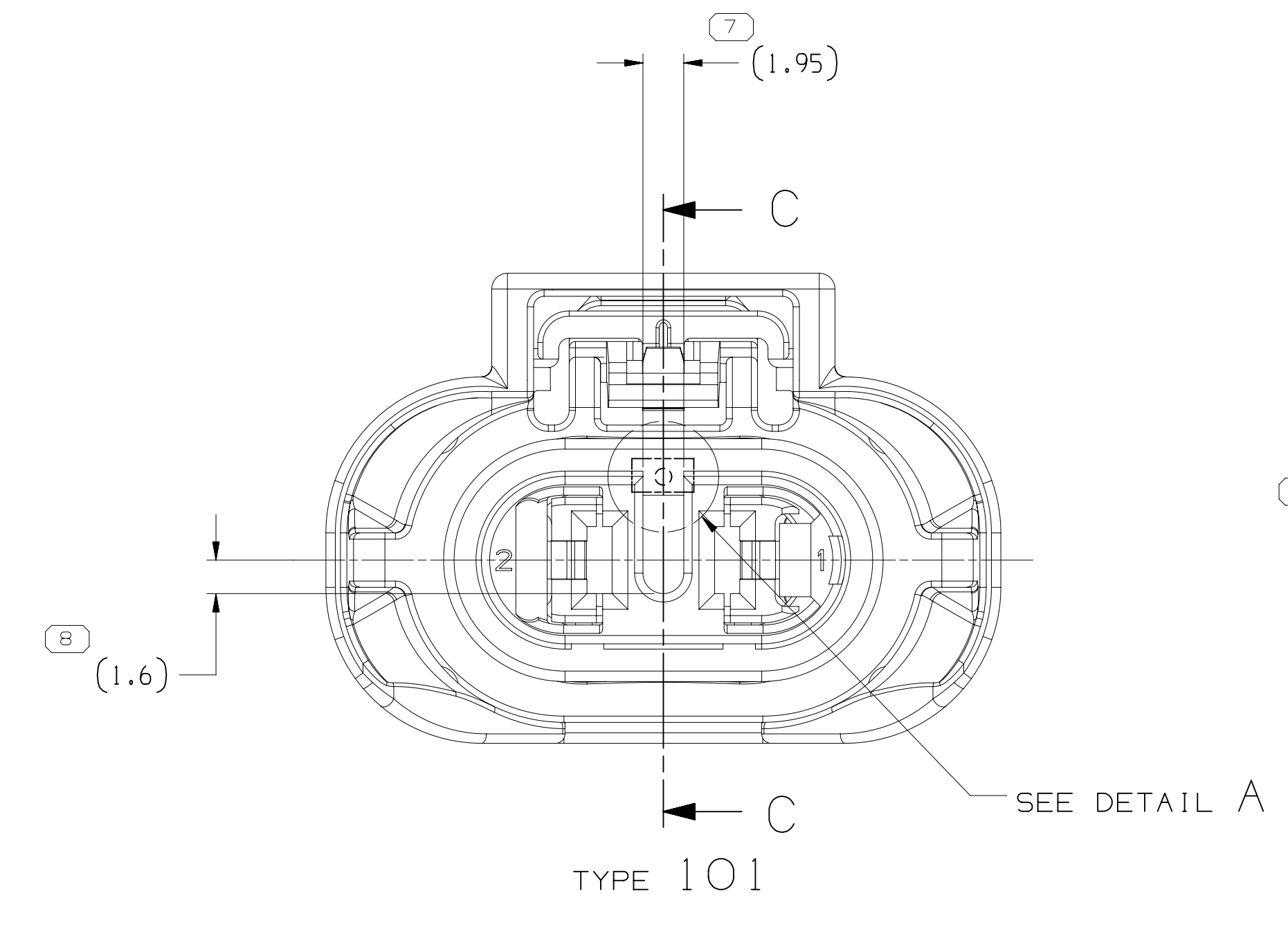
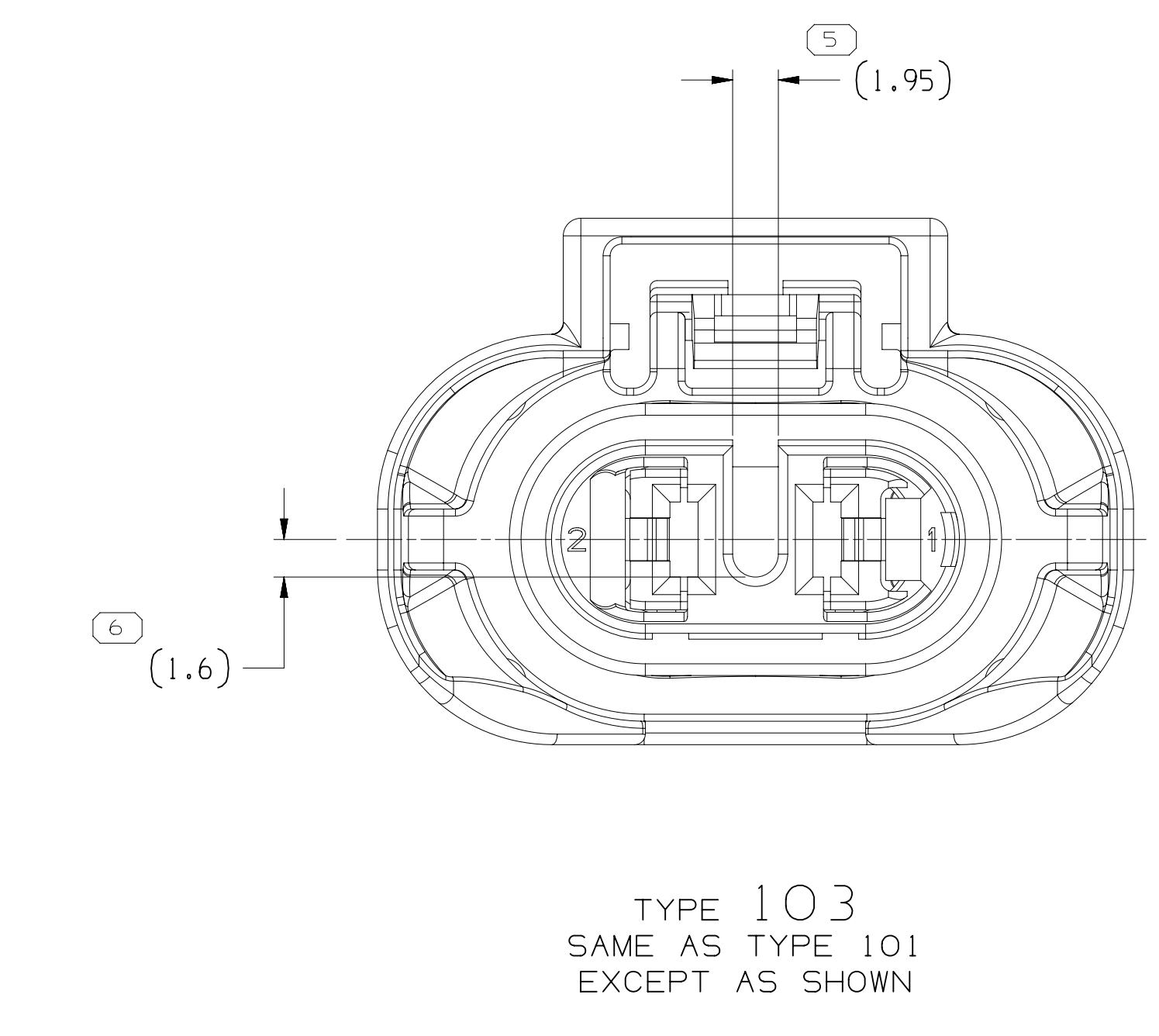
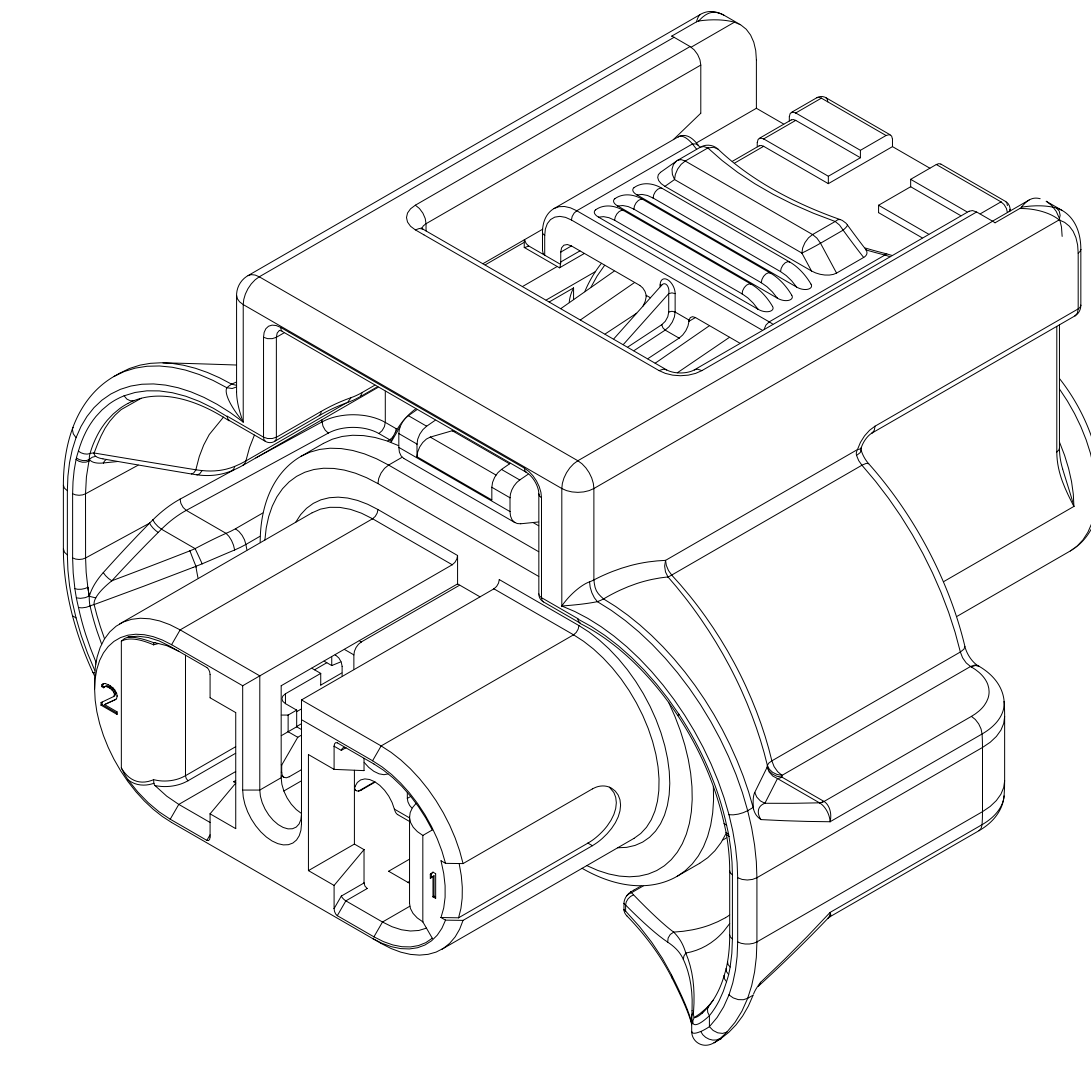
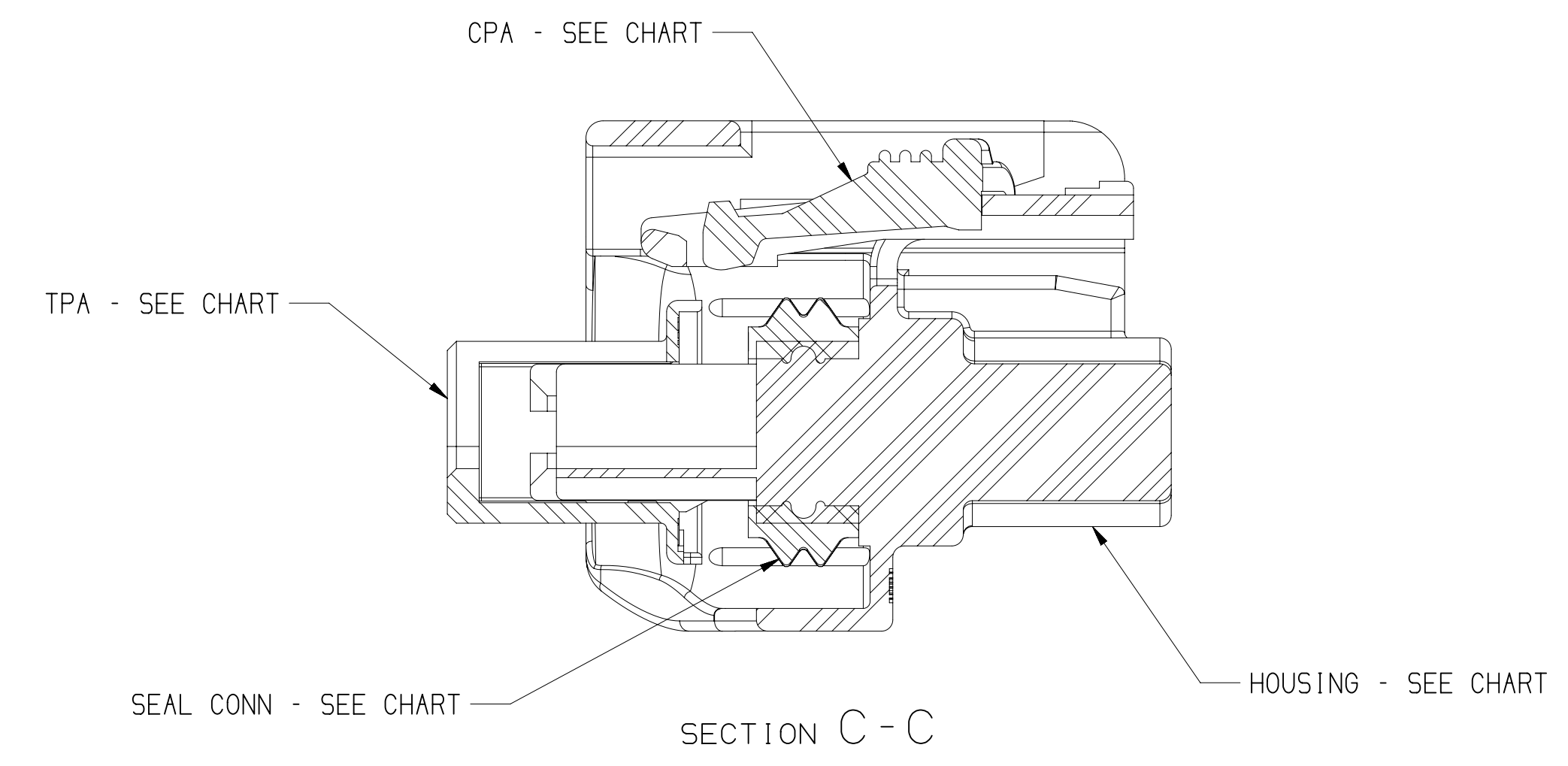

- NOTES
- UNLESS OTHERWISE SPECIFIED AND/OR INDICATED:  
DIMENSIONS ARE TO FACE OF VIEW SHOWN AND AUTOMATICALLY ROUNDED BY COMPUTER FOR INSPECTION (SEE MATH MODEL FOR PRECISE DIMENSIONS). FOR ALL OTHER DIMENSIONS NOT SHOWN BUT REQUIRED FOR TOOL BUILD, SEE MATH MODEL FOR PRECISE TOOL PATH DATA.
  - THIS PRODUCT IS NOT CATEGORIZED AS AN APPEARANCE ITEM, MINOR IMPERFECTIONS INCLUDING, BUT NOT LIMITED TO, FLOW MARKS, COLOR BLEMISHES, GATE VESTIGE, AND SOFT FLASH THAT DO NOT AFFECT THE FIT, FORM, OR FUNCTION OF THE PART ARE PERMISSIBLE PER DPNP-4.7-CS-01.
  - FOR APPLICATION DATA SEE THE INDIVIDUAL APPLICATION DRAWINGS.
  - SEAL GATE INJECTION MARK TO BE ALIGNED WITH CONNECTOR LOCK CENTER LINE

33517462	104	01	AA	F984 300	33510288	33509794	33501730	33503756
13818129	103	01	AC	F194 300	33510288	33509793	33501730	N/A
33501572	102	01	AC	F294 300	33510288	33509794	33501730	N/A
13930730	101	02	AC	F094 300	33510288	33509793	33501730	33503756
DELPHI PART NO	TYPE	REV	N/P	MVL PART NO	HOUSING	TPA	SEAL	CPA

DIMENSIONAL RANGE (MM)		TOLERANCE UNLESS OTHERWISE SPECIFIED	
FROM	TO	TOLERANCE	ANGULAR TOLERANCE
> 0	> 30	± 0.4	± 2°
> 30	> 70	± 0.5	
> 70	> 100	± 0.6	
> 100	> 150	± 0.8	
> 150	> 200	± 1	
> 200	> 250	± 1.2	
> 250	> 300	± 1.5	
> 300	> 400	± 2	

**APTIV**  
CONNECTION SYSTEMS  
Anqing, China  
COPYRIGHT 2023 APTIV. ALL RIGHTS RESERVED.  
THIS DRAWING IS THE PROPERTY OF APTIV AND CONTAINS APTIV CONFIDENTIAL INFORMATION. THE REPRODUCTION, DISTRIBUTION AND UTILIZATION OF THIS DOCUMENT OR ITS RELATED CAD DATA, AS WELL AS COMMUNICATION OF ANY CONTENT TO OTHERS, WITHOUT EXPRESS AUTHORIZATION, IS PROHIBITED.

DATE: 31-JL-20  
DR: BAI ZAIYUN  
APVD1: ZHOU KEVIN  
APVD2: HUANG SUIBIN  
APVD3: [blank]  
APVD4: [blank]

THIS DOCUMENT IS IN ACCORDANCE WITH ASME Y14.5M-1994 AS MODIFIED BY THE 2018 GLOBAL DIMENSIONING AND TOLERANCING ADDENDUM-2018. SEPARATE PATTERNING OF FEATURES MAY BE MADE SEPARATELY REGARDLESS OF DATUM REFERENCES.

ALL DIMENSIONS ARE IN MILLIMETERS

STYLE: PART DRAWING  
VOLUME (CM): SEE CHART  
DISTR CODE: D

UNLESS OTHERWISE SPECIFIED

REFERENCE: PCC0558541

THIRD ANGLE PROJECTION  
DO NOT SCALE  
USE MATH DATA

DRAWING NUMBER: TAXI ASM CONN  
13933752  
SIZE: A0  
SCALE: 4:1  
FRAME NO: 1 OF 2  
SHEET NO: 1 OF 1  
STG: R  
REV: 01