

MALE HOUSING METAL PART ASSEMBLY

DETAIL F
SCALE 5:1

ADD STOPPER
SCALE 5:1

DETAIL D
SCALE 5:1

DETAIL E
SCALE 5:1

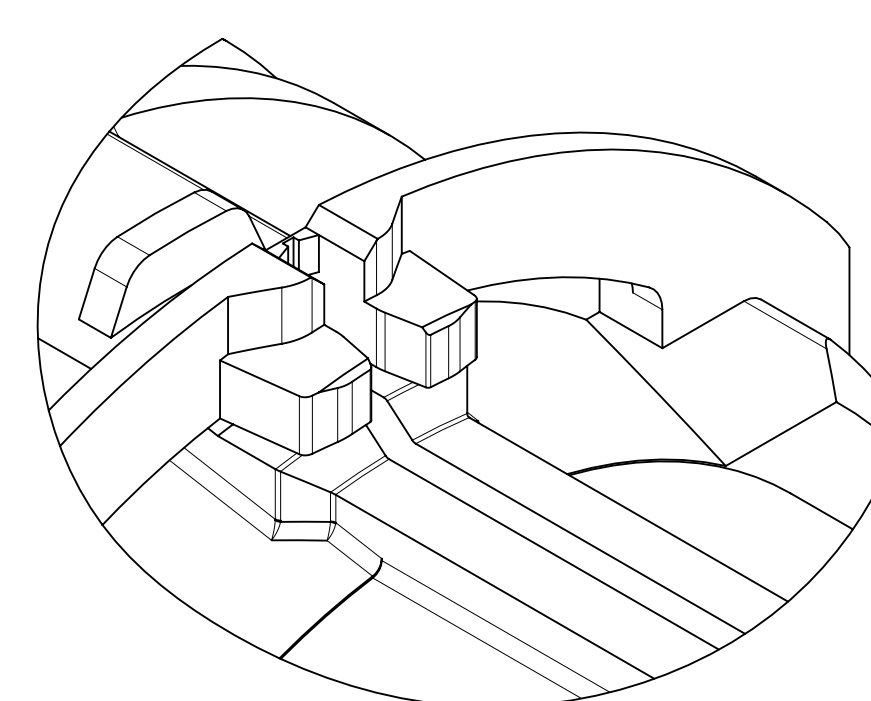

NOTE: SIDE BETWEEN (...) : SIDE METAL FOR INFO

DETAIL G
SCALE 5:1

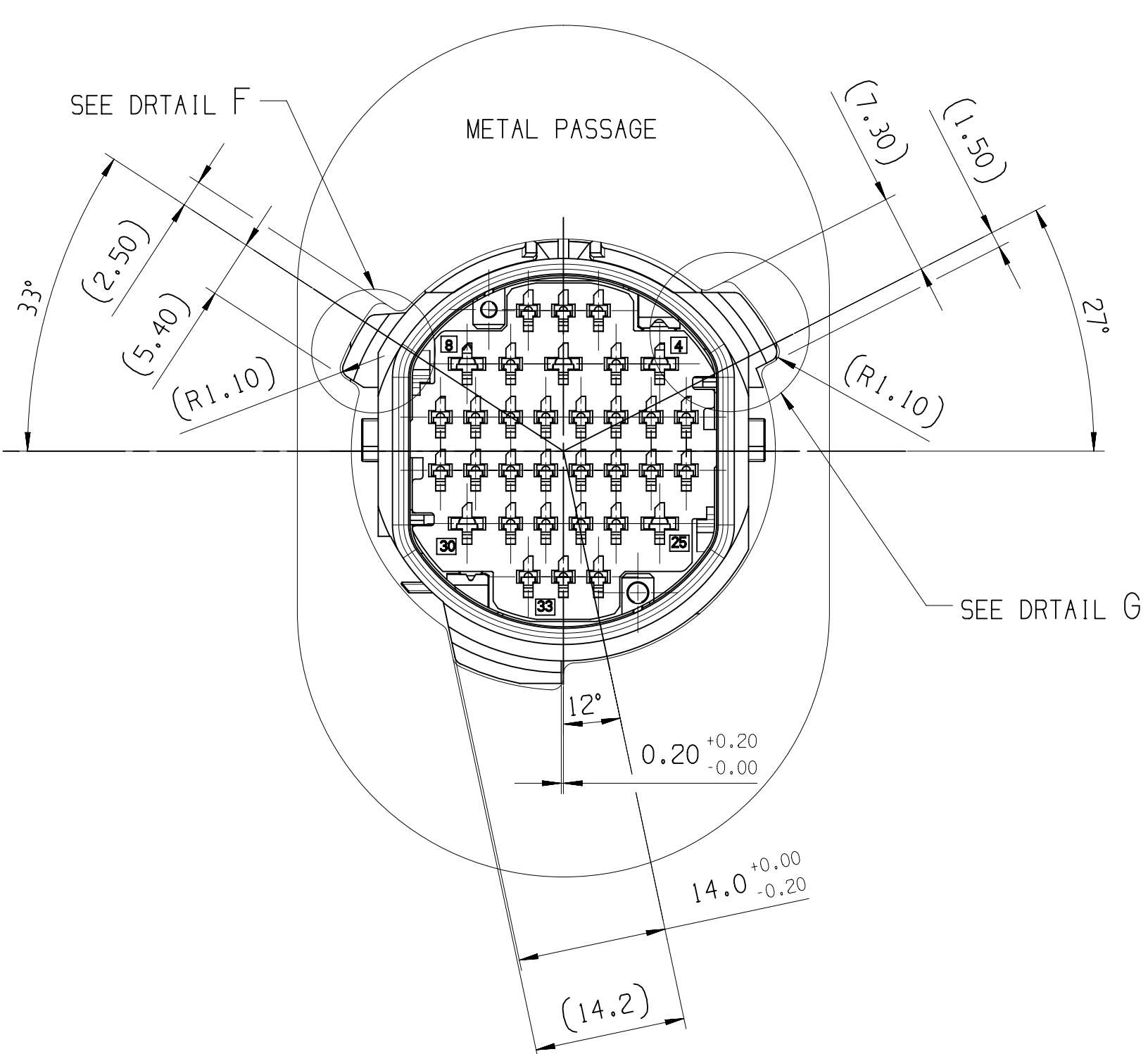
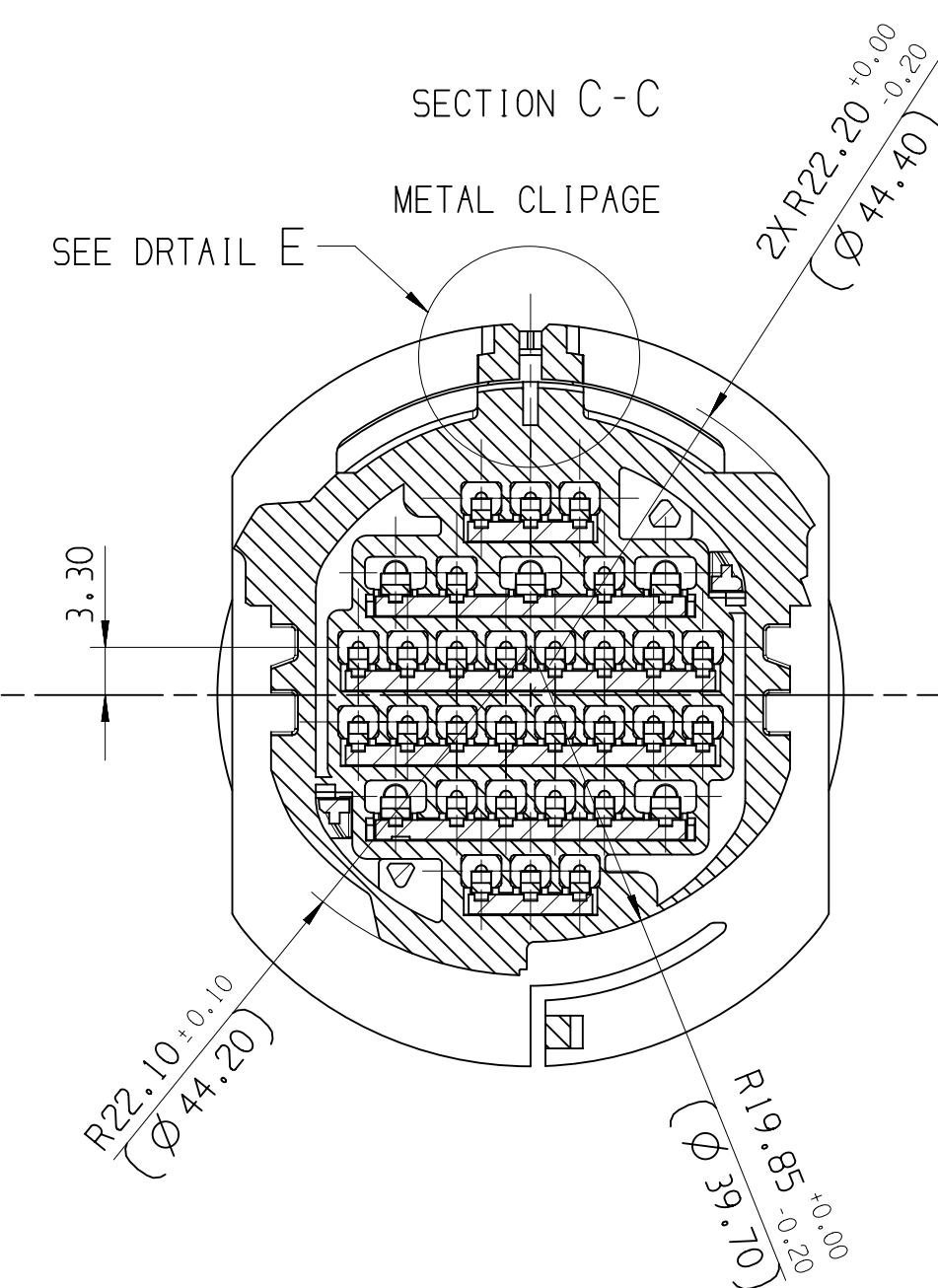
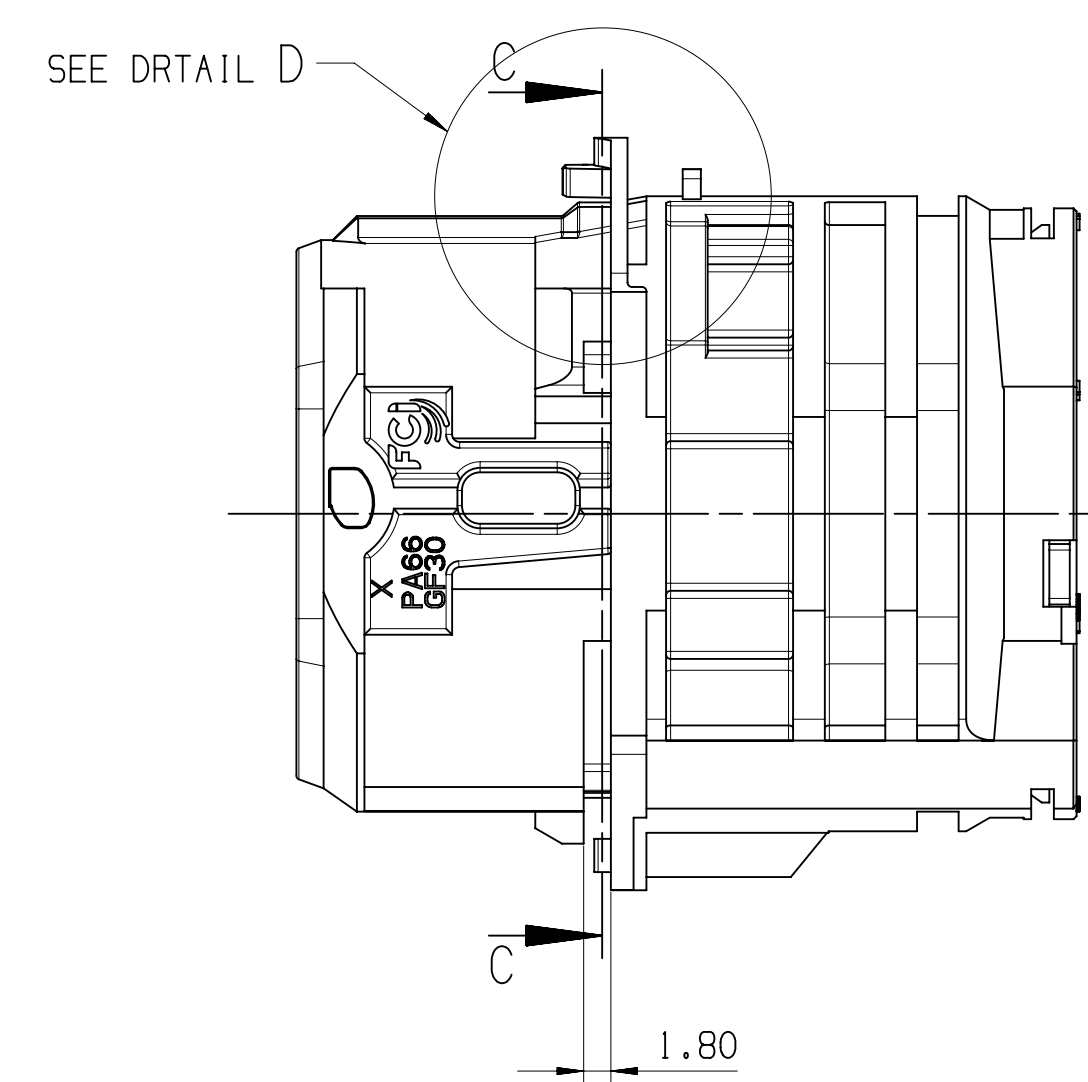
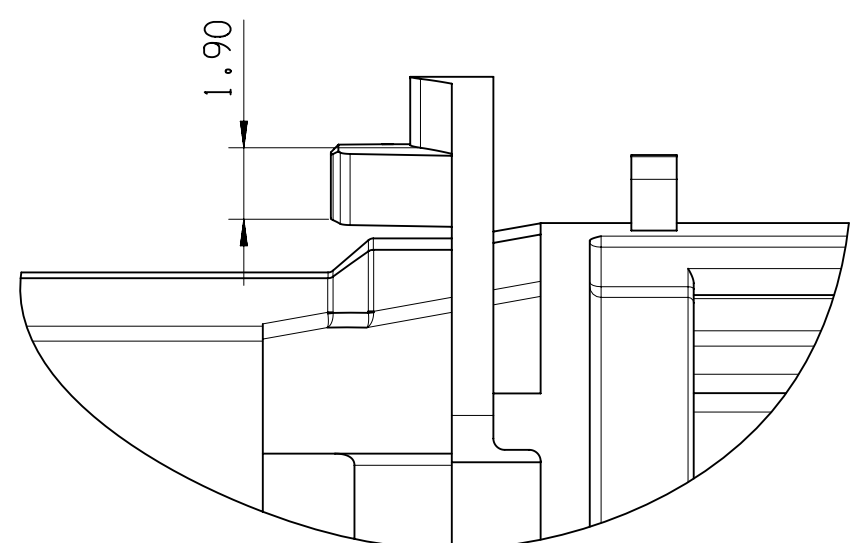
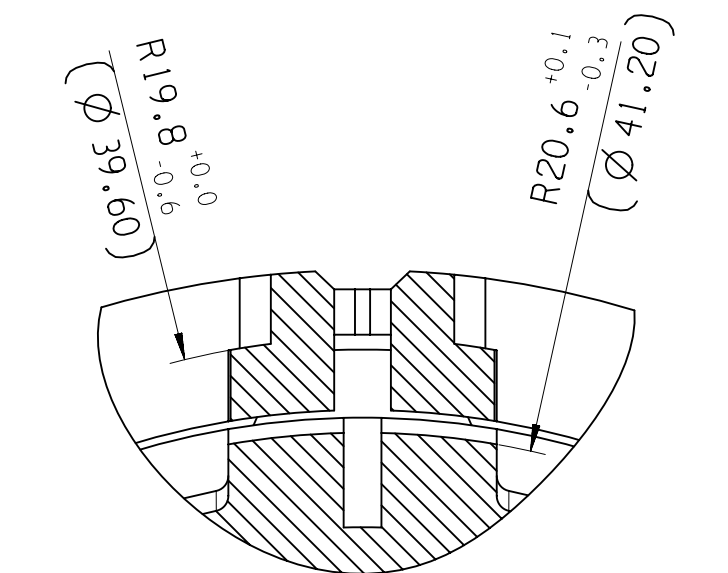
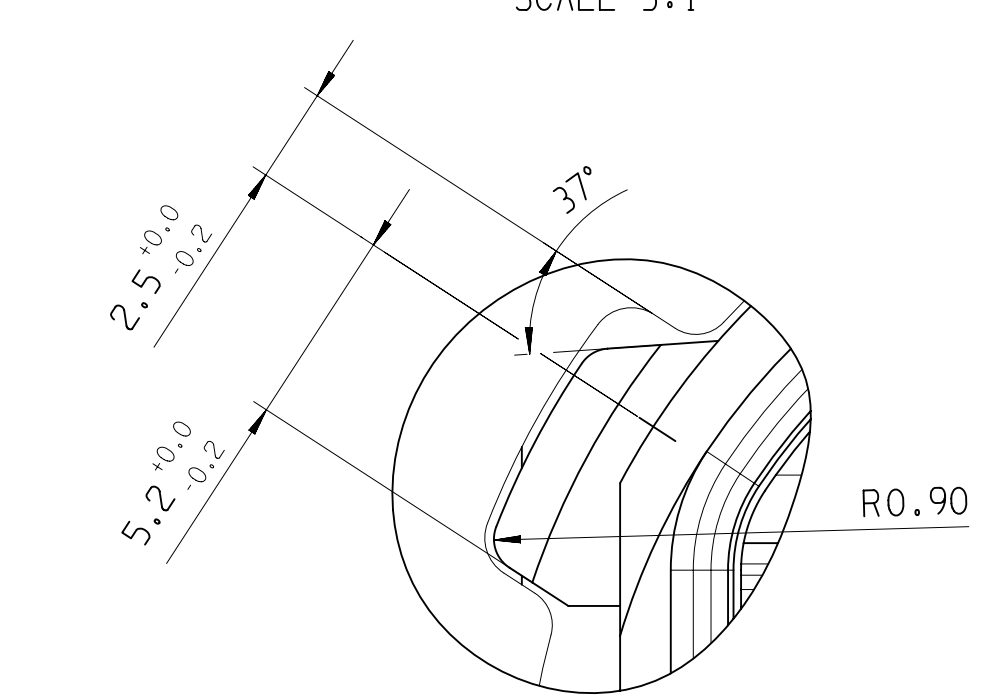
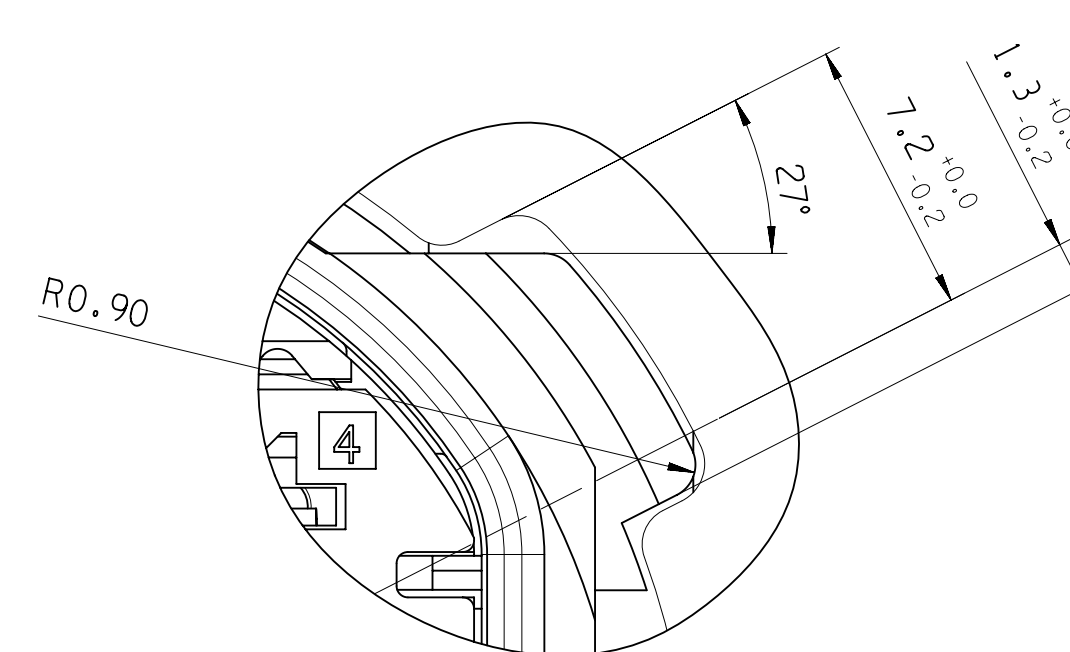

DIMENSIONS OF THE COUNTERPART AND HANDLING AREAS

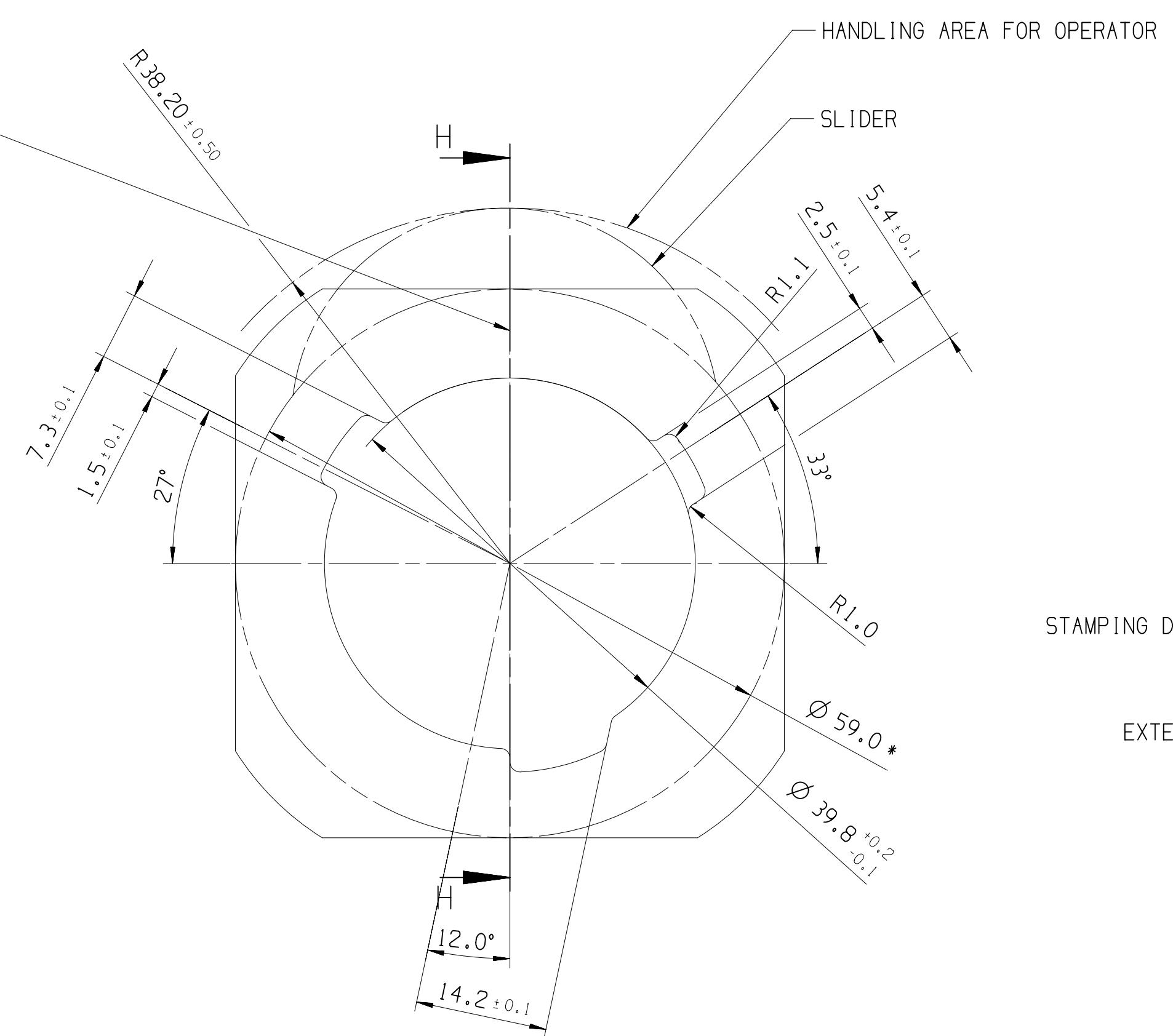
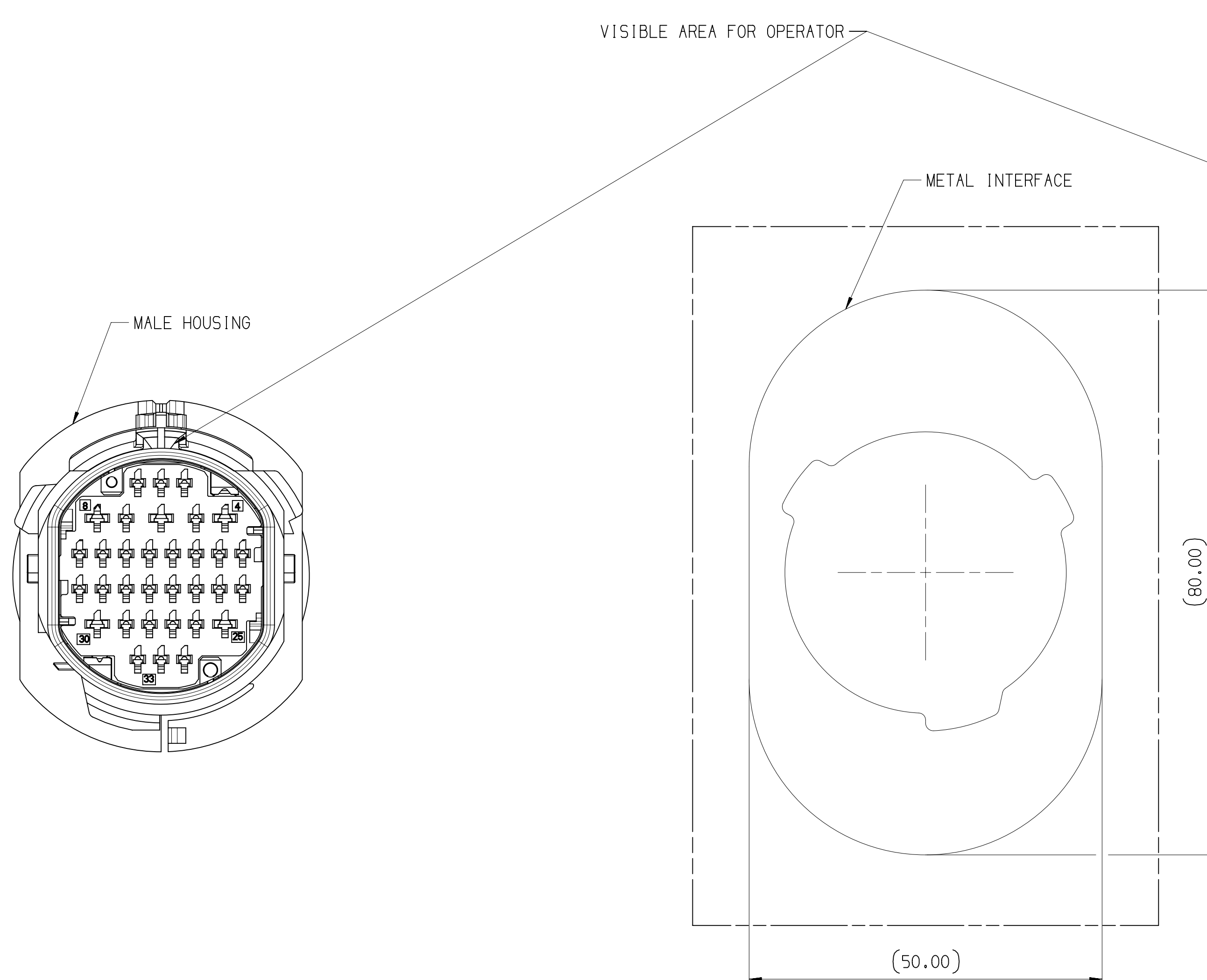

SECTION H-H

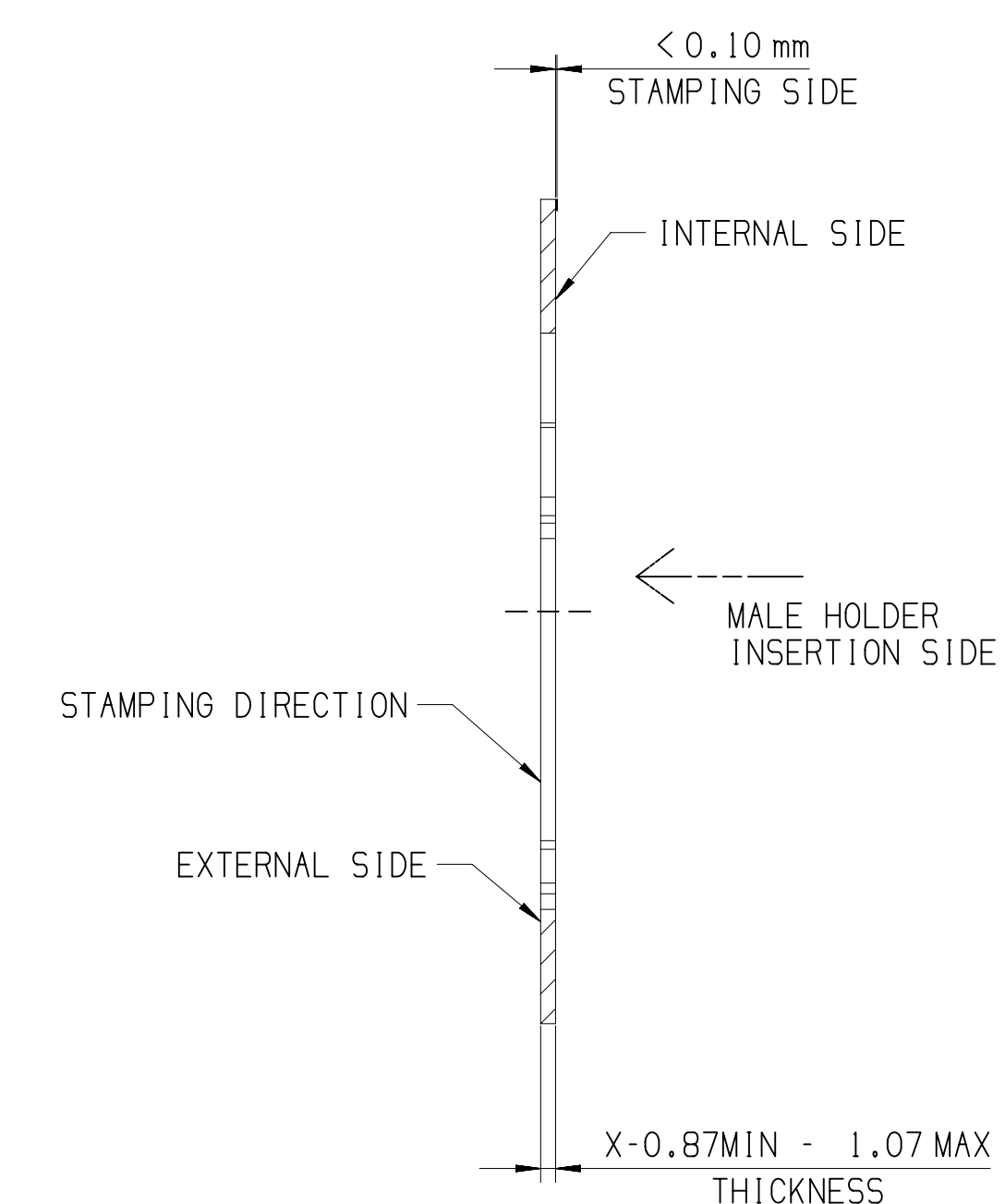

* CLEARANCE AREA FOR EXTERNAL GASKET, AFTER MATING OF MALE AND FEMALE HOLDER

NOTE: FIT DURING VALIDATION OF MIN / MAX WIRE CUT CALIBERS. MOUNTING ON SHEET WILL BE EASIER WITH A MINIMUM TRENDY THICKNESS!

| DIM TO CHECK | DIMENSIONAL RANGE (MM) | | TOLERANCE UNITS |
|------------------------|------------------------|-------|-----------------|
| | FROM | TO | |
| Ø DIM FOR HELP | > 0 | > 20 | ± 0.15 |
| THEORETIC DIM | > 20 | > 30 | ± 0.2 |
| | > 30 | > 70 | ± 0.3 |
| ANGULAR TOLERANCE | > 100 | > 150 | ± 0.4 |
| | > 150 | > 200 | ± 0.5 |
| SHARP CORNER TOLERANCE | > 200 | > 300 | ± 0.6 |
| | > 300 | > 400 | ± 0.8 |

| DATE | STATUS | REV | BY | CHK | ZONE | REVISION HISTORY | AUTH | DR | APVD | APVD | |
|--------|--------|-----|----|-----|------|------------------|------|----|-------|-------|-------|
| 04NO20 | R | 01 | | | | INITIAL RELEASE | | | P.BAL | J.LAL | L.LEC |

| GENERAL TOLERANCES ACCORDING TO: | SEE CHART |
|----------------------------------|-----------|
| GD&T ACCORDING TO: | 150 1101 |

• APTIV •
CONNECTION SYSTEMS
Chennai, India
COPYRIGHT 2020 APTIV. ALL RIGHTS RESERVED.
THIS DRAWING IS THE PROPERTY OF APTIV AND CONTAINS APTIV CONFIDENTIAL INFORMATION. THE REPRODUCTION, DISTRIBUTION AND UTILIZATION OF THIS DOCUMENT OR ITS RELATED CAD DATA, AS WELL AS COMMUNICATION OF ANY CONTENT TO OTHERS, WITHOUT EXPRESS AUTHORIZATION, IS PROHIBITED.
CE PLAN EST LE PROPRIETE DE APTIV ET CONTIENT DES INFORMATIONS APTIV CONFIDENTIELLES. LA REPRODUCTION, LA DISTRIBUTION ET L'UTILISATION DE CE DOCUMENT OU DE SES DONNEES INFORMATIQUES SONT ANSI QUE LA COMMUNICATION DE TOUT CONTENU A AUTRI, SANS AUTORISATION EXPRESSE EST INTERDITE.

| DR | DATE |
|-----------|--------|
| P.BALAJI | 04NO20 |
| J.LALU | 04NO20 |
| L.LECLERE | 04NO20 |
| APVD3 | |
| APVD4 | |
| APVD5 | |

SUBSTANCES OF CONCERN AND RECYCLED CONTENT PER APTIV 104H001
MATIERES PROHIBITES ET CONTENU RECYCLABLE SELON APTIV 104H001

MATERIAL
SEE TABLE

DRAWING NAME
33WAY MALE CONNECTOR

DRAWING NUMBER
33521535

SIZE SCALE FRAME NO SHEET NO STR REV NUP
A0 2:1 1 OF 1 2 OF 2 R 01

Lect: 165724