

SYMBOL DEFINITION

A DIMENSION WITHOUT AN INSPECTION REPORT SYMBOL DOES NOT REQUIRE INSPECTION. IT MAY BE CONTROLLED ON THE INDIVIDUAL COMPONENT DRAWING.

TOTAL NO OF INSPECTIONS REQUIRED	10
LAST NO. USED	10

ASSOCIATED PARTS

N°	DESIGNATION	DELPHI PN
1	PLUG 800	35098453

MISSING SYMBOLS		DWG STATUS					REVISION HISTORY		AUTH	DR	APVD 1	APVD 2
NO MISSING SYMBOL NUMBER	DATE	STG	REV	N/P	CHG	ZONE	INITIAL RELEASE	447476		YDD	ART	
	13JA22	R	01	-	-	-						

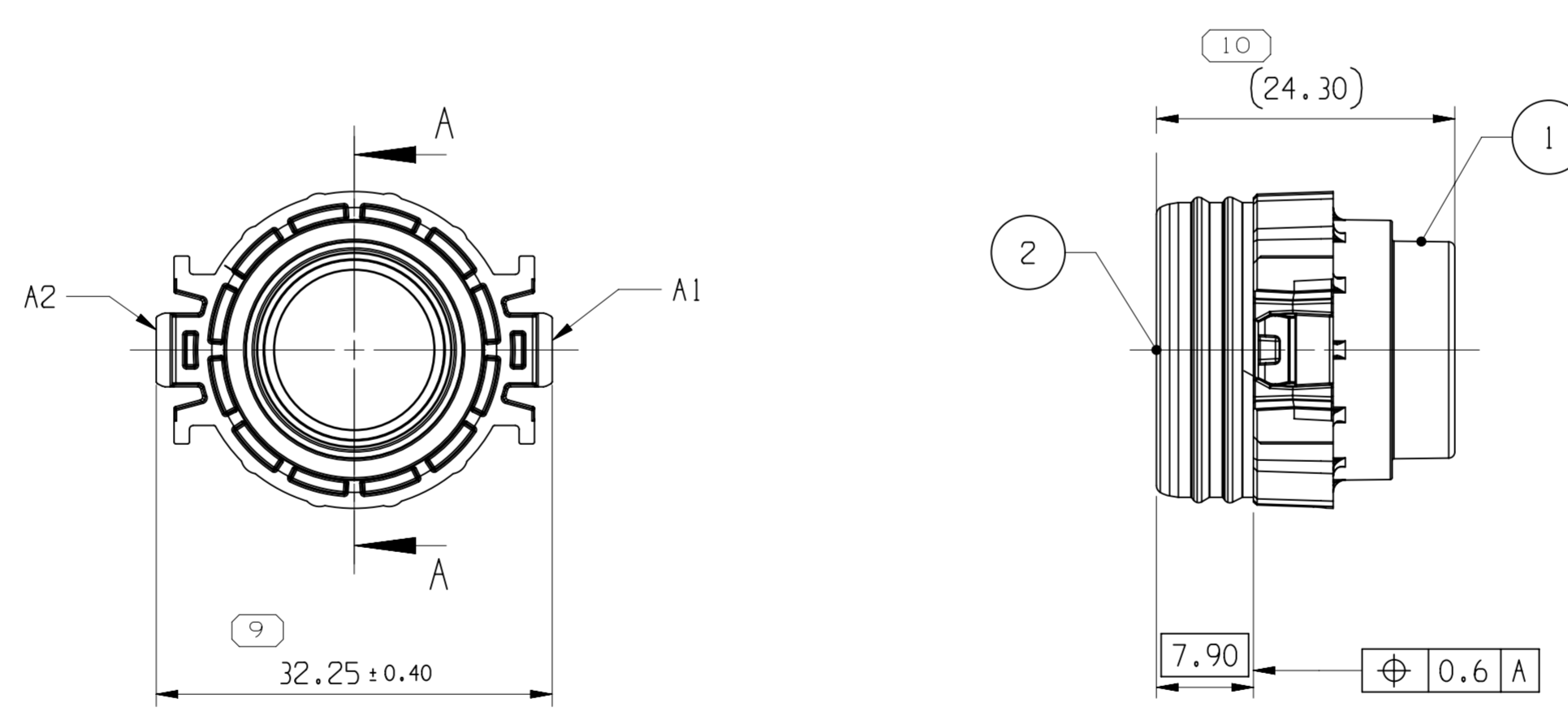
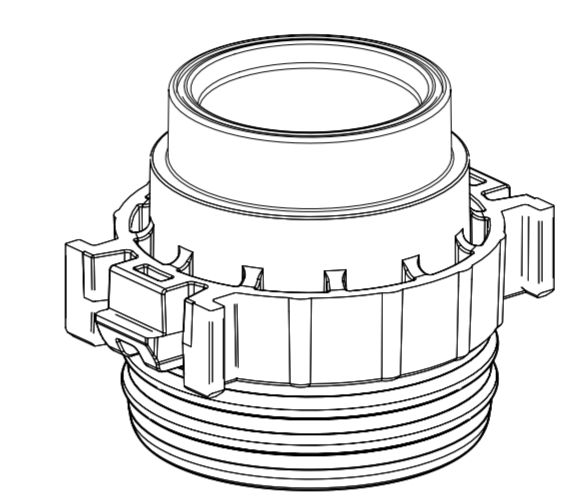
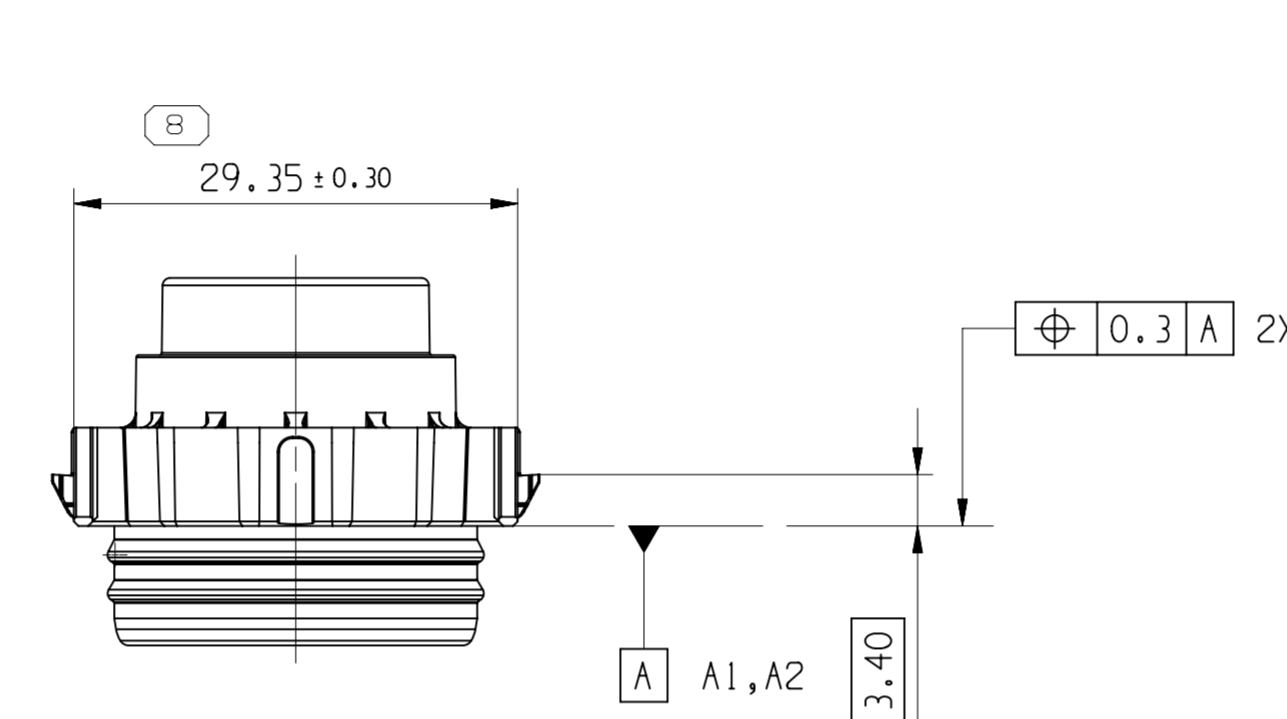

NOTES

- UNLESS OTHERWISE SPECIFIED AND/OR INDICATED:
DIMENSIONS ARE TO FACE OF VIEW SHOWN AND AUTOMATICALLY ROUNDED BY COMPUTER FOR INSPECTION (SEE MATH MODEL FOR PRECISE DIMENSIONS). FOR ALL OTHER DIMENSIONS NOT SHOWN BUT REQUIRED FOR TOOL BUILD, SEE MATH MODEL FOR PRECISE TOOL PATH DATA. DRAFT IS 0.5° MAX ON ALL OUTSIDE SURFACES. MAX. BURR 0.05.
- THIS DRAWING IS USED FOR CHN LOCALIZATION TOOL.

PART NO	REV.	TYPE	DESCRIPTION
35099248	01	101	SQUEEZING SHIELD 50MMSQ
35099247	01	102	SQUEEZING SHIELD 35MMSQ

DIMENSIONAL RANGE (MM)	TOLERANCE UNLESS OTHERWISE SPECIFIED	CHART	M
FROM TO			
> 0 > 6	±0.1		
> 6 > 30	±0.2		
> 30 > 70	±0.3		
> 70 > 120	±0.4		
> 120 > 160	±0.45		
> 160 > 200	±0.55		
> 200 > 250	±0.7		
> 250 > 315	±0.85		
> 315 > 400	±1.05		

APERTIV
CONNECTION SYSTEMS
Anting, China
COPYRIGHT 2022 APERTIV. ALL RIGHTS RESERVED.

THIS DRAWING IS THE PROPERTY OF APERTIV AND CONTAINS APERTIV CONFIDENTIAL INFORMATION. THE REPRODUCTION, DISTRIBUTION AND UTILIZATION OF THIS DOCUMENT OR ITS RELATED CAD MATH DATA, AS WELL AS COMMUNICATION OF ANY CONTENT TO OTHERS, WITHOUT EXPRESS AUTHORIZATION, IS PROHIBITED.

DR: YAN.DONGDONG
APVD1: MA.ARTHUR
APVD2: GAO.LINK
APVD3: GAO.LINK
APVD4: GAO.LINK
APVD5: GAO.LINK

DATE: 13JA22

UNLESS OTHERWISE SPECIFIED THIS DOCUMENT IS IN ACCORDANCE WITH ASME Y14.5-2009. SEE DELPHI ENGINEERING DESIGN STANDARD B6 2017 FOR ISO 1101:2004 RECONCILIATION REQUIREMENTS.

ALL DIMENSIONS ARE IN MILLIMETERS

THIRD ANGLE PROJECTION

DO NOT SCALE

USE MATH DATA

NX

APERTIV

CONNECTION SYSTEMS

Anting, China

COPYRIGHT 2022 APERTIV. ALL RIGHTS RESERVED.

THIS DRAWING IS THE PROPERTY OF APERTIV AND CONTAINS APERTIV CONFIDENTIAL INFORMATION. THE REPRODUCTION, DISTRIBUTION AND UTILIZATION OF THIS DOCUMENT OR ITS RELATED CAD MATH DATA, AS WELL AS COMMUNICATION OF ANY CONTENT TO OTHERS, WITHOUT EXPRESS AUTHORIZATION, IS PROHIBITED.

DR: YAN.DONGDONG
APVD1: MA.ARTHUR
APVD2: GAO.LINK
APVD3: GAO.LINK
APVD4: GAO.LINK
APVD5: GAO.LINK

DATE: 13JA22

UNLESS OTHERWISE SPECIFIED THIS DOCUMENT IS IN ACCORDANCE WITH ASME Y14.5-2009. SEE DELPHI ENGINEERING DESIGN STANDARD B6 2017 FOR ISO 1101:2004 RECONCILIATION REQUIREMENTS.

ALL DIMENSIONS ARE IN MILLIMETERS

THIRD ANGLE PROJECTION

DO NOT SCALE

USE MATH DATA

NX

DRAWING NAME: TAXI ASM LOCK RETAINER SEAL

DRAWING NUMBER: 35093966

SIZE: A1
SCALE: 2:1
FRAME NO: 1 OF 1
SHEET NO: 1 OF 1
STG: R
REV: 01