

SCALE 1:5

DIRECTION OF TERMINAL WINDING ON REEL AFTER GREASE

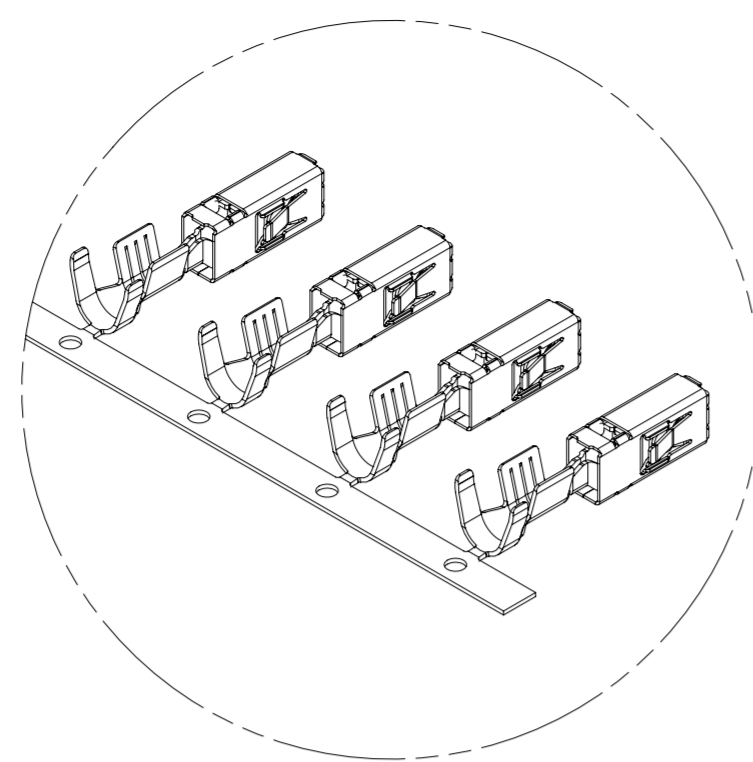

DETAIL D
SCALE 2:1

SYMBOL DEFINITION		TOTAL NO OF INSPECTIONS REQUIRED	
A DIMENSION WITHOUT AN INSPECTION REPORT SYMBOL DOES NOT REQUIRE INSPECTION. IT MAY BE CONTROLLED ON THE INDIVIDUAL COMPONENT DRAWING.		15	
	LAST NO. USED	6	

MISSING SYMBOLS					DWG STATUS			REVISION HISTORY			AUTH		DR		APVD		
NO MISSING SYMBOL NUMBER					DATE	STG	REV	N/P	CHG	ZONE	ALL PARTS - RELEASED PART DRAWING			437034	JGM	JGM	GVC
					03JL17	R	01	-	-		35082652-53 - UPDATED PART AVAILABILITY			443062	LVD	RBS	RBS

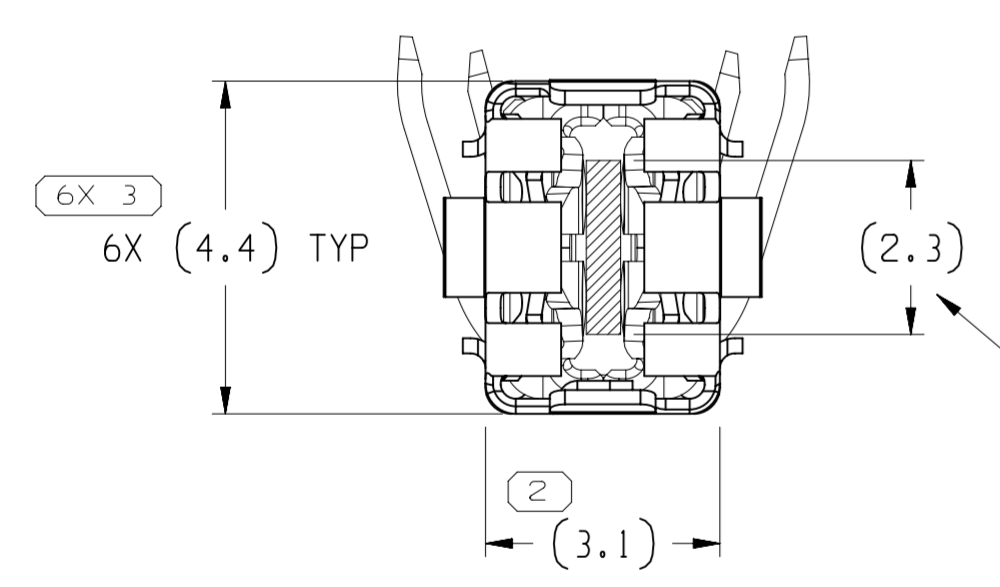
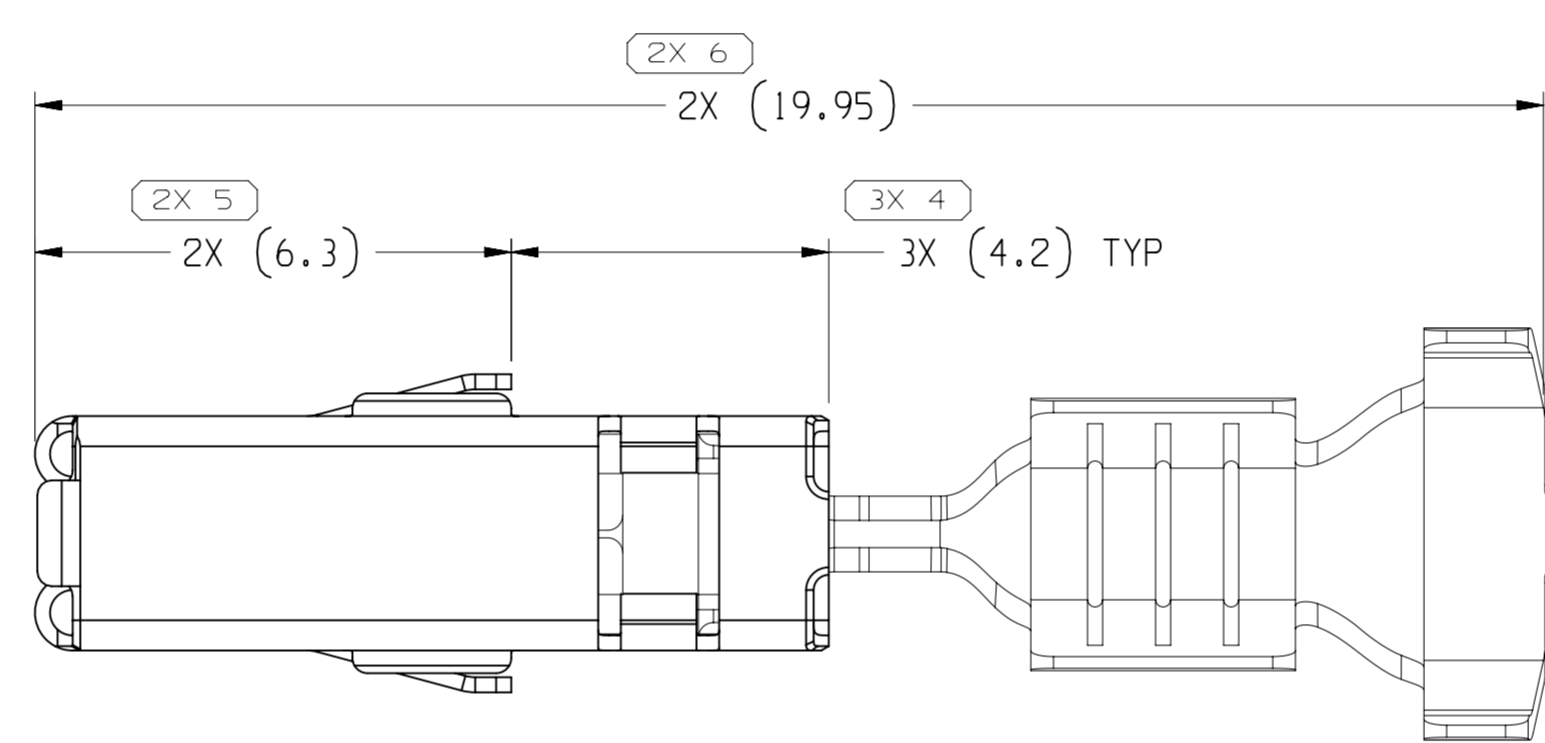
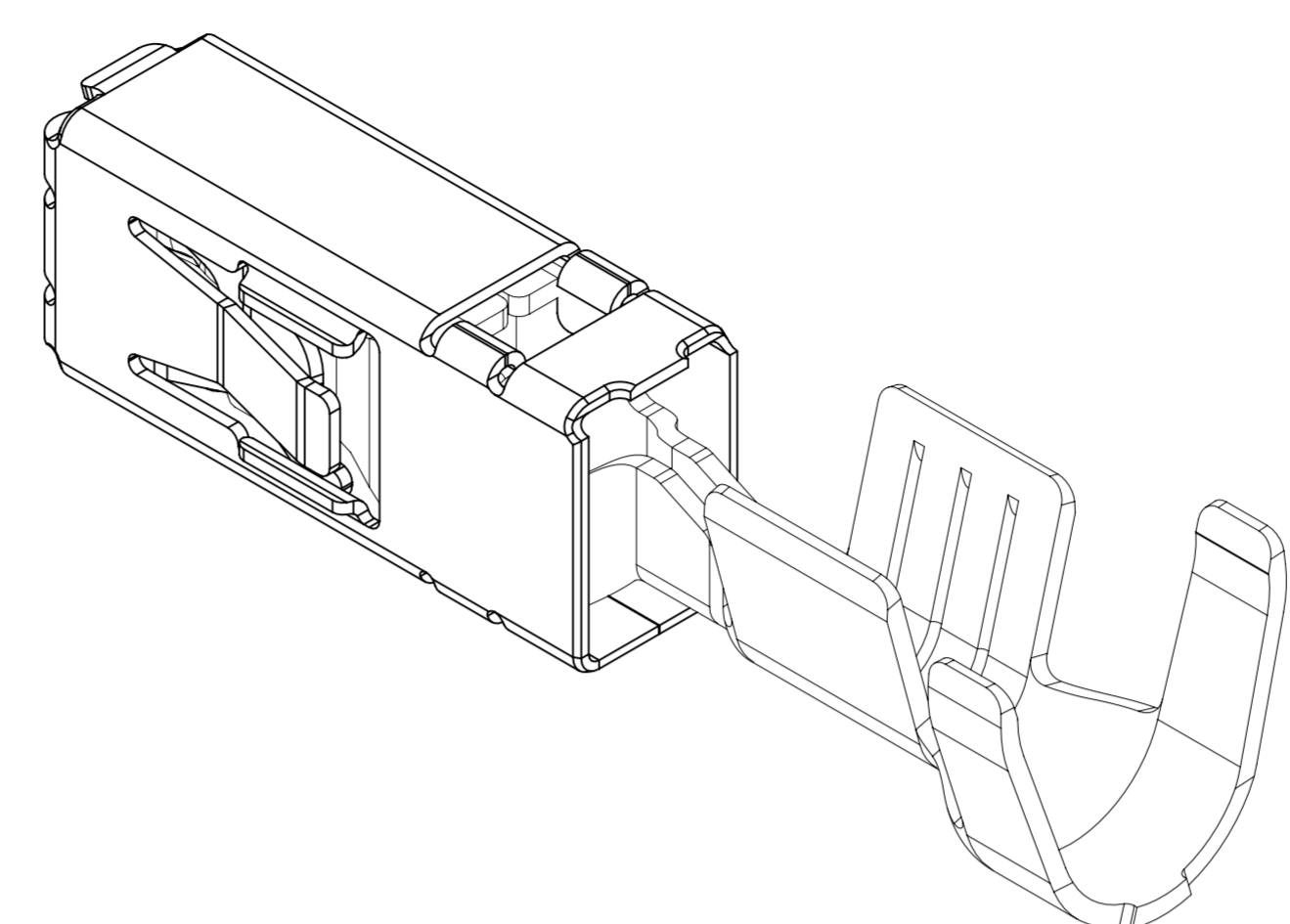

SEE NOTE #3 FOR REQUIRED GREASE COVERAGE.

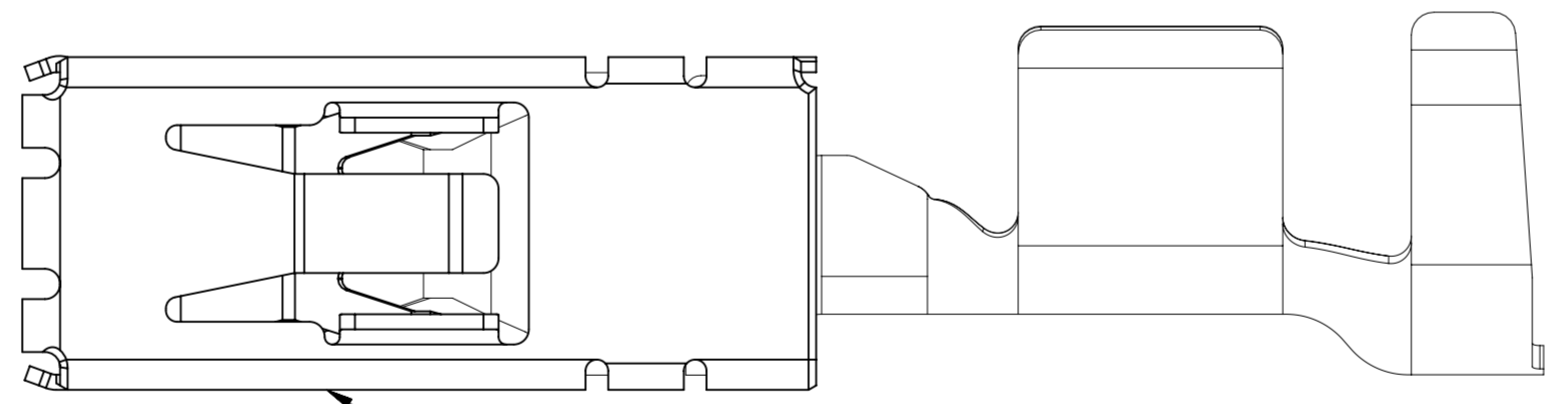

NOTES

- UNLESS OTHERWISE SPECIFIED AND/OR INDICATED:
DIMENSIONS ARE TO FACE OF VIEW SHOWN AND AUTOMATICALLY ROUNDED BY COMPUTER FOR INSPECTION (SEE MATH MODEL FOR PRECISE DIMENSIONS). FOR ALL OTHER DIMENSIONS NOT SHOWN BUT REQUIRED FOR TOOL BUILD, SEE MATH MODEL FOR PRECISE TOOL PATH DATA.
- REFERENCE BASE PN TAXI FOR ALL TERMINAL DETAILS AND DIMENSIONS.
- GREASE REQUIRED IN HATCHED AREA.

GREASE MUST TOUCH BOTH CONTACT BEAMS. GREASE COVERAGE SHOULD EXTEND BEYOND THE INSIDE EDGE OF THE OUTER NOSE PROTECTORS AS SHOWN.

MINIMAL GREASE ON OUTSIDE OF TERMINAL AND/OR IN TRANSITION AREA OR WINGS IS PERMISSIBLE, BUT SHOULD BE AVOIDED.

35082654	01	-	M5797004	13799598
35082653	01	AA	M5797004	13799600
35082652	01	AA	M5797004	13799602
PART NO	REV	N/P	GREASE MAT'L SPEC	ASM TERMINAL BASE P/N

PROCESS SENSITIVE DIMENSION	
DIMENSIONS ENCLOSED IN () INDICATE REFERENCE DIMENSIONS AND NO TOLERANCE LIMITS ARE ESTABLISHED	
DIMENSIONAL RANGE (MM)	CHART ID
FROM 0 TO 12	> 12
TOLERANCE UNLESS OTHERWISE SPECIFIED	
+0.1	+0.2
ANGULAR TOLERANCE	+2°

A LINE DRAWN THROUGH A PART NUMBER INDICATES THAT PHYSICAL PARTS ARE NOT AVAILABLE FOR ORDERING.	
PART NUMBERS THAT DO NOT HAVE A LINE PRESENT INDICATE THAT PHYSICAL PARTS ARE AVAILABLE FOR ORDERING.	
CONTACT APTIV SALES TO ASSURE AVAILABILITY OF PARTS.	
DWG TYPE: PART DRAWING	
STYLE	
VOLUME (CM)	DISTR CODE: D
UNLESS OTHERWISE SPECIFIED THIS DOCUMENT IS IN ACCORDANCE WITH ASME Y14.5M-1994 AS AMENDED BY THE GM GLOBAL DIMENSIONING AND TOLERANCING ADDENDUM-2001. SEPARATE PATTERNS OF FEATURES MAY BE GAGED SEPARATELY REGARDLESS OF DATUM REFERENCES.	
ALL DIMENSIONS ARE IN MILLIMETERS	
THIRD ANGLE PROJECTION	DO NOT SCALE
USE MATH DATA	

• APTIV •
CONNECTION SYSTEMS
WARREN, OH
COPYRIGHT 2017 APTIV. ALL RIGHTS RESERVED.

THIS DRAWING IS THE PROPERTY OF APTIV AND CONTAINS APTIV CONFIDENTIAL INFORMATION. THE REPRODUCTION, DISTRIBUTION AND UTILIZATION OF THIS DOCUMENT OR ITS RELATED CAD MATH DATA, AS WELL AS COMMUNICATION OF ANY CONTENT TO OTHERS, WITHOUT EXPRESS AUTHORIZATION, IS PROHIBITED.

DR	DATE
APVD1 JESSICA GARCIA M.	03JL17
APVD2 JESSICA GARCIA M.	03JL17
APVD3 GREG V. CHURLEY	06JL17
APVD4	
APVD5	

SUBSTANCES OF CONCERN AND RECYCLED CONTENT PER APTIV 10949001

MATERIAL: SEE CHART

DRAWING NAME: TAXI TERM F CTS 280 AG SEALED

DRAWING NUMBER: 35103550

SIZE	SCALE	FRAME NO	SHEET NO	STG	REV	N/P
A1	10:1	1 OF 1	1 OF 1	R	02	-