

SYMBOL DEFINITION		TOTAL NO OF INSPECTIONS REQUIRED	MISSING SYMBOLS
A DIMENSION WITHOUT AN INSPECTION REPORT SYMBOL DOES NOT REQUIRE INSPECTION. IT MAY BE CONTROLLED ON THE INDIVIDUAL COMPONENT DRAWING.		170	NO MISSING SYMBOL NUMBER
		15	

DATE	STG	REV	N/P	CHG	ZONE	REVISION HISTORY	AUTH	DR	APVD	APVD
010C20	R	01	-	-		35240525 - WAS SEPARATE DRAWING; 35496966 - RELEASED	552628	CDD	CDD	JSM
09AU22	R	02	-	-		35496966 - DIM 14 WAS 10.4 ± 0.15 AND UPDATED PART AVAILABILITY	558266	DCH	DCH	ACG

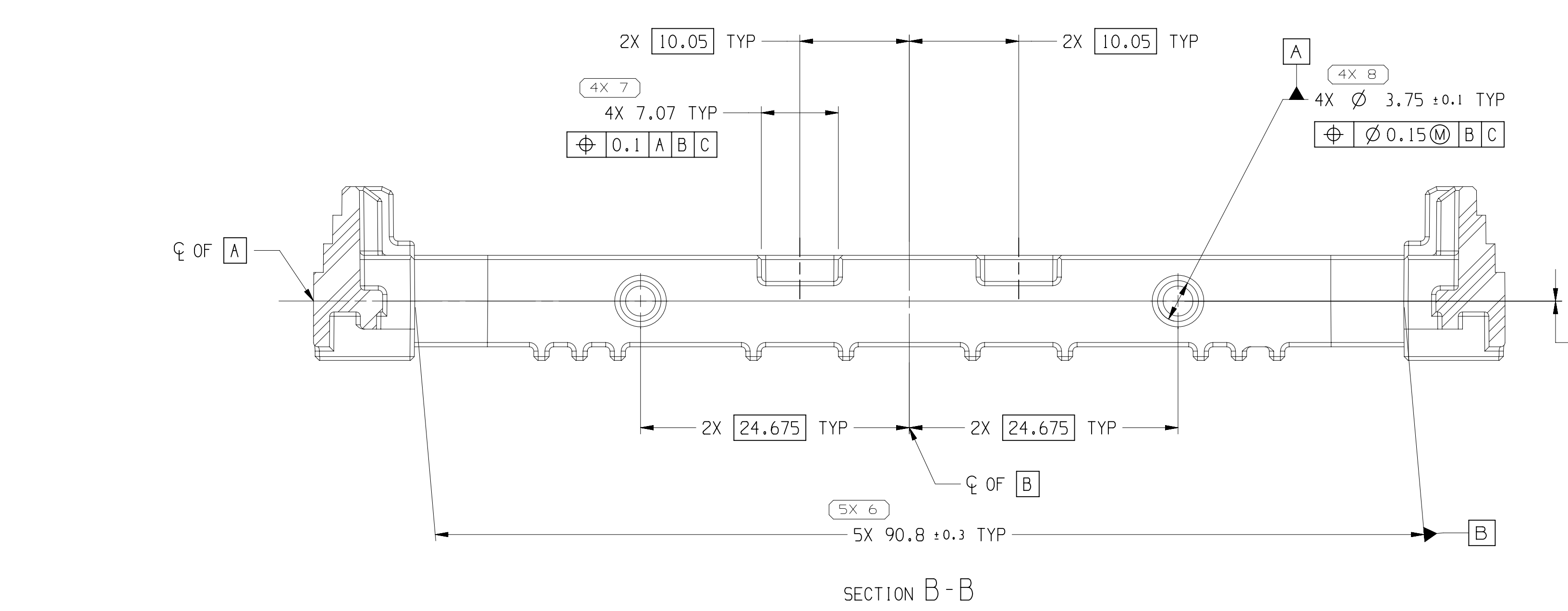
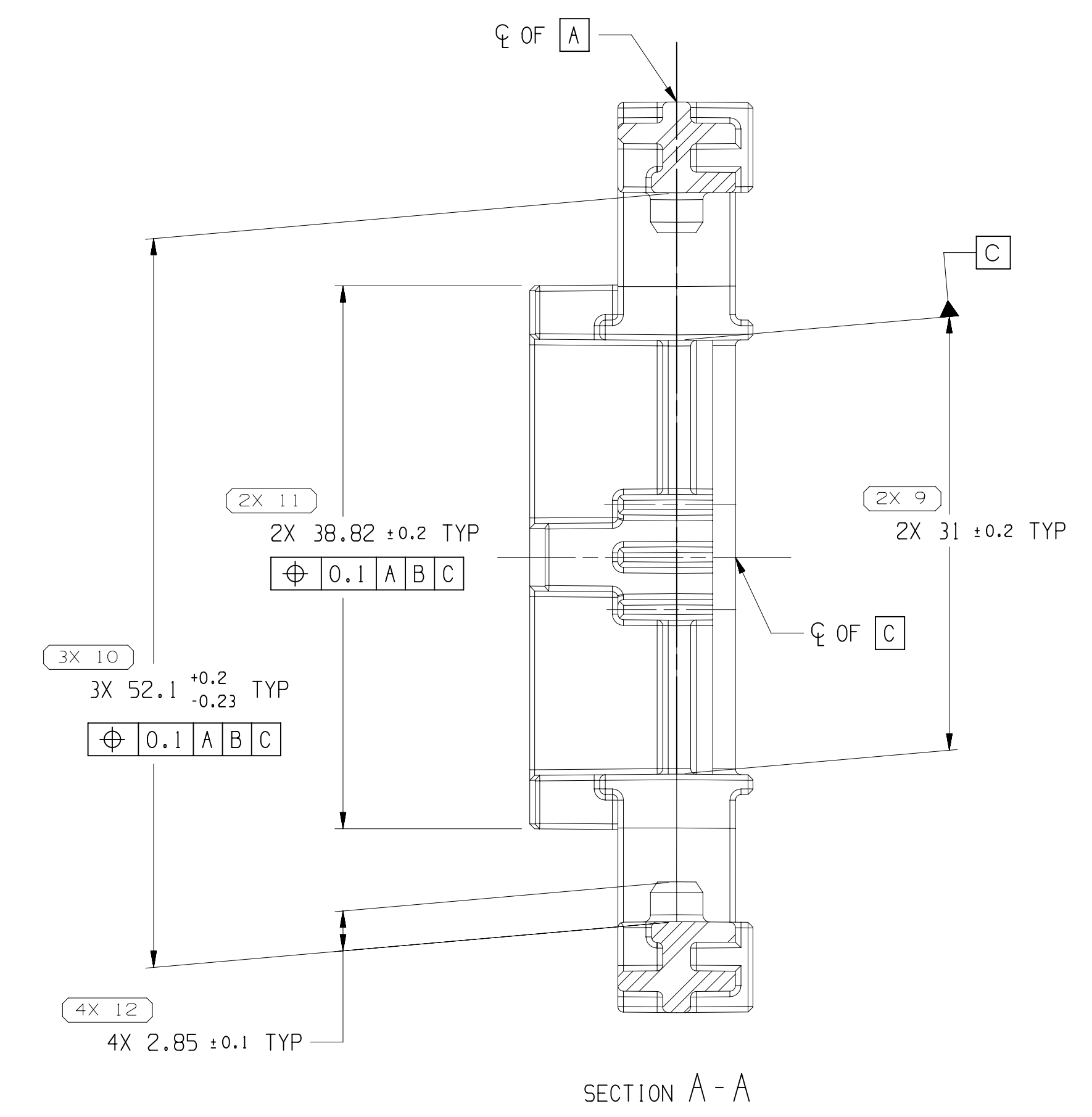
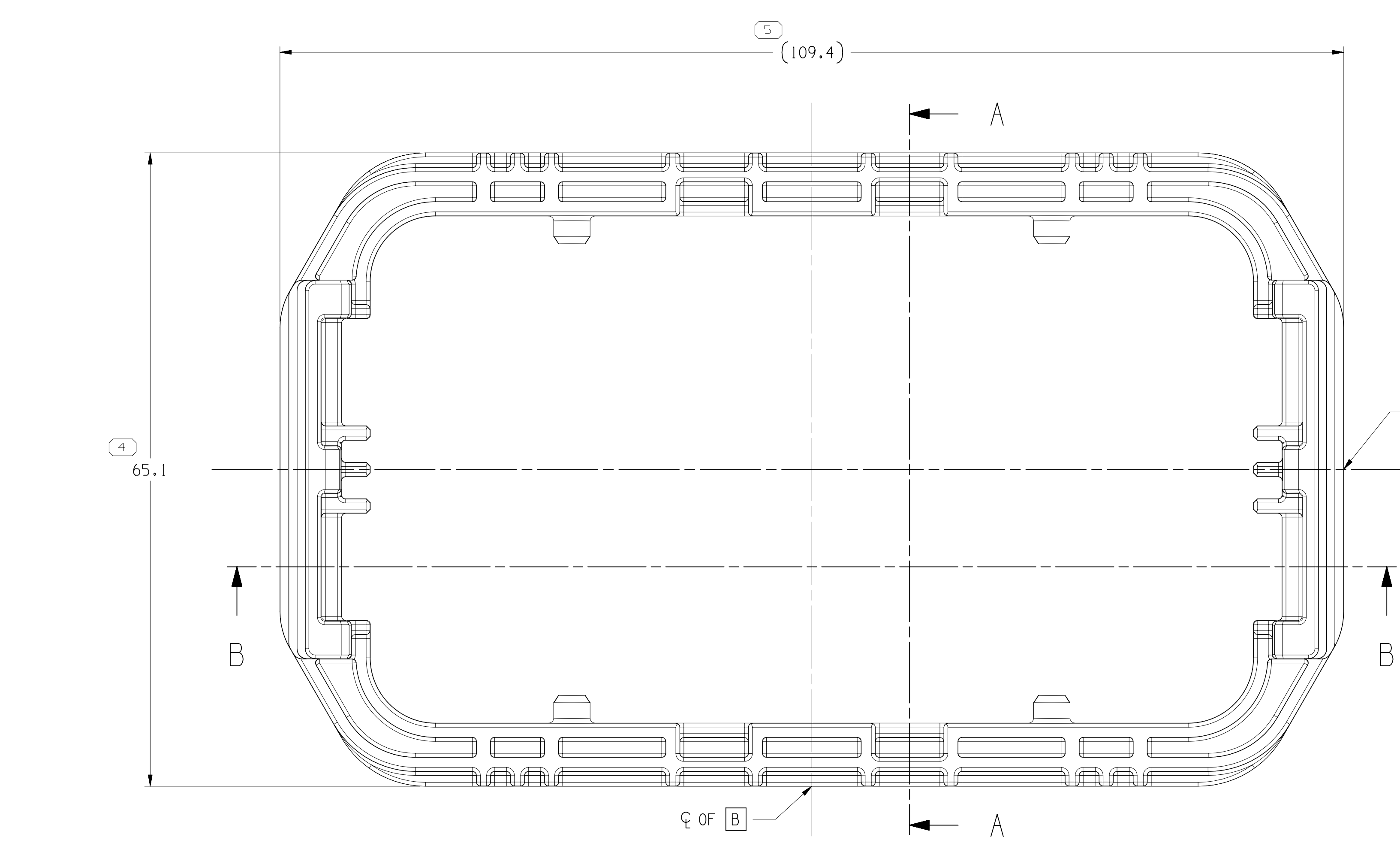
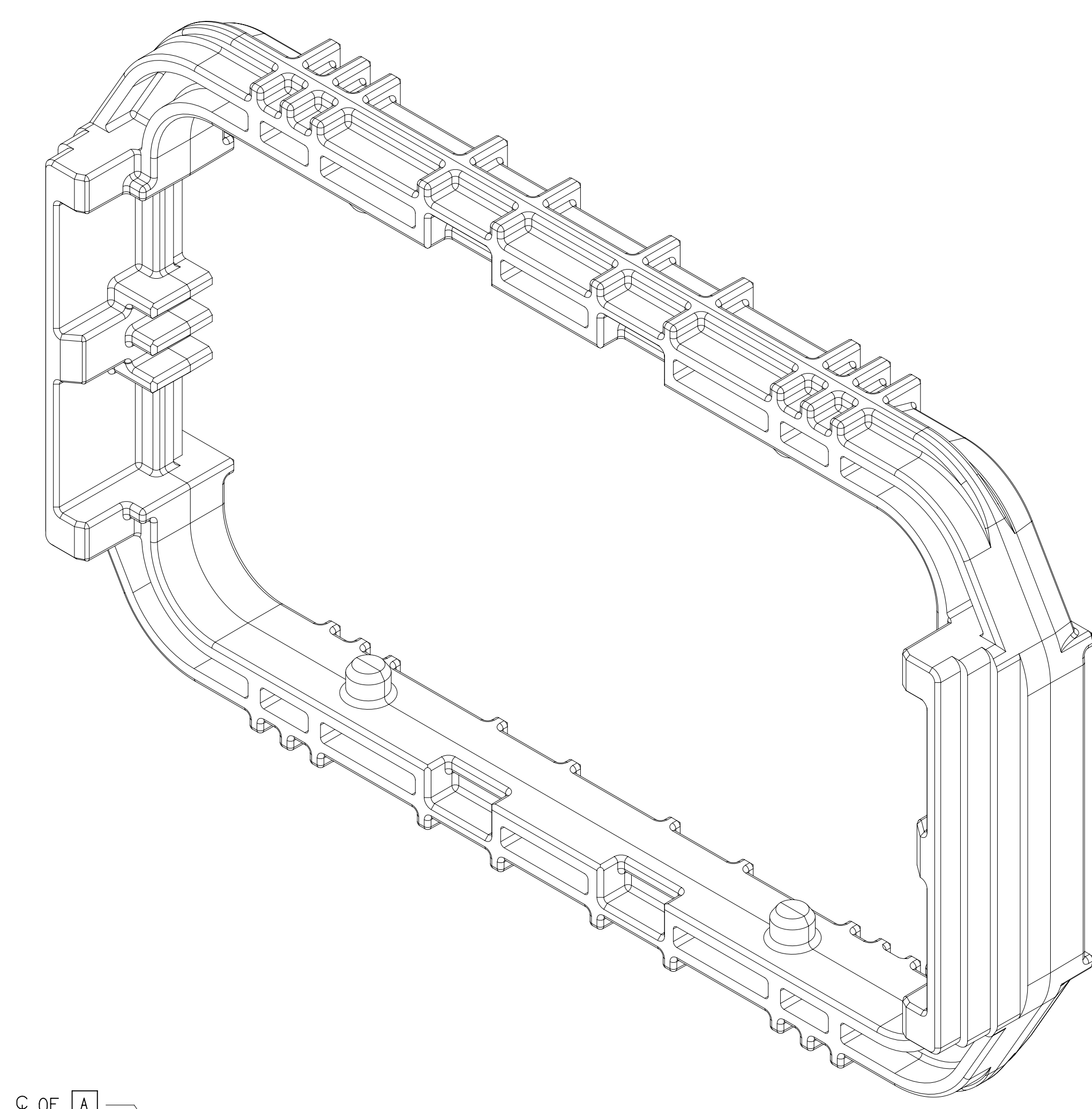
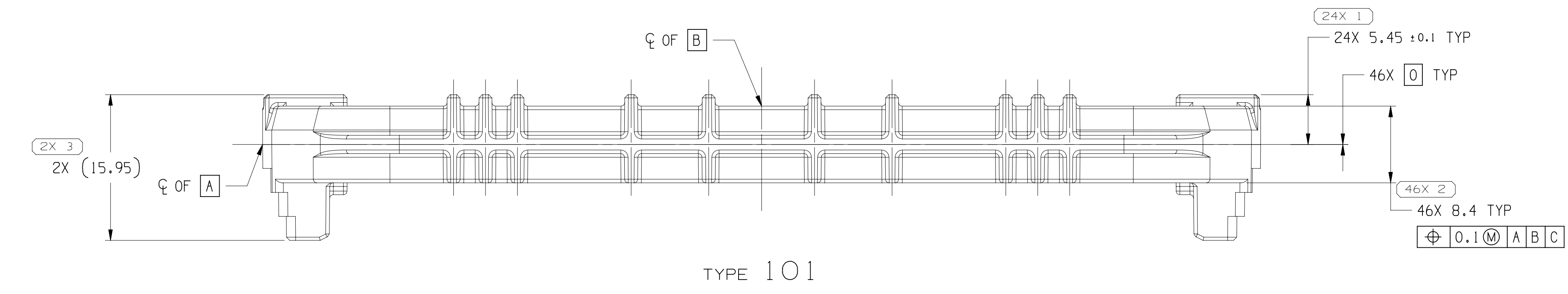
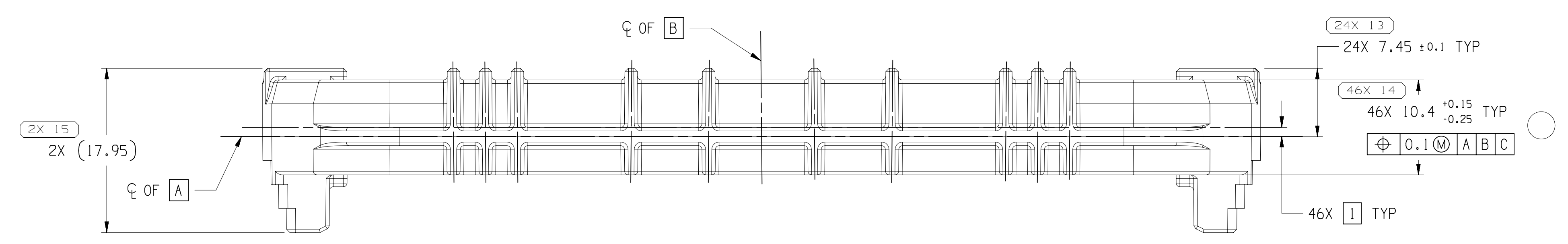

- NOTES
- UNLESS OTHERWISE SPECIFIED AND/OR INDICATED:
DIMENSIONS ARE TO FACE OF VIEW SHOWN AND AUTOMATICALLY ROUNDED BY COMPUTER FOR INSPECTION (SEE MATH MODEL FOR PRECISE DIMENSIONS). FOR ALL OTHER DIMENSIONS NOT SHOWN BUT REQUIRED FOR TOOL BUILD, SEE MATH MODEL FOR PRECISE TOOL PATH DATA.
 - MATERIAL RECYCLING CODE PER ISO 11469. (11)X(10.11) CHARACTERS AS SHOWN TO BE LOCATED ON ANY EXTERIOR SURFACE.
 - THIS PRODUCT IS NOT CATEGORIZED AS AN APPEARANCE ITEM, MINOR IMPERFECTIONS INCLUDING, BUT NOT LIMITED TO, FLOW MARKS, COLOR BLEMISHES, GATE VESTIGE, AND SOFT FLASH THAT DO NOT AFFECT THE FIT, FORM, OR FUNCTION OF THE PART ARE PERMISSIBLE PER EAMP-4-3-CS-01-EN.
 - CORPORATE BRAND TO BE APPLIED TO PRODUCT DESIGN PER THE LATEST REVISION OF ESD 51085201.
 - REFERENCE MATING COMPONENTS OR EQUIVALENT:
TAXI ASM CONN 35240508

DATE	STG	REV	N/P	CHG	ZONE	REVISION HISTORY	AUTH	DR	APVD	APVD
010C20	R	01	-	-		35240525 - WAS SEPARATE DRAWING; 35496966 - RELEASED	552628	CDD	CDD	JSM
09AU22	R	02	-	-		35496966 - DIM 14 WAS 10.4 ± 0.15 AND UPDATED PART AVAILABILITY	558266	DCH	DCH	ACG

APTIV
CONNECTION SYSTEMS
WARREN, OH
COPYRIGHT 2020 APTIV. ALL RIGHTS RESERVED.
THIS DRAWING IS THE PROPERTY OF APTIV AND CONTAINS APTIV CONFIDENTIAL INFORMATION. THE REPRODUCTION, DISTRIBUTION AND UTILIZATION OF THIS DOCUMENT OR ITS RELATED CAD DATA, AS WELL AS COMMUNICATION OF ANY CONTENT TO OTHERS, WITHOUT EXPRESS AUTHORIZATION, IS PROHIBITED.

DR	DATE
APVD1 CARLOS DELGADILLO	010C20
APVD2 CARLOS DELGADILLO	010C20
APVD3 J. SIFUENTES	010C20
APVD4	
APVD5	

SUBSTANCES OF CONCERN AND RECYCLED CONTENT PER APTIV 10949001

MATERIAL SEC CHART

DRAWING NAME: TAXI LOCK TPA/CLIP

DRAWING NUMBER: 35496966

SIZE: A0
SCALE: 3:1
FRAME NO: 1 OF 1
SHEET NO: 1 OF 1
STG REV N/P: R 02

PART NO	REV	N/P	TYPE	MATERIAL SPECIFICATION AND COLOR	VOLUME (CM ³)
35485589	01	AA	102	POLYAMIDE COMPOUND GREEN	14.192
35240525	01	AD	101	POLYAMIDE COMPOUND RED	12.415

DIMENSIONAL RANGE (MM)	CHART	ET
FROM > 0	> 20	> 30
TO > 20	> 30	> 40
> 30	> 40	> 50
> 40	> 50	> 60
> 50	> 60	> 70
> 60	> 70	> 80
> 70	> 80	> 90
> 80	> 90	> 100
> 90	> 100	> 110
> 100	> 110	> 120
> 110	> 120	> 130
> 120	> 130	> 140
> 130	> 140	> 150
> 140	> 150	> 160
> 150	> 160	> 170
> 160	> 170	> 180
> 170	> 180	> 190
> 180	> 190	> 200
> 190	> 200	> 210
> 200	> 210	> 220
> 210	> 220	> 230
> 220	> 230	> 240
> 230	> 240	> 250
> 240	> 250	> 260
> 250	> 260	> 270
> 260	> 270	> 280
> 270	> 280	> 290
> 280	> 290	> 300
> 290	> 300	> 310
> 300	> 310	> 320
> 310	> 320	> 330
> 320	> 330	> 340
> 330	> 340	> 350
> 340	> 350	> 360
> 350	> 360	> 370
> 360	> 370	> 380
> 370	> 380	> 390
> 380	> 390	> 400

4 PROCESS SENSITIVE DIMENSION

UNLESS OTHERWISE SPECIFIED

ALL DIMENSIONS ARE IN MILLIMETERS

THIRD ANGLE PROJECTION

DO NOT SCALE USE MATH DATA

NX