

DETAIL DOIGTS
DE DESHUNTING
UNSHUNTING FINGER
DETAIL

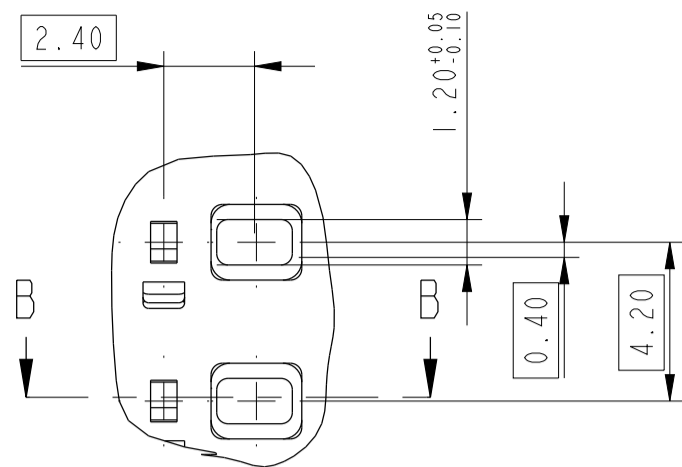

SECTION B-B
SCALE 5 : 1

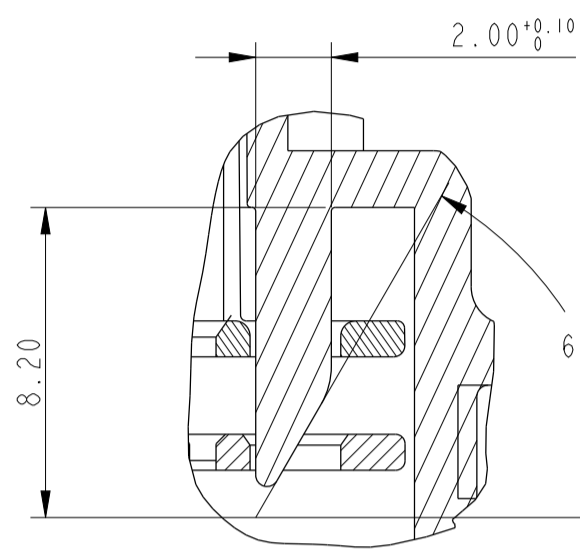

DATEUR (MOIS / ANNEE)
DATE INDICATOR (MONTH / YEAR)

REPERE D'ALVEOLE
CAVITY POSITIONING

SIGLE MVL
LOGO MVL

MARQUAGE MATIERE
MATERIAL MARKING

REPERE EMPREINTE
MOULD CAVITY POSITIONING

INDICE MAJEUR DU PRODUIT FINI
MAJOR LEVEL OF THE ASSEMBLY

REFERENCE PRODUIT FINI
REFERENCE OF THE ASSEMBLY

IMPLANTATION DES ALVEOLES
CAVITIES LAY OUT

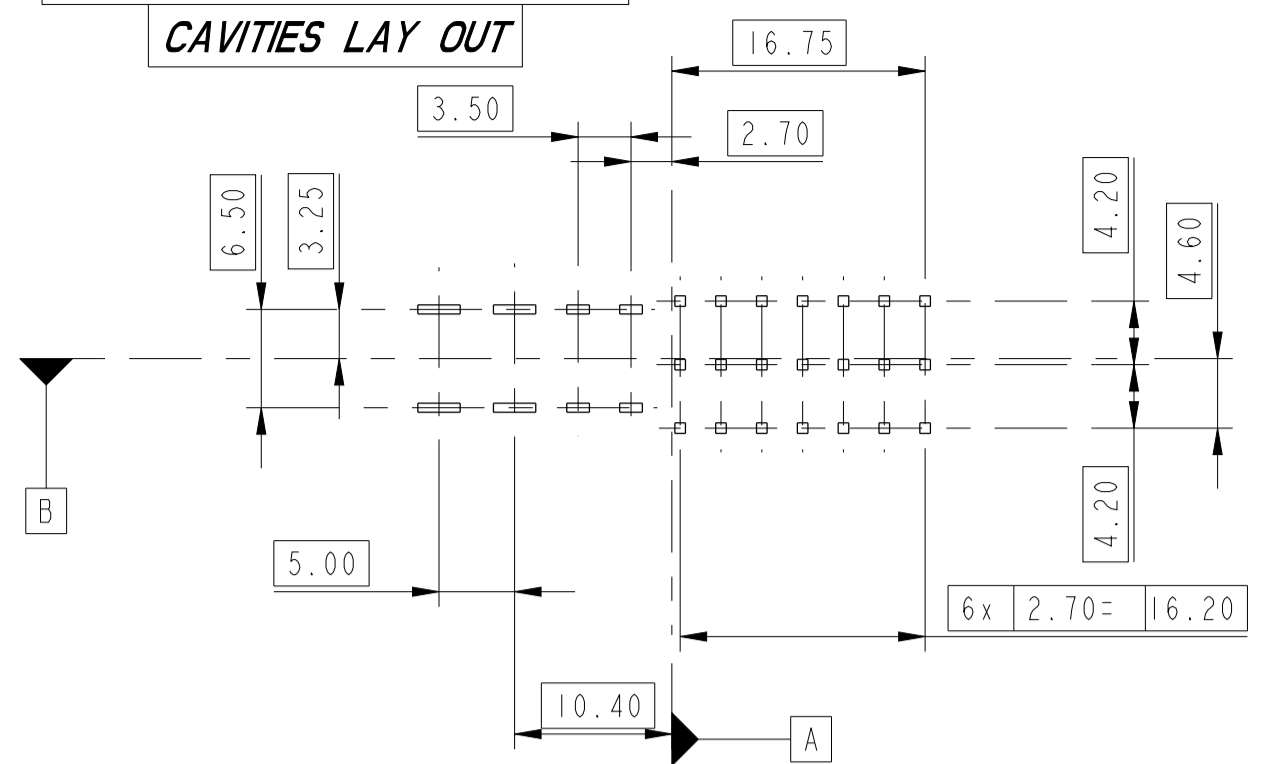

DECOUPE TOLE POUR LE PORTE-LANGUETTES
CARBODY HOLE FOR THE MALE CONNECTORS

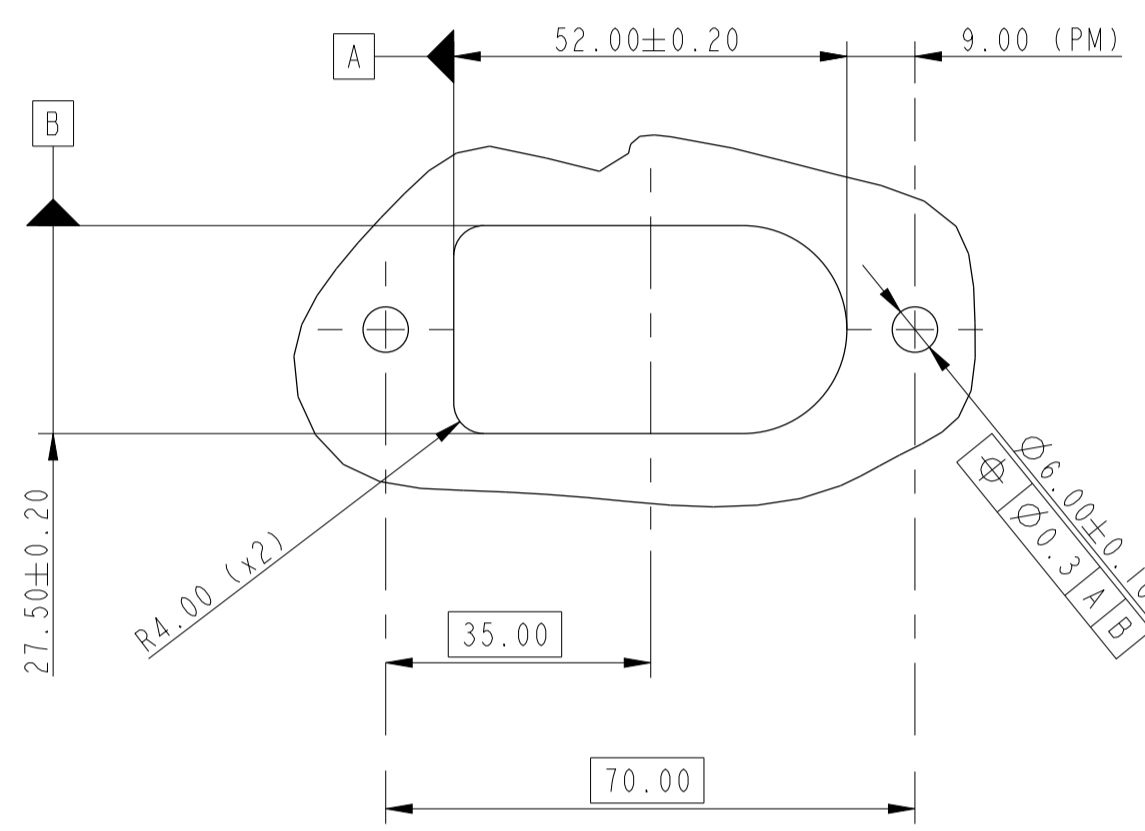

TOLE EPAISSEUR : 0.8 à 1.3
CARBODY HOLE : THICKNESS from 08 to 13

COUPE A-A

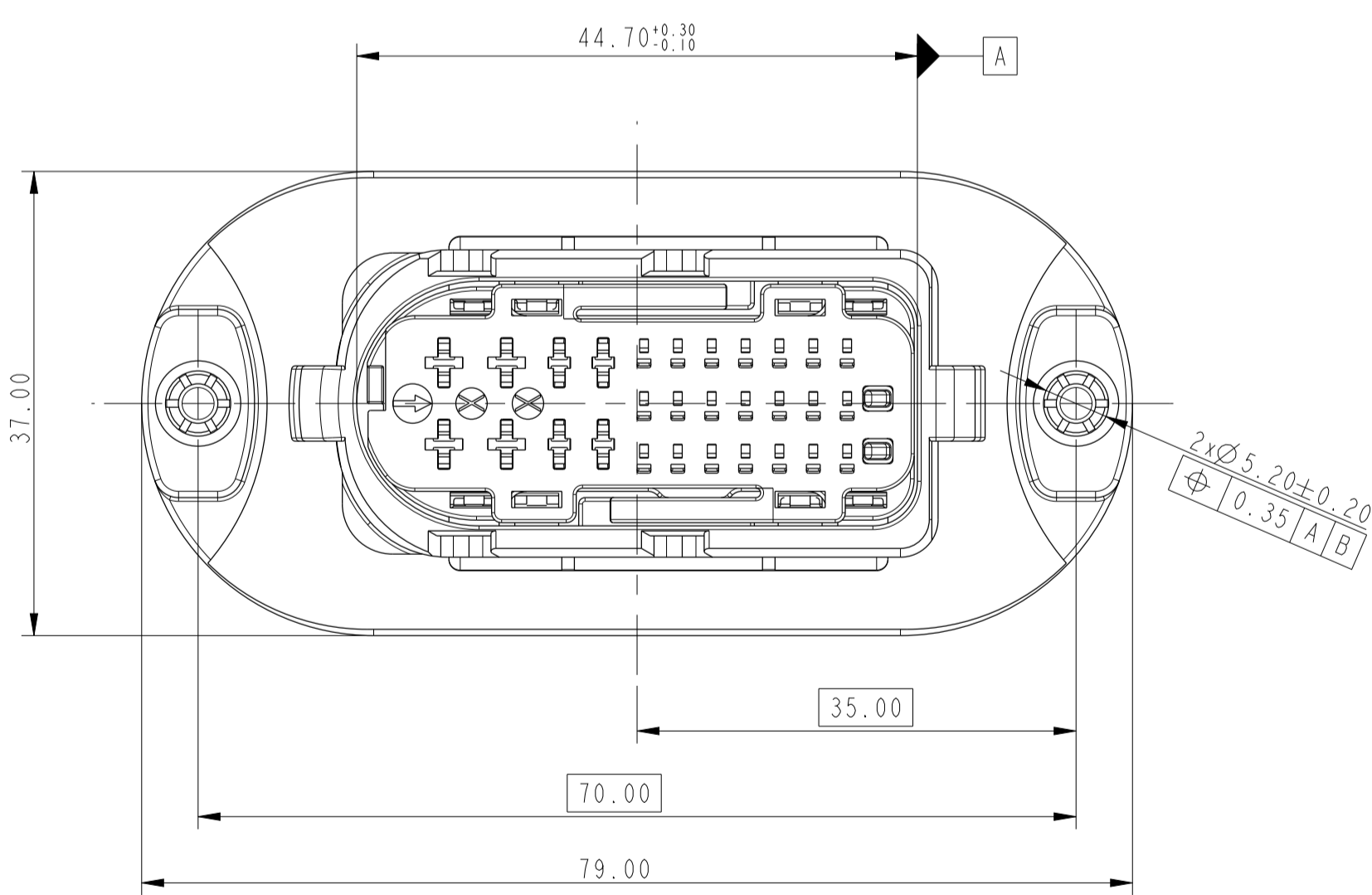
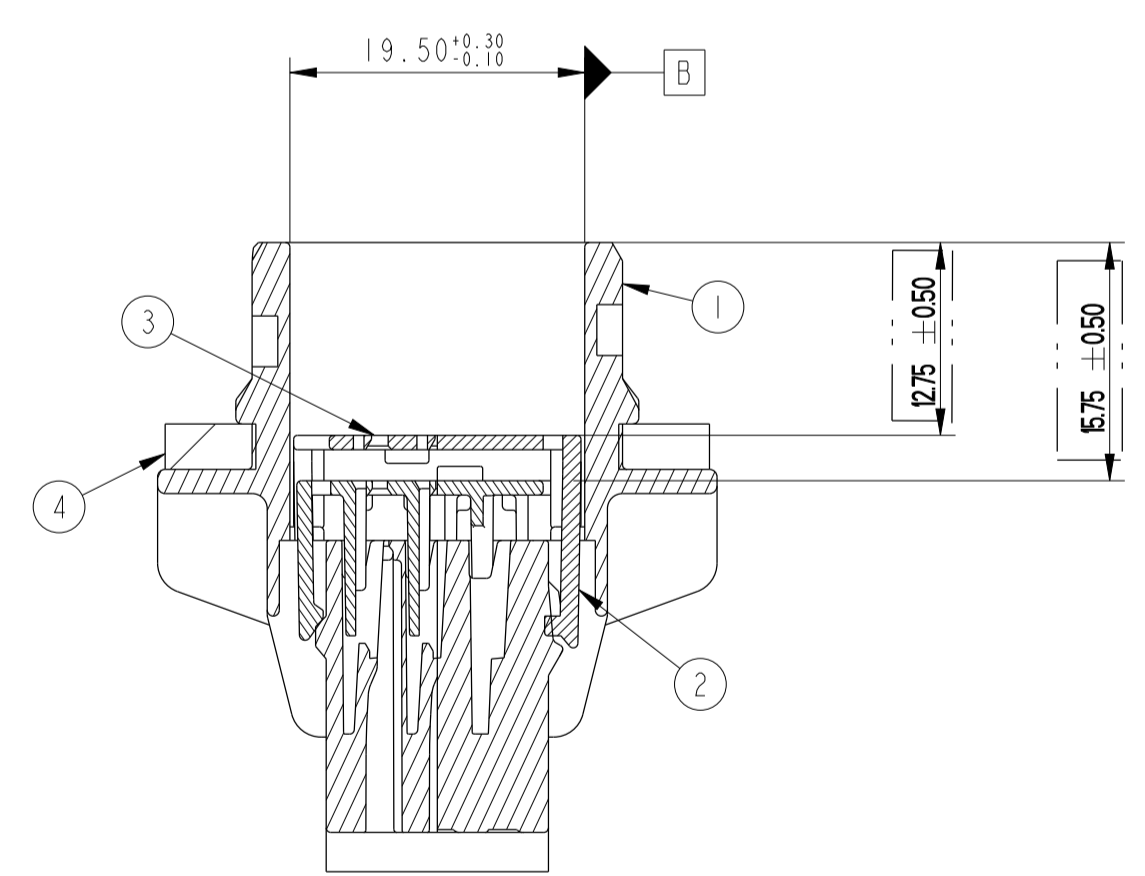
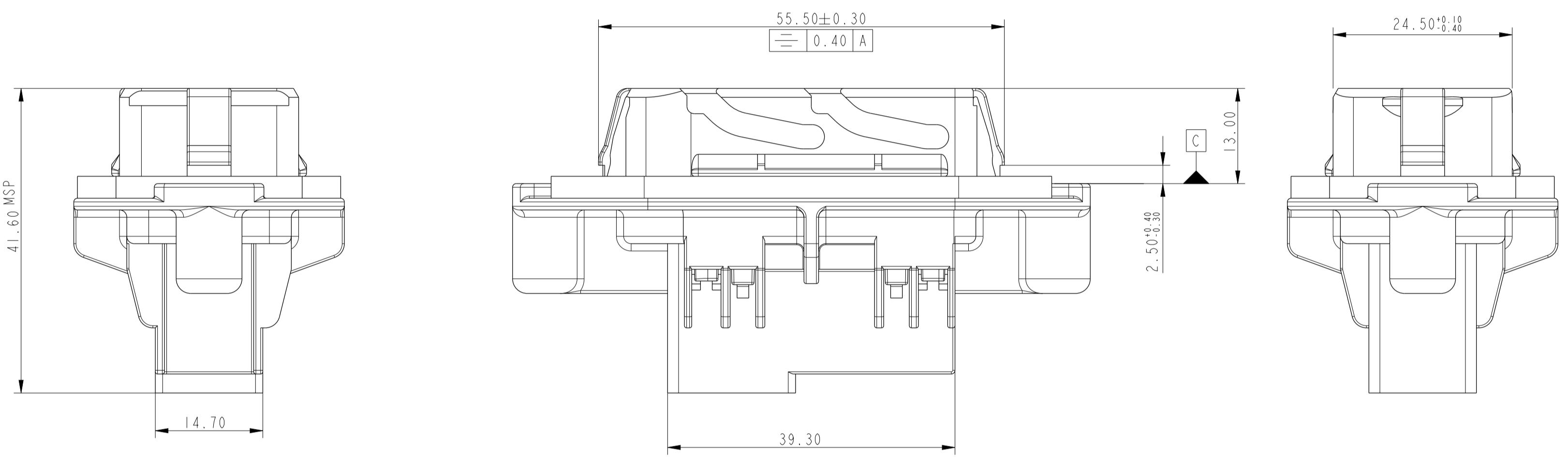

NOTA : LES COTES INDIQUEES EN GRAS ET ENCADREES
SONT DES COTES D'ASSEMBLAGE
**BOLD AND BOXED DIMENSIONS ARE ASSEMBLY
DIMENSIONS**

2,8 x 0,8 SICMA 3	1 à 2	211 CL 3 S XX60
2,8 x 0,8 SICMA 2	1 à 3	211 CL 3 S XX2X
1,5 x 0,8 SICMA 3	1 à 2	211 CL 2 S XX60
1,5 x 0,8 SICMA 2	1 à 2	211 CL 2 S XX2X
MICRO-SICMA 1 x 0.635	0 à 1	211 CL 1 S XX22
TYPE LANGUETTE MALE TERMINAL TYPE	GAMME RANGE	REFERENCE REFERENCE
LANGUETTES UTILISABLES AVAILABLE MALE TERMINALS		

4	JOINT TOLE FLAT SEAL	211 M 0107	ELASTOMERE ELASTOMER	NOIR BLACK
3	GRILLE DE PROTECTION PROTECTIVE GRID	211 M 8104	PBT GF 30	GRIS GREY
2	VERROU SECONDAIRE SECONDARY LOCKING	211 M 4105	PBT GF 30	JAUNE YELLOW
1	PORTE-LANGUETTES MALE CONNECTOR	211 I 0060	PBT GF 30	NOIR BLACK
Rep Item	DESIGNATION DESCRIPTION	REF. MVL	MATIERE MATERIAL	COULEUR COLOR
	RENAULT	PART NUMBER	8200 093 850	
	MVL	PART REVISION	211 PL 29 9 S 0 042	
	DELPHI	PART NUMBER	10811880	
		PART REVISION	01	

ECN-NO. NUMERO ECH	POSITION POSITION	CHANGE DESCRIPTION MODIFICATION
		DELPHI P/N ADDED
PROJET SPEC. SPECIF. PRODUIT	PAQUETAGE SPEC. SPECIF. ENSEMBLAGE	APPLICATION SPEC. SPECIF. APPLICATION
<p>DO NOT MEASURE DRAWING NE PAS MESURER LE DRESSING</p> <p>DO NOT MEASURE DRAWING NE PAS MESURER LE DRESSING</p>		
TOLERANCES TOLERANCES	±0.3	±2*
CONTRIBUTOR CONTRIBUTEUR	211PC299S004X	
DATE	NAME	TITLE
2008/2009	BLADON	PROJECT
2010/04/09	F FAURIE	PROJECT
2010/04/02	S LACOTE	PROJECT
2010/04/02	PROSCH MENARD	PROJECT
211FT0384		