

SYMBOL DEFINITION		MISSING SYMBOLS	
A DIMENSION WITHOUT AN INSPECTION REPORT SYMBOL  DOES NOT REQUIRE INSPECTION. IT MAY BE CONTROLLED ON THE INDIVIDUAL COMPONENT DRAWING.	TOTAL NO OF INSPECTIONS REQUIRED	NO MISSING SYMBOL NUMBER	13
	LAST NO. USED		5

DATE	STG	REV	N/P	CHG	ZONE	REVISION HISTORY	AUTH	DR	APVD1	APVD2
26NO19	R	01	-	-		35197158 WAS PE 388214; 35197159 WAS PE 388215; 35197160 WAS PE 404674; ALL PARTS - RELEASED PART DRAWING	550174	GLG	EVV	JER
27MR20	R	02	-	-		35406662 - WAS SEPARATE DRAWING; ALL PARTS - UPDATED MAT'L CALLOUT; 35197158-60 - UPDATED PART AVAILABILITY	551344	ORA	JER	JER
20JL21	R	03	-	-		35586484 - RELEASED	554829	GDH	EVV	RIV
19JA22	R	04	-	-		35197158-60 & 35406662 - UPDATED PART AVAILABILITY	556341	EZJ	JAA	LES

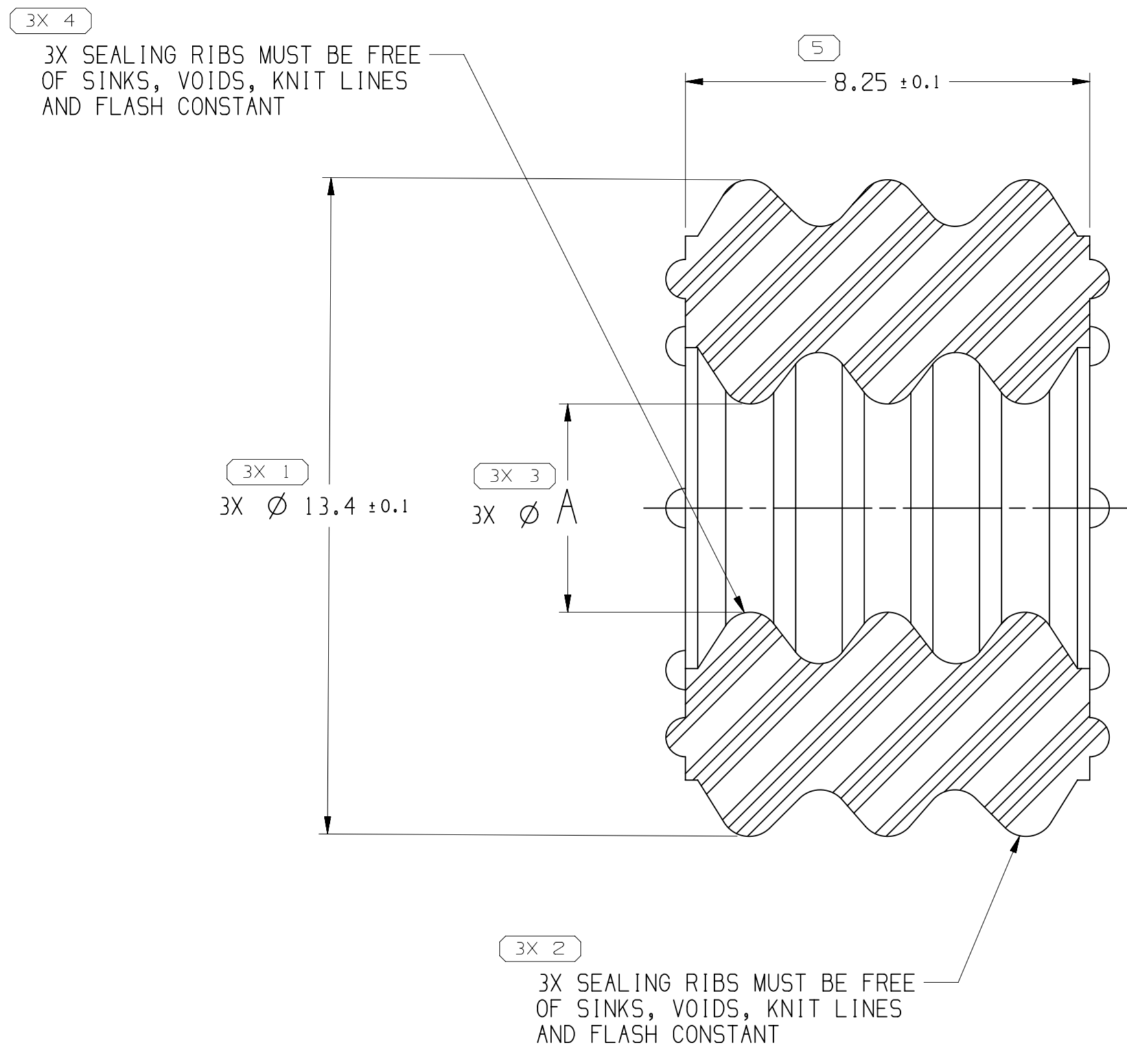
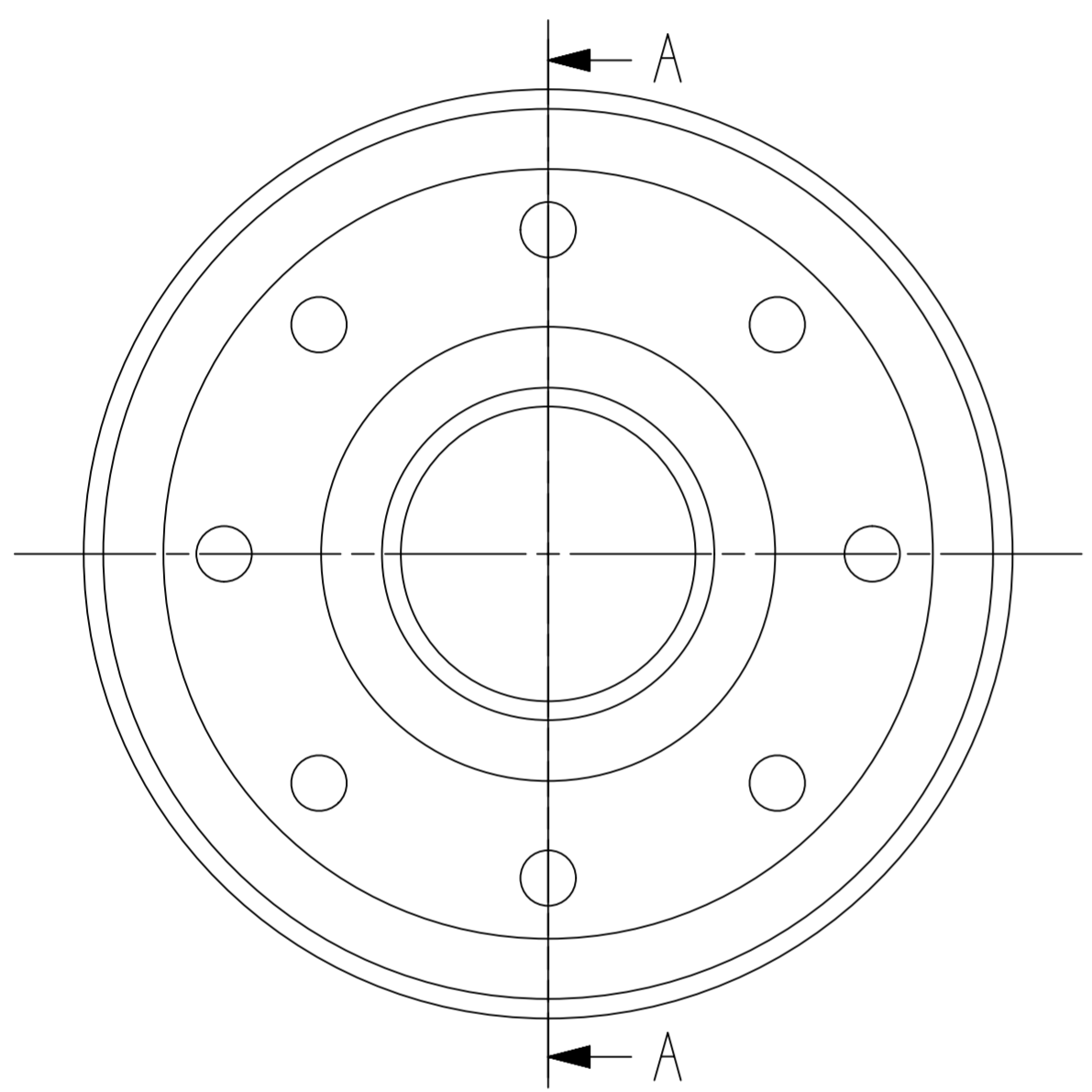
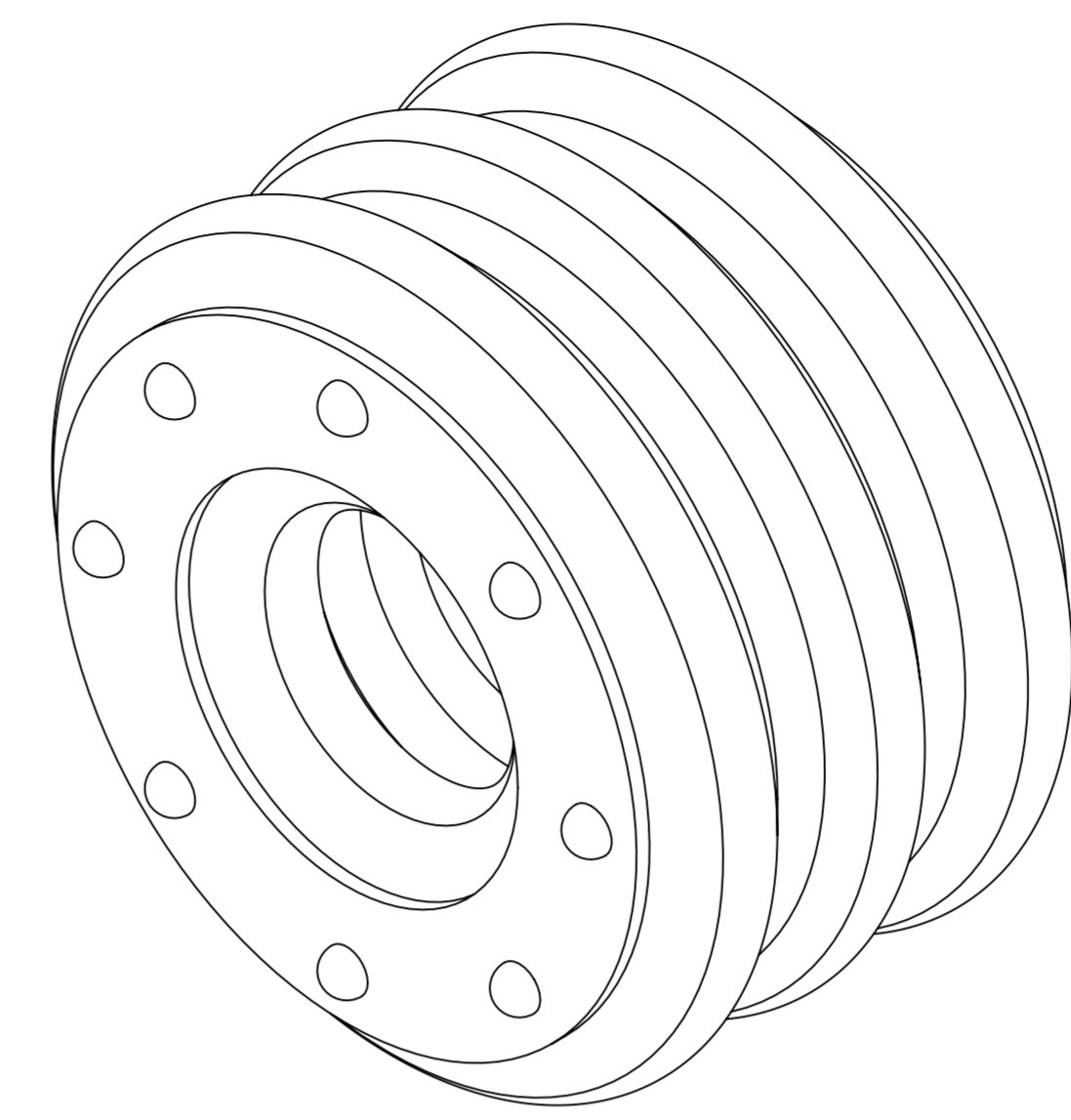

SECTION A - A

NOTES

- UNLESS OTHERWISE SPECIFIED AND/OR INDICATED:
DIMENSIONS ARE TO FACE OF VIEW SHOWN AND AUTOMATICALLY ROUNDED BY COMPUTER FOR INSPECTION (SEE MATH MODEL FOR PRECISE DIMENSIONS). FOR ALL OTHER DIMENSIONS NOT SHOWN BUT REQUIRED FOR TOOL BUILD, SEE MATH MODEL FOR PRECISE TOOL PATH DATA.
- THIS PRODUCT IS NOT CATEGORIZED AS AN APPEARANCE ITEM, MINOR IMPERFECTIONS INCLUDING, BUT NOT LIMITED TO, FLOW MARKS, COLOR BLEMISHES, GATE VESTIGE, AND SOFT FLASH THAT DO NOT AFFECT THE FIT, FORM, OR FUNCTION OF THE PART ARE PERMISSIBLE PER EANP_4-3_CS_01_EN.
- THIS PART ACCEPTS THE FOLLOWING COMPONENTS OR EQUIVALENT:
CONNECTOR ASSEMBLIES SHOWN ON TAXIS 35197133

PART NO	REV	N/P	MATERIAL SPECIFICATION AND COLOR	VOLUME (CM ³)	SIZE (MM ²)	O.D.	A ± 0.1
35586484	01	-	SILICONE METHYL/VINYL YELLOW	0.680	16	6.4-7.2	5.9
35406662	02	AA	SILICONE METHYL/VINYL WHITE	0.880	6	4.0 - 4.3	3.25
35197160	02	AA	SILICONE METHYL/VINYL GRAY	0.723	12	5.8 - 6.5	5.45
35197159	02	AA	SILICONE METHYL/VINYL GREEN	0.763	10	5.3 - 6.0	4.95
35197158	02	AA	SILICONE METHYL/VINYL BLUE	0.815	8	4.6 - 5.0	4.25

DIMENSIONAL RANGE (MM)	CHART	ET
FROM > 0	> 20	> 300
TO 20	30	300
	70	100
	100	150
	150	200
	200	250
	250	300
	300	400

TOLERANCE UNLESS OTHERWISE SPECIFIED

±0.15	±0.2	±0.3	±0.4	±0.5	±0.6	±0.8	±1	±1.2
-------	------	------	------	------	------	------	----	------

ANGULAR TOLERANCE ±2°

LINE DRAWN THROUGH A PART NUMBER INDICATES THAT PHYSICAL PARTS ARE NOT AVAILABLE FOR ORDERING.

PART NUMBERS THAT DO NOT HAVE A LINE PRESENT INDICATE THAT PHYSICAL PARTS ARE AVAILABLE FOR ORDERING.

CONTACT APTIV SALES TO ASSURE AVAILABILITY OF PARTS.

DWG TYPE: PART DRAWING

STYLE: D

VOLUME (CM³):

DISTR CODE: D

UNLESS OTHERWISE SPECIFIED

THIS DOCUMENT IS IN ACCORDANCE WITH ASME Y14.5M-1994 AS AMENDED BY THE GM GLOBAL DIMENSIONING AND TOLERANCING ADDENDUM-2001. SEPARATE PATTERNS OF FEATURES MAY BE GAGED SEPARATELY REGARDLESS OF DATUM REFERENCES.

ALL DIMENSIONS ARE IN MILLIMETERS

THIRD ANGLE PROJECTION

DO NOT SCALE

USE MATH DATA

NX

• APTIV •

CONNECTION SYSTEMS

WARREN, OH

COPYRIGHT 2019 APTIV. ALL RIGHTS RESERVED.

THIS DRAWING IS THE PROPERTY OF APTIV AND CONTAINS APTIV CONFIDENTIAL INFORMATION. THE REPRODUCTION, DISTRIBUTION AND UTILIZATION OF THIS DOCUMENT OR ITS RELATED CAD MATH DATA, AS WELL AS COMMUNICATION OF ANY CONTENT TO OTHERS, WITHOUT EXPRESS AUTHORIZATION, IS PROHIBITED.

DR	DATE
APVD1 G. LOPEZ G.	26NO19
APVD2 ELIAS VAZQUEZ V.	27NO19
APVD3 JOSE E. DIAZ	28NO19
APVD4	
APVD5	

SUBSTANCES OF CONCERN AND RECYCLED CONTENT PER APTIV 10949001

MATERIAL SEE CHART

DRAWING NAME: TAXI SEAL CBL IW

DRAWING NUMBER: 35197161

SIZE	SCALE	FRAME NO	SHEET NO	STG	REV	N/P
A1	10:1	1 OF 1	1 OF 1	R	04	-