

SYMBOL DEFINITION		TOTAL NO OF INSPECTIONS REQUIRED	MISSING SYMBOLS
A DIMENSION WITHOUT AN INSPECTION REPORT SYMBOL DOES NOT REQUIRE INSPECTION. IT MAY BE CONTROLLED ON THE INDIVIDUAL COMPONENT DRAWING.		5	NO MISSING SYMBOL NUMBER
		5	

DWG STATUS	DATE	STG	REV	APP	CHK	ZONE	REVISION HISTORY	AUTH	DR	APVD	APVD
	18AP22	R	01	-	-		CREATED PART DRAWING	447528	KAV	ZKH	ZJ

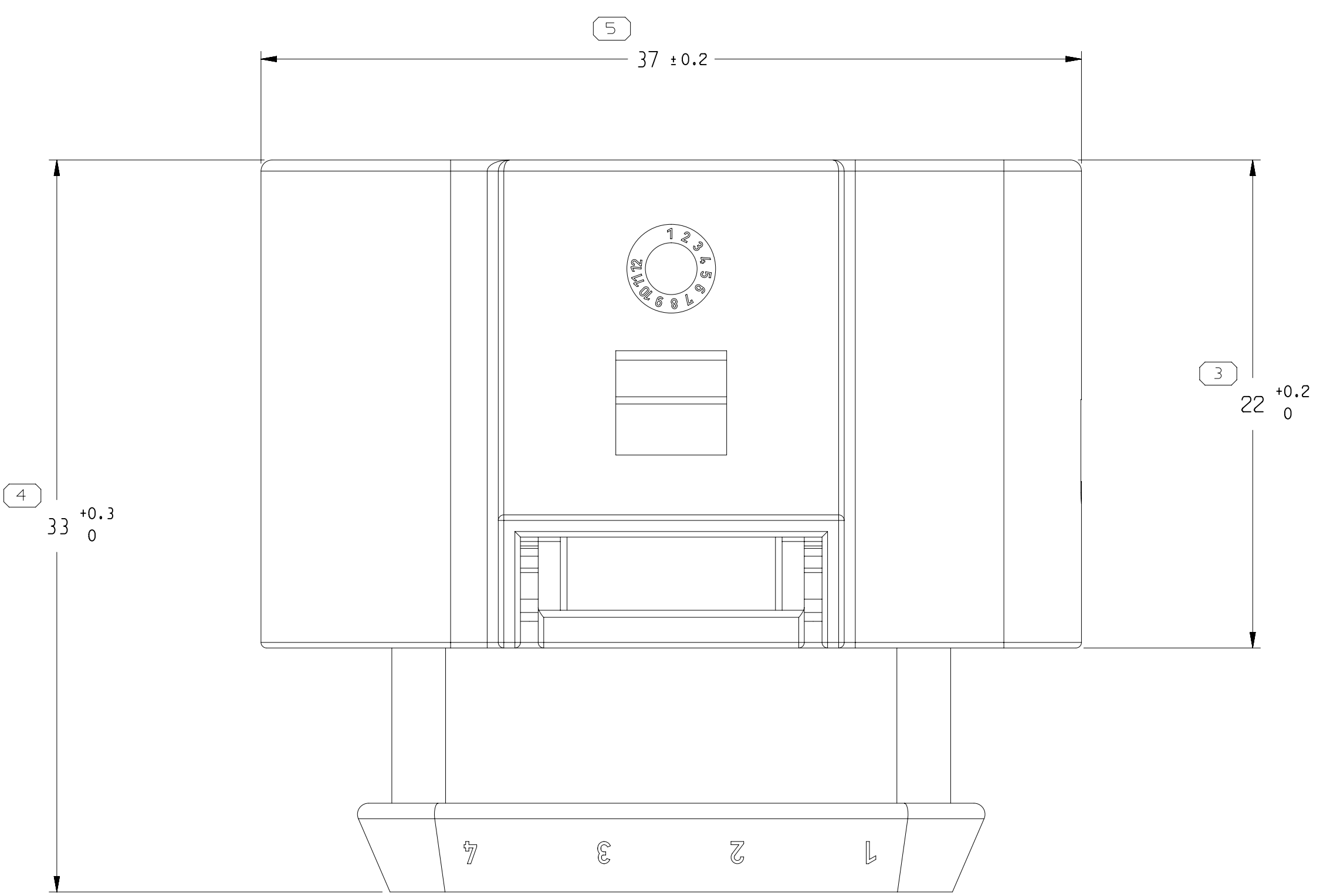
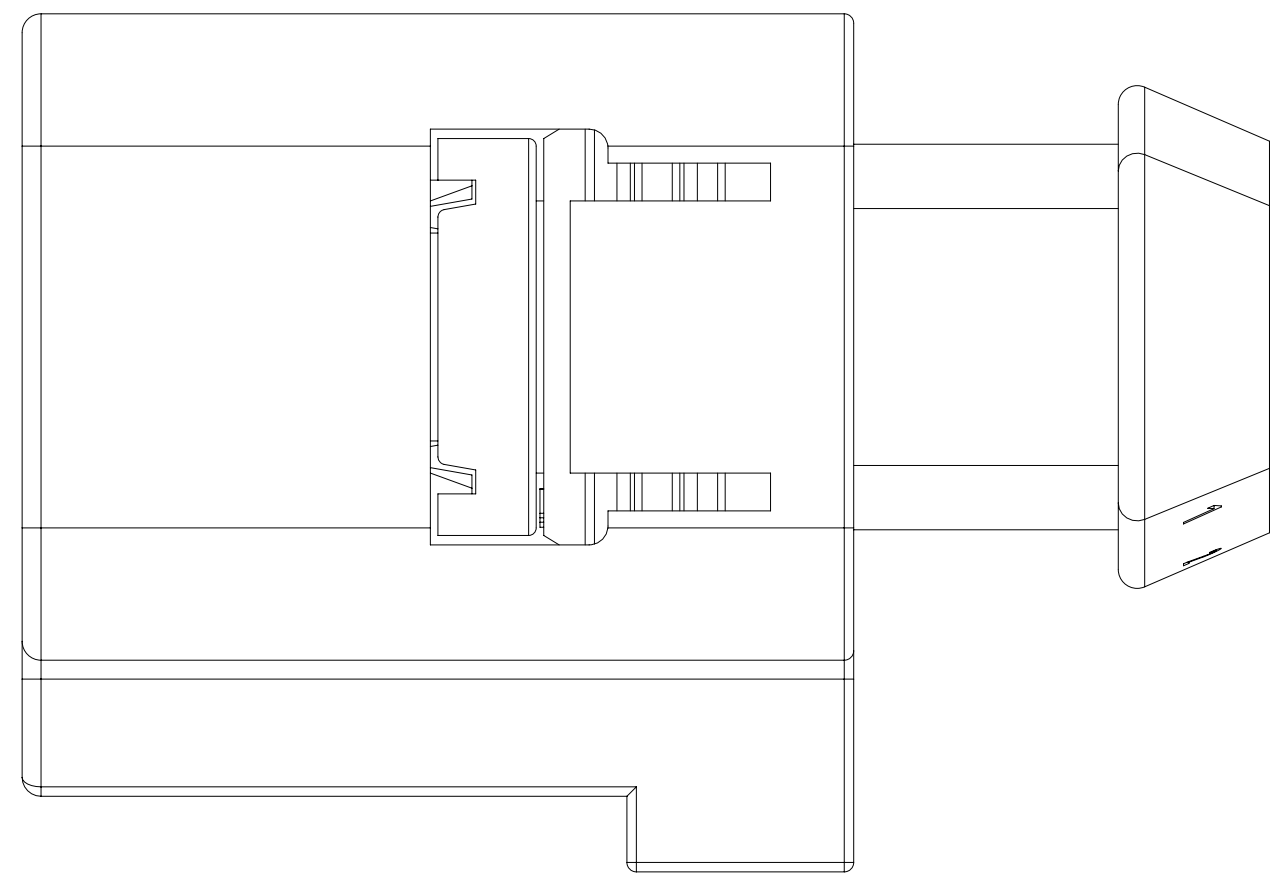
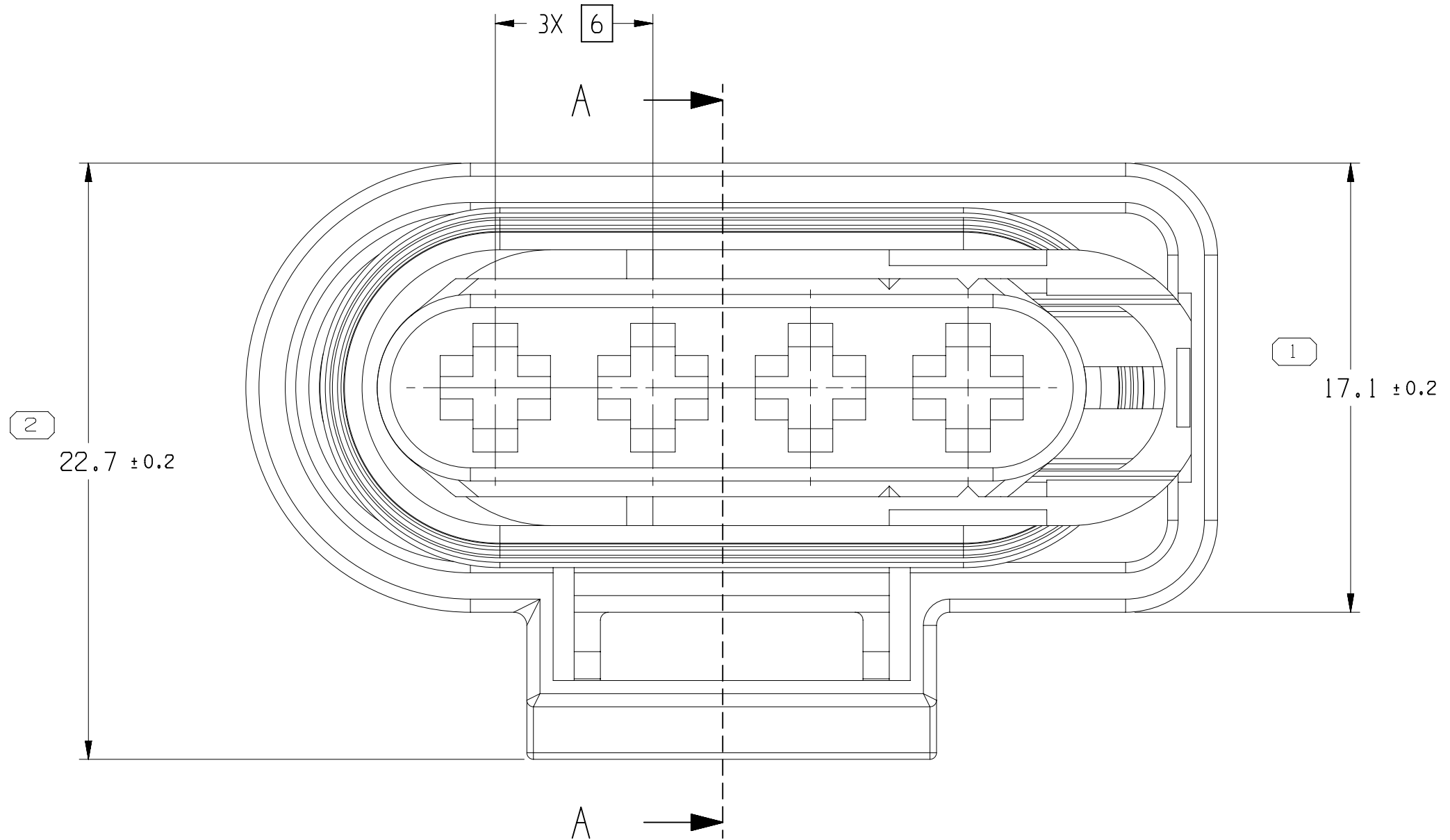
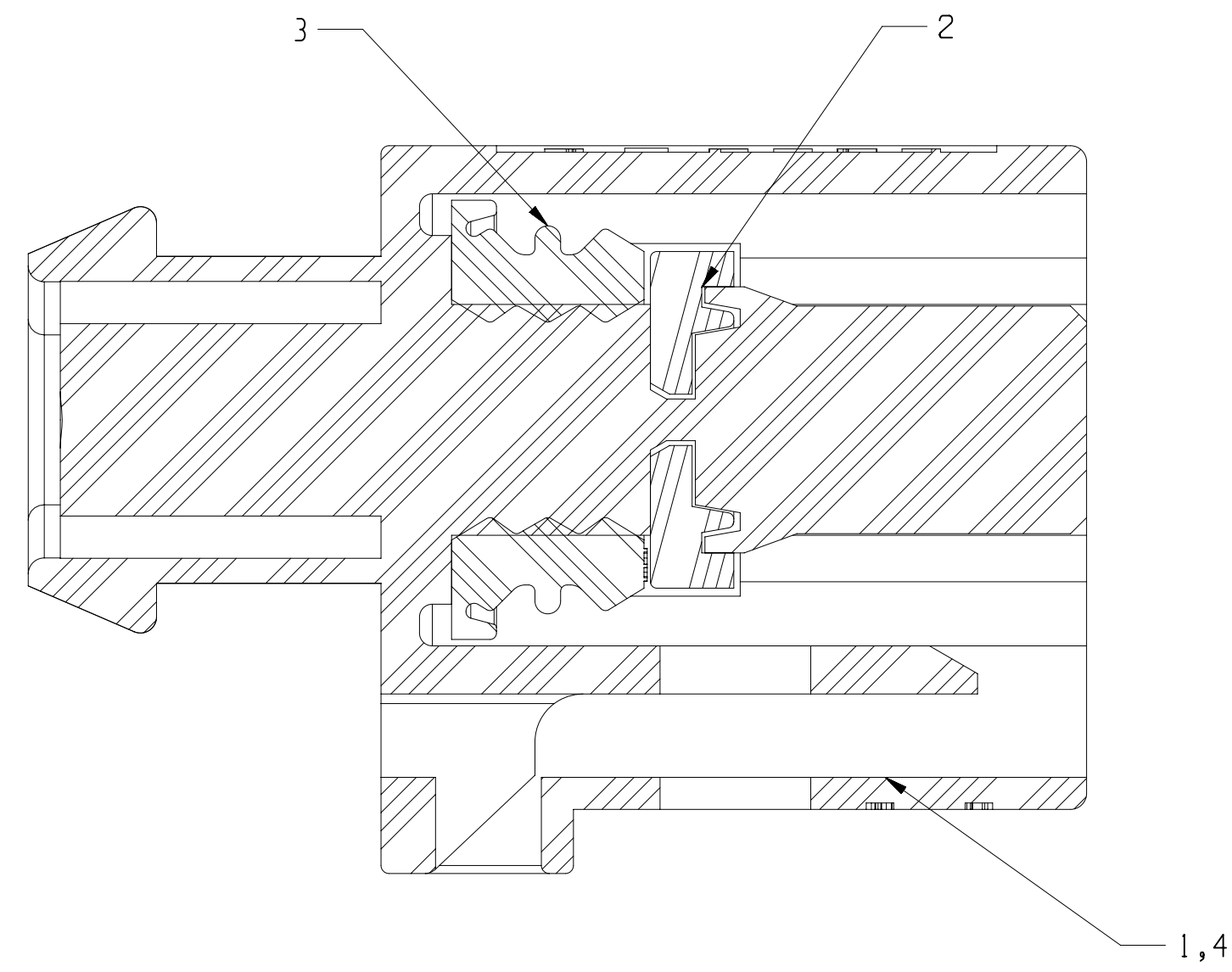
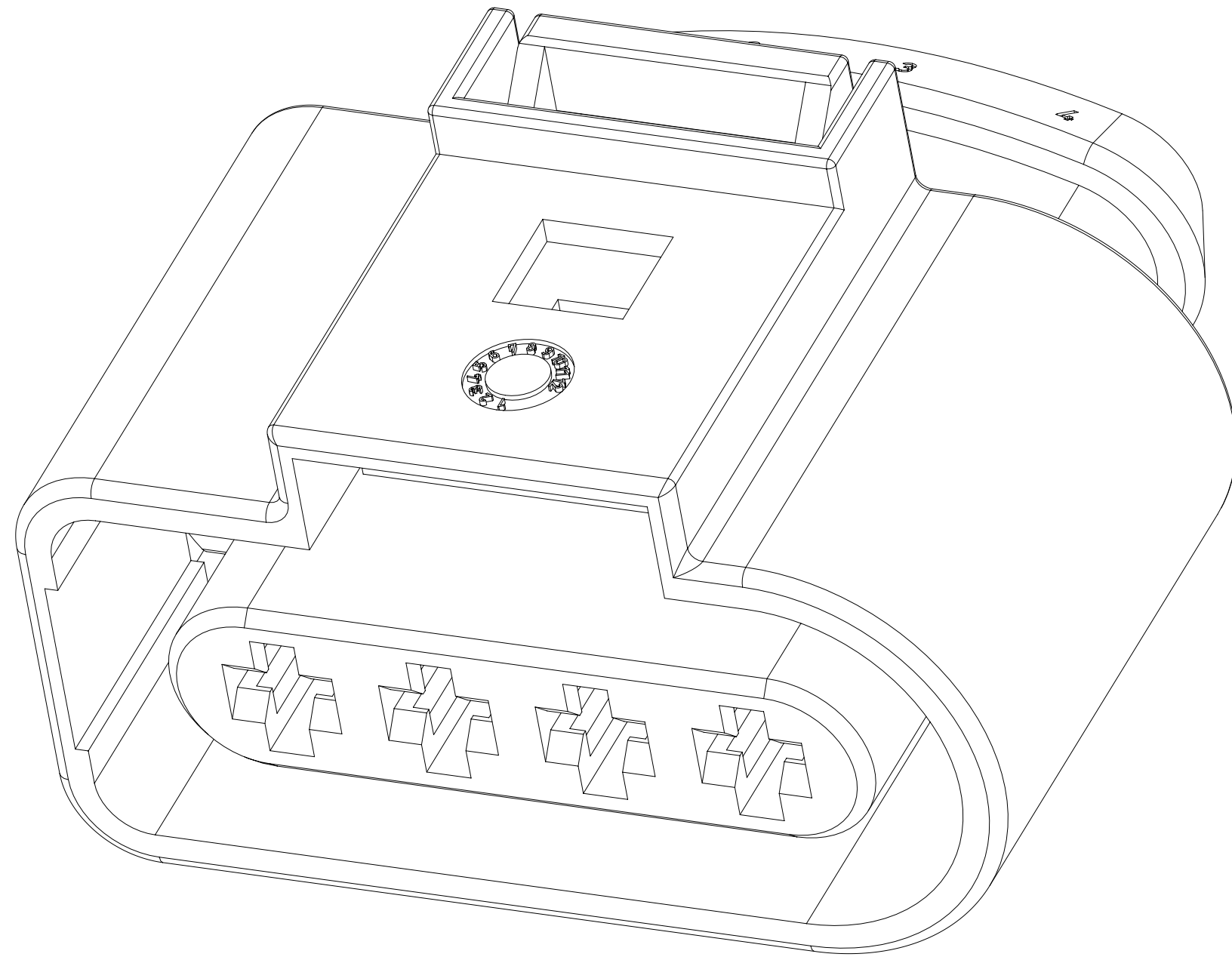

- NOTES
- UNLESS OTHERWISE SPECIFIED AND/OR INDICATED:
DIMENSIONS ARE TO FACE OF VIEW SHOWN AND AUTOMATICALLY ROUNDED BY COMPUTER FOR INSPECTION (SEE MATH MODEL FOR PRECISE DIMENSIONS). FOR ALL OTHER DIMENSIONS NOT SHOWN BUT REQUIRED FOR TOOL BUILD, SEE MATH MODEL FOR PRECISE TOOL PATH DATA.
 - FOR APPLICATION DATA SEE THE APPLICATION DRAWING.

SL. NO	PART NO	PART REV	PART NAME	REQ NO	PART COLOR
3	13603381		SEAL	1	ORANGE
2	13603376		TPA	1	PURPLE
4	35561135		CONNECTOR	1	BLACK
-	35561137	01	ASSEMBLY		
3	13603381		SEAL	1	ORANGE
2	13603376		TPA	1	PURPLE
1	13603380		CONNECTOR	1	BLACK
-	13603379	01	ASSEMBLY		

DIMENSIONAL RANGE (MM)		CHART	IP
FROM	> 0	> 30	> 70
TO	30	70	200
TOLERANCE UNLESS OTHERWISE SPECIFIED		> 250	> 315
		400	
		±0.1	±0.3
		±0.4	±0.55
		±0.7	±0.85
		±1.05	
		ANGULAR TOLERANCE	±1°

APTIV
CONNECTION SYSTEMS
Dermat, India
COPYRIGHT 2022 APTIV. ALL RIGHTS RESERVED.

THIS DRAWING IS THE PROPERTY OF APTIV AND CONTAINS APTIV CONFIDENTIAL INFORMATION. THE REPRODUCTION, DISTRIBUTION AND UTILIZATION OF THIS DOCUMENT OR ITS RELATED CAD DATA, AS WELL AS COMMUNICATION OF ANY CONTENT TO OTHERS, WITHOUT EXPRESS AUTHORIZATION, IS PROHIBITED.

DR	DATE
APVD1: M.KAVISUTHAN	18AP22
APVD2: ZHOU KEVIN HUJ	18AP22
APVD3: ZHENG JONNY	18AP22
APVD4:	

UNLESS OTHERWISE SPECIFIED
THIS DOCUMENT IS IN ACCORDANCE WITH ASME Y14.5M-1994 AS MODIFIED BY THE 2018 GLOBAL DIMENSIONING AND TOLERANCING ADDENDUM-2018. SEPARATE PATTERNING OF FEATURES MAY BE AWARDED SEPARATELY REGARDLESS OF DATUM REFERENCES.

ALL DIMENSIONS ARE IN MILLIMETERS

UNLESS OTHERWISE SPECIFIED
DIMENSIONS ENCLOSED IN () INDICATE REFERENCE DIMENSIONS AND NO TOLERANCE LIMITS ARE ESTABLISHED

THIRD ANGLE PROJECTION

DO NOT SCALE USE MATH DATA

DRAWING NAME
TAXI ASM CONN 4 F 2.8 TIMER SLD

DRAWING NUMBER
35645903

SIZE A0 SCALE 5:1 1 OF 1 SHEET NO 1 OF 1 REV 01