

Teil-Nr. / Part no.	Rev.	Teil-Nr. / Part no.	Rev.	Crimp-bereich / Crimp zone (mm ²)	Oberflaeche / Surface finish	Teilcode / Part code	B1 ±0.2	D1 ±0.3	(H1)	B2 ±0.2	D2 ±0.3	(H2)	A1 ±0.1	L1	L2 ±0.1
F438600	A	33504702	01	0.5-0.75	2.0 μm Au	4F	2.1	1.0	2.35	2.85	1.8	3.0	2.8	7.0	3.0
F338600	A	33504703	01		1.27 μm Au	4E									
F238600	A	33504704	01		0.8 μm Au	4D									
F038600	A	33504705	01		0.5 μm Au	4C									
F363310	A		01		1-3 μm SnAg	4H									
F323310	A	33514136	01	1.5-3 μm Ag	4G										
F538600	A	33504516	01	1-3 μm Sn	4A										
F479100	B	33500997	01	0.5 (0.5-0.75)	2.0 μm Au	3F	1.95	1.0	2.2	2.85	1.8	3.0	2.8	7.0	3.0
6 008 21 24	E	33504710	01		1.27 μm Au	3E									
6 008 11 34	E	13798988	01		0.8 μm Au	3D									
6 008 20 34	E	13589018	01		0.5 μm Au	3C									
6 008 11 31	F	13577654	01		1-3 μm Sn	3A									
F079100	B	33501000	01	0.22-0.35 (0.22-0.5)	2.0 μm Au	2F	1.7	0.8	1.9	2.5	1.6	2.6	2.5	7.0	3.0
6 008 21 14	E	33504713	01		1.27 μm Au	2E									
6 008 11 14	E	13577653	01		0.8 μm Au	2D									
6 008 20 14	E	13589019	01		0.5 μm Au	2C									
F263310	A		01		1-3 μm SnAg	2H									
F223310	A	33517251	01	1.5-3 μm Ag	2G										
F251410	A		01	1-3 μm Sn	2A									5.7	2.5
6 008 11 11	F	13651155	01	1-3 μm Sn	2A									7.0	3.0
F479800	A	33504718	01	0.12-0.18	2.0 μm Au	1F	1.65	0.8	1.4	2.25	1.5	2.0	2.8	7.0	3.0
F379800	A	33504719	01		1.27 μm Au	1E									
F279800	A	33504720	01		0.8 μm Au	1D									
F677100	A	33504721	01		0.5 μm Au	1C									
F163310	A		01		1-3 μm SnAg	1H									
F123310	A	33514139	01	1.5-3 μm Ag	1G										
F879800	A	33504517	01	1-3 μm Sn	1A										

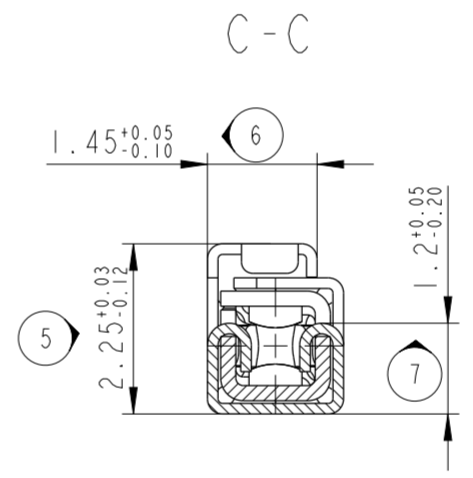

Bemerkungen / Notes	
28	1 Firmenzeichen / Supplier code
29	2 Teile Code / Part code
30	3 Woche der Herstellung / Week of production:
31	4 Jahr der Herstellung / Year of production: 2013=P; 2014=R; 2015=S...
5	Laserschweisspunkte / Laser welding points
6	Crimpbereich 0.5-0.75mm ² nur fuer bestehende Anwendungen erlaubt Crimp area 0.5-0.75mm ² only for existend applications allowed
7	Crimpbereich 0.22-0.5mm ² nur fuer bestehende Anwendungen erlaubt Crimp area 0.22-0.5mm ² only for existend applications allowed
8	Material
a	Grundkoerper / Contact body: CuNiSi
b	Ueberfeder / Hood: X10CrNi18 8 - acc. EN10151
Querverweise / Cross references	
9	Ausfuehrungsvorschrift fuer Flachstecker design order for male contact 0.62±0.02 x 0.62±0.02
10	Kammer / cavity
Toleranzen / Tolerances:	
12	DIN ISO 2768-fH; Masze / Dimensions <0.5 = ±0.05
13	DIN EN ISO 1101
14	Masze zur Teilevereinzlung gueltig fuer Kabelkonfektionier // Dimension for part separating valid for Harnessmaker
15	Spulen horizontal transportieren und lagern! Haltestreifen unten. // Reels transported and stored horizontal! Retaining strip down.
16	Durchgestrichene Teilenummern nur auf Anfrage Crossed out part no. only on request
17	Abweichungen von der bildlichen Darstellung im Bereich der Ueberfeder sind zulaessig. Deviations from the pictorial representation in the area of spring are allowed
18	Aenderungen die dem technischen Fortschritt dienen, behalten wir uns vor. changes reference to the technical progress, we reserve the right.
19	Massgebend ist nur der deutsche Text Only the german language shall be binding

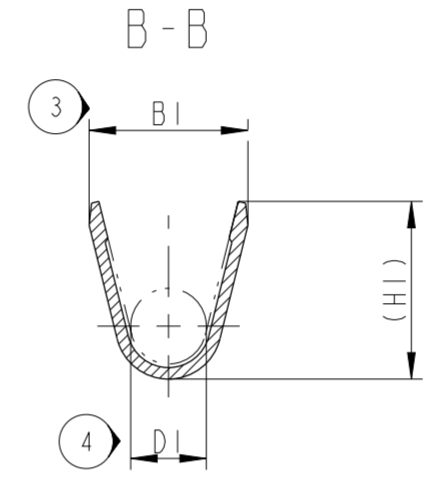
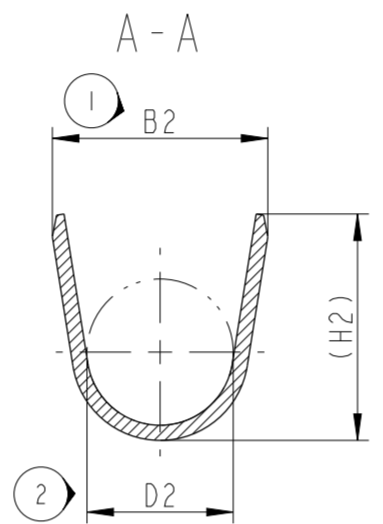
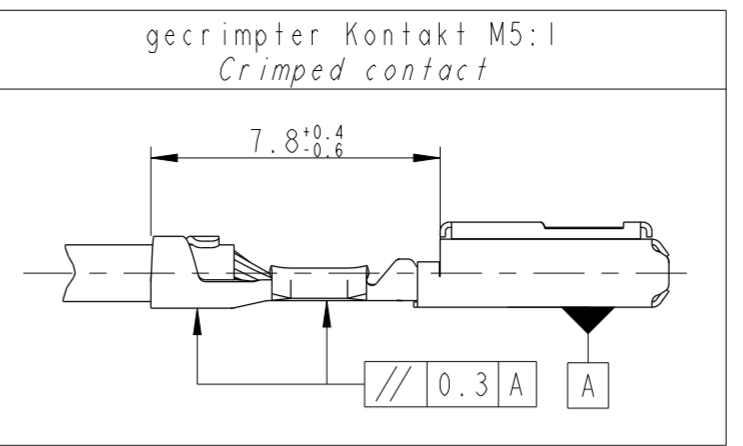
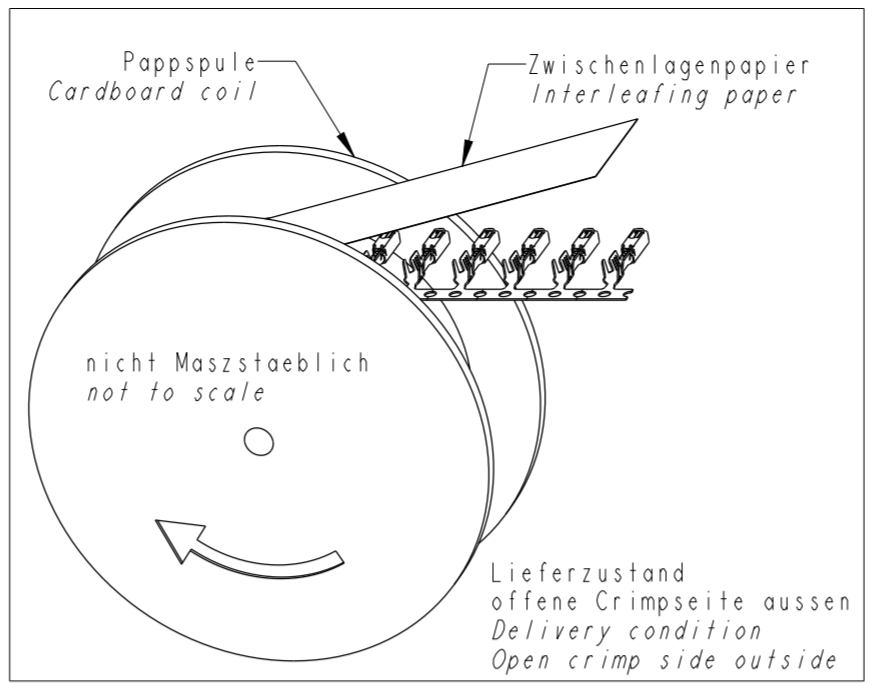
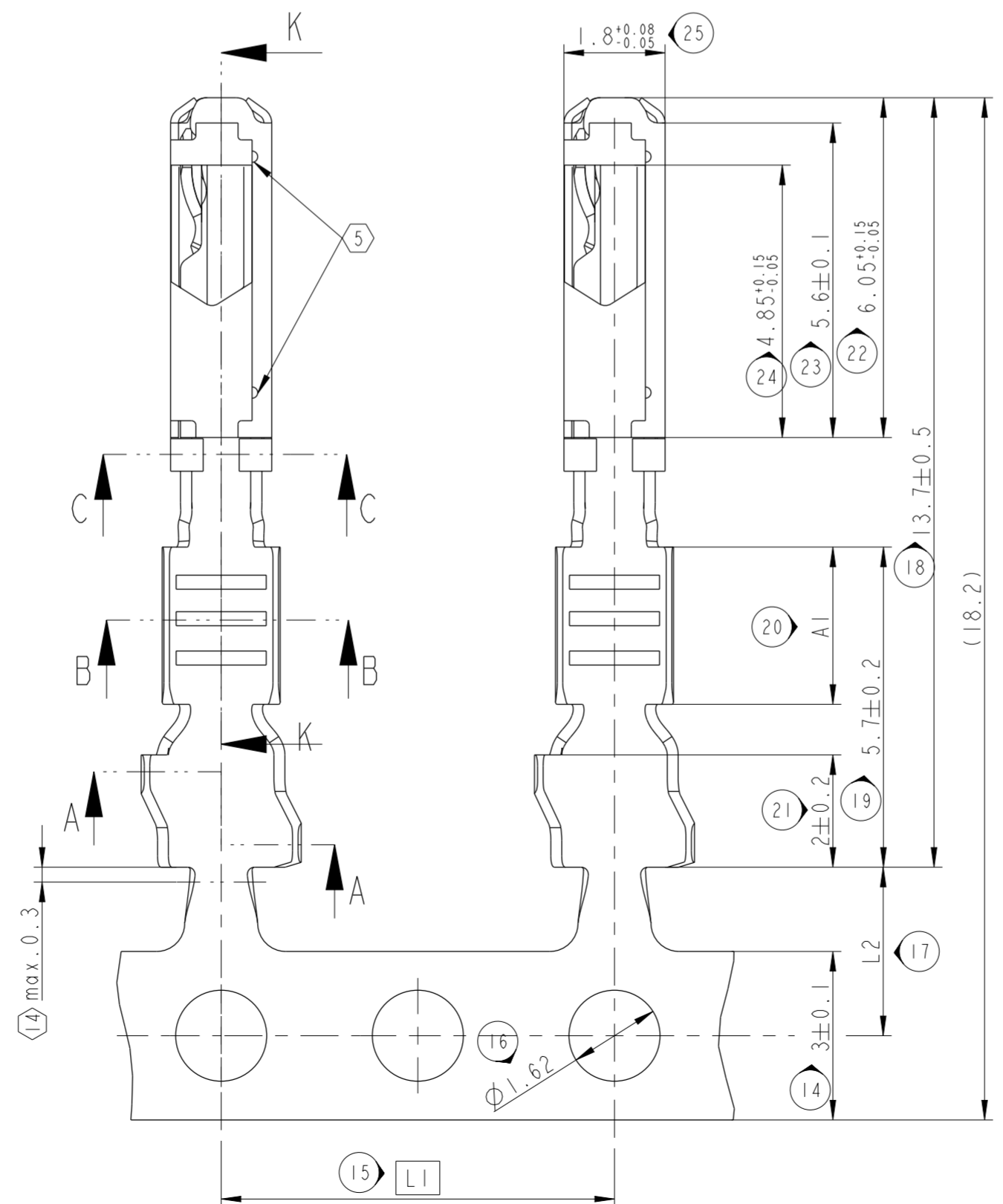
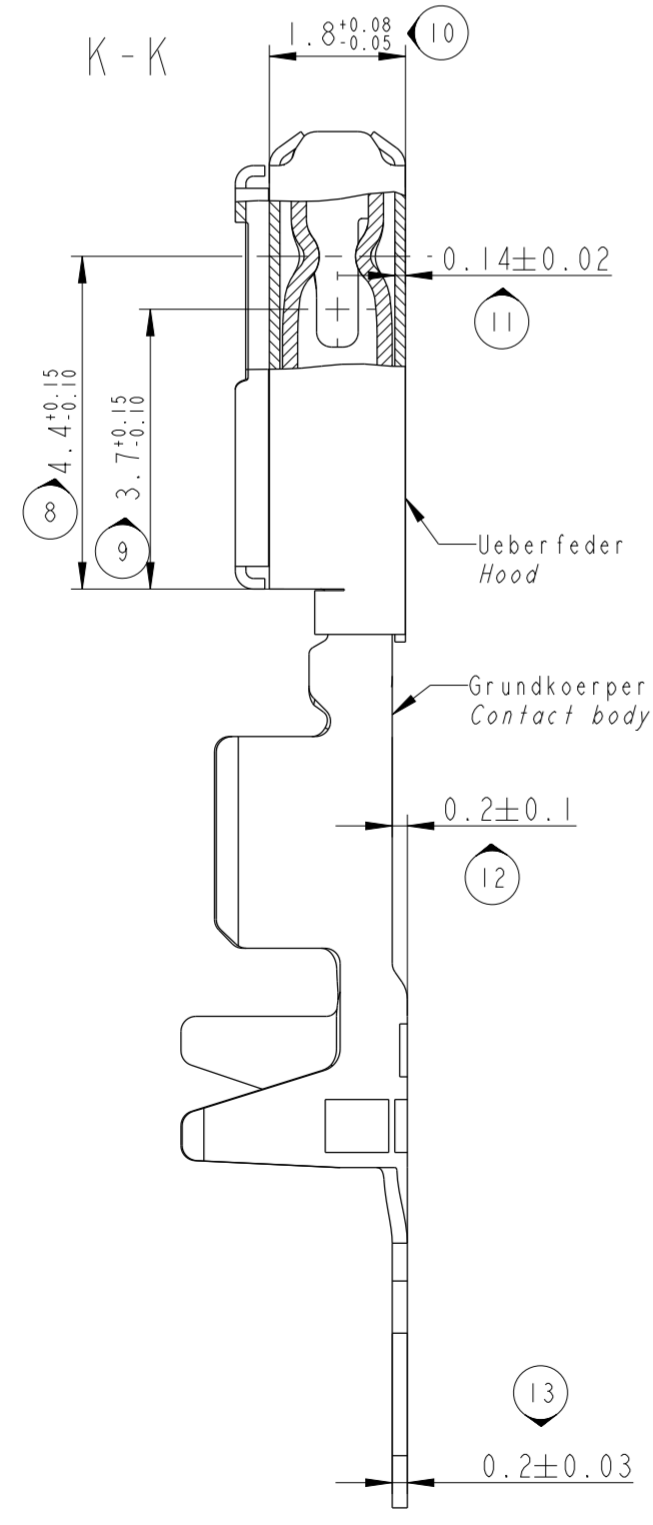

Dargestellt ist Crimbereich
Pictured is crimp area
0.5-0.75mm²

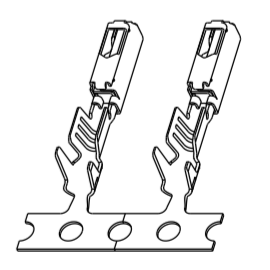

13-00851	Rev. "G" - 24.07.13: ADDED: 6x Part no. (Ag and SnAg); 1x Part no. F251410 table column Delphi no. and Rev. Changed: Crimp area 0.12-0.18 only on request; compl. rework of the table "notes"		
630/11	Rev. "F" - 22.08.11: ADDED: Crimp range 0.12-0.18mm ² with different contact finish		
ECN-NO. / ECN-NUMBER	POSITION / POSITION	CHANGE DESCRIPTION / AENDERUNGSBESCHREIBUNG	
PRODUCT SPEC. / PRODUKT-SPEZ.	PACKAGING SPEC. / VERPACKUNGS-SPEZ.	APPLICATION SPEC. / ANWENDUNGS-SPEZ.	COPYRIGHT DELPHI CORPORATION AND/OR ITS AFFILIATES. ALL RIGHTS RESERVED. REVISED THIS DRAWING IS THE PROPERTY OF DELPHI CORPORATION AND CONTAINS DELPHI CONFIDENTIAL INFORMATION. THE REPRODUCTION, DISTRIBUTION AND UTILIZATION OF THIS DOCUMENT OR ITS RELATED CAD DATA, AS WELL AS COMMUNICATION OF ANY CONTENT TO OTHERS, WITHOUT EXPRESS AUTHORIZATION, IS PROHIBITED.
9 901 02 61	---	9 084 12 10	DIESE ZEICHNUNG IST EIGENTUM DER FIRMEN DELPHI UND ENTHAELT DELPHI VERTRAULICHE INFORMATIONEN. DIE REPRODUKTION, VERTEILUNG UND NUTZUNG DIESER DOKUMENTE ODER DEREN INHALT OHNE DELPHI ZULASSUNG IST VERBODEN.
TOLERANCES / TOLERANZEN	siehe Bemerk. / see notes	MATERIAL: / MATERIAL:	SURFACE FINISH / OBERFLAECHE
COUNTERPART No. / GEGENSTUECK-Nr.	---	COLOUR: / FARBE:	---
DO NOT MEASURE DRAWING / ZEICHNUNG NICHT VERMESSEN	---	TOOL NO. / WERKZEUG-Nr.	---
DATE / DATUM	2011-08-24	NAME / NAME	St. Mueller
CREATED BY / ERSTELLT	2011-08-24	TITLE / BENENNUNG	064 Duo Twin female terminal
MODIFIED BY / GEAENDERT	2014/02/25	PROJECT / PROJEKT	Clean body non waterproof
CHECKED BY / GEPRUEFT	2014/02/25	ESR-NO. / ESR-NUMMER	---
APPROVED BY / GEWUEHRIGT	2014/02/26	CAT. NO. / KATALOG-Nr.	---
FILE NAME / DATE-NR.	60081111C	DOCUMENT UNDER PDS CONTROL / DOKUMENT IST IM PDS VERWALTET	NO MODIFICATION ALLOWED OUTSIDE / AENDERUNG AUSSERHALB NICHT ERLAUBT
DRAWING NUMBER / ZEICHN.-NUMMER		REV. / INDEX	APPROVAL LEVEL / FREIGABESTUFE
60081111C		G	A2
STATE STATUS / PART NUMBER / TEILENUMMER		REV. INDEX	SHEET BLATT / of 1 von 1
SERIAL RELEASED		REV. INDEX	SCALE / M: 5:1
See Table			