

SYMBOL DEFINITION		TOTAL NO OF INSPECTIONS REQUIRED	MISSING SYMBOLS
A DIMENSION WITHOUT AN INSPECTION REPORT SYMBOL () DOES NOT REQUIRE INSPECTION. IT MAY BE CONTROLLED ON THE INDIVIDUAL COMPONENT DRAWING.		4	NO MISSING SYMBOL NUMBER
	LAST NO. USED	4	

DWS STATUS		ZONE		REVISION HISTORY		AUTH	DR	APVD	APVD	
DATE	STG	REV	N/P	CHG						
22SE15	R	01	-	-	33111591 - WAS SEPARATE DRAWING AND 33273779 - RELEASED PART DRAWING	430398	RRR	RRR	RRR	TKS
25MY16	R	02	-	-	REVISED GRAPHICS	433085	SM	SM	TKS	TKS
15NO18	R	03	-	-	33111591 - UPDATED PART AVAILABILITY	441596	KRK	KRK	KST	KST
29NO18	R	04	-	-	33273779 - UPDATED PART AVAILABILITY	441739	SM	RRR	KST	KST
20MY21	R	05	-	-	ALL PARTS - REVISED GRAPHICS	553821	VS	KV	TKS	TKS

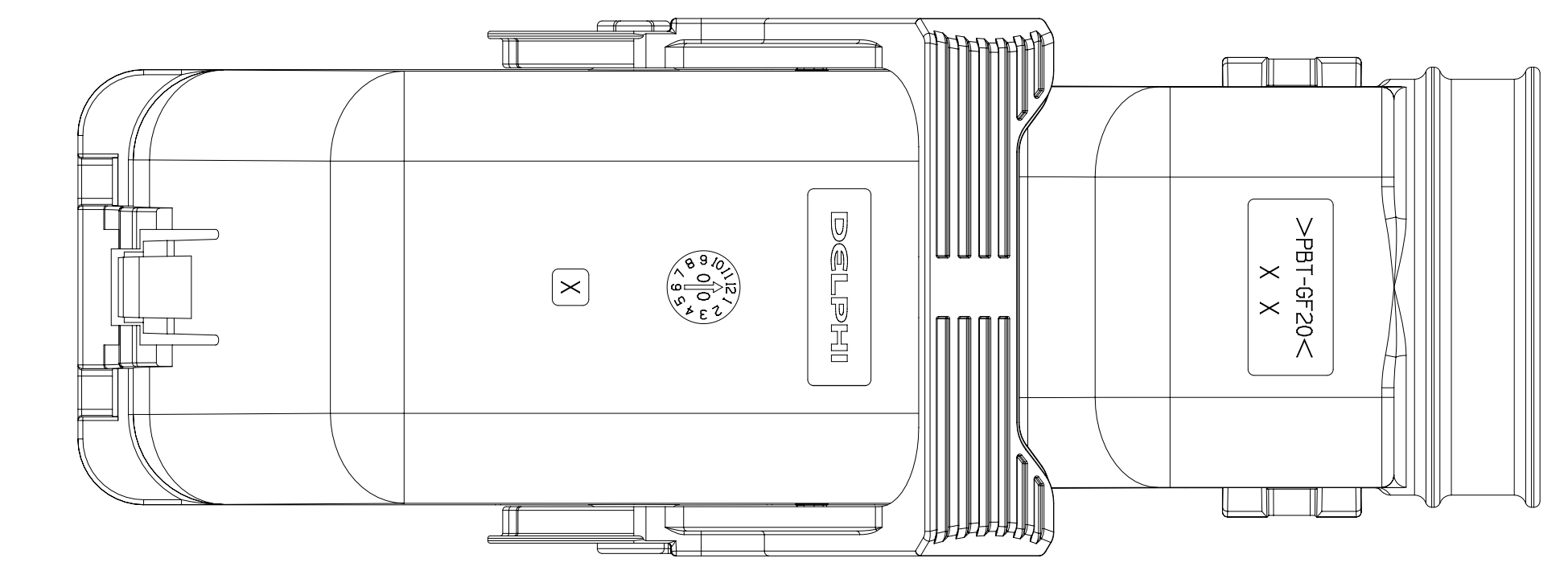
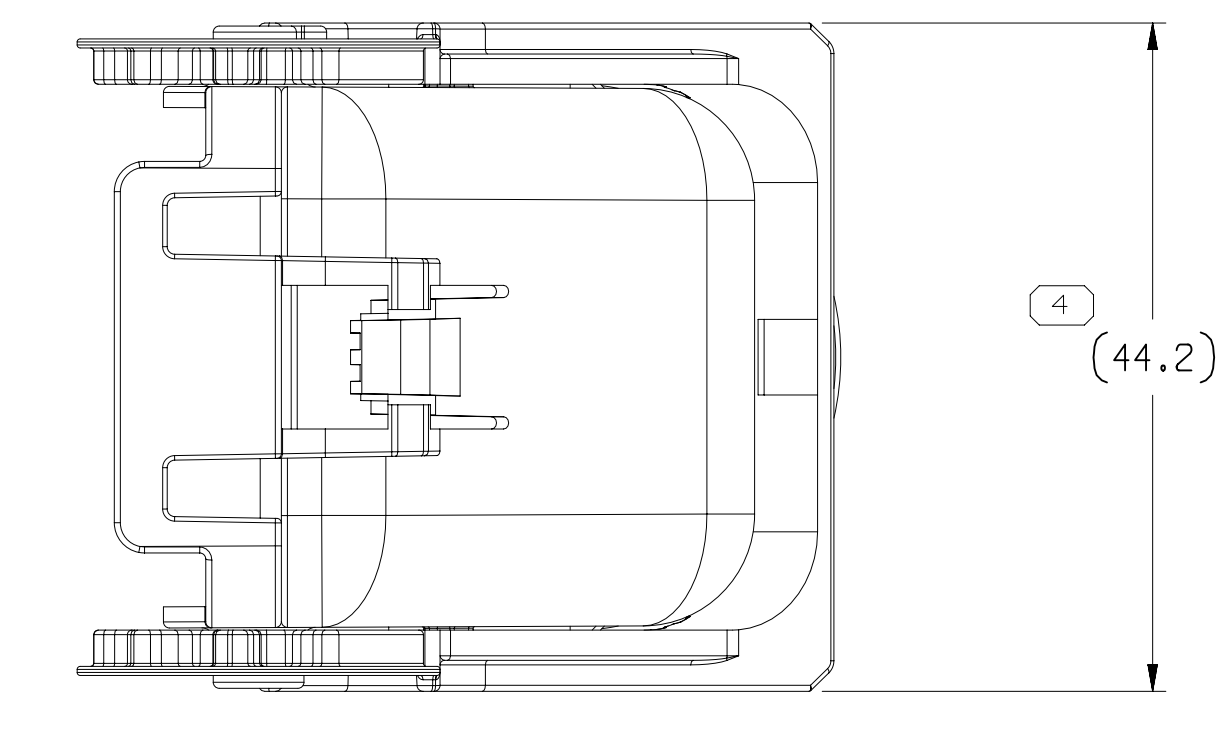
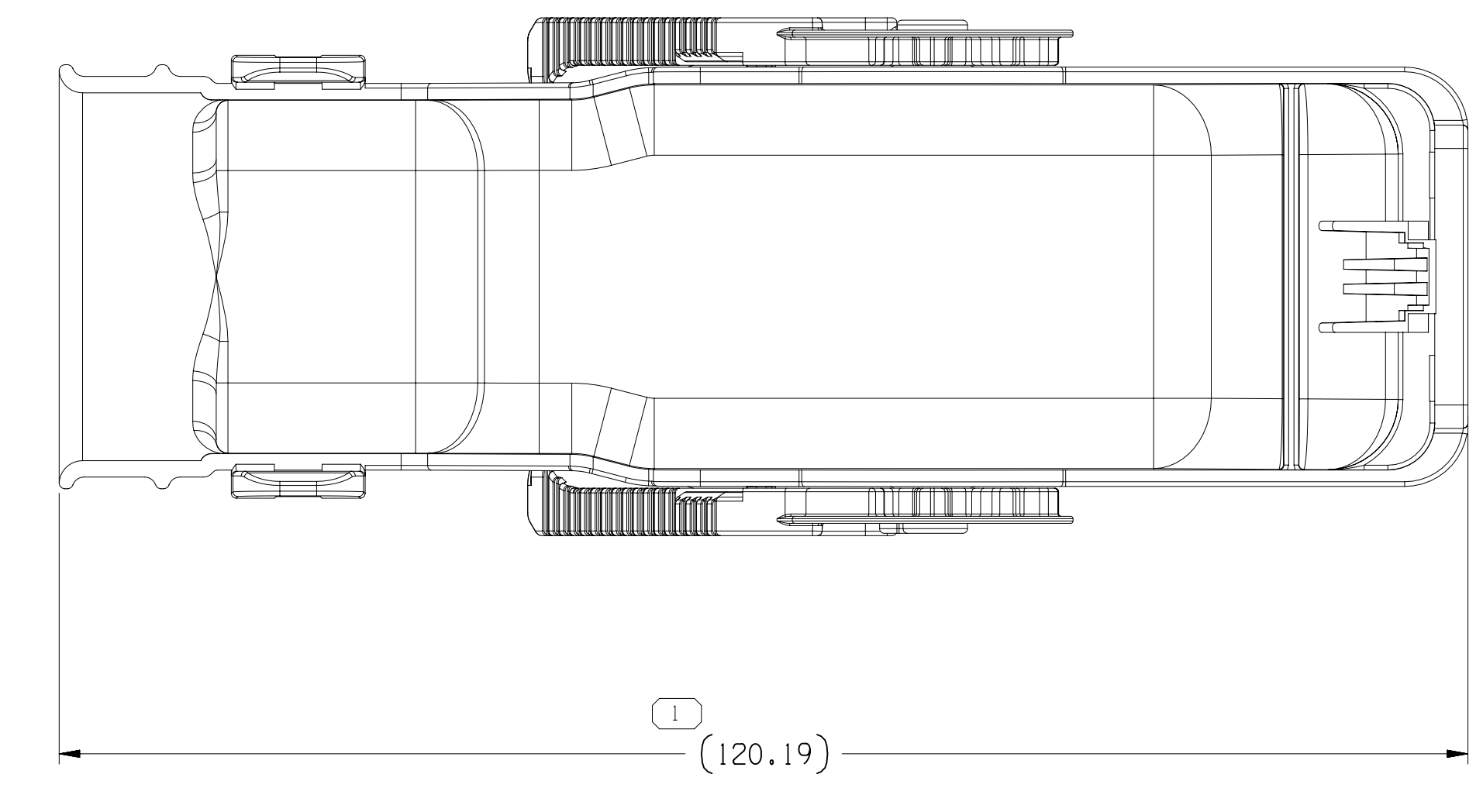
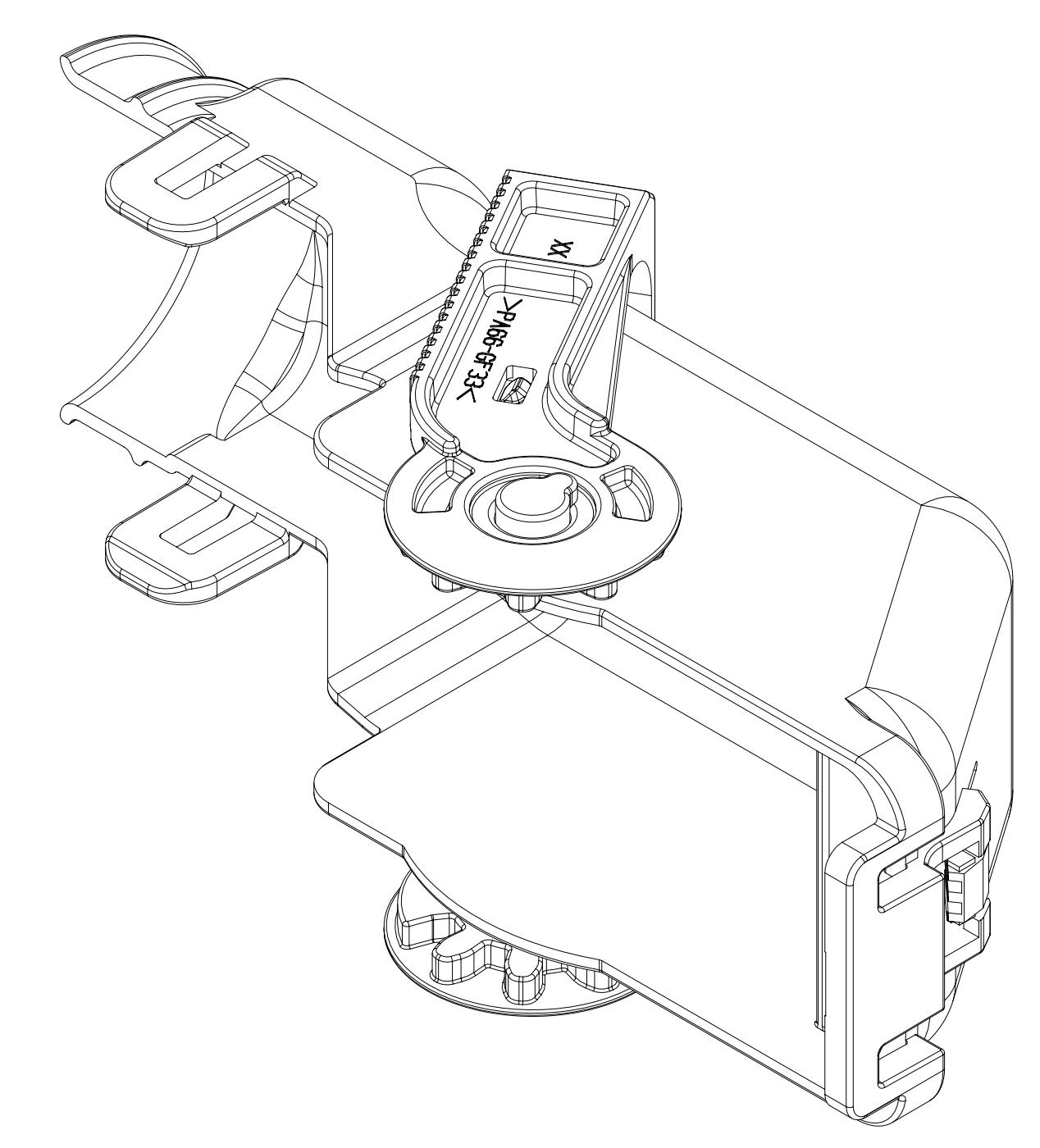
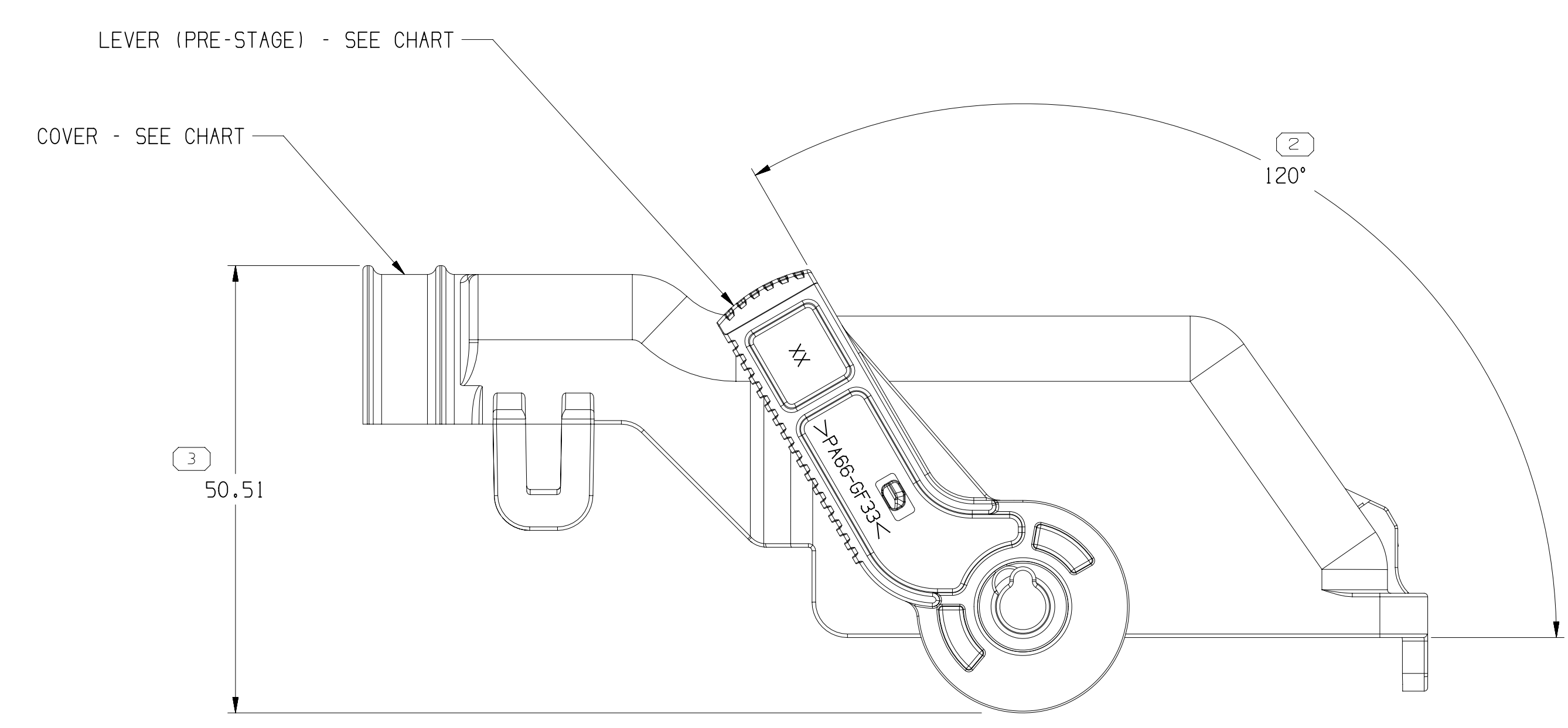

NOTES

- UNLESS OTHERWISE SPECIFIED AND/OR INDICATED:
DIMENSIONS ARE TO FACE OF VIEW SHOWN AND AUTOMATICALLY ROUNDED BY COMPUTER FOR INSPECTION (SEE MATH MODEL FOR PRECISE DIMENSIONS). FOR ALL OTHER DIMENSIONS NOT SHOWN BUT REQUIRED FOR TOOL BUILD, SEE MATH MODEL FOR PRECISE TOOL PATH DATA.
- THIS PRODUCT IS NOT CATEGORIZED AS AN APPEARANCE ITEM, MINOR IMPERFECTIONS INCLUDING, BUT NOT LIMITED TO, FLOW MARKS, COLOR BLEMISHES, GATE VESTIGES, AND SOFT FLASH THAT DO NOT AFFECT THE FIT, FORM, OR FUNCTION OF THE PART ARE PERMISSIBLE PER DPNP-4.7-CS-01.
- REFERENCE MATING COMPONENTS OR EQUIVALENT:
TAXI ASM CONNECTOR 33111404
- THIS ASSEMBLY MUST BE SHIPPED AS SHOWN.
- THIS ASSEMBLY WAS DESIGNED WITHOUT CPA.

PART NO	REV	N/P	COVER	LEVER	REMARKS
33273779	03	-	33273778	33273775	VO
33111591	03	-	33111589	33111396	NON-VO

DIMENSIONAL RANGE (MM)	CHART	ET
FROM TO	>0 >20 >30 >70 >100 >150 >200 >250 >300 >400	
	±0.15 ±0.2 ±0.3 ±0.4 ±0.5 ±0.6 ±0.8 ±1 ±1.2	
	ANGULAR TOLERANCE ±2°	

APTIV
CONNECTION SYSTEMS
Chennai, India
COPYRIGHT 2015 APTIV. ALL RIGHTS RESERVED.
THIS DRAWING IS THE PROPERTY OF APTIV AND CONTAINS APTIV CONFIDENTIAL INFORMATION. THE REPRODUCTION, DISTRIBUTION AND UTILIZATION OF THIS DOCUMENT OR ITS RELATED CAD DATA, AS WELL AS COMMUNICATION OF ANY CONTENT TO OTHERS, WITHOUT EXPRESS AUTHORIZATION, IS PROHIBITED.

DR	R. RAMASWAMY	DATE	21SE15
APVD1	R. RAMASWAMY	DATE	21SE15
APVD3	TURNER KEVIN.S	DATE	22SE15
APVD4			
APVD5			

UNLESS OTHERWISE SPECIFIED THIS DOCUMENT IS IN ACCORDANCE WITH ASME Y14.5M-1994 AS MODIFIED BY THE 0M GLOBAL DIMENSIONING AND TOLERANCING ADDENDUM-2002. SEPARATE PATTERNING OF FEATURES MAY BE ORDERED SEPARATELY. REGARDLESS OF DATUM REFERENCES.

ALL DIMENSIONS ARE IN MILLIMETERS

THIRD ANGLE PROJECTION

DO NOT SCALE USE MATH DATA

DRAWING NUMBER

33275464

SIZE A0

SCALE 2:1

FRAME NO 1

SHEET NO 1 OF 1

STG REV N/P

R 05