

DATA SHEET

900MM GAS ON STEEL COOKTOP

Model no:

CG905DX1

NB. Supplied for NG with an LPG conversion kit included.

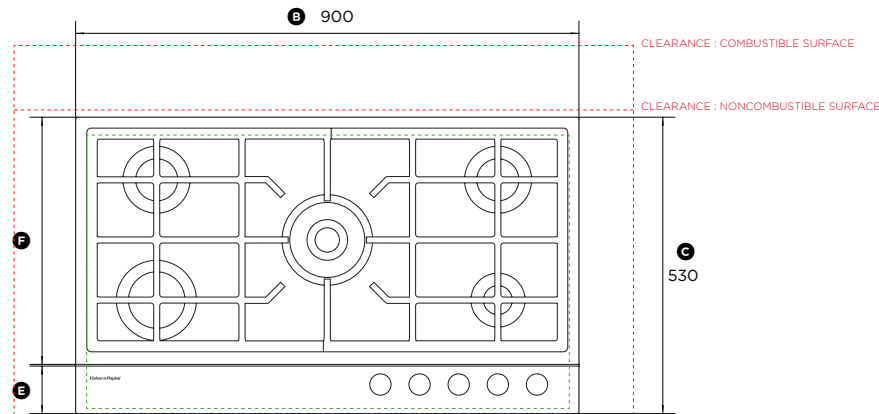

PLAN VIEW

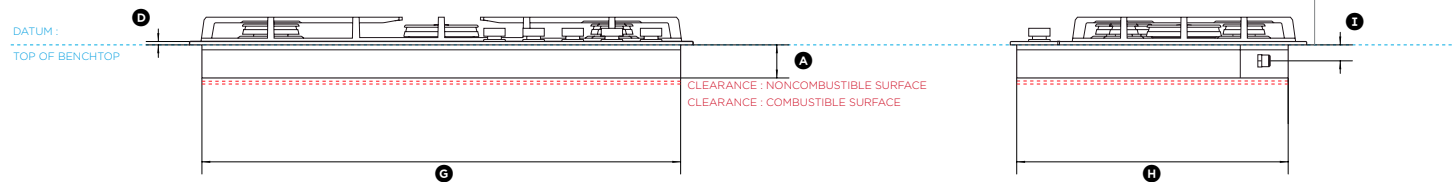

FRONT VIEW

PROFILE VIEW

Dimensions	mm
Ⓐ Height of chassis (below top of benchtop)	59
Ⓑ Overall width of cooktop	900
Ⓒ Overall depth of cooktop	530
Ⓓ Height from counter datum to top of cooktop surface	6
Ⓔ Depth of front control panel	85
Ⓕ Depth of cooktop cooking area	442
Ⓖ Width of chassis	856
Ⓗ Depth of chassis	486
Ⓘ Distance from top of counter to centre of gas inlet on product	30

Minimum Clearances	mm
Minimum clearance from left edge of cutout to nearest vertical surface	130
Minimum clearance from right edge of cutout to nearest vertical surface	115
Minimum clearance from rear edge of cutout to nearest combustible surface	160
Minimum clearance from rear edge of cutout to nearest non-combustible surface	45
Minimum clearance below top of benchtop to combustible surface	70
Minimum clearance below top of benchtop to Fisher & Paykel oven or nearest non-combustible surface	65
Minimum clearance from cooktop surface to downwards-facing tiled or fire resistant surface	500
Minimum clearance from cooktop surface to rangehood or downward facing combustible surface	650
Minimum clearance from cooktop surface to any other overhead exhaust fan	800

Cutout Dimensions	mm
Overall width of cutout*	865
Overall depth of cutout*	490

* Note cutout position is centred to the cooktop width but offset to the cooktop depth. Cutout front depth is 9mm from the front edge of the product.

INDICATES PRODUCT DATUM -----
 INDICATES CLEARANCES -----
 INDICATES CUTOUT -----

DATE: **29.07.2015**

IMPORTANT NOTE: Throughout this guide, dimensions may vary by $\pm 2\text{mm}$ ($3/32''$). Please read the installation manual for detailed information on installing the product. www.fisherpaykel.com



Fisher & Paykel