



HP4100 Hopper Cap Easily Broken

www.scc-inc.com

Critical Issues:

HP4100 hopper cap easily damaged

Cartridge may break during cap removal

Damaged hopper cap causes leakage

Recommendations:

Static Control is currently developing a replacement hopper cap for the HP4100

HP4100 Hopper Cap Problem

Static Control's engineering and development teams have discovered that the HP4100 hopper cap can be damaged and the cartridge broken when attempting to remove the cap. A damaged hopper cap will cause leakage.

HP4100 Hopper Cap Damage Cause

The HP4100 hopper cap has flanged lips on each side (inner and outer) of the hopper. Attempting to remove the cap will usually result in the cap being damaged and deformed. On some occasions when attempting to remove the cap the cartridge will break.

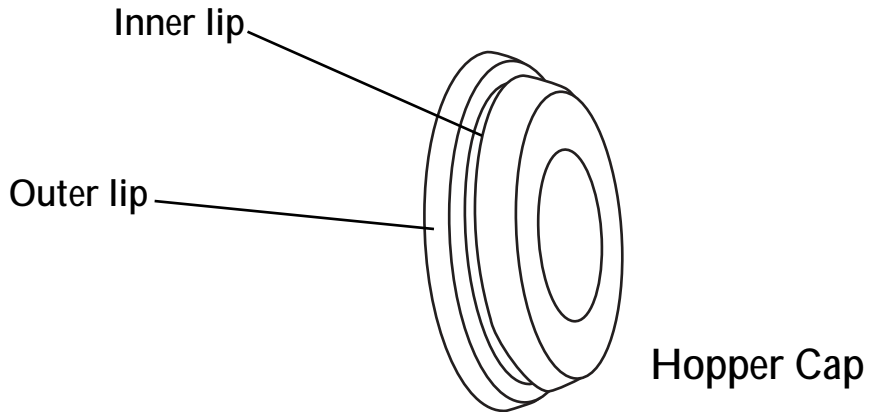

US AND CANADA SALES

Voice: 800.488.2426

Fax: 800.488.2452

INTERNATIONAL SALES

Voice: 919.774.3808

Fax: 919.774.1287

Static Control is developing a HP4100 hopper cap solution to address the breakage issue and will have a replacement hopper cap by early August.

*** Get additional information on this topic and more!**

Our Web site's new Premium Content section has additional information on this topic. Qualified customers receive access to more than 500 documents including remanufacturing instructions, product instructions, technical bulletins, industry alerts, product updates and market updates.

*** How do I get Premium Content access?**

Call your Static Control Support Team. Qualified customers instantly obtain our entire online library of technical documentation!



3010 Lee Avenue
PO Box 152
Sanford, NC 27330