



AMERICAN FORGE & FOUNDRY

MODEL NO.: 352SD



3.5-Ton Floor Jack — Super Duty Owner's Manual



WARNING:

IMPORTANT: READ THESE INSTRUCTIONS AND ALL WARNINGS PRIOR TO USING THIS EQUIPMENT. UNDERSTAND ALL OPERATING PROCEDURES, SAFETY WARNINGS AND MAINTENANCE REQUIREMENTS. FAILURE TO DO SO COULD CAUSE AN ACCIDENT RESULTING IN SERIOUS OR FATAL INJURY AND/OR PERSONAL PROPERTY DAMAGE.

A



Brand

surewerx.com

AFF 352SD-INST-3.23.23-FA



GENERAL DESCRIPTION

PRODUCT DESCRIPTION

Hydraulic floor jacks are designed to lift, but not support, one end of a vehicle. Immediately after lifting, loads must be supported by a pair of appropriately rated jack stands.

SAFETY INFORMATION

WARNING

- 2.1 Locate the jack in a suitable working area.
- 2.2 Inspect the jack before each use. Do not use jack if damaged, altered, modified, in poor condition, leaking hydraulic fluid, or unstable due to loose or missing hardware or parts. Make corrections before using.
- 2.3 Use jack on level and solid ground.
- 2.4 Ensure the vehicle handbrake is engaged, engine is switched off and transmissions in gear (or "PARK" if automatic).
- 2.5 Ensure minimum distance of 0.5 m between vehicle and static objects such as doors, walls, etc., to allow for vehicle tilting.
- 2.6 Ensure all non-essential persons keep a safe distance while the jack is in use.
- 2.7 Do not exceed rated capacity of jack.
- 2.8 Place jack under only those lifting points recommended by vehicle manufacturer (see vehicle handbook).
- 2.9 Check that the lifting point is stable and centered on the jack saddle.
- 2.10 Ensure the jack wheels are free to move and that there are no obstructions.
- 2.11 Use suitable axle stands under the vehicle before proceeding with any task.
- 2.12 Ensure there are no persons or obstructions beneath the vehicle before lowering.
- 2.13 Ensure proper routine maintenance is performed by a qualified individual.
- 2.14 Wear ANSI-approved safety goggles and heavy-duty working gloves during use.
- 2.15 When not in use store jack, fully lowered, in a safe, dry, childproof location.

DO NOT operate the jack if damaged.

DO NOT allow untrained persons to operate the jack.

DO NOT exceed the rated capacity of the jack.

DO NOT move or dolly the vehicle while it is on the jack.

DO NOT lift vehicle if there is a risk of spillage of fuel, battery acid, or other dangerous substances.

DO NOT work under the vehicle until appropriately supported.

DO NOT fill hydraulic system with brake fluid, alcohol or transmission oil. Use hydraulic jack oil only.

DO NOT adjust the safety overload valve.

The warnings, precautions, and instructions discussed in this manual cannot cover all possible conditions and situations that may occur. The operator must understand that common sense and caution are factors, which cannot be built into this product, but must be supplied by the operator.



WARNING: This product can expose you to chemicals including nickel, which is known to the State of California to cause cancer and birth defects or other reproductive harm. For more information go to www.P65Warnings.ca.gov



ASSEMBLY

3.1 IMPORTANT RECEIVING INSTRUCTIONS

Visually inspect all components for shipping damage. If any shipping damage is found, notify carrier at once. Shipping damage is NOT covered by warranty. The carrier is responsible for all repair or replacement cost resulting from damage in shipment.

3.1.1 CHECK THE PARTS IN THE CARTON

Visually inspect all components for any missing parts or damage. Refer to the packing list below.

No.	Description	Qty
1	Handle tube 1	1
2	Handle tube 2	1
3	Jack body	1
4	Instruction manual	1

3.2 ASSEMBLY

3.2.1 The jack comprises the following parts: Jack body, two-part pumping handle.

3.2.2 Unscrew the bolt from handle tube 1. Insert the upper handle into the lower handle. Secure the two pieces together with the bolt (A).

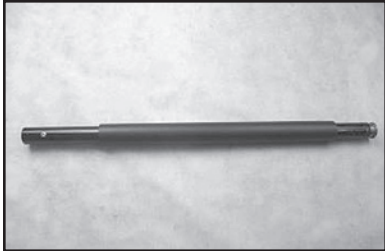

Handle tube 1

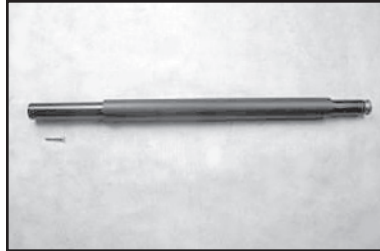

Unscrew the bolt from the handle

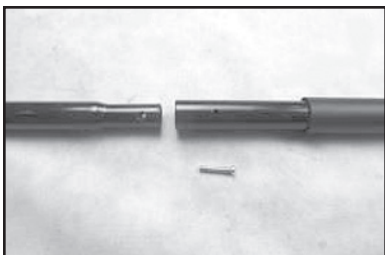

Insert the upper tube

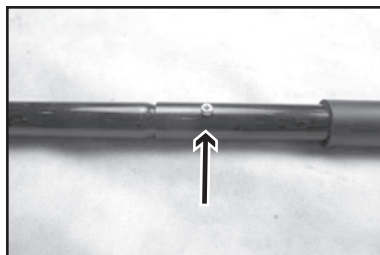

Tighten the bolt

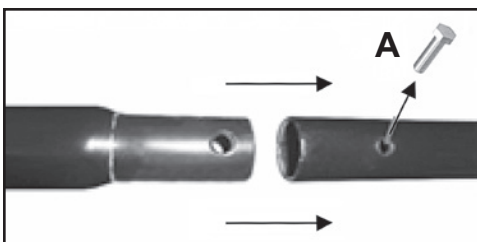



- 3.2.3 Undo the screw (B) in the handle socket, until it no longer protrudes into the handle socket.
- 3.2.4 Insert the pump handle into the handle socket hole completely.
- 3.2.5 Ensure that the handle is completely inserted into the socket, then tighten the handle socket screw (B). Please make sure that the handle can be turned smoothly

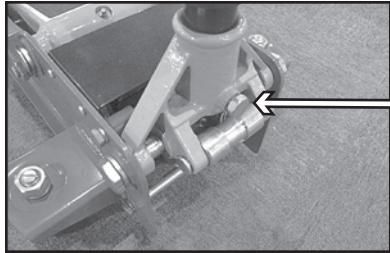

B

HYDRAULIC SYSTEM PURGING

- 4.1 Open the release valve by turning it two full turns counter-clockwise.
- 4.2 Pump the handle a minimum of four full strokes quickly.
- 4.3 Close the release valve by turning it clockwise.
- 4.4 Pumping the handle with full strokes to check if it can reach the maximum height by eight pumps.

If it can't reach the maximum height by eight pumps, please refer to the following special purging process:

- 4.5 Open the release valve by turning counter-clockwise and lower the lifting arm to the minimum height.
- 4.6 Put the jack on a flat working table, carefully lift and support the front part of the jack to make sure the front part is at least 500 mm higher than the end part of the jack.
- 4.7 Pump the handle a minimum of four full strokes quickly.
- 4.8 Put the jack on a flat surface and close the release valve by turning it clockwise.
- 4.9 Pumping the handle with full strokes to check if it can reach the maximum height by eight pumps, if not please repeat the special purging process again.



OPERATING INSTRUCTIONS

⚠ WARNING

Before use ensure you have read and understood **Section 2, Safety Information**.

⚠ IMPORTANT

Before use, the operator is to visually inspect the jack for cracked welds, damaged or missing parts or hydraulic leak.

5.1 RAISING A VEHICLE

- 5.1.1 Ensure that the jack and the vehicle are on a hard, level surface.
- 5.1.2 Always ensure that the vehicle handbrake is engaged and that the vehicle wheels are chocked.
- 5.1.3 Consult the vehicle manual to determine the location of jacking points. Position the jack under a suitable lifting point.
- 5.1.4 Turn the handle clockwise, to close release valve. **DO NOT** over-tighten.
- 5.1.5 Raise the vehicle to the desired height by pumping the handle up and down.
- 5.1.6 Immediately support the vehicle with appropriate means such as vehicle support stands.
- 5.1.7 Turn the release valve slowly counter-clockwise to lower the vehicle on to the vehicle support stands.

5.2 LOWERING A VEHICLE

- 5.2.1 Ensure that the area under and around the vehicle is clear of people and obstructions.
- 5.2.2 Turn the release valve clockwise to close it.
- 5.2.3 Pump the handle to raise the vehicle off the vehicle support stands.
- 5.2.4 Remove the vehicle support stands from beneath the vehicle.
- 5.2.5 Turn the release valve slowly counter-clockwise to lower the vehicle to the ground.

NOTE: When the jack not in use, **ALWAYS** leave the saddle and ram fully retracted.

CAUTION: Keep hands and feet away from the hinge mechanism of the jack.

IMPORTANT: Only fully qualified personnel should attempt maintenance or repair.



MAINTENANCE

6.1 MONTHLY MAINTENANCE

Periodic lubrication is critical to jacks. Any restriction due to dirt or rust can cause either slow jack movement, or extremely rapid jerks, causing damage to the internal components. To keep the jack well lubricated, carry out the following steps.

6.1.1 Lubricate the linkages the saddle and pump mechanism with light oil.

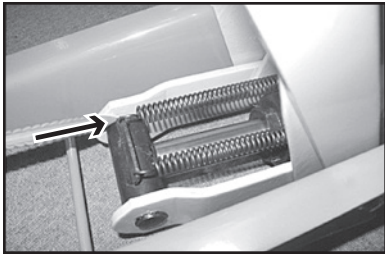

Linkage (1)

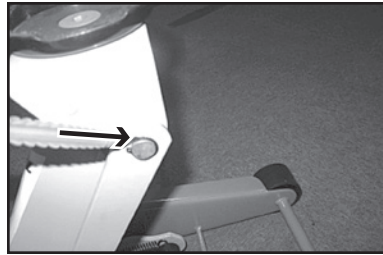

Linkage (2)

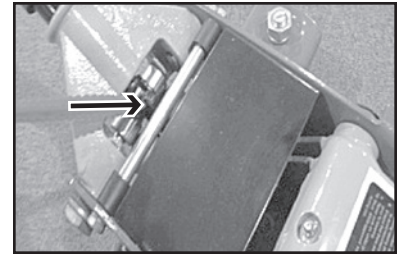

Linkage (3)

6.1.2 Grease the wheel bearing and axles.

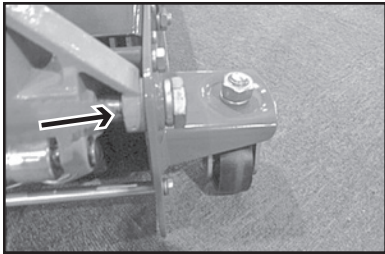

Roller Pin (right)

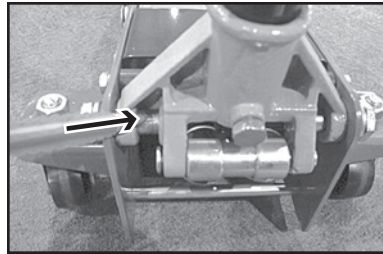

Roller Pin (left)

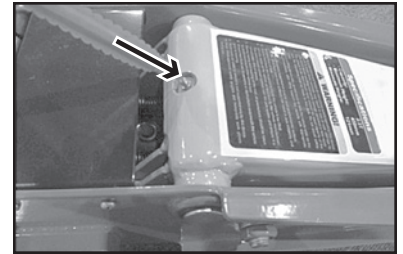

Lifting Arm

6.1.3 Keep all jack surfaces and warning labels clean.

6.2 TRI-MONTHLY MAINTENANCE

6.2.1 At tri-monthly intervals, check the pump for any signs of rust or corrosion. Clean the pump as required and wipe with an oil cloth.

6.3 CHECKING THE OIL LEVEL

6.3.1 Fully retract the ram by turning the release valve counter-clockwise.

6.3.2 Loosen and take off the four top plate retaining screws and remove the top plate vertically as pictured below.

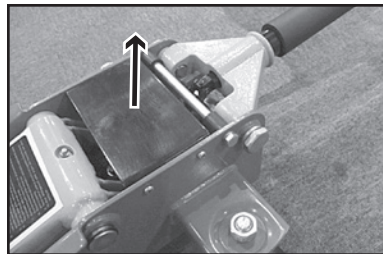
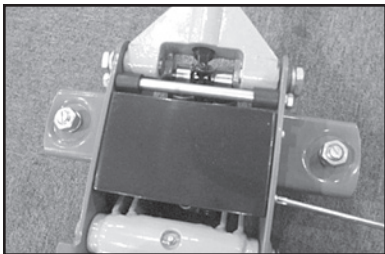



- 6.3.3 With the jack in the level position, remove the oil filler plug.
- 6.3.4 The proper oil volume should be the maximum distance from the oil surface level to the top of pump and should be less than 11 mm. If there is not enough oil, please add hydraulic oil according to Section 6.4.
- 6.3.5 Replace the oil filler plug.
- 6.3.6 After adding oil, please checking if the jack can reach the maximum height with eight pumps. If not, please purge air from the hydraulic unit as required. Refer to Section 4.
- 6.3.7 Cover the top plate, then tighten the four screws.

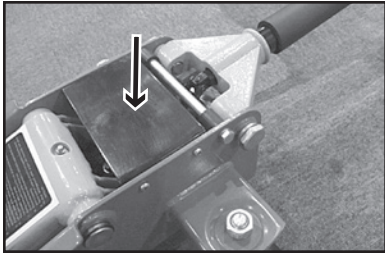

6.4 ADDING OIL

- 6.4.1 Fully retract the ram by turning the release valve counter-clockwise.
- 6.4.2 Loosen and take off the four top plate retaining screws and remove the top plate vertically as pictured below.

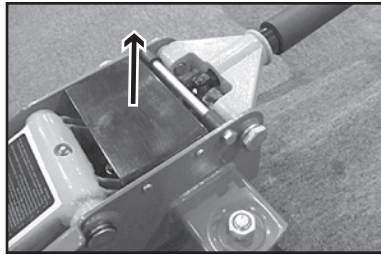
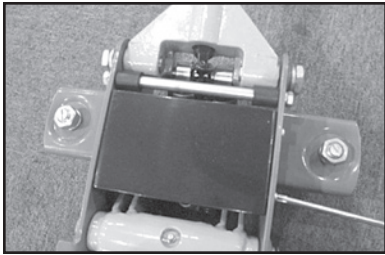

- 6.4.3 With the jack in the level position, remove the oil filler plug.

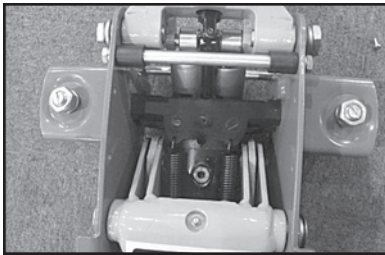

- 6.4.4 Fill with oil through the oil hole and make sure the oil surface level to the top of oil tank is less than 11 mm.

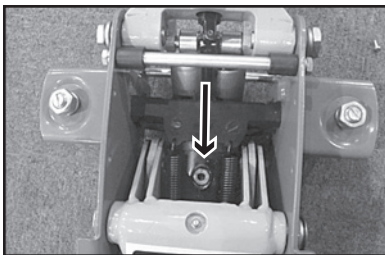



6.4.5 Replace the oil filler plug, purge air from the hydraulic unit as required. Refer to Section 4.

6.4.6 Replace the top plate and tighten the four screws.

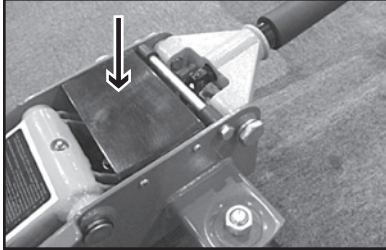

TROUBLESHOOTING

PROBLEM	CAUSE	REMEDY
Jack will not lift to full height	<ol style="list-style-type: none"> 1. Oil level low 2. Release valve not closing 	<ol style="list-style-type: none"> 1. Check / add oil 2. Close the release valve
Jack will not hold the load	<ol style="list-style-type: none"> 1. Release valve not closing 2. Hydraulic oil is contaminated 3. Pump leaking 	<ol style="list-style-type: none"> 1. Close the release valve 2. Contact authorized service agent
Lift arm will not lower	<ol style="list-style-type: none"> 1. Pump cylinder binding 2. Parts worn 3. Internal component damage 4. Return spring broken or unhooked 5. Lift arm linkage either bent or binding 6. Air in the hydraulic system 	<ol style="list-style-type: none"> 1. Contact authorized service agent
After hydraulic purging, the jack still can't reach the maximum by eight pumps	<ol style="list-style-type: none"> 1. Still have air in the hydraulic system 	<ol style="list-style-type: none"> 1. Purge air according to manual Part 4.5
Poor lift performance	<ol style="list-style-type: none"> 1. Fluid level low 2. Hydraulic unit malfunction 	<ol style="list-style-type: none"> 1. Ensure proper fluid level 2. Discontinue use, contact authorized service agent

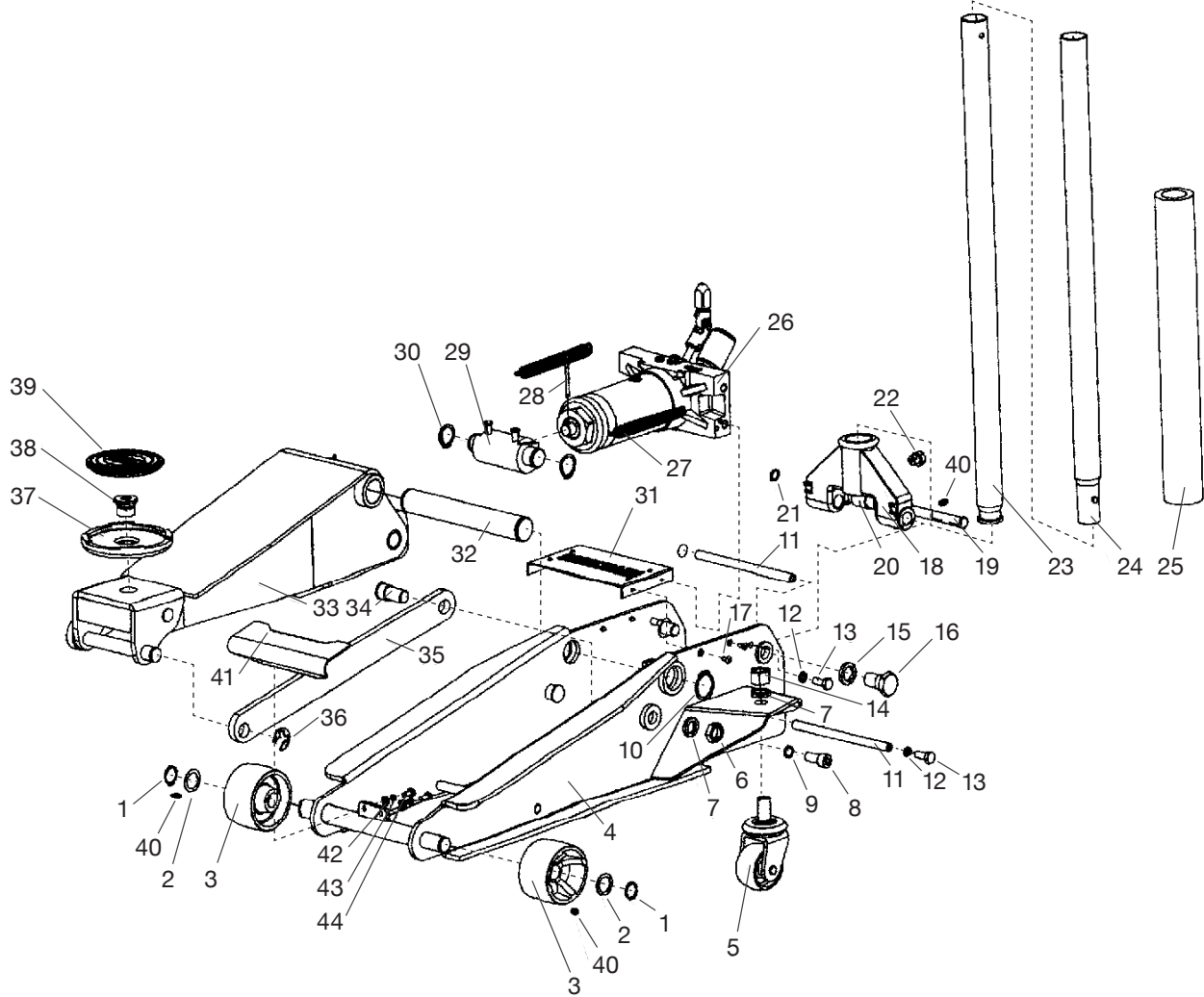

PARTS LIST: 3.5-TON SD FLOOR JACK — PARTS BREAKDOWN — Prod. No. 352SD

PART NUMBER	KIT DESCRIPTION	REF. #	KIT INCLUDES
352SD-24	Handle	24	Upper Handle
		23	Lower Handle
		25	Handle Protection
352SD-25	Handle Protection	25	Handle Protection
352SD-37	Saddle Complete	37	Saddle Complete
		38	Bolt
352SD-31	Cover	39	Saddle Pad
		31	Cover
352SD-5	Caster	5	Caster
		7	Washer
		14	Nut
		17	Screws Qty 4

PART NUMBER	KIT DESCRIPTION	REF. #	KIT INCLUDES
352SD-40	Oiler Bowl	40	Oiler Bowl
352SD-3	Wheel	3	Wheel
		2	Washer
		1	Retaining Ring
352SD-26	Hydraulic Unit	26	Hydraulic Unit
352SD-27	Spring	27	Spring
352SD-29	Push Rod	29	Push Rod
		30	Retainer Ring
352SD-22	Handle Screw	22	Handle Screw
352SD-50	Release Valve	50	Release Valve
352SD-RK	Repair Kit		Repair Kit

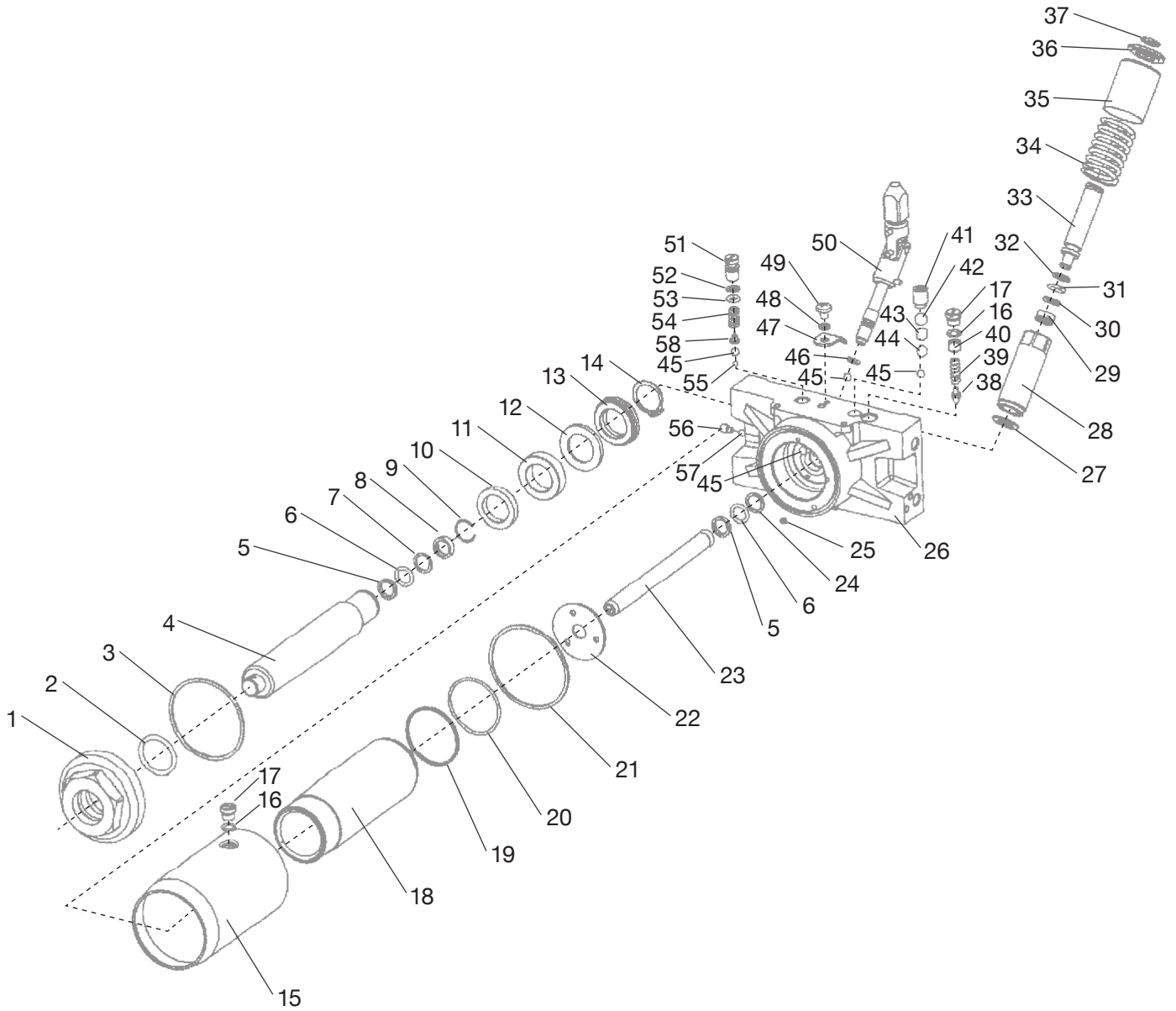



PARTS LIST: 3.5-TON SD FLOOR JACK — PARTS BREAKDOWN — PROD. NO. 352SD

PART NUMBER	KIT DESCRIPTION	REQ.	PART NUMBER	KIT DESCRIPTION	REQ.	PART NUMBER	KIT DESCRIPTION	REQ.
1	Tank Nut	1	21	Washer	1	41	Screw	1
2	O-Ring 36 x 3.5	1	22	Washer	1	42	Ball 10	1
3	Washer	1	23	Piston Rod	1	43	Separator	1
4	Ram	1	24	Washer	1	44	Ball 8	1
5	Backup Ring	2	25	Permanent Magnet	1	45	Ball 6	4
6	O-Ring 12.5 x 2.65	2	26	Valve Base	1	46	O-Ring 8 x 1.8	1
7	Backup Ring	1	27	Washer	1	47	Locker	1
8	Guide Ring	1	28	Pump Case	1	48	Spring Washer 6	1
9	Snap Ring 17	1	29	U-Seal	1	49	Screw	1
10	Spacer Ring	1	30	Backup Ring	1	50	Release Assembly	1
11	Guide Ring	1	31	O-Ring 10 x 2.65	1	51	Screw	1
12	Washer	1	32	Backup Ring	1	52	Backup Ring	1
13	U-Seal	1	33	Pump Core	1	53	O-Ring 6 x 2.65	1
14	Retaining Ring 25	1	34	Pressure Spring	1	54	Pressure Spring	1
15	Cylinder Outer Case	1	35	Pump Outer Case	1	55	Ball 4	1
16	O-Ring 8.5 x 1.8	2	36	Pump Cover	1	56	Screw M6 x 10	1
17	Screw	2	37	Snap Ring	1	57	Ball 5	1
18	Cylinder Outer Case	1	38	Safety Valve	1	58	Ball Saddle	1
19	Backup Ring	1	39	Relief Valve Spring	1			
20	O-Ring 46.2 x 2.2	1	40	Screw	1			



AMERICAN FORGE & FOUNDRY

LIMITED WARRANTY

SureWerx USA WARRANTS TO ITS CUSTOMERS THAT THE COMPANY'S SureWerx USA "AFF" BRANDED PRODUCTS ARE FREE FROM DEFECTS IN WORKMANSHIP AND MATERIALS.

SureWerx USA will repair or replace its **SureWerx USA "AFF"** branded products which fail to give satisfactory service due to defective workmanship or materials, based upon the terms and conditions of the following described warranty plans attributed to that specific product. This product carries a ONE-YEAR warranty. During this warranty period, **SureWerx USA** will repair or replace at our option any part or unit which proves to be defective in material or workmanship.

Other important warranty information:

This warranty does not cover damage to equipment or tools arising from alteration, abuse, misuse, damage and does not cover any repairs or replacement made by anyone other than **SureWerx USA**. The foregoing obligation is **SureWerx USA's** sole liability under this or any implied warranty and under no circumstances shall we be liable for any incidental or consequential damages.

Note: Some states do not allow the exclusion or limitation of incidental or consequential damages, so the above limitation or exclusion may not apply to you. If you have any questions about warranty service, please contact **SureWerx USA**. This warranty gives you specific legal rights and you may also have other rights which vary from state to state.

A



surewerx.com

SureWerx, USA Inc.,
325 Corporate Drive, Elgin, IL USA 60123
surewerx.com/usa
affjaxx.com
800-323-7402

520-INST-0922