

## **1/2 Ton High Lift Transmission Jack** *Owner's Manual*



### **WARNING:**

Read all instructions and safety warnings before operating this equipment. Failure to follow the instructions and safety warnings may result in personal injury or property damage.

## **WARNING!**

The use of shop equipment is subject to certain hazards that cannot be prevented by mechanical means, but only by exercise of intelligence, care, and common sense. It is therefore essential to have personnel involved in the use and operation of equipment who are careful, competent, trained, and qualified in the safe operation of this equipment and its proper use when servicing motor vehicles and their components. Examples of hazards are dropping, tipping, or slipping of motor vehicles or their components caused primarily by improperly securing loads, overloading, off-centered loads, use on other than hard level surfaces, and using equipment for a purpose for which it was not designed. Only Strongarm attachments and/or adapters may be used on this equipment.

The owner and/or operator shall study and understand the product and safety instructions before operating this equipment. Safety information shall be emphasized and understood. If the operator is not fluent in English, the product and safety instructions shall be read to and discussed with the operator in the operator's native language by the purchaser/owner or his designee, making sure that the operator comprehends their contents. A copy of these instructions/warnings shall be retained for future reference.

### **1. SERVICE/INSPECTION**

Visual inspection shall be performed before each use of this equipment and its adapters, checking for abnormal conditions, such as cracked welds, leaks, and damaged, loose or missing parts. This equipment shall be removed immediately from service if it is believed to have been subjected to an abnormal or shock load and shall be inspected by a qualified repair facility. Owners and/or operators should be aware that repair of this equipment may require specialized knowledge and facilities. It is recommended that this equipment be inspected annually by a qualified repair facility. Defective parts, decals, safety labels or signs should be replaced with Strongarm specified parts.

## **WARNING!**

- The technician using this jack must be trained, qualified, fully familiar with safe work practices, and have prior experience in the use of hydraulic equipment. Lack of knowledge in any of these areas can lead to equipment damage and/or personal injury.
- Read, understand, and follow all instructions before operating this jack.
- Inspect the jack before each use. Do not use jack if damaged, altered, modified, leaking hydraulic fluid or with missing or loose components.
- Never modify or weld hydraulic equipment.
- Never lift more than the rated capacity of the jack: overloading causes equipment failure and possible personal injury.
- The jack is a load lifting device, not a load holding device. Once the load is raised, it must always be firmly supported with auxiliary stands. Never work under or around a load supported only by hydraulic devices.
- Never put unbalanced or off-centre loads on the jack saddle. Use saddle adapters and saddle extenders along with straps and chains to secure load to the saddle head. Incorrect loading can result in equipment failure.
- This jack was designed for lifting transmissions only. Consult the vehicle manufacturer for the transmission's centre of balance.
- Secure the transmission to the jack's saddle with the anchorage restraint system provided before raising or lowering the transmission.
- Use of this product is limited to the removal, installation and transportation in the lowered position. Jack should only be used on a flat, clean, unobstructed concrete floor.
- Always wear safety glasses and/or other protective equipment that meet or exceed ANSI Z87.1 and OSHA standards.
- Use the jack ONLY on hard, level surfaces capable of sustaining the load.

## **SETUP**

Visually inspect all components for shipping damage. If any shipping damage is found, notify carrier at once. Shipping damage is NOT covered by warranty. The carrier is responsible for all repair or replacement cost resulting from damage in shipment.

- 1 Take out all the parts from the wooden box.
- 2 Connect 4 casters (44) with Base Assembly (40) by using Nut (41), Lock Washer (42) and Flat Washer (43).
- 3 Connect Adaptor (48) with the piston of the pump.
- 4 Attach 4 Safety Pieces (S02) to the adaptor (S03) by using Bolt (S01), Washer (S04) and Wing Nut (S05).
- 5 Connect Chain (S26) with Plate (S03) by using Bolt (S27), Washer (S25) and Nut (S24).
- 6 Attach Hook (S06) with Base by Using Wing Nut (S08). And then connect the whole assembly with the plate (S03) by using Washer (S22) and Nut (S23).

## operation

### WARNING!

Ensure that you read, understand and apply the safety instructions and warnings before use. Failure to heed these instructions may result in property damage and/or personal injury.

1. Roll the transmission jack into position and pump the foot pedal (35) until saddle reaches desired height.

**NOTE: Follow vehicle manufacturer's recommended procedures for removing the load as outlined in vehicle service manual or repair guide.**

2. Carefully center load on the saddle. Ensure the load's center of gravity is centered on the saddle and the setup is stable and secure.

**NOTE: Before lowering load check to ensure all tools and personnel are clear and it is safe to lower the load.**

3. SLOWLY and CAREFULLY operate the release pedal 32 to lower the load to its lowest possible position.
4. If necessary, CAREFULLY and SLOWLY move the jack.
5. Transfer load immediately to appropriate support device for service or repair.



## MAINTENANCE

1. When not in use, store the jack in a dry location with saddle in lowest position.
2. Periodically check the piston rod for signs of rust or corrosion. Clean exposed areas with a clean oiled cloth.

**Warning: Never use sandpaper or abrasive material on these surfaces!**

3. A coating of light lubricating oil to pivot points, axles and hinges will help to prevent rust and assure that castors, foot pedal and pump assemblies move freely. Periodically lubricate the pivot points, axles and hinges with a light lubricating oil as needed.
4. With jack in its lowest position, remove the air vent screw (25) to check the hydraulic oil level. If it is not adequate, add high quality hydraulic jack oil as necessary. Insert and tighten the air vent screw. Then purge away air from hydraulic system as described in purging.

**Warning: DO NOT use brake fluid or any other improper fluid and avoid mixing different types of oil when adding hydraulic oil.**

5. To ensure best performance and longer equipment life, replace the complete hydraulic oil at least once a year. With jack in its lowest position, remove the air vent screw (25), lay the jack on its side and drain the oil into a suitable container. Ensure that no dirt gets into the system. Set the jack in its level upright position, fill with approved hydraulic jack oil. Then replace the air vent screw (25) and purge away air from hydraulic system as described in purging air.

**Note: Dispose of hydraulic oil in accordance with local regulations.**

6. When equipment efficiency drops, purge away air from hydraulic system.
7. It is recommended that an annual inspection be done by qualified technicians.

## PURGING AIR FROM THE HYDRAULIC SYSTEM.

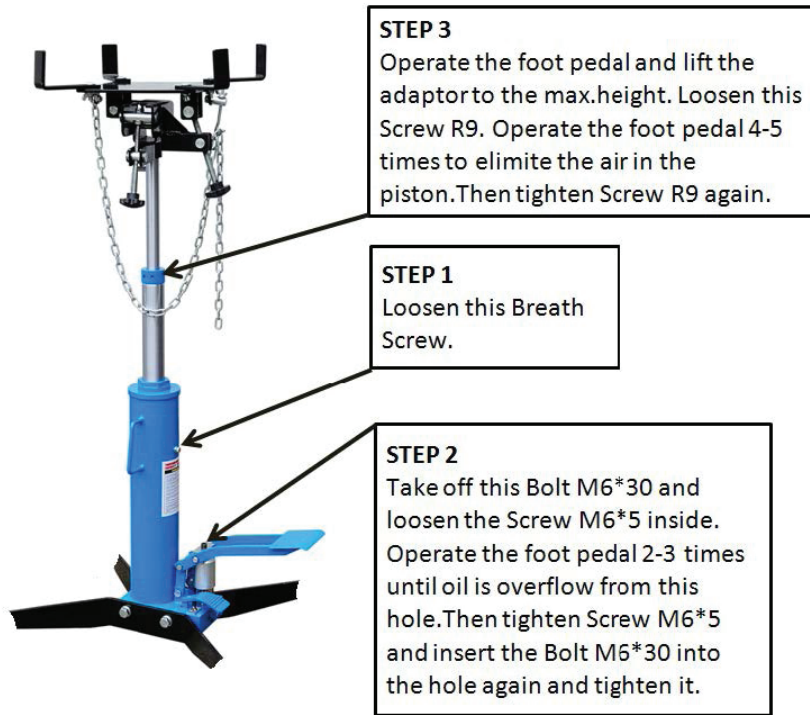

## ! TROUBLE SHOOTING GUIDE

Trouble	Cause	Solution
Unit fails to extend or extends partially	1.Low fluid level	1.Refer to maintenance section and fill to correct fluid level
Incomplete or spongy cylinder response when foot pedal is pumped	1.Low fluid level	1.Fill to correct fluid level
	2.Air in system	2.Follow Purge Air in the hydraulic system.
	3.Pressure is low	3.Pressure regulating again
Unit fails to extend when foot pedal is pumped	1. Release the jack.	1.Operate the foot pedal and release pedal together.
	2.Contamination	2.Disassemble and clean unit

**!** PARTS

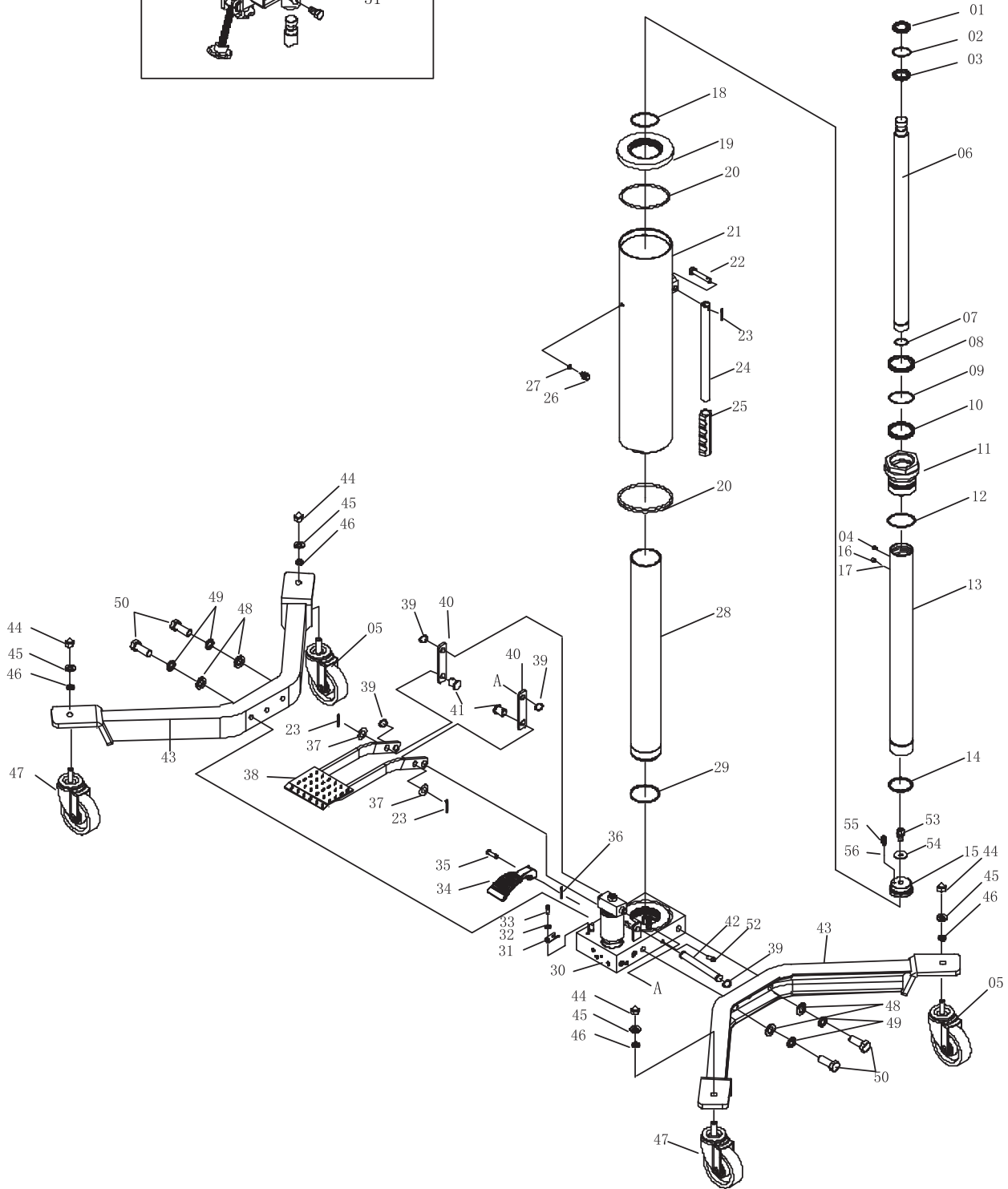
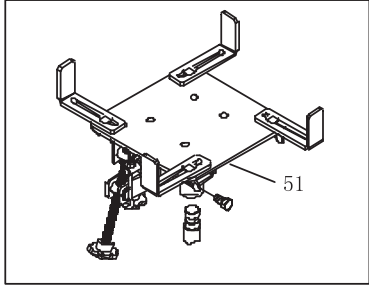



## PARTS LIST

Parts No.	Description	Qty	Parts No.	Description	Qty
1	Dust ring	1	29	Washer	1
2	O-ring	1	30	Pump	1
3	U-ring	1	31	U-limited	1
4	Oil cup	1	32	Lock washer	1
5	Caster	2	33	Screw	1
6	Second piston rod	1	34	Release pedal	1
7	Retainer ring	1	35	Pin	1
8	Dust ring	1	36	Cotter pin	1
9	O-ring	1	37	Washer	2
10	U-ring	1	38	Foot pedal	1
11	Round nut	1	39	Retainer ring	4
12	O-ring	1	40	Connect rod	2
13	First piston rod	1	41	Pin	2
14	Limited ring	1	42	Pin	1
15	Plunger	1	43	Legs	2
16	Screw	1	44	Nut	4
17	Steel	1	45	Lock washer	4
18	O-ring	1	46	Washer	4
19	Round nut base	1	47	Caster with brake	2
20	Washer	2	48	Washer	4
21	Oil tank	1	49	Lock washer	4
22	Pin	1	50	Bolt	4
23	Cotter pin	3	51	Saddle	1
24	Handle	1	52	Screw	2
25	Handle cover	1	53	Second Limited valve	1
26	Exhaust screw	1	54	Washer	1
27	Seal ring	1	55	Spring	1
28	Ram	1	56	Steel ball	1

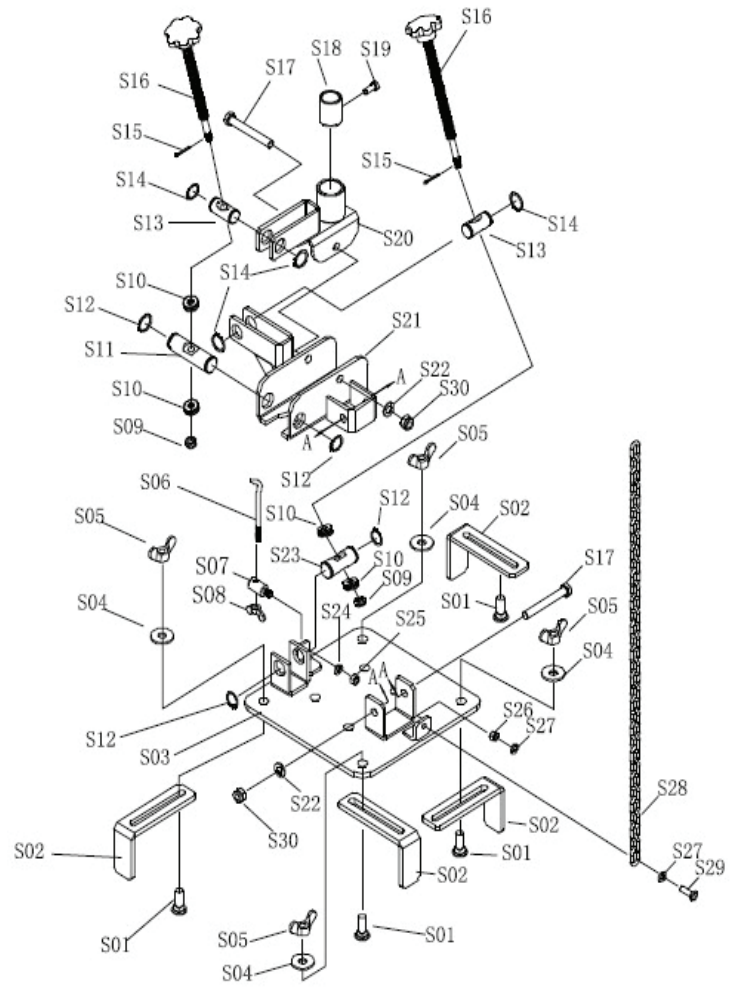
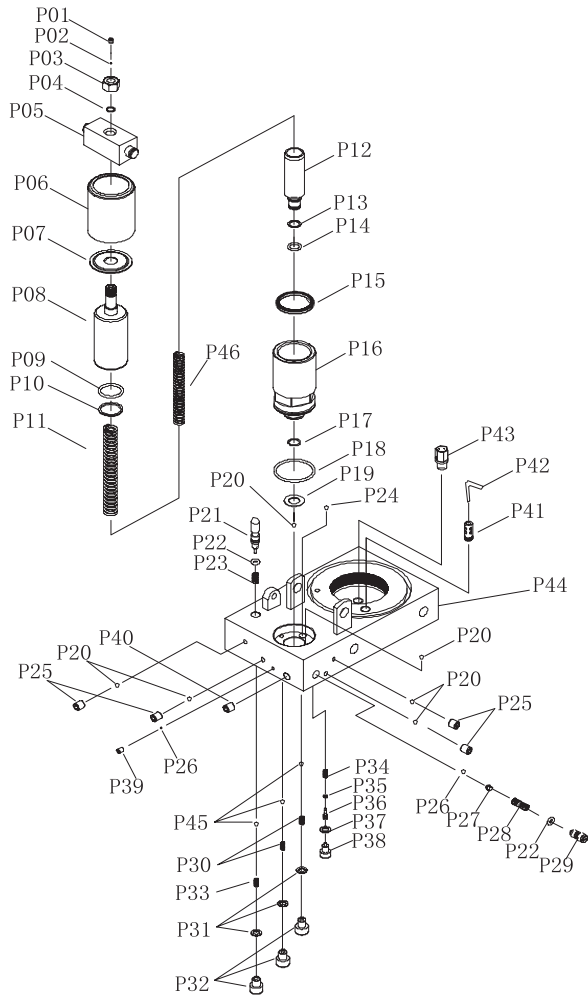

Parts No.	Description	Qty	Parts No.	Description	Qty
S01	Bolt	4	S16	AdjustedHandle	2
S02	Block	4	S17	Bolt	2
S03	Plate	1	S18	Cover	1
S04	Washer	4	S19	Bolt	1
S05	Nut	4	S20	Saddle Base	1
S06	Chain Hook	1	S21	PlateCarrier	1
S07	Hook Base	1	S22	Washer	2
S08	Nut	1	S23	Pin2	1
S09	Nut	2	S24	Washer	1
S10	Bear	4	S25	Nut	1
S11	Pin	1	S26	Nut	1
S12	Retainer Ring	4	S27	Washer	2
S13	Pin1	2	S28	Chain	1
S14	Retainer Ring	4	S29	Bolt	1
S15	Cotter Pin	2	S30	Nut	2

Parts No.	Parts No.	Qty	Parts No	Description	Qty
P2	Steel Ball	1	P25	Screw	4
P3	Nut	1	P26	Steel Ball	2
P4	O-Ring	1	P27	Steel Ball Base	1
P5	Pin Cover	1	P28	Spring	1
P6	Dust Cover	1	P29	Screw	1
P7	Dust Plunger	1	P30	Spring	2
P8	Big Pump Core	1	P31	Washer	3
P9	O-Ring	1	P32	Screw	3
P10	Washer	1	P33	Spring	1
P11	Spring	1	P34	Spring	1
P12	Small Pump Core	1	P35	O-Ring	1
P13	Washer	1	P36	Push Rod	1
P14	O-Ring	1	P37	Copper Washer	1
P15	U-Ring	1	P38	Screw	1
P16	Pump Core Base	1	P39	Screw	1
P17	Retainer Ring	1	P40	Screw	1
P18	O-Ring	1	P41	Connector	1
P19	Smal Copper Washer	1	P42	Filter	1
P20	Steel Ball	6	P43	First Limited Valve	1
P21	Release Valve Core	1	P44	Pump	1
P22	O-Ring	2	P45	Steel Ball	3
P23	Spring	1	P46	Spring	1