

Installation / Operating / Maintenance Instructions

Regulator

Prod. No. 408817, 408818, 408821, 408823, 408825

Specifications

Model	ARM18	ARM14	ARI14	ARI38	ARS12
Port size	1/8, 1/4, 3/8, 1/2				
Pressure gauge port size	1/8				
Max. supply pressure	220 psi (15 bar)				
Set pressure	Refer to product nameplate				
Installation	Any position				
Medium	Compressed air - Filtered				
Ambient / media temperature	5° - 60° C (41° - 140° F)				

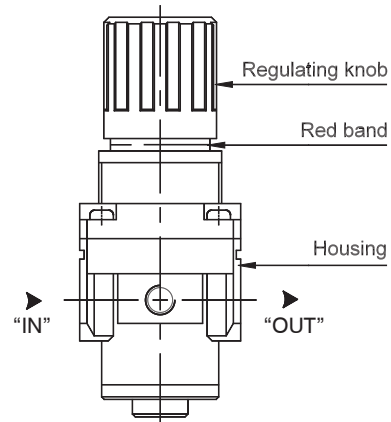

fig. 1

Important

Since this equipment is used in compressed air line, proper precautions are to be taken for safety.

Installation Instruction

1. Install in a clean / acid free environment.
2. Before installation of the unit, check whether the unit is as per the specification - especially the port size and the corresponding fittings to be used on the unit.
3. Flush the piping for dirt, dust, rust and other foreign particles.
4. The arrow mark ► on the top of the housing indicates the flow direction, Inlet ► Outlet (If the unit is connected in the reverse direction air will continuously flow through the knob and the setting of pressure is not possible.)
5. Use proper thread seals for (R) taper thread nipple, or face washer for (G) parallel thread nipple.
6. Tighten the piping / nipples to the housing ports using proper tools. Do not over torque when tightening.
7. When using (G) parallel thread nipples, check the length of the thread.

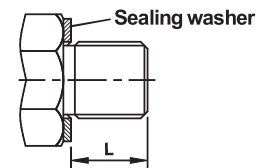

Thread Size	Tightening torque, Lb / in (Nm)	Length (L) of thread
G1/4	106 - 125 (12 - 14)	8mm Max.
G3/8	195 - 215 (22 - 24)	9mm Max.
G1/2	250 - 270 (28 - 30)	12mm Max.



Length of G parallel thread

8. Ensure foreign particles / tape, etc. do not enter the valve during assembly.

Operating Instructions

1. To set the Regulator, pull the regulating knob till "Red Band" (Indicator ring) is visible (refer to figure 1).
2. To increase the pressure turn the regulating knob in clockwise direction  (see the marking on the knob)
3. To reduce the pressure turn the regulating knob in counter clockwise direction 
4. Always set the pressure in an ascending manner.
5. Set the pressure within the specified set pressure.

Maintenance Instructions

- a. Before dismantling the unit, exhaust the air in the line completely.
 - b. Dismantle the components and clean them in kerosene and blow with compressed air.
1. Check for damages in the 'O' rings (15), (16.1), (17) and at sealing areas in the valve cone rubber, spherical relieving seating, seating area of the housing, etc. Replace if needed (or) clean and reassemble.
- d. For assembly of the unit:
 - apply NLGI Grade 2 grease on the 'O' rings (15), (16.1), (17) and on the cylindrical surface of the valve cone (13), on threads of the adjusting screw (7), and on bearing washer (6).
 - Reassemble all the components.

Assembly / Spare Parts List

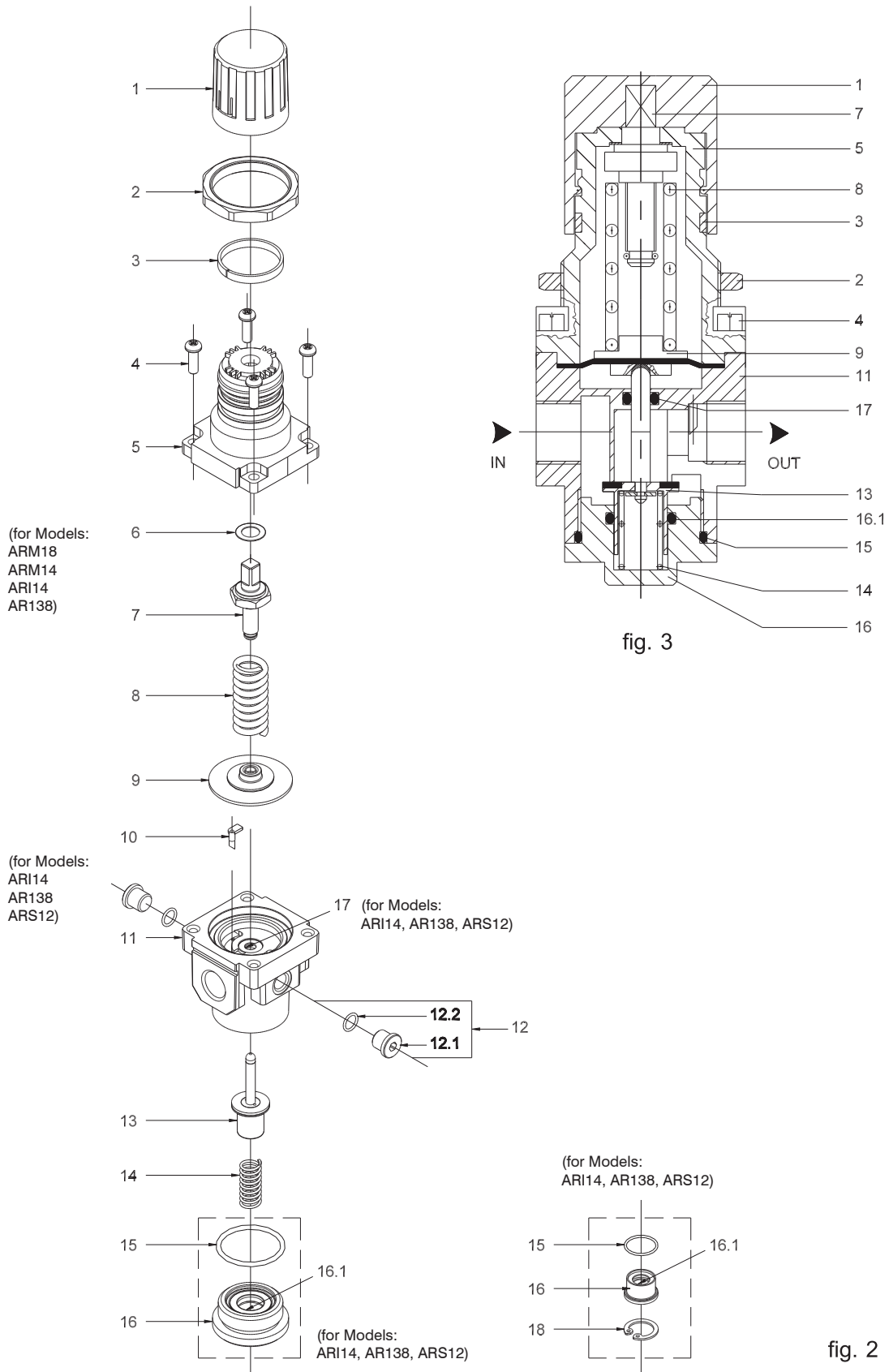

fig. 3

fig. 2

Spare Parts List Regulator

Ref. No.	No. off.	Part name	Ordering No. for		
			ARM18 / ARM14	ARI14 / ARI38	ARS12
1	1	Knob	-		
2	1	Locknut	-	-	-
3	1	Indicator ring	-	-	-
4	4	Philip head screw	-	-	-
5	1	Bonnet	-	-	-
6	1	Bearing washer	-	-	-
7	1	Adjusting screw assembly	LA2200	LA2201	LA2202
8	1	Main spring	*	*	*
*	*	0.2 - 2 bar	062025	062031	062061
*	*	0.2 - 4 bar	062026	062032	062062
*	*	0.5 - 7 bar	062027	062033	062063
*	*	0.5 - 10 bar	062028	062030	062060
9	1	Diaphragm assembly	SA2200	SA2201	SA2202
10	1	Venturi tube	NIL	-	-
11	1	Housing	-	-	-
12	2	Port plug assembly	LA2203	LA2203	LA2203
12.1	2	Port plug	-	-	-
12.2	2	'O' ring	651004	651004	651004
13	1	Valve cone assembly	SA2207	SA2203	SA2204
14	1	Bottom spring	-	-	-
15	1	'O' ring	650009	650106	650107
16	1	Bottom plug	-	-	-
16.1	1	'O' ring	650004	650104	650105
17	1	'O' ring	NIL	650100	650100
18	1	Circlip	-	NIL	NIL

	Denotes for ordering items. For example, Valve cone assembly the item will be supplied as kit, consisting of Valve cone, 'O' ring (15), 'O' ring (16.1) 'O' ring (17) accordingly.
--	---

Trouble shooting

Trouble	Causes	Solution
1. Continuous leak through the knob (1)	<ol style="list-style-type: none"> 1. Diaphragm (9) damaged. 2. Relieving spherical seating of the valve cone damaged. 3. Dirt found in between the seating and the valve cone (13) 4. 'O'ring (16.1) damaged. 	<ol style="list-style-type: none"> 1. Replace diaphragm assembly (9) 2. Replace valve cone assembly (13) 3. Clean and reassemble. 4. Replace the 'O'ring (16.1).
2. Setting pressure goes on increasing slowly	<ol style="list-style-type: none"> 1. Relieving spherical seat of the valve cone damaged. 2. Dirt found in between the seating and the valve cone. 3. 'O'ring (16.1) damaged 	<ol style="list-style-type: none"> 1. Replace the valve cone assembly (13) and clean the seating area 2. Clean and reassemble 3. Replace 'O'ring (16.1).
3. After frequent use of adjustment, the pressure setting becomes not possible	Wearing out of the Adjusting screw (7)	Replace the Adjusting screw assembly after applying general purpose Grease on threads and at bearing washer (6).
4. Supply pressure directly connected to outlet port and pressure setting not possible.	Valve cone (13) got stuck	Dismantle the valve cone (13). Clean using Kerosene and air. Reassemble after applying general purpose grease on 'O'ring (17) [as applicable to the model] and on the valve cone cylindrical portion
<p>Remarks: When the unit is installed in a salty atmosphere, there is a good chance of formation of Aluminum Oxide inside the housing and the bottom plug (16). This may cause the valve cone to get stuck. In this case dismantle the components and clean them using kerosene and air. During reassembly apply general purpose grease on all the inside surfaces of the housing and bottom plug as protection against corrosion. Also apply grease on the 'O' rings and cylindrical portion of the valve cone.</p>		

How to order spare parts:

Mention the spare parts and model numbers as given in the tables.

Example: 'O' ring 650106 for ARM18

Subject to change

Pour l'information en français, visitez notre site Web : www.jetequipment.com/fr/