

AW19CSDP 3/4"DR IMPACT WRENCH PRODUCT # 400340

For maximum performance we recommend 90 – 120 PSI air pressure

NOT SHOWN

PBIAW19CSD104 SOCKET RETAINER

PBIAW19CSD105 O - RING

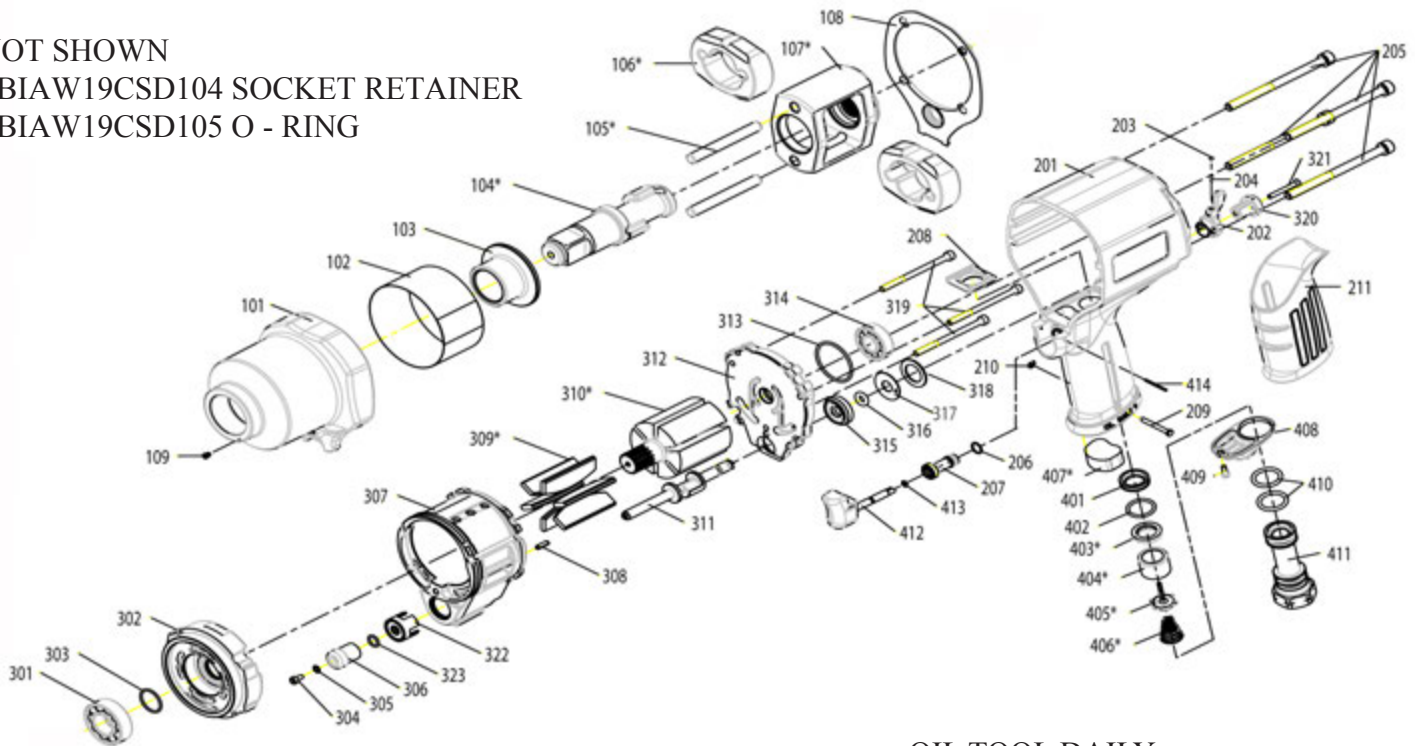

OIL TOOL DAILY

REF	PART NUMBER	DESCRIPTION	REQ	REF	PART NUMBER	DESCRIPTION	REQ	REF	PART NUMBER	DESCRIPTION	REQ
101	PBIAW19CSDP-101	HAMMER CASE	1	211	PBIAW19CSDP-211	HANDLE GRIP	1	319	PBIAW19CSDP-319	HEX.SOC.HD.BOLT	1
102	PBIAW19CSDP-102	STEEL RING	1	301	PBIAW19CSD301	BEARING	1	320	PBIAW19CSDP-320	SPRING B	1
103	PBIAW19CSD103	HAMMER CASE BUSHING	1	302	PBIAW19CSDP-302	FRONT BRG PLATE	1	321	PBIAW19CSDP-321	SCREW	1
104	PBIAW19CSDP-104	ANVIL UNIT	1	303	PBIAW19CSDP-303	O - RING	1	322	PBIAW19CSDP-322	LATCH SP BUSHING	1
105	PBIAW19CSDP-105	HAMMER PIN	2	304	PBIAW19CSDP-304	HEX.SOC.HD.BOLT	1	323	PBIAW19CSDP-323	O - RING	1
106	PBIAW19CSD108	HAMMER	2	305	PBIAW19CSDP-305	FLAT WASHER	1	401	PBIAW19CSD401	INSERT BUSHING	1
107	PBIAW19CSD109	HAMMER FRAME	1	306	PBIAW19CSDP-306	SPRING A	1	402	PBIAW19CSD402	O - RING	1
108	PBIAW19CSDP-108	HAMMER CASE GASKET	1	307	PBIAW19CSDP-307	CYLINDER UNIT	1	403	PBIAW19CSDP-403	SEAL UNIT	1
109	PBIAW19CSDP-109	HAMMER CASE GR FTG	1	308	PBIAW19CSDP-308	SPIRAL PINS	1	404	PBIAW19CSDP-404	BUSHING	1
201	PBIAW19CSDP-201	HOUSING	1	309	PBIAW19CSD305	BLADES	6	405	PBIAW19CSD405	TIP VALVE	1
202	PBIAW19CSDP-202	REGULATOR	1	310	PBIAW19CSDP-310	ROTOR	1	406	PBIAW19CSD406	SPRING	1
203	PBIAW19CSD311	BALL	1	311	PBIAW19CSDP-311	REVERSE VALVE	1	407	PBIAW19CSD407	MUFFLER	1
204	PBIAW19CSDP-204	POSITIONING SPRING	1	312	PBIAW19CSDP-312	REAR END PLATE	1	408	PBIAW19CSD408	DEFLECTOR	1
205	PBIAW19CSDP-205	BOLT W/FLAT WASHER	4	313	PBIAW19CSDP-313	O - RING	1	409	PBIAW19CSD409	TAP BOLT	1
206	PBIAW19CSD414	O - RING	1	314	PBIAW19CSDP-314	BEARING	1	410	PBIAW19CSD410	O - RING	2
207	PBIAW19CSDP-207	TRIGGER BUSHING B	1	315	PBIAW19CSDP-315	LATCH SP BUSHING	1	411	PBIAW19CSD411	AIR INLET	1
208	PBIAW19CSDP-208	SEAL	1	316	PBIAW19CSDP-316	O - RING	1	412	PBIAW19CSDP-412	TRIGGER UNIT	1
209	PBIAW19CSDP-209	LATCH PIN	1	317	PBIAW19CSDP-317	FLAT WASHER	1	413	PBIAW19CSDP-413	O - RING	1
210	PBIAW19CSDP-210	E - RING	1	318	PBIAW19CSDP-318	SEAL	1	414	PBIAW19CSDP-414	SPRING PIN	1