



PROD NO. 028017  
MOD NO. IBG-8

# 3/4 HP 8" Bench Grinder *Owner's Manual*



## **WARNING:**

**Read all instructions and safety warnings before operating this equipment. Failure to follow the instructions and safety warnings may result in personal injury or property damage.**

# TABLE OF CONTENTS

---

SPECIFICATIONS..... 2  
IMPORTANT SAFETY RULES..... 3  
KNOW YOUR BENCH GRINDER ..... 4  
OPERATING INSTRUCTIONS ..... 5  
MAINTENANCE..... 11  
TROUBLESHOOTING ..... 12, 13  
EXPLODED VIEW AND PARTS LIST..... 14, 15  
WARRANTY ..... 16

# SPECIFICATIONS

---

Product No.: 028017 • Model No.: IBG-8

Serial #:

Motor Type:..... Induction

Motor Ratings: ..... 120 V AC, 4.8 A, 60 Hz

Horsepower: .....3/4 HP

Wheel Diameter: ..... 8" (20.32 cm)

Wheel Width: .....1" (25.4 mm)

Arbor Hole Diameter: ..... 5/8" (18.875 mm)

No load Speed:..... 3,450 RPM

Wheel Grits: ..... 36 (Coarse), 60 (Medium)

Work light Bulb:..... Max 40W anti-vibration light bulb

## IMPORTANT SAFETY RULES

---

**DANGER!** Failure to observe any of the following instructions could result in severe personal injury to tool user and bystanders or cause damage to tool and property!

**WARNING!** Read, understand and observe all instructions in this manual before using or operating the tool for which it is written and supplied. Ensure that anyone who is to use the tool as read and understood the instructions provided.

- **Always** wear eye protection that complies with a recognized standard (CSA or ANSI).
- Wear a mask or respirator when dust is generated.
- Keep bystanders out of the work area while operating the tool.
- **WARNING! Always ensure that the work area is clear of any flammable materials, liquids or gasses, because the use of this tool may create sparks.**
- Tighten grinding wheel lock nuts, securing bolts and all clamps and guards.
- During each start-up, stand to one side of the grinder and switch it 'On'. Let the grinder operate at full speed for approximately one minute, so that any undetected flaws or cracks will become apparent.
- Keep guards in place and working properly.
- Keep hands clear of grinding wheels.
- **Never** reach behind or beneath the grinding wheels.
- Unplug from power supply before adjusting or servicing. The grinding wheels continue to rotate after the tool is switched off. Always allow wheels to stop before adjusting or servicing.
- To avoid electric shock, **DO NOT** use in damp conditions or expose to rain.
- When fitting a new grinding wheel, **always** check that the stated maximum RPM meets or exceeds that stated on the grinder. Also check the new wheel for damage, such as flaws or cracks. If the wheel appears satisfactory, fit it to the grinder.
- Use only accessories that are recommended by the manufacturer for your model.
- **DO NOT** attempt to cut anything with the grinding wheel.
- Grounded tools must be plugged into an outlet that has been properly installed and grounded in accordance with all local codes and ordinances. Never remove the grounding prong from the plug or modify it in any way. Do not use adaptor plugs. If in doubt as to whether the outlet is properly grounded, consult a qualified electrician.
- Do not use the tool when tired or under the influence of drugs, alcohol or medication.
- Do not wear loose clothing or jewelry. Keep hair tied back.
- Ensure the power switch is off prior to plugging in the tool.
  
- **WARNING! Replace cracked grinding wheels immediately.**
- **Do not overtighten spindle nuts.**
- **Adjust tool rests whenever necessary to maintain a distance of 1/8" (3.2 mm) from the grinding wheel.**
  
- Service on these tools should only be performed by an authorized, qualified technician.

# KNOW YOUR GRINDER

---

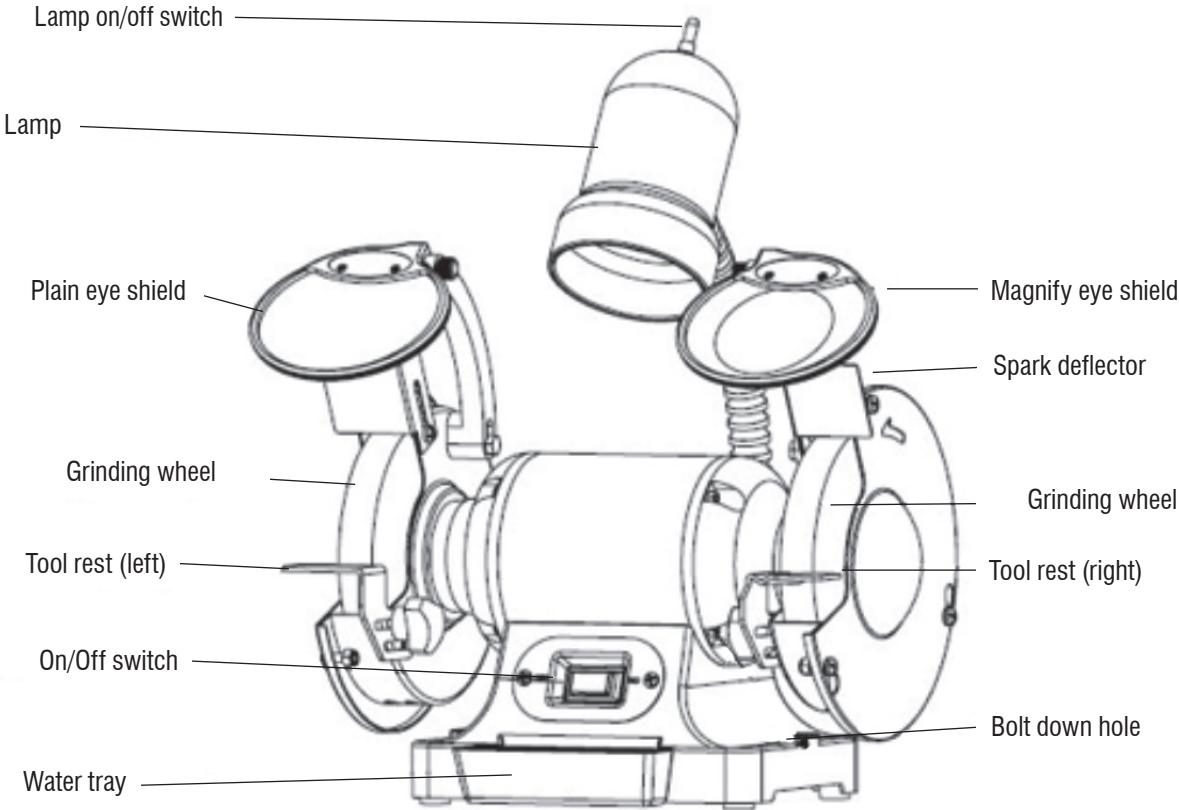

# OPERATING INSTRUCTIONS

---

## Before You Start - Safety

- **Always** wear eye protection that complies with a recognized standard (for example: ANSI Z87.1) - (CSA or ANSI).
- Wear a mask or respirator when dust is generated.
- Keep bystanders out of the work area while operating the tool.
- **WARNING! Always ensure that the work area is clear of any flammable materials, liquids or gasses, because the use of this tool may create sparks.**
- Do not wear loose clothing or jewelry. Keep hair tied back.
- **WARNING! Replace cracked grinding wheels immediately.**
- **Do not overtighten spindle nuts.**
- **Adjust tool rests whenever necessary to maintain a distance of 1/8" (3.2 mm) from the grinding wheel.**
- NEVER grind on the side of the wheel. Grind on the face of the wheel only.
- NEVER apply pressure to the workpiece when the grinding wheel is cold. Allow the wheel to warm up by applying the workpiece gradually.
- NEVER use the grinder without the wheel guards. Keep thumbs and fingers away from the wheel.

## Before You Start – Electrical

In the event of a malfunction or short circuit, grounding provides the path of least resistance for electrical current, and reduces the risk of electric shock for the operator. This tool is equipped with an electric cord that has an equipment grounding conductor and a grounding plug. The plug **MUST** be plugged into a matching outlet that is properly installed and grounded in accordance with ALL local codes and ordinances.

DO NOT MODIFY THE PLUG PROVIDED. If it will not fit the outlet, have the proper outlet installed by an electrician.

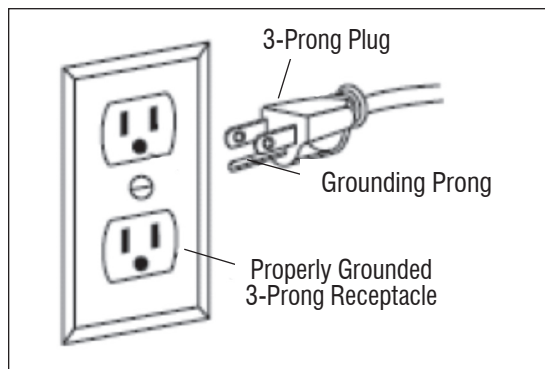

*Figure 2*

**IMPROPER CONNECTION** of the equipment grounding conductor can result in increased risk of electric shock. The conductor with the green insulation (with or without yellow stripes) is the equipment grounding conductor. If repair or replacement of the electric cord or plug is necessary, **DO NOT** connect the equipment grounding conductor to a live terminal.

**CHECK** with a qualified electrician or service personnel if you do not completely understand the grounding instructions, or if you are not sure if the tool is properly grounded.

This tool is intended for use on a circuit that has an outlet that looks like the one illustrated. The original tool has a grounding plug that looks like the plug illustrated (*Figure 2*).

## USE OF EXTENSION CORDS

---

**USE ONLY THREE-WIRED EXTENSION CORDS** that have 3-pronged plugs and 3-holed outlets that accept the tool's plug. Repair or replace damaged or worn cords immediately.

Be sure your extension cord is properly wired and in good condition. Do not use damaged extension cords. Always replace a damaged extension cord.

When using an extension cord, be sure to use one heavy enough to carry the current your product will draw. An undersized cord will cause a drop in line voltage, resulting in loss of power and overheating. The table below shows the correct size to use according to the cord length and the amperage draw of the tool (specified on the nameplate). When in doubt, use the next heavier gauge. The smaller the gauge number, the heavier the cord. (AWG = American Wire Gauge).

**Minimum Gauge for Extension Cords (AWG) (when using 120 volts only)**

Ampere Rating		Total Length of Cord in Feet (meters)			
More Than	Not more Than	25' (7.6 m)	50' (15 m)	100' (30.4 m)	150' (45.7 m)
0	6	18	16	16	14
6	10	18	16	14	12
10	12	16	16	14	12
12	16	14	12	<b>Not Recommended</b>	

Use a separate electrical circuit for your tools. This circuit should not be less than a #12 gauge wire, and should be protected with a 15 A time-lag fuse. Before connecting the motor to the power line, ensure the switch is in the OFF position and the electric current is rated the same as the current stamped on the motor's nameplate. Running at a lower voltage will damage the motor and is not covered by warranty.

## BEFORE YOU START – PACKAGE CONTENTS

---

Left work rest.....	1
Right work rest .....	1
Plain eye shield .....	1
Magnifying eye shield .....	1
Eye shield fixing knob .....	2
Eye shield mounting rod – one left, one right.....	2
Eye shield assembly mounting bolt M6x30 .....	2
Eye shield assembly mounting washer D6 .....	2
Eye shield assembly mounting locking washer D6.....	2
Work rest fixing knob.....	2
Work rest fixing pain washer D5 .....	2
Work rest fixing lock washer D5 .....	2
Coolant tray .....	1
Spark deflector.....	2
Spark deflector fixing screw assembly .....	2

# BEFORE YOU START – ASSEMBLY AND INSTALLATION

---

## Mounting the Grinder to the Workbench

Before attempting to use this grinder, it must be properly mounted to a workbench or grinding stand.

**CAUTION! Bench grinders vibrate. Grinder movement during high-speed rotation may cause injury or damage to the workpiece or operator. Mount the grinder securely to a sturdy workbench or grinding stand.**

1. Position the grinder on the workbench.
2. Mark the workbench through the two mounting holes located in the grinder base.
3. Drill holes in the workbench at the marks.
4. Using two long bolts, washers, lock-washers and nuts, as shown (not supplied), secure the grinder to the workbench.

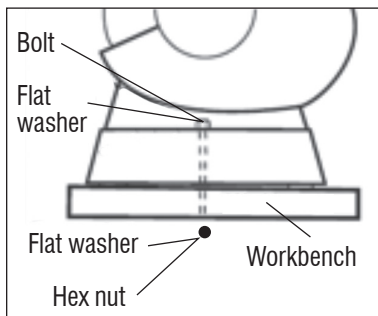

## Eye Shield Installation

Eye shields must be installed before operating the bench grinder.

1. Mount the left and right shield rods to the inside of the wheel guards using hex bolts.

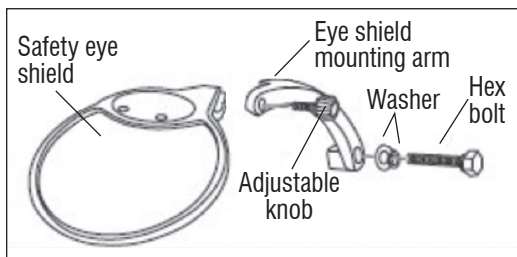

2. Once shield rods are firmly in place, slide the shield bracket onto the shield rod.

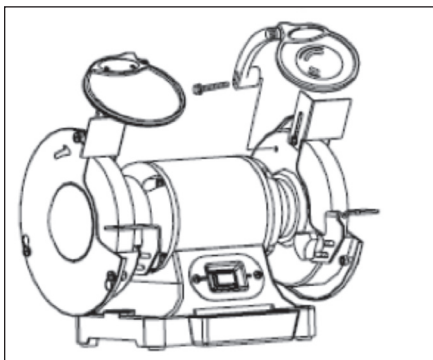

3. Tighten the carriage bolt, leaving it loose enough to allow the safety shield to be raised and lowered easily

**NOTE:** The eye shield should move freely when being adjusted, but stay in place when the locking knob is tightened.

**WARNING!** Turn the power off and remove the plug from the outlet before changing the grinding wheels. When turning the grinder on with a newly installed wheel, **DO NOT STAND IN FRONT OF THE GRINDER.** Stand to the side and allow the grinder to run for at least one minute before proceeding to use it.

## **INSTALLING OR CHANGING THE WHEEL**

---

1. Use a screwdriver to loosen the wheel cover screws and push anti-clockwise to remove the wheel cover.
2. Fit an appropriately sized wrench on the spindle hex nut.
3. Loosen the wheel nut in a clockwise direction for the left side and a counter-clockwise direction for the right side.
4. Remove the outer flange and grinding wheel. To remove the hex nut, turn the wrench and nut until the wrench is resting on the workbench behind the tool.
5. Inspect the new wheel carefully to ensure there are no cracks, chips or other damage.
6. Wipe the flange surfaces clean, and install the new wheel, flange and the spindle hex nut.
7. To install a new grinding wheel, reverse the above procedure.
8. Be sure the grinding wheel and outer flange are properly seated on the spindle shaft.
9. Replace the wheel cover and reposition the tool rest.

**When turning the grinder on with a newly installed wheel, DO NOT STAND IN FRONT OF THE GRINDER. Stand to the side and allow the grinder to run for at least one minute before proceeding to use it.**

**IMPORTANT!** Do not overtighten the spindle hex nut, because this may cause the wheel to crack.

**CAUTION! DO NOT INSTALL OR USE A DAMAGED GRINDING WHEEL.**

The force of rotation may cause a damaged wheel to fly apart, and could injure operators or bystanders.

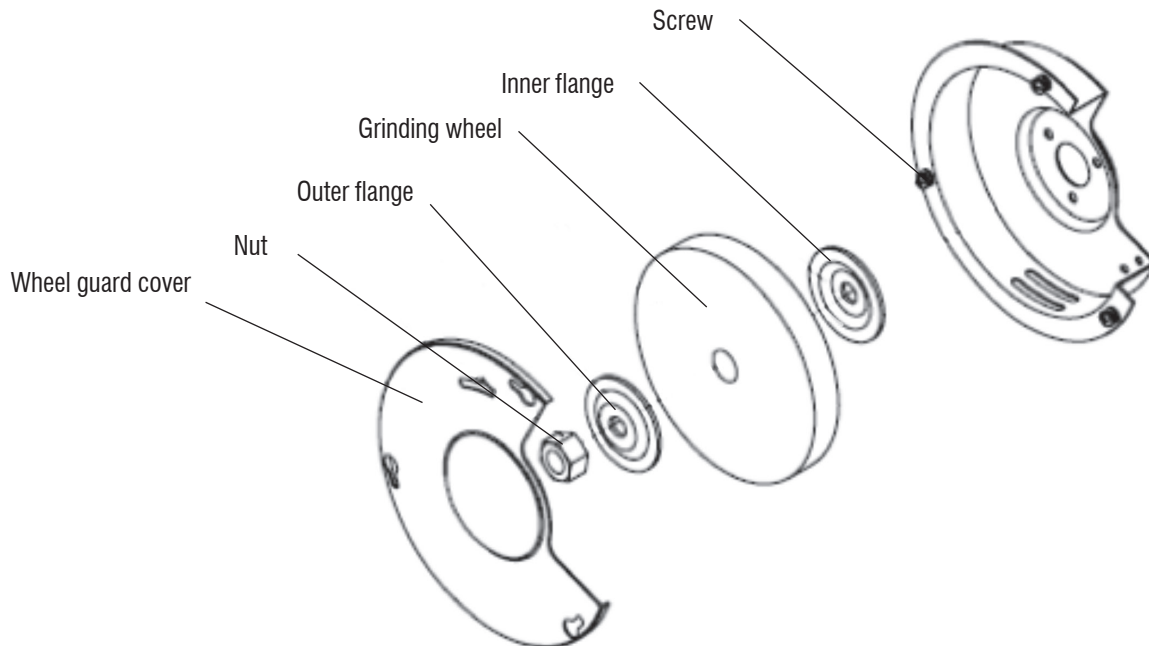



## TOOL REST ADJUSTMENTS AND INSTALLATION

---

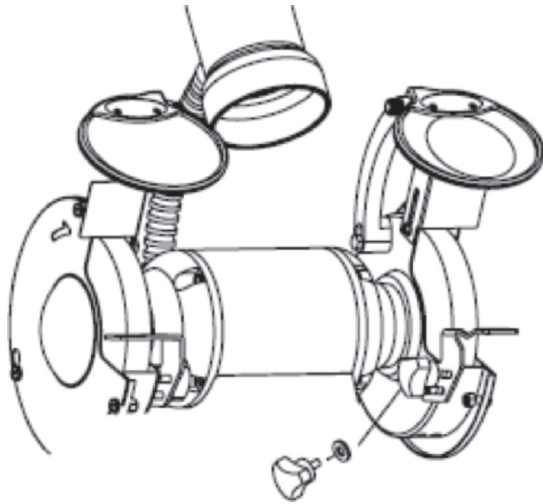

Mount the tool rests to the work rest bracket using the knob and washers.

Before tightening the knob, adjust the gap between the grinding wheel and the work rest to a maximum of 1/8" (3.2 mm). Tighten securely.

### Adjustments

To prevent the workpiece from being pulled and caught between the tool rest and the wheel, readjust the tool rest position whenever necessary to maintain the 1/8" (3.2 mm) distance.

1. Loosen, but do not remove, the knob holding the tool rest arm.
2. Slide the tool rest in or out to achieve a 1/8" (3.2 mm) distance from the grinding wheel surface.
3. Re-tighten the lock knob.

## USING YOUR BENCH GRINDER

---

This 6" Bench Grinder is ideal for use in sharpening chisels, axes and other wood-cutting tools. It is also useful for repairing tips on screwdrivers and drill bits or for removing excess metal burrs from pieces of cut metal.

With the proper accessories, this tool can be used for cleaning metal surfaces using a wire brush or for buffing and polishing using a cloth wheel.

### ON/OFF

The rocker ON/OFF power switch is located on the front of the grinder.

1. Press the side marked ON to turn the grinder on.
2. Press the side marked OFF to turn the grinder off.

## Grinding

- Adjust the tool rest to accommodate large or unusually shaped workpieces.
- Always keep the workpiece moving across the face of the grinding wheel. Grinding continuously on the same spot on the wheel will cause grooves to be worn into the wheel. The wheel may crack or become damaged more easily, and grinding of other objects will be difficult.
- If the workpiece becomes hot, dip it into the water or oil to cool it.
- Always grind on the face of the wheel (around the diameter), NEVER on the sides. Side pressure on grinding wheels can cause cracking and damage.
- If the face of the grinding wheel is worn unevenly, becomes grooved, or is no longer smooth and flat, the wheel should be reshaped with a dressing tool (not supplied).
- If the diameter of the grinding wheel is no longer round, the wheel should be reshaped with a dressing tool or replaced.
- If the surface of the wheel becomes loaded and dull with workpiece material, the wheel should be cleaned with a dressing tool.
- After reshaping, always readjust the tool rests and spark arrestors.

# MAINTENANCE

---

## Maintenance Required

Maintenance Required	Frequency
1. Check power cord.....	Before each use.
2. Check wheels for cracks .....	Before each use.
3. Check moving parts for alignment and binding issues .....	Before each use.
4. Dress Grinding Wheels .....	As needed.
5. Replace Grinding Wheels (see manual section for specifics) .....	As needed.
6. Clean and vacuum dust from the motor housing and other grinder parts ...	As needed.
7. Replace work-light bulb .....	As needed

**Service beyond recommended maintenance on these tools should only be performed by an authorized, qualified technician.**

## Coolant Tray

When grinding, metal objects become heated quickly. It is important to keep moving the object back and forth across the face of the grinding wheel and to cool the object frequently using the coolant tray.

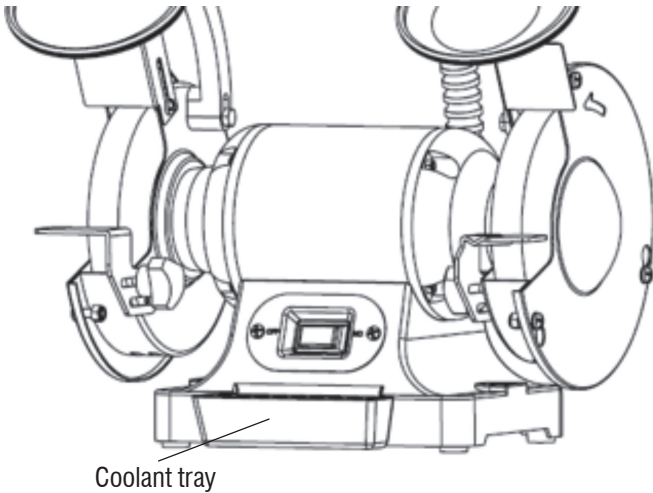

## Work-Light Bulb Replacement

Uses Max 40 W anti-vibration light bulb

# TROUBLESHOOTING

Service on these tools should only be performed by an authorized, qualified technician.

SYMPTOM	PROBABLE CAUSE	CORRECTIVE ACTION
Motor will not start.	<ol style="list-style-type: none"> <li>1. Low Voltage.</li> <li>2. Open circuit in motor or loose connections.</li> <li>3. Blown fuse or breaker.</li> </ol>	<ol style="list-style-type: none"> <li>1. Check power source for proper voltage.</li> <li>2. Inspect all lead connection on motor for loose or open connections. <b>(Send for Servicing)</b></li> <li>3. Short circuit. <b>(Send for Servicing)</b></li> <li>4. Improper match between tool and circuit, fuse or breaker.</li> </ol>
Motor will not start – fuses or circuit breakers tripping or blowing.	<ol style="list-style-type: none"> <li>1. Short circuit in line, cord or plug.</li> <li>2. Short circuit in motor or loose connections.</li> <li>3. Incorrect fuses or circuit breakers in power line.</li> </ol>	<ol style="list-style-type: none"> <li>1. Inspect cord or plug for damaged insulation and shorted wires.</li> <li>2. Inspect all connections on motor for loose or shorted terminals and/or worn insulation.</li> <li>3. Install correct fuses or circuit breakers or switch tool to an appropriately sized circuit.</li> </ol>
Motor overheats.	<ol style="list-style-type: none"> <li>1. Motor overloaded.</li> <li>2. Extension cord too long and of insufficient gauge (weight).</li> </ol>	<ol style="list-style-type: none"> <li>1. Reduce load on motor.</li> <li>2. Utilize an extension cord of appropriate gauge and length or plug tool directly into outlet.</li> </ol>
Motor stalls (resulting in blown fuses or tripped circuit).	<ol style="list-style-type: none"> <li>1. Short circuit in motor or loose connections.</li> <li>2. Low voltage.</li> <li>3. Incorrect fuses or circuit breakers in power line.</li> <li>4. Motor overload.</li> </ol>	<ol style="list-style-type: none"> <li>1. Inspect connections on motor for loose or shorted terminals or worn insulation. <b>(Send for Servicing)</b></li> <li>2. Correct low voltage conditions (for example: improper extension cord length and/or gauge).</li> <li>3. Install correct fuses or circuit breakers or plug tool into an appropriate circuit, matched to an appropriate fuse or breaker.</li> <li>4. Reduce the load on the motor.</li> </ol>
Machine slows when operating.	<ol style="list-style-type: none"> <li>1. Feed rate too great.</li> </ol>	<ol style="list-style-type: none"> <li>1. Reduce the rate at which the workpiece is fed into the working area of the tool (grinding wheel).</li> </ol>
Wavy condition on surface of workpiece.	<ol style="list-style-type: none"> <li>1. Machine vibrating.</li> <li>2. Workpiece not being held firmly.</li> <li>3. Wheel face uneven.</li> <li>4. Wheel is too hard.</li> </ol>	<ol style="list-style-type: none"> <li>1. Ensure machine is securely mounted on a solid surface.</li> <li>2. Use a holding device to firmly retain the workpiece.</li> <li>3. Dress the grinding wheel.</li> <li>4. Use softer wheel, or reduce the feed rate.</li> </ol>
Lines on surface of workpiece.	<ol style="list-style-type: none"> <li>1. Impurity on surface of wheel.</li> <li>2. Workpiece not being held tightly.</li> </ol>	<ol style="list-style-type: none"> <li>1. Dress the grinding wheel.</li> <li>2. Use a holding device to more firmly retain the workpiece.</li> </ol>

## TROUBLESHOOTING

---

SYMPTOM	PROBABLE CAUSE	CORRECTIVE ACTION
Burning spots or cracks in the workpiece.	<ol style="list-style-type: none"> <li>1. Improper type of grinding wheel.</li> <li>2. Improper feed rate.</li> <li>3. Coolant required.</li> </ol>	<ol style="list-style-type: none"> <li>1. Try wheels with softer bond or coarser grit.</li> <li>2. Slow down the rate at which the workpiece is fed into the wheel.</li> <li>3. Introduce coolant.</li> </ol>
Wheel dulls quickly, grit falls off.	<ol style="list-style-type: none"> <li>1. Feed rate is too aggressive.</li> <li>2. Wheel is soft.</li> <li>3. Wheel diameter too small.</li> <li>4. Bad wheel dressing.</li> <li>5. Defective wheel bonding.</li> </ol>	<ol style="list-style-type: none"> <li>1. Decrease feed rate of workpiece into grinding wheel.</li> <li>2. Select a grinding wheel with a harder bond of material.</li> <li>3. Replace wheel.</li> <li>4. Dress the wheel.</li> <li>5. DO NOT USE – return wheel to point of purchase.</li> </ol>
Wheel clogs and workpiece shows burn marks.	<ol style="list-style-type: none"> <li>1. Wheel is too hard.</li> <li>2. Feed rate is too slow.</li> <li>3. Bad wheel dressing.</li> <li>4. Coolant required.</li> </ol>	<ol style="list-style-type: none"> <li>1. Select a grinding wheel with a softer bond of material.</li> <li>2. Increase the feed rate of the workpiece into the grinding wheel.</li> <li>3. Dress the wheel.</li> <li>4. Introduce coolant.</li> </ol>

# PARTS SCHEMATIC

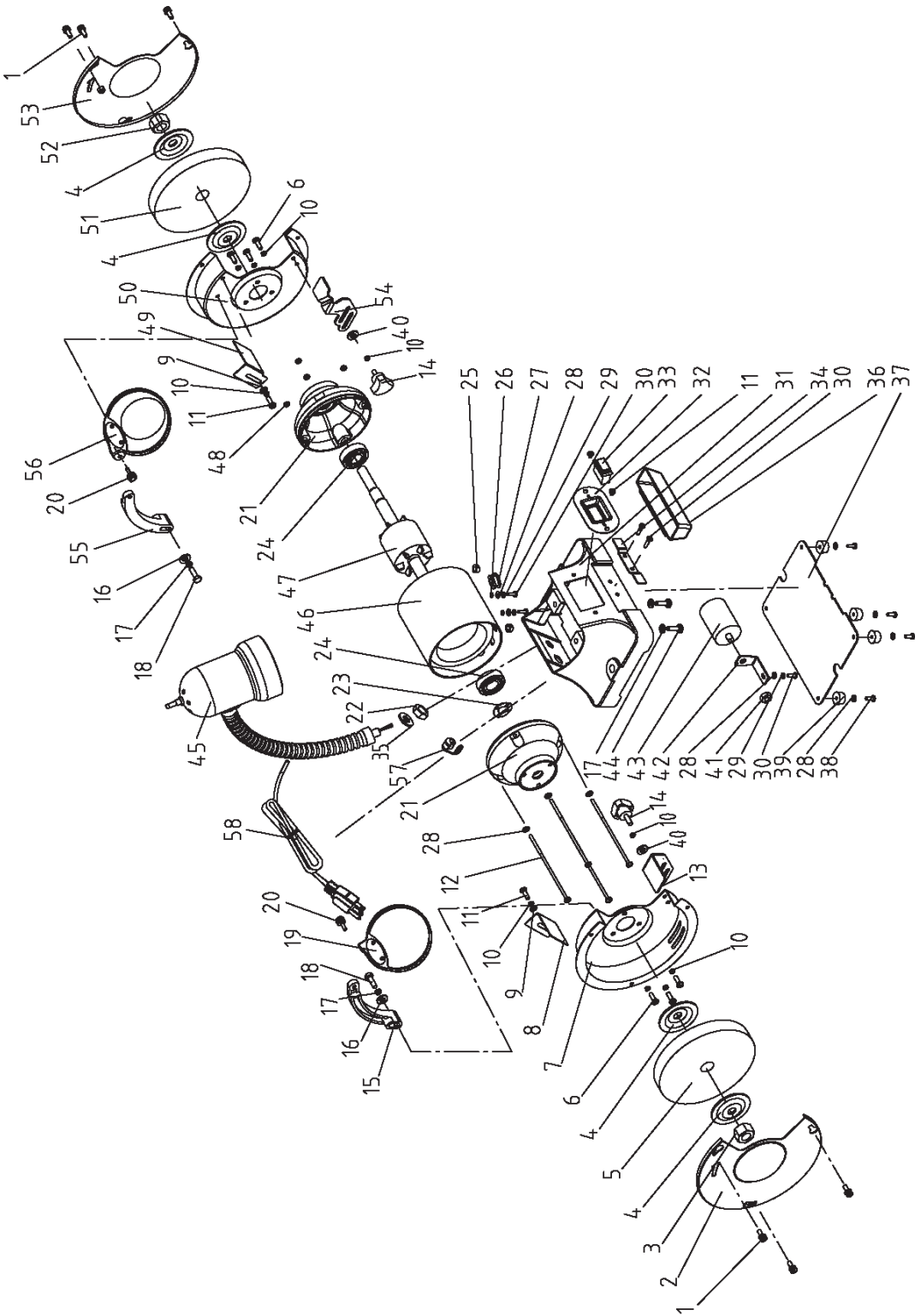

## PARTS LIST

Key Number	Description	Qty.
1	Star-head Screw Assembly	6
2	Left Safety Guard Cover	1
3	Hex Nut	1
4	Flange	4
5	Wheel (8 x 3/4 x 1/2")	1
6	Star-head Screw	6
7	Left Safety Guard Plate Assembly	1
8	Left Spark Shield	1
9	Flat Washer	2
10	Lock Washer	8
11	Star-head Screw	4
12	Star-head Screw	4
13	Left Work Rest	1
14	Locking Knob	2
15	Left Eye Shield Mounting Rod	1
16	Flat Washer	2
17	Lock Washer	4
18	Star-head Screw	2
19	Left Eye Shield Assembly	1
20	Eye Shield Locking Knob	2
21	End Cap	2
22	Lamp Lock nut	1
23	Spring Wave Washer	1
24	Bearing	2
25	Special Nut	2
26	Toothed Lock Washer	3
27	Cord Bushing	1
28	Flat Washer	6
29	Lock Washer	6

Key Number	Description	Qty.
30	Star-head Screw	1
31	Base	1
32	Switch Plate	1
33	Single Switch	1
34	Coolant tray clip	1
35	Star-head Screw	2
36	Coolant tray	1
37	Plate	1
38	Star-head Screw	4
39	Rubber Foot	4
40	Star-head Screw	2
41	Hex Nut	1
42	Capacitor support	1
43	Capacitor 8 $\mu$ F300 V	1
44	Star-head Screw	2
45	Lamp Assembly	1
46	Stator	1
47	Rotor	1
48	Hex Nut	4
49	Right Spark Shield	1
50	Right Safety guard plate Assembly	1
51	Wheel (8 x 3/4 x 1/2")	1
52	Hex Nut (White)	1
53	Right Safety Guard Cover	1
54	Right Work Rest	1
55	Right Eye Shield Mounting Rod	1
56	Eye Shield with Magnifier	1
57	Cord Clip	4
58	Cord & Plug	1

## WARRANTY POLICY

---

### **ITC Tools and Equipment**

All ITC branded products are guaranteed against defects in workmanship and materials, when the product is used for the purpose for which it was designed, for the useful life of the tool. Any ITC product that fails during normal use and within the specified warranty period for that product will be repaired or replaced at ITC's discretion.

ITC product warranties apply to ITC products purchased new from an authorized ITC distributor to the original retail purchaser only.

See specific product warranty statements below for more information and limitations. This warranty is void if there is evidence of misuse, abuse, alterations, or normal wear and tear. Normal wear and tear of moving parts can be repaired by purchasing the appropriate ITC replacement part.

No claim for indirect, incidental, or consequential damages of any type will be considered including loss time or wages, or loss of production. All products are sold with this specific understanding.

Product for which there is a warranty claim must be returned, freight prepaid to an authorized ITC distributor, or in the case of power tools, machinery and hydraulic equipment, to an authorized ITC OR JET warranty repair centre. All returns must include proof of purchase and an explanation of the defect or failure. Go to [www.surewerx.com](http://www.surewerx.com) for a list of authorized warranty repair centres.

Except as listed below, all ITC brand tools are covered by our Limited Lifetime Warranty.

### **ITC Brand 1 Year Limited Warranty**

Hydraulic Jacks, Pallet Trucks, Bench Grinders, Machinery, Cable Pullers, Service cart, Automotive Type Air Tools, Creepers, Air and Water Hose Reels, Multimeter and Thermometer (batteries excluded), Torque Wrenches (calibration is not covered by warranty except when required due to warranty repair service)