

Prod. No. 222332  
Mod. No. JHVG-712

# OPERATOR'S MANUAL

## 7" x 12" 1 HP 3 Speed Gearbox Bandsaw

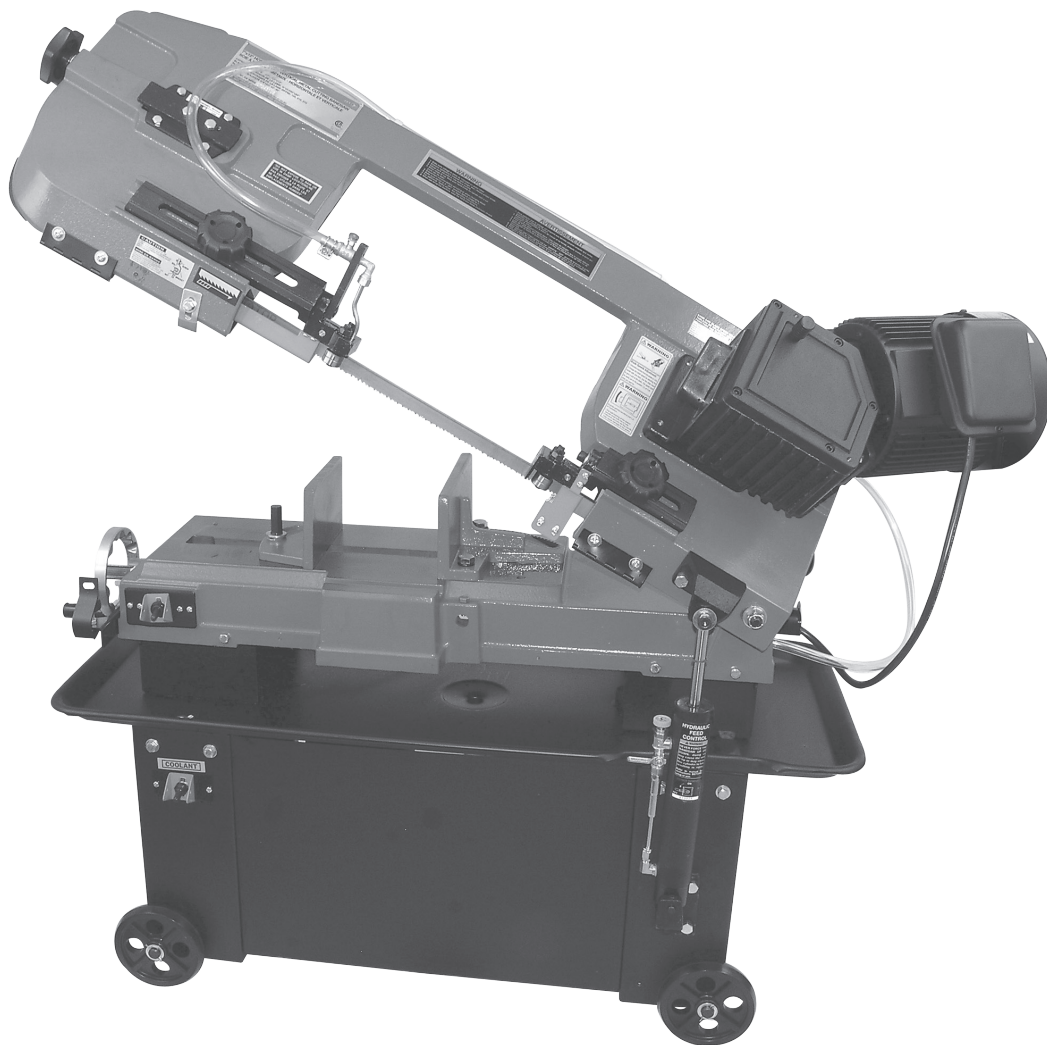

**⚠ WARNING**

- **Completely read and understand this instruction manual before attempting assembly or operation.**
- **The bandsaw is designed and intended for use by whom properly trained and experienced only. If you aren't familiar with the proper and safe operation of a bandsaw, don't use until proper training and knowledge have been obtained.**

- Make certain the machine is properly grounded.
- Before operating the machine, remove tie, rings, watches, other jewelry, and roll up sleeves above the elbows. Remove all loose clothing and confine long hair. Do not wear gloves.
- Keep the floor around the machine clean and free of scrap material, oil and grease.
- Keep machine guards in place at all times when the machine is in use. If removed for maintenance purposes, use extreme caution and replace the guards immediately.
- Do **not** over reach. Maintain a balanced stance at all times so that you do not fall or lean against blades or other moving parts.
- Make sure all machine adjustments or maintenance with the machine unplugged from the power source.
- Use the right tool. Don't force a tool or attachment to do a job which it was not designed for.
- Replace warning labels if they become obscured or removed.
- Make certain the motor switch is in the **off** position before connecting the machine to the power supply.

- Must give your work undivided attention. Looking around, carrying on a chat, and such as "horse-play" are careless acts that can result in serious injury.
- Keep visitors a safe distance from the work area.
- Use recommended accessories; improper accessories may be hazardous.
- Make a habit of checking to see that keys and adjusting wrenches are removed before turning on the machine.
- Always keep hands and fingers away from the blade when the machine is running.
- Never hold the material with the saw in the horizontal position. Always use the vise and clamp it securely.
- Read and understand warnings posted on the machine.
- Always provide adequate support for long and heavy material.
- Use a sharp blade and keep machine clean for best and safest performance.
- Failure to comply with all of these warnings may cause serious injury.

**TOGGLE SWITCH**

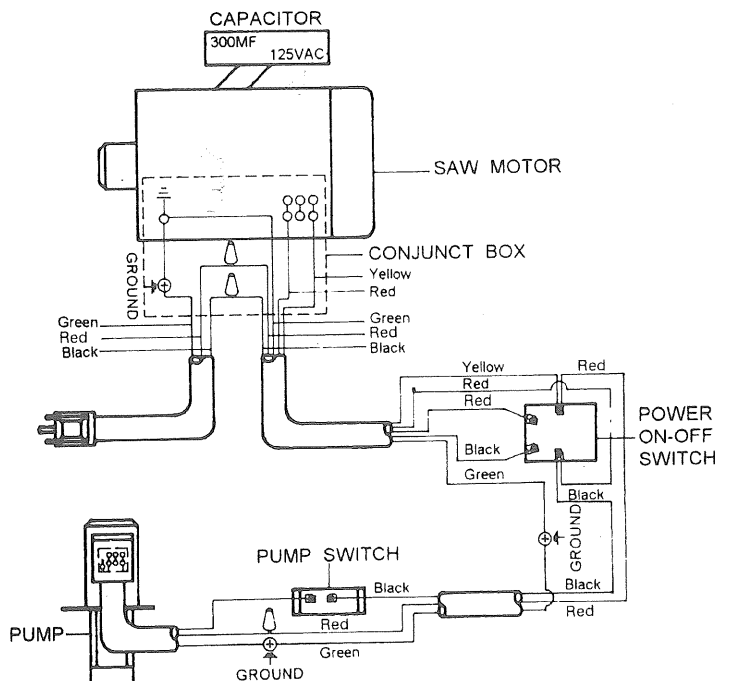

## Specifications

### Capacity:

Round.....	7"
Rectangle.....	7"X12"
Throat Depth.....	7"
Vertical Worktable.....	9-1/4"X20"
Vise Tilts.....	45°
Blade Speed.....50Hz	39,66,82 MPM
.....60Hz	125,215,270 SFPM
Motor.....	1HP,115/230V
.....	Prewired 115V
Floor Space Required....	49-1/2"X17-1/32"
Net Weight(approx.).....	318Lbs.
Shipping Weight.....	345Lbs.

## Shipping Container Contents

- 1 Saw
- 2 Wheel Axle
- 4 Wheel
- 4 Split Pin
- 1 Material Stop Bar
- 1 Material Stop
- 1 Vertical Cutting Plate

## Tools Required for Assembly

- #2 Cross Point Screwdriver
- Pliers

## Unpacking and Clean-Up

1. Finish uncrating the saw. Inspect it for shipping damage. If any damage has occurred, contact your distributor.
2. Unbolt the saw from the skid and place it on a level surface.
3. Clean rust protected surfaces with kerosene, diesel oil, or a mild solvent. Do not use cellulose based solvents such as paint thinner or lacquer thinner. These will damage painted surfaces.

## ⚠ WARNING

Disconnect bandsaw from the power source before making any repairs or adjustments!

Failure to comply may cause serious injury!

## Assembly

1. Place blocking under the ends of the saw base to allow wheel installation. **Caution:** Make sure saw is steady while temporarily supported.
2. Slide wheel axles through holes in base.
3. Slide wheels onto axles and fasten with pins. Bend pins to hold in place.
4. Slide material stop bar (A, Fig. 1) into base and secure by tightening bolt (B). Slide material stop (C) onto bar and tighten bolt (D).
5. Remove transportation strap and keep for later use should the saw be moved any distance.

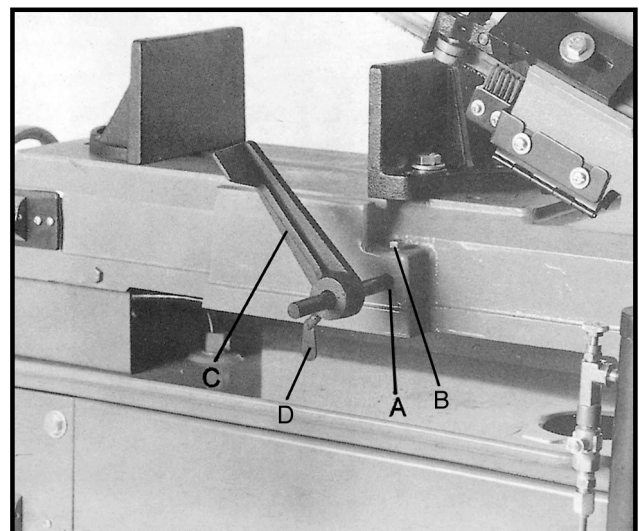

Fig. 1

## Coolant Tank Preparation

Use of a water-soluble coolant will increase cutting efficiency and prolong blade life. Do not use black cutting oil as a substitute. Follow manufacturers instructions as to its uses and precautions.

1. Disconnect machine from the power source.
2. Remove coolant return hose from tank cover.
3. Slide the tank out of the saw base and the cover containing the coolant.
4. Fill tank to approximately 80% of capacity.
5. Replace the cover onto the tank and place the tank assembly back into the base.
6. Place the return hose back into the hole at the tank cover.

## Electrical Connections

**⚠ WARNING**

**All electrical connections must be done by a qualified electrician!**

**Disconnect the bandsaw from the power source before changing any voltage components!**

**Failure to comply may cause serious injury!**

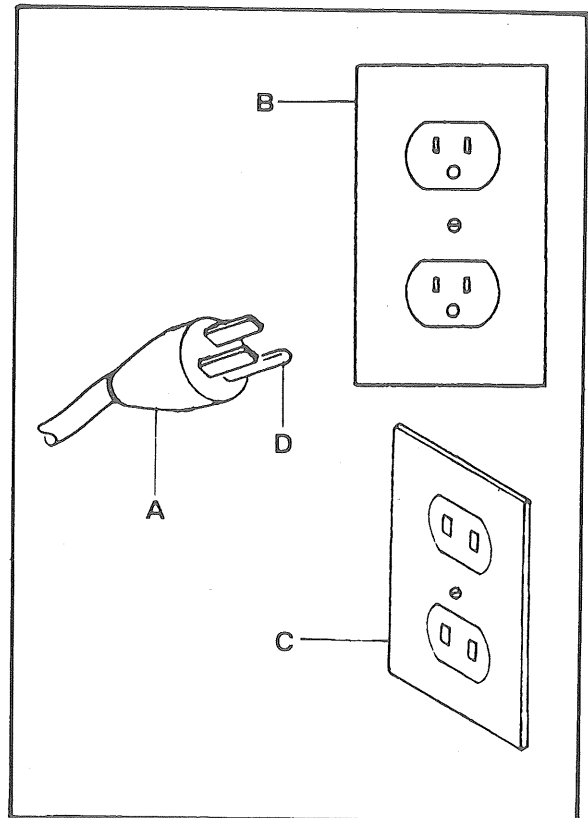

**Fig. 2**

The 712G bandsaw is rated 115/230v and before leaving the factory prewired at 115V. To switch to 230V operation, follow the wiring diagram found on the inside of the motor junction box. The plug end will have to be replaced with a plug that is rated at 230V. The coolant pump wiring must be changed also. Follow the diagram found on the cooling pump head to switch to 230V operation.

This bandsaw is equipped with a three prong plug (A) in Fig. 2 against shock hazards and should be plugged into a grounded three prong receptacle (B). Where a two prong receptacle (C) is encountered, it must be replaced with one as (B). This job should be done by a qualified electrician. Do not cut off the round grounding prong (D).

Before hooking up to the power source, be sure the power and coolant switches are in the off position.

## Hydraulic Feed Selector Operation

The hydraulic feed selector is used to control the blade feed rate and to lock the arm in the vertical position. To increase the feed rate, turn knob (A, Fig. 3) counter-clockwise. To decrease the feed rate, turn knob (A) clockwise. To turn off the flow of hydraulic fluid, remain the lever (B) the same position as in figure 3. To turn the hydraulic cylinder on, raise the lever (B) to the 12 o'clock position.

## Prior to Operation

1. Check to see blade tooth direction matches diagram on saw body.
2. Check to see that blade is properly seated on wheels after proper tension has been applied.
3. Set blade guide roller bearings snug against blade. See "Adjusting Blade Guide Bearings" for more detail.
4. Check for slight clearance between back up rollers and the back edge of blade.
5. Position both blade guides as close to work as possible.
6. Select proper speed and feed rate for material being cut.
7. Work to be cut must be held securely in vise.
8. Check to see that coolant level is adequate.
9. Do not start cut on a sharp edge File it off first.
10. Keep machine lubricated. See "Lubrication" section.

## Adjusting Blade Guides

1. **Disconnect machine from the power source.**
2. Loosen knob (A, Fig. 4) and Knob (B). Slide blade guide assemblies as close as possible to the material without interfering with the cut.
3. Tighten knob (A) and knob (B) and connect machine to the power source.

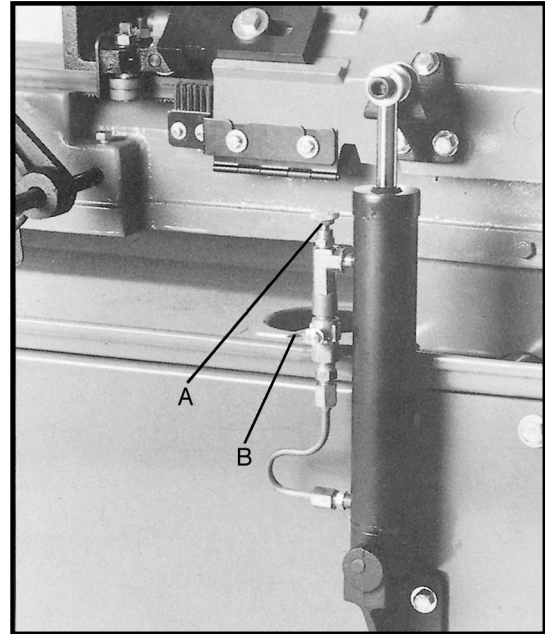

Fig. 3

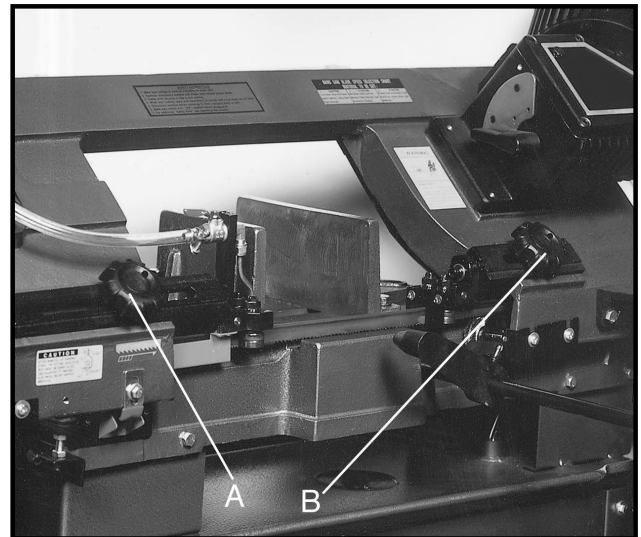

Fig. 4

## Vise Adjustment

 **WARNING**

Do not make any adjustments or load/unload material from vise while machine is running!

Failure to comply may cause serious injury!

To set the vise for 0 to 45 degree cutting:

1. Remove bolt assemblies (C, Fig. 5).
2. Position vise and re-install as pictured in Fig. 10. Pay particular attention to bolt hole location.
3. Set vise to desired angle, re-install bolts, and tighten nut and bolt assemblies.
4. Adjust movable vise parallel to fixed vise by loosening bolt (A, Fig. 6 ), adjusting to parallel, and tightening bolt.

To set vise for maximum width of material cutting:

1. Remove nut and bolt assemblies.
2. Position vise and re-install bolt assemblies as pictured in Fig 5.

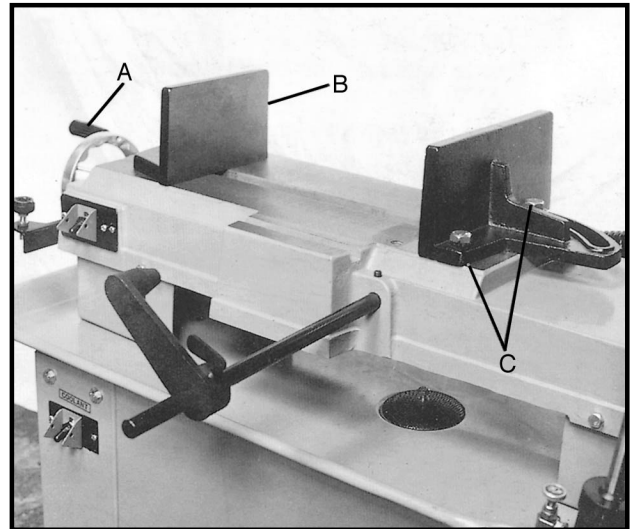

Fig. 5

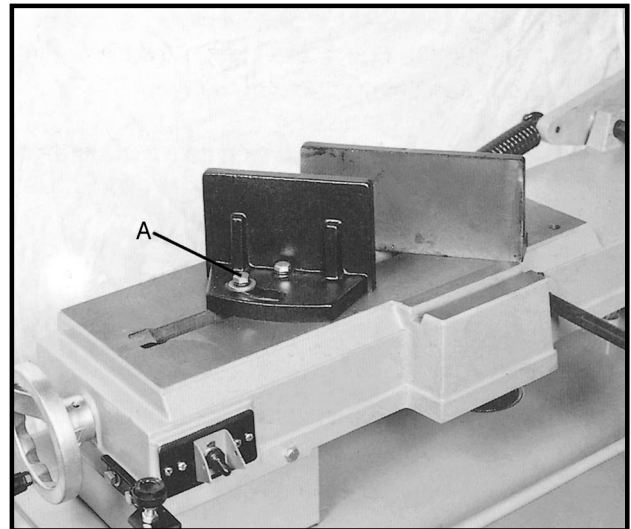

Fig. 6

## Adjusting Blade Square to Vise

1. Disconnect machine from the power source.
2. Place a machinist's square as pictured in figure 7. Square should lie along entire length of vise and blade without a gap.
3. If adjustment is necessary, loosen bolts holding vice and adjust vise so that square lines up properly. Tighten bolts.
4. Connect machine to the power source.



Fig. 7

## Adjusting Blade Tension

**⚠ WARNING**

**Disconnect machine from the power source!**

**Blades are sharp! Use extra care when removing, installing or adjusting!**

**Failure to comply may cause serious injury!**

Blade tension is important to the proper operation of the saw. Proper blade tension is 22,000 to 25,000 lbs. per square inch as measured on a blade tension gauge.

To set the blade tension without the use of a blade tension gauge:

1. Install blade between wheel and insert blade between bearings on blade guides.
2. Tension blade slightly to remove any sag in blade between blade wheels.
3. Turn blade tension knob (A, Fig. 8 ) one and three quarter to two revolutions clockwise. This equals approximately 23,000 lbs. of blade tension.

**CAUTION!**

**Do not over tighten blade. This may cause blade to stretch and warp.**

4. After blade has been completely installed, close covers, connect to the power source, and run saw for two to three minutes so blade can seat properly.
5. Disconnect machine from the power source. Open cover and loosen blade just until it begins to sag.
6. Tighten blade until it becomes straight between blade wheel and all sag has been eliminated.
7. Tighten blade by turning blade tension wheel two full revolutions. Blade is now properly tensioned and ready for use.
8. Close covers and connect machine to the power source.

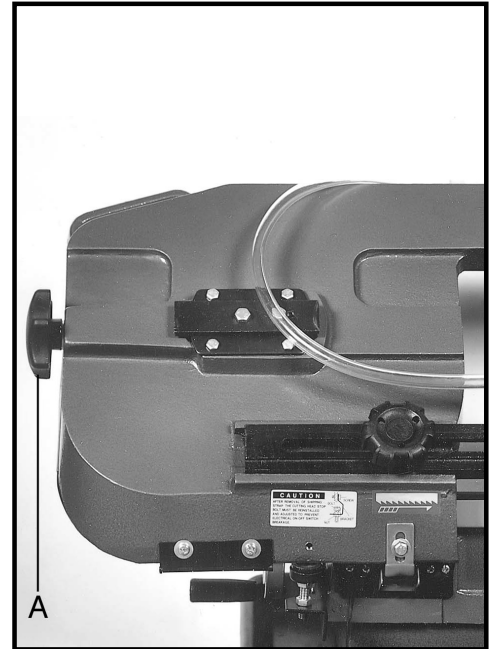

**Fig. 8**

## Changing Blades

 **WARNING**

**Never operate this saw unless all blade guards are installed and in proper working order!**

**Never adjust blade brush while machine is running!**

**Failure to comply may cause serious injury!**

**CAUTION!**

**This machine is designed and intended for use with blades that are 3/4" wide by .032" thick by 93" long. Use of blades with different specifications may cause inferior performance.**

1. Disconnect machine from the power source.
2. Raise saw arm to vertical position and lock in place by turning hydraulic cylinder off.
3. Remove red blade guard assembly (A, Fig. 9 ) by removing two screws (B).

 **WARNING**

**It is essential this guard be installed after the new blade has been fitted!**

**Failure to comply may cause serious injury!**

4. Remove brush assembly (C) by removing a screw (D).
5. Loosen blade tension by turning blade tension knob counter-clockwise.
6. Carefully remove old blade. **Caution: blade teeth are sharp. Handle with care.**
7. Install new blade by placing blade between blade guides first. Make sure blade teeth face the same direction as indicated on the label found on the saw arm.
8. Place blade around both wheels. Make sure the blade edge rests near the wheel flange on both wheels.

9. Turn blade tension knob clockwise to tension blade. Do not over tension. See section titled "Adjusting Blade Tension".
10. Close blade cover door and secure with lock knobs.
11. Attach red blade guard and brush assembly.
12. Connect machine to the power source.
13. Run saw and make sure blade is tracking properly.

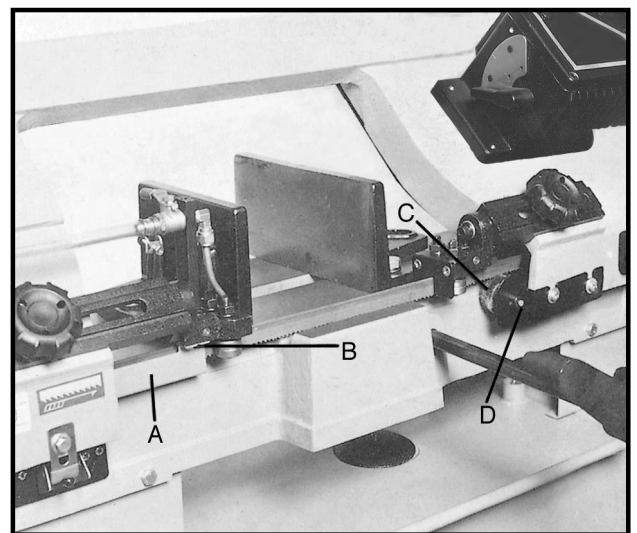

**Fig. 9**



## Changing Blade Speed

To set speed for 1 to 3 position.

1. Disconnect machine from the power source.
2. Turn the handle (A, Fig 10) with one hand, and use the other hand to give a pull at the blade. The blade speed can be freely set at the position marked 1, 2, or 3.(B).
3. While being set at the position 1, speed comes to 125 FPM which is for the cut of Tool steel, Stainless steel, Hard cast iron, Alloy steel, and Hard Bronze.
4. Position 2, speed comes to 215 FPM for the cut of mild steel, soft cast iron, medium hard Bronze, hard Aluminum, and Plastics.
5. Position 3, speed to 270 FPM for Plastics, soft, or medium soft Alum, Wood, and other light materials.

6. Connect machine to the power source.

Note: There is the speed selection chart posted on the above of the gear box.

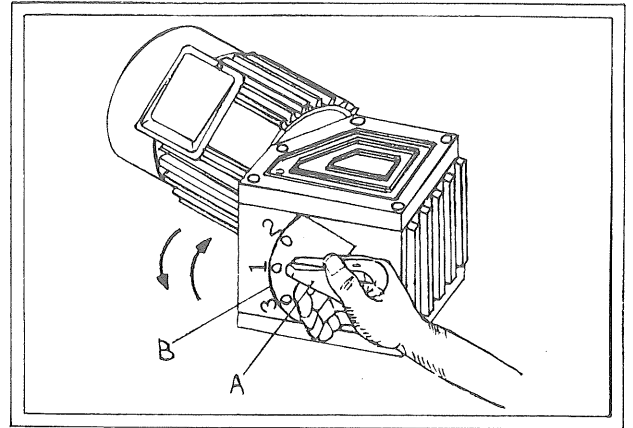
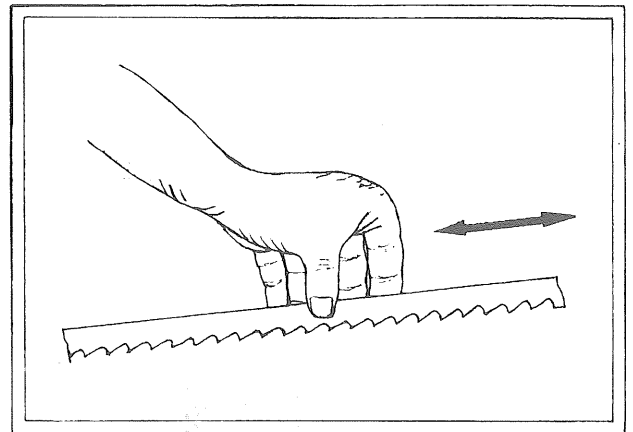

Fig. 10



## Adjusting Blade Square to Table

1. Disconnect machine from the power source.
2. Place machinist's square on table next to blade as pictured in Fig. 11 .
3. Check to see blade makes contact with square along the entire width of the blade.
4. If adjustment is necessary, loosen bolts (A, Fig. 11 ) and rotate blade guide assemblies slightly in the same direction until blade makes contact with the square along it's entire width.
5. Tighten bolts (A).
6. Connect machine to the power source.

Note: If adjustment to square blade to table is necessary, be sure to check blade adjustments again.

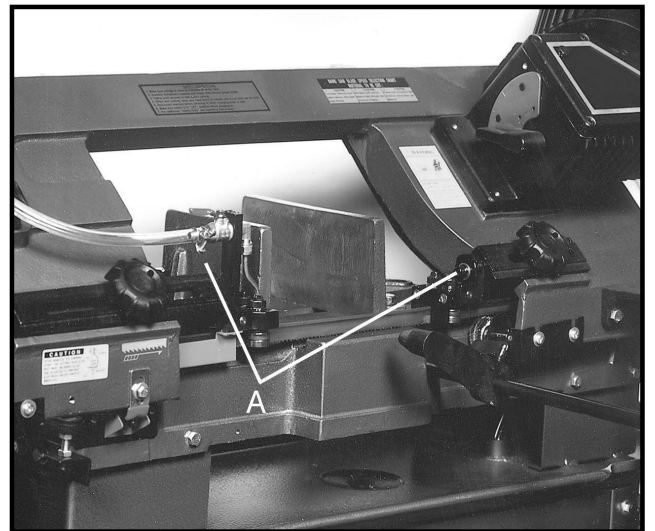

Fig. 11

## Adjusting Blade Tracking

 **WARNING**

**Blade tracking adjustment requires running the saw with the back cover open. This adjustment must be completed by qualified persons only!**

**Failure to comply may cause serious injury!**

**Note:** Before making any tracking adjustments, try a new blade. Warped blades will not track.

Blade tracking has been set at the factory and should not require adjustment. If a tracking problem occurs, adjust the machine as follows:

1. Move saw arm to the vertical position and lock in place by turning off the hydraulic cylinder valve.
2. Confirm that blade tension is set properly. To adjust, see section titled "Adjusting Blade Tension".
3. Open back cover by loosening lock screws.
4. Run saw and observe blade. Blade should run next to but not tightly against wheel flange.
5. Loosen bolts (A, Fig. 12).
6. Turn set screw (B) while observing blade tracking on wheel. Turn set screw clockwise to track blade closer to the wheel flange. Turn set screw counter-clockwise to track blade away from the wheel flange.
7. Once tracking is set, tighten bolts (A).

## Adjusting Bow Weight

Bow weight is a very important adjustment to the saw. If the bow weight is not set properly, one can expect poor performance, crooked cuts, tooth stripping, stalling, and the blade popping off the blade wheels. The hydraulic feed rate unit will not compensate for improper bow weight and should not need adjustment. If adjustment is necessary:

1. **Disconnect machine from the power source.**
2. Turn hydraulic cylinder valve on and place saw arm in horizontal position.

3. Turn feed rate valve on hydraulic cylinder counter-clockwise until it stops.
4. Place a fish-type scale under blade tension handle and lift the saw arm. Scale should indicate approximately 12-15 lbs.
5. Adjust tension to approximately 12-15 lbs. by turning bolt(A- Fig.13)
6. Connect machine to the power source.

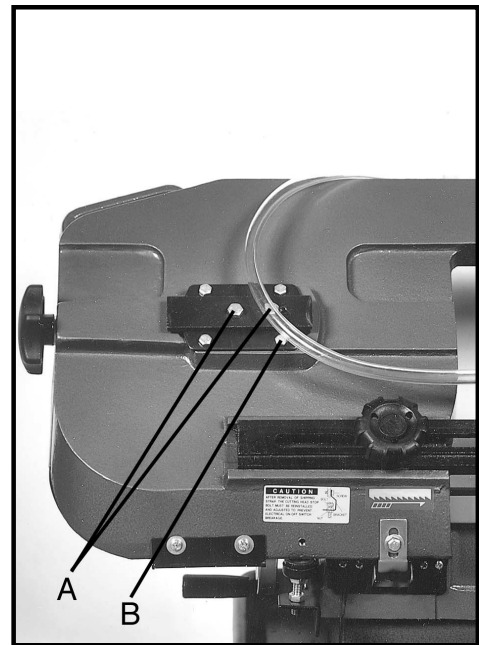

**Fig. 12**

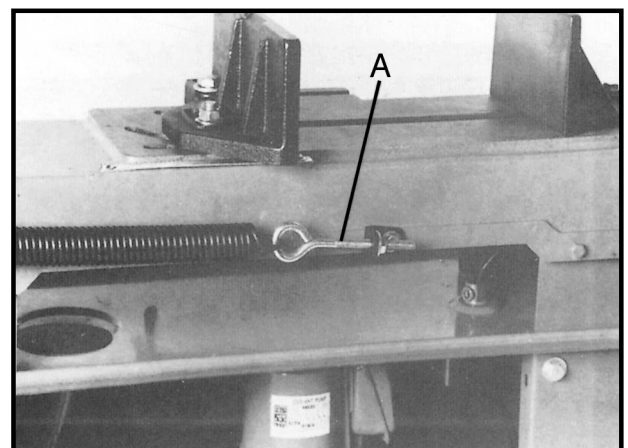

**Fig. 13**

## Adjusting Blade Guide Bearings

### CAUTION!

This machine is designed and intended for use with blades that are 3/4" wide by .032" thick by 93" long. Use of blades with different specifications may cause inferior performance.

1. Disconnect machine from the power source.
2. Raise arm to vertical position and lock in place by turning off the hydraulic cylinder valve.
3. Loosen hex cap screw (A, Fig.14 ) and adjust assembly so that back roller bearing is approximately .003" - .005" from the back of the blade.
4. Turn nut (B) to adjust eccentric bearing snug to the blade. Blade should still move up and down freely when grasped as in Fig. 15 .  
**Warning! Make sure power is disconnected and hands are protected before handling blade.** Be sure that blade teeth do not interfere with the roller bearings.
5. Repeat for other blade guide assembly.
6. Connect machine to the power source.

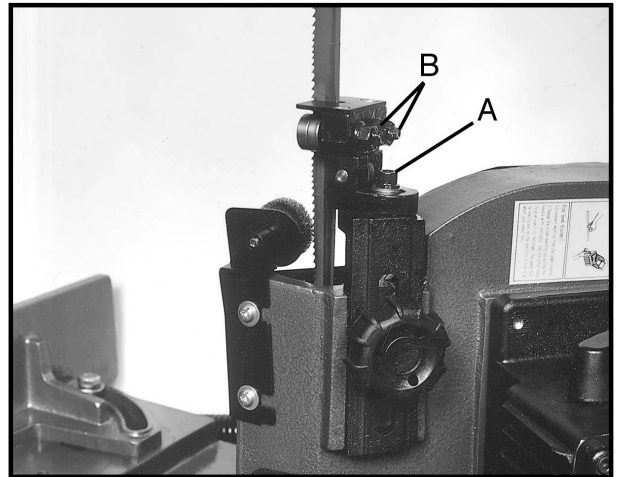

Fig. 14

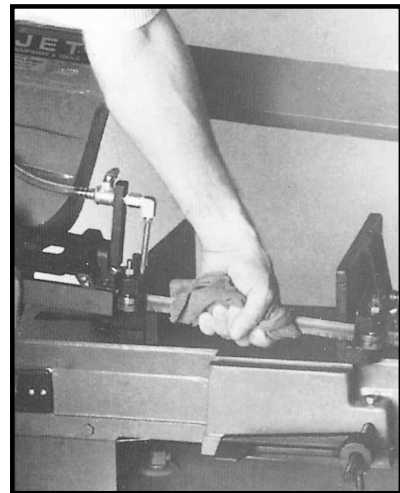

Fig. 15

## Adjusting Automatic Shutoff

The saw should stop after the cut has been completed:

1. If the saw completes the cut and continues to run, adjust the stop tip (A, Fig.16 ) down.
2. If the saw shuts off before the cut is complete, adjust the stop tip (A) up.
3. If the saw stops cutting but continues to run, adjust the stop bolt (B).

The saw is properly adjusted when the saw shuts off just after the blade has finished the cut.

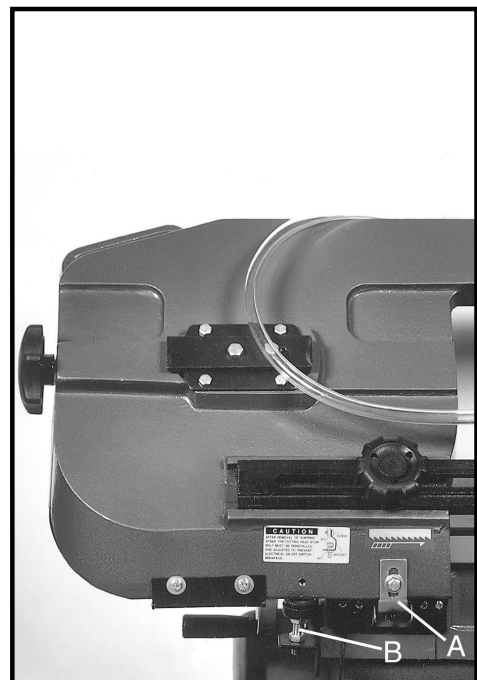

Fig. 16

## Vertical Cutting Plate Assembly

**Note:** These steps are only necessary if using the bandsaw for vertical cutting.

**⚠ WARNING**

**Disconnect bandsaw from the power source before making any repairs or adjustments!**

**Failure to comply may cause serious injury!**

1. Disconnect the bandsaw from the power source.
2. Raise the arm to the vertical position by turning the hydraulic cylinder valve to the off position.
3. Remove two screws (A, Fig. 17) and remove the deflector plate (B, Fig. 17)
4. Guide the blade through the slot in the table and fasten with two screws. See Fig. 18.
5. To lower the arm, turn the hydraulic cylinder arm to any of the on positions.

### Lubrication

Ball bearings on the blade guide assemblies and the blade wheels are permanently sealed and require no lubrication.

Lightly lubricate vise screw with #2 tube grease.

Change gear box oil after the first 90 days of operation. There after, change every six months.

To change gear box oil:

1. Disconnect machine from the power source.
2. Raise the saw arm to vertical position.
3. Release the drain hold (A, Fig. 19) to draw off gear oil by loosening the Hex socket screw (B).
4. Replace the screw (B) after oil completely flows off.
5. Place the saw arm back to horizontal position.
6. Fill Gear box with approximately 0.3 liter of gear oil through the hole of the vent screw. (C).

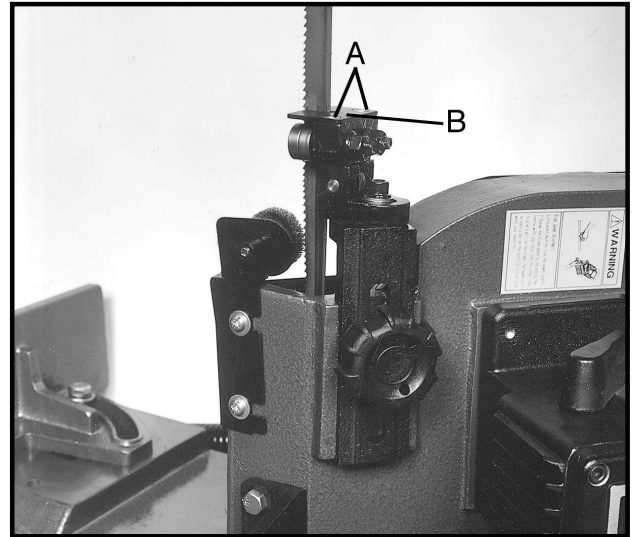

Fig. 17

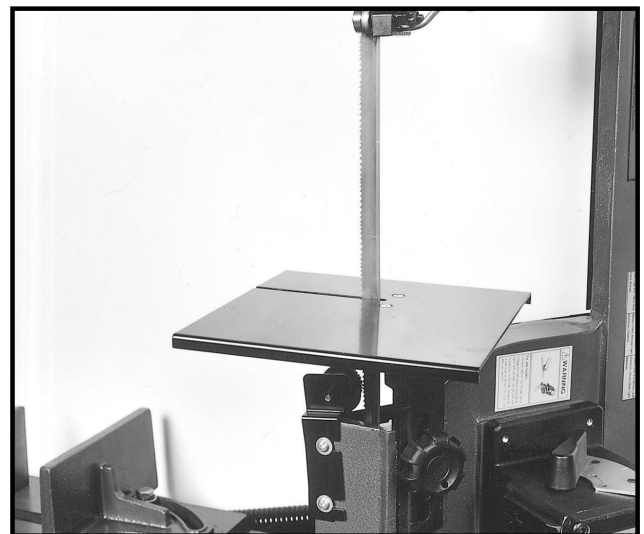

Fig. 18

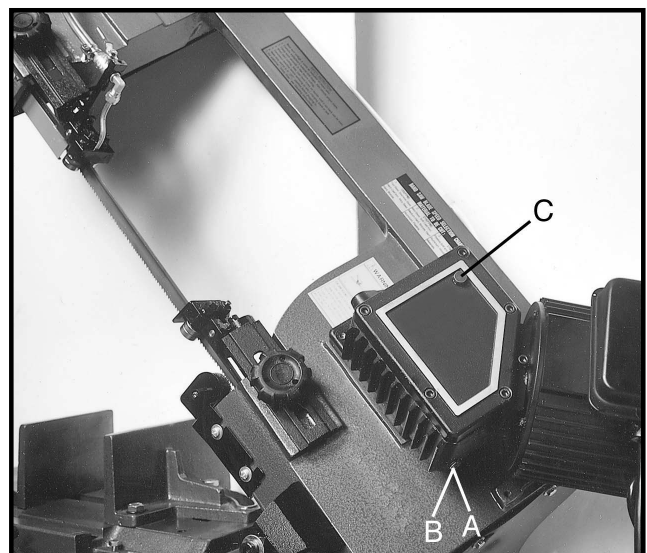

Fig. 19

TROUBLE SHOOTING CHART

SYMPTOM	POSSIBLE CAUSE (s)	CORRECTIVE ACTION
Excessive Blade Breakage	<ol style="list-style-type: none"> <li>1. Incorrect blade tension</li> <li>2. Incorrect speed or feed</li> <li>3. Material loose in vise</li> <li>4. Blade rubs on wheel flange</li> <li>5. Teeth too coarse for material</li> <li>6. Teeth in contact with work before saw is started</li> <li>7. Misaligned guides</li> <li>8. Blade too thick for wheel diameter</li> <li>9. Cracking at weld</li> </ol>	<ol style="list-style-type: none"> <li>1. Adjust to where blade just does not slip on wheel</li> <li>2. Check Machinist Handbook</li> <li>3. Clamp work securely</li> <li>4. Adjust wheel alignment</li> <li>5. Check Machinist Handbook for recommended blade type</li> <li>6. Place blade in contact work after motor is started</li> <li>7. Adjust</li> <li>8. Use thinner blade</li> <li>9. Make longer annealing cycle</li> </ol>
Permature Blade Dulling	<ol style="list-style-type: none"> <li>1. Teeth too corase</li> <li>2. Too much speed</li> <li>3. Inadequate feed pressure</li> <li>4. Hard spots or scale in/on material</li> <li>5. Work hardening of material (especially stainless steel)</li> <li>6. Blade installed backwards</li> <li>7. Insufficient blade tension</li> </ol>	<ol style="list-style-type: none"> <li>1. Use finer tooth blade</li> <li>2. Try next lower speed</li> <li>3. Decrease spring tension on side of saw</li> <li>4. Reduce speed increase feed pressure (Scale) Increase feed pressure (Hard Spots)</li> <li>5. Increase feed pressure by reducing spring tension</li> <li>6. Remove blade twist inside out and reinstall blade</li> <li>7. Increase tension to proper level</li> </ol>
Bad Cuts (Crooked)	<ol style="list-style-type: none"> <li>1. Work not square</li> <li>2. Feed pressure too great</li> <li>3. Guide bearing not adjusted properly</li> <li>4. Inadequate blade tension</li> <li>5. Blade guides spaced out too much</li> <li>6. Dull blade</li> <li>7. Speed incorrect</li> <li>8. Blade guide assembly loose</li> <li>9. Blade guide bearing assembly loose</li> <li>10. Blade tracks too far away from wheel flanges</li> </ol>	<ol style="list-style-type: none"> <li>1. Adjust vise to be square with blade Always clamp work tightly in vise</li> <li>2. Reduce pressure by increasing spring tension on side of saw</li> <li>3. Adjust guide bearing to .001 greater than max thickness. including weld of the saw.</li> <li>4. Inceas ade tension a little at a time.</li> <li>5. Move guide as close to work as possible.</li> <li>6. Replace blade</li> <li>7. Check manual for recommended speeds</li> <li>8. Tighten</li> <li>9. Tighten</li> <li>10. Retrack blade according to operating instructions</li> </ol>
Bade cuts (Rough)	<ol style="list-style-type: none"> <li>1. Too much speed or feed</li> <li>2. Blade is too coarse</li> </ol>	<ol style="list-style-type: none"> <li>1. Reduce speed and feed</li> <li>2. Replace with finer blade</li> </ol>
Blade is twisting	<ol style="list-style-type: none"> <li>1. Cut is binding blade</li> <li>2. Too much blade tension</li> </ol>	<ol style="list-style-type: none"> <li>1. Decrease feed pressure</li> <li>2. Decrease blade tension</li> </ol>
Unusual Wear on Side/Back of Blade	<ol style="list-style-type: none"> <li>1. Blade guides worn</li> <li>2. Blade guide bearings not adjusted properly</li> <li>3. Blade guide bearing bracket is loose</li> </ol>	<ol style="list-style-type: none"> <li>1. Replace</li> <li>2. Adjust as per operators manual</li> <li>3. Tighten</li> </ol>
Feeth Ripping from blade	<ol style="list-style-type: none"> <li>1. Tooth Too coarse for work</li> <li>2. Too heavy feed/ too slow feed</li> <li>3. Vibrating work place</li> <li>4. Gullets loading</li> </ol>	<ol style="list-style-type: none"> <li>1. Use finer tooth blade</li> <li>2. Increase feed pressure and/or speed</li> <li>3. Clamp work Securely</li> <li>4. Use coarse tooth blade or brush to remove chips</li> </ol>
Motor Running too Hot	<ol style="list-style-type: none"> <li>1. Blade tension too high</li> <li>2. Drive belt tension too high</li> <li>3. Blade is too coarse for work (Pipes especially)</li> <li>4. Blade is too fine for work (Heavier, soft materialy)</li> <li>5. Gear not aligned properly</li> <li>6. Gears need lubrication</li> <li>7. Idler wheel needs lubrication</li> </ol>	<ol style="list-style-type: none"> <li>1. Reduce tension on blade</li> <li>2. Reduce tension on drive belt</li> <li>3. Use finer blade</li> <li>4. Use coarser blade</li> <li>5. Adjust gears so that worm is in center of gear</li> <li>6. Check oil bath</li> <li>7. Oil bearing/shaft on idler wheel</li> </ol>

## PART LIST

PART NO.	DESCRIPTION	SIZE NO.	Q'TY	PART NO.	DESCRIPTION	SIZE NO.	Q'TY
1	BOTTOM PAN		1	54	RETAINER		1
2	LEG (LEFT)		1	55	SPRING WASHER	M5	1
3	LEG (RIGHT)		1	56	ROUND HD. SCREW	M5x8	1
4	SKIRT		1	57	HEX. HD. SCREW	5/16x5/8	2
5	SHELF		1	58	SPRING WASHER	5/16	2
10	SWITCH BRACKET		1	58-1	WASHER	5/16	2
11	TOGGLE SWITCH		1	59	SUPPORT PLATE		1
12	ELECTRICAL BOX		1	60	STOP SCREW		1
13	HEX. HD. SCREW	5/16x3/4	8	61	NUT	5/16	2
14	SPRING WASHER	5/16	8	62	HEX. HD. SCREW	3/8x1	1
15	WASHER	5/16	8	63	NUT	3/8	1
16	SPRING WASHER	5/16	8	64	90° SUPPORT		1
17	NUT	5/16	8	65	NUT	3/8	2
18	HEX. HD. SCREW	5/16x1/2	6	66	SPRING WASHER	3/8	2
19	NUT	5/16	6	70	HEX. HD. SCREW	3/8x1-1/2	2
20	CYLINDER		1	71	HEX. HD. SCREW	5/16x3/4	1
21	HEX. SOC. SCREW	M10x40	1	72	THUMB SCREW		1
22	WASHER	3/8	1	73	STOP BLOCK		1
23	SPRING WASHER	M10	1	74	STOCK STOP ROD		1
24	NUT	M10	1	75N	FIBER HEX. NUT	1/2	2
25	HEX. HD. SCREW	3/8x1	2	76	WASHER	1/2	2
26	SPRING WASHER	3/8	2	80N	SUPPORT SHAFT	22mm	1
27	SUPPORT ROD		1	81	PIVOT ARM		1
28	HEX. HD. SCREW	1/4x3/8	1	80-1	BUSHING		1
29	BOTTOM SUPPORT		1	84	PLATE		1
33	WASHER		4	85	SPRING WASHER	3/8	2
34	WHEEL	5"	4	86	HEX. HD. SCREW	3/8x1-1/2	2
35	WHEEL SHAFT		2	87	SPRING		1
36	CUTTER PIN		4	88	SPRING ADJUSTING ROD		1
37	TOGGLE SWITCH		1	89	SPRING BRACKET		1
38	ELECTRIC CORD ASSEMBLY		1	90	HEX. HD. SCREW	5/16x1	1
39	TABLE		1	91	NUT	3/8	2
40	HEX. HD. SCREW	5/16x1	5	92	SPRING WASHER	5/16	1
41	WASHER	5/16	5	92-1	WASHER	5/16	1
42	SPRING WASHER	5/16	5	93	NUT	5/16	1
43	NUT	5/16	5	94	FRONT VISE		1
44	FILTER		1	95	REAR VISE		1
45	HEX. HD. SCREW	3/16x3/8	2	96	VISE THRUST SHAFT		1
46	ELECTRIC BOX ASSEMBLY		1	96-1	SPRING WASHER	3/8	2
47	HANDLE WHEEL		1	96-2	WASHER	3/8	1
48	HEX. HD. SCREW	5/16x3/8	1	97	HEX. HD. SCREW	3/8x1-1/2	1
49	KEY	5x20	1	98	HEX. HD. SCREW	1/2x1-1/2	1
50	LEAD SCREW		1	98-1	SPRING WASHER	1/2	2
51	NUT SEAT		1	98-2	WASHER	1/2	1
52	ACME NUT		1	99	HEX. HD. SCREW	1/2x1-1/4	1
53	BUTTON		1	100	SCALE		1

1040723

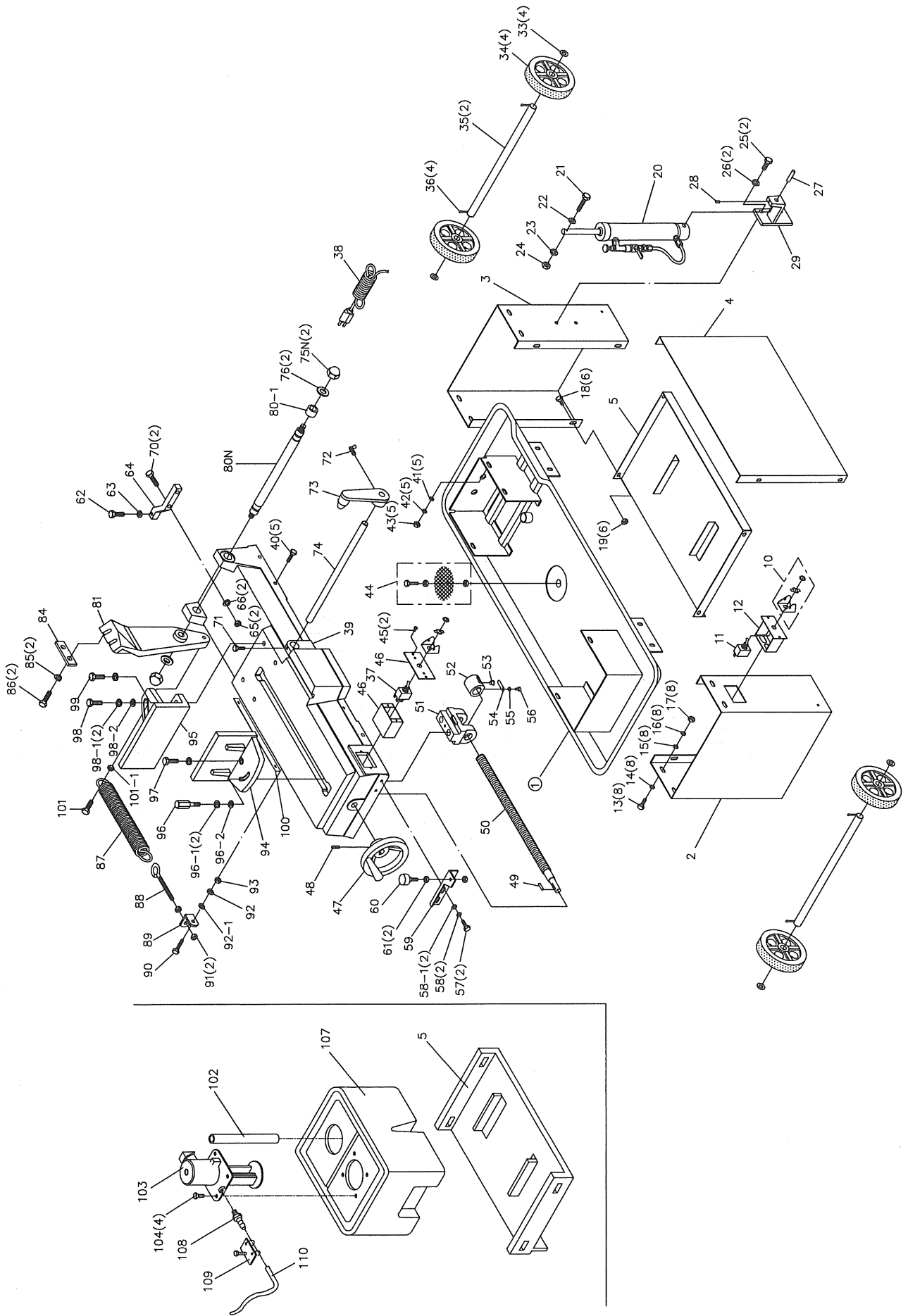

## PART LIST

PART NO.	DESCRIPTION	SIZE NO.	Q'TY	PART NO.	DESCRIPTION	SIZE NO.	Q'TY
101	HEX. SOC. SCREW	3/8x1-3/4	1	150	BRUSH HOLDER		1
102	HOSE		1	153	BRUSH		1
101-1	NUT	3/8	1	156	NOZZLE COCK		1
103	PUMP		1	157	SET SCREW	1/4x3/8	1
104	HEX. HD. SCREW	1/4x1/2	4	158	NOZZLE COCK SUPPORT		1
107	COOLANT TANK		1	159	VALVE		1
108	HOSE FITTING		1	160	ROUND HD. SCREW	3/16x3/8	2
109	HOSE CLAMP		1	161	HEX. SOC. SCREW	5/16x1-1/8	1
110	HOSE		1	161-1	SPRING WASHER	5/16	1
111	SAW BOW		1	163	ADJUSTABLE BRACKET (FRONT)		1
117	KEY	6x20	1	164	BLADE GUARD		1
119	HEX. HD. SCREW	3/8x7/8	1	164-1	ROUND HD. SCREW	3/16x1/4	2
119-1	SPRING WASHER	3/8	1	165	HEX. HD. SCREW	1/4x1/2	4
119-2	WASHER	3/8x35x4	1	166	SLIDING GUIDE PLATE		2
121N	GEAR BOX		1	167	SET SCREW	5/16x3/4	1
122	SPRING WASHER	5/16	4	168	HEX. HD. SCREW	5/16x1-1/2	2
123	HEX. HD. SCREW	5/16x1-1/4	4	169	BLADE TENSION SLIDING BLOCK		1
123-1	ADJ. SCREW	1/4x3/8	2	170	HEX. HD. SCREW	1/4x1/2	1
124	BLADE WHEEL (REAR)		1	170-1	SPRING WASHER	1/4	1
126	VENT PLUG		1	170-2	WASHER	1/4	1
127	BLADE		1	171	SLIDING DRAW BLOCK		1
128	BLADE BACK COVER		1	172	BRACKET		1
129	WHEEL COVER		1	173	BEARING BUSHING		1
130	PLUM SCREW		2	174	BALL BEARING	6203ZZ	2
130-1	WASHER	1/4	2	175	BLADE WHEEL (FRONT)		1
131	GUIDE ADJUSTABLE KNOB		2	176	WASHER	5/16	1
132	ADJUSTABLE BRACKET (REAR)		1	176-1	SPRING WASHER	5/16	1
133	BALL BEARING	608ZZ	2	177	HEX. HD. SCREW	5/16x3/4	1
134	BLADE ADJUSTABLE SEAT (REAR)		1	178	ROUND HD. SCREW	1/4x1/2	2
135	BEARING PIN		2	179	WASHER	1/4	2
136	ECCENTRIC SHAFT ASSEMBLY		2	180	WASHER	3/8	1
136-1	CENTER SHAFT ASSEMBLY		2	181	BLADE ADJUSTABLE HANDLE		1
137	NUT	3/8X24UNF	4	182	VERTICAL CUTTING PLATE		1
137-1	SPRING WASHER	3/8	4	192	MOTOR		1
138	WASHER	3/8	2	193	KEY	5mm	1
139	SPRING WASHER	3/8	2	194	WORM SHAFT		1
140	HEX. SOC. SCREW	5/16x1-1/8	1	195	HEX. SOC. SCREW	M6x20	1
141	HD. SCREW	1/4x1/2	2	196	GEAR SPACER		1
142	VERTICAL CUTTING PLATE (SMALL)		1	197	HEX. HD. SCREW	M8x20	2
143	BLADE ADJUSTABLE SEAT (FRONT)		1	198	SPRING WASHER	M8	2
144	HEX. HD. SCREW	3/8x1-1/4	2	204	HEX. HD. SCREW	1/4X1/2	2
145	TOP SUPPORT		1	205	WASHER	1/4	2
146	SPRING WASHER	3/8	2	206	SUPPORT PLATE		1
147	NUT	3/8	2				
148	ROUND HD. SCREW	1/4x1/2	2				
149	WASHER	1/4	2				

1040723



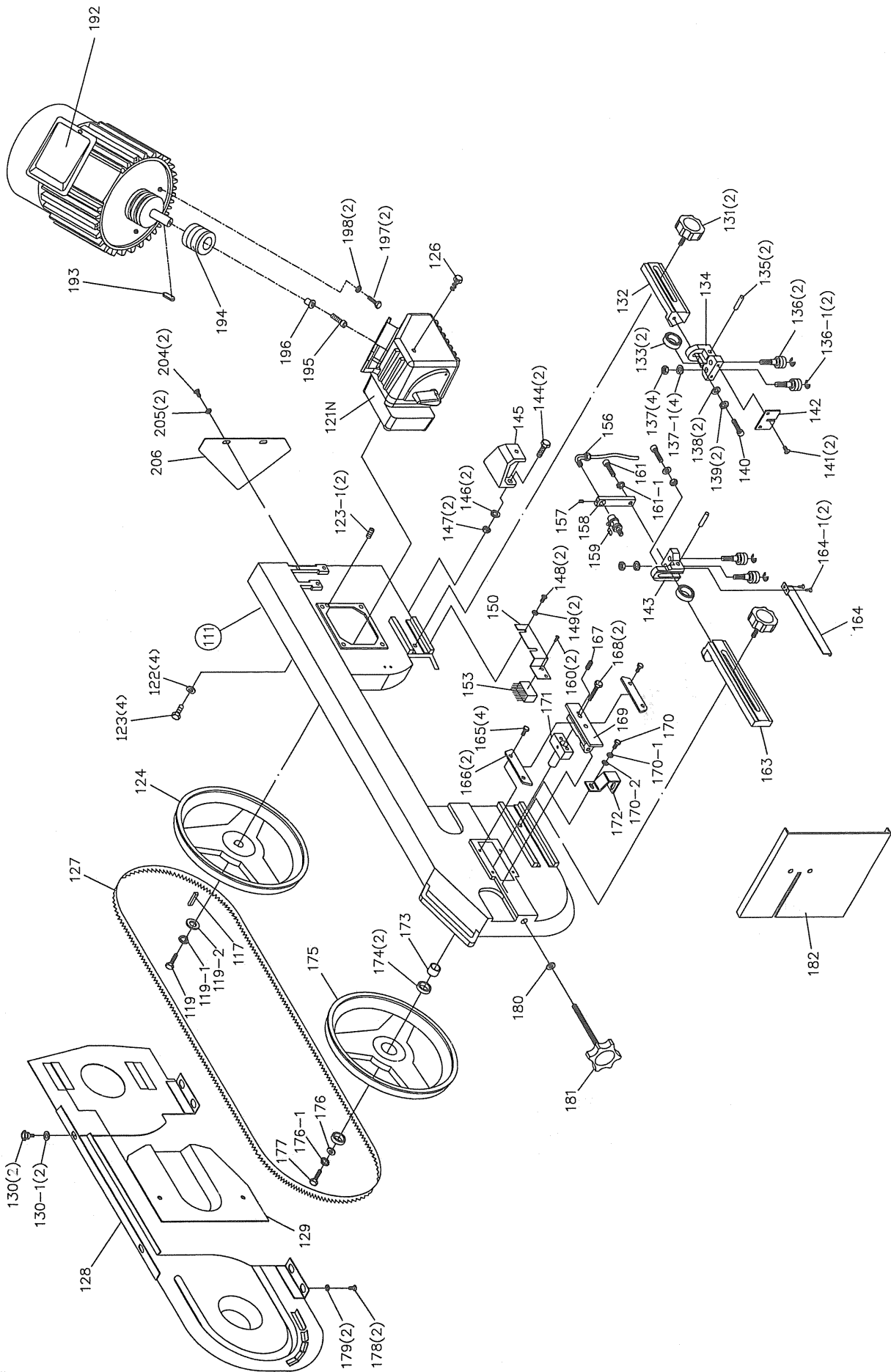

**2 YEAR  
LIMITED WARRANTY**

**JET offers a two year limited  
warranty on this product**

#### **MACHINERY WARRANTY**

JET makes every effort to assure that its products meet high quality standards and warrants to the retail consumer/purchaser of our products that each product is free from defects in material and workmanship as follows: **2 YEAR LIMITED WARRANTY ON THIS JET PRODUCT.** Warranty does not apply to defects due directly or indirectly to misuse, abuse, negligence or accidents, repairs or alterations performed outside our facilities or to a lack of maintenance. To take advantage of this warranty, the product or part must be returned freight prepaid to an authorized service station designated by our Vancouver office. Proof of purchase date and an explanation of the problem must accompany the merchandise. If our inspection discloses a warrantable defect JET will repair or replace the product at our option.

#### **PROOF OF PURCHASE**

Please retain your dated sales receipt as proof of purchase to validate the warranty period.

**Model:**

**Serial No:**

**Company:**

**Address:**

**Year of Construction:**

**(Please write down Serial No. from machine)**