

## OPERATOR'S MANUAL 1 Ton Heavy-Duty Hydraulic Low-Profile Transmission Jack



### IMPORTANT

For your safety, read, understand, and follow the information provided with and on this jack. The owner and operator of this equipment should understand this jack and the safe operating procedures before attempting to use. The owner and operator should be aware that use and repair of this product may require special skills and knowledge.

**Inspect before each use.** Do not use if broken, bent, cracked, or damaged parts are noted. Any jack that appears damaged in any way or operates abnormally should be removed from service immediately. If the jack has been or suspected to have been subjected to a shock load (a load dropped suddenly or unexpectedly on it), immediately discontinue use until the jack has been checked by a factory authorized service center. It is recommended that an annual inspection be performed by qualified personnel.

## 1. SAFETY INSTRUCTIONS AND WARNINGS

- 1.1 Read and understand all operating instructions before use.
- 1.2 The vehicle must be properly supported and blocked before starting repairs.
- 1.3 Use a transmission jack of the proper size and capacity to handle the anticipated load.
- 1.4 This jack is tarred for a maximum load of 2,000 lb. Do not overload beyond the jack's rated capacity. Overloading may cause damage to or failure of the jack.
- 1.5 Keep hands, fingers, and arms away from moving parts of the jack.
- 1.6 Secure the load with the safety chain before lowering or moving the load.
- 1.7 Lower the load slowly and avoid sudden starts or stops that may cause the load to shift.
- 1.8 This jack is designed for use on hard, level surfaces capable of sustaining the load. Use on other than hard level surfaces can result in jack instability and possible loss of load.
- 1.9 Do not use the transmission jack if under the influence of alcohol or drugs.
- 1.10 This transmission jack is designed and intended for use by properly trained and experienced personnel only. If you are not familiar with the proper and safe operation of a transmission jack, do not use until proper training and knowledge have been obtained.
- 1.11 The use of this jack is limited to the removal, installation, and transportation in the lowered position, of transmission and differentials.
- 1.12 Failure to comply with all warnings may cause loss of load, damage to the jack, and/or failure of the jack resulting in serious injury and/or property damage.

## 2. SPECIFICATIONS

Capacity	2,000 lb
Minimum Height	8.03"
Maximum Height	30.5"
Sideways Adjustment L/R	10°/15°
Saddle Size	7.87" x 7.08"
Base Size (L*W)	36.6" x 22.75"
Net weight	149.91 lb
Shipping Weight	165.35 lb

## 3. ASSEMBLY

**Refer to the exploded view drawing in the manual to identify part numbers in brackets.**

- 3.1 Loosely assemble the finger bases (#95) to the saddle plate (#92) with the hardware provided
- 3.2 Secure the end link of the chains (#91) to the fingers (#92). Connect the bolt (#87) to the saddle plate (#92) with the hardware (#86 & #87) provided.
- 3.3 Slide the hook (#100) through the bolts (#89) and secure it with the wing nut (#98).

**Note: Air may have been trapped during transportation and handling of the jack.  
Air may need to be purged from the system prior to use.**

### **PURGING AIR FROM THE HYDRAULIC SYSTEM:**

- a. Rotate the release knob (#33) at the top of the hydraulic block in a clockwise direction until tight. Now turn it in a counterclockwise direction two full turns.
- b. Activate the pump handle about 15 times
- c. Rotate the knob at the top of the hydraulic block in a clockwise direction until tight.
- d. Activate the pump handle until the lift arm is raised to maximum height. You should experience a full pump stroke with each incremental pump.
- e. Repeat steps “a” through “d” until all air is purged from the system.

## 4. OPERATING INSTRUCTIONS

- 4.1 Lift the vehicle to the desired work height and support the vehicle in accordance with the lift manufacturer’s lifting and support procedure.
- 4.2 Position the transmission jack directly under the transmission.
- 4.3 Locate and close the release valve by turning the knob clockwise firmly.
- 4.4 Pump the handle until the center of the saddle reaches the to the center balance point of the transmission without touching the transmission.
- 4.5 Follow the vehicle manufacturer’s recommended procedure for removing the load as outlined in the vehicle service manual or repair guide.
- 4.6 Position the transmission on the saddle plate, resting against the angle plates
- 4.7 Secure the load with the chains provided while ensuring the load’s center of gravity is centered on the saddle and the load is stable before lowering the jack
- 4.8 Once the transmission has been secured and is stable slowly turn the jack’s release valve knob counterclockwise, never more than 1/2 full turn until the load is completely lowered.
- 4.9 Immediately transfer the load to an appropriate repair fixture.

Note: When not in use, store the equipment in a dry location with the jack fully retracted.

## 5. MAINTENANCE

**Important:** Use only high-grade hydraulic jack oil. Avoid mixing different types of fluid and **NEVER** use brake fluid, turbine oil, transmission fluid, motor oil or glycerin. Improper fluid can cause premature failure of the jack and the potential for sudden and immediate loss of load.

5.1 **Adding Oil:** With the saddle lowered, set the jack in its upright, level position. Remove oil filler plug/screw. (The oil should be within 3/8" from the top of the filler plug hole).

5.2 **Changing Oil:** With the saddle fully lowered, set the jack in an upright level position. Remove the oil filler plug/screw. Lay the jack on its side and drain the oil into a suitable container. Set the jack in its level upright position. Fill oil until just below the rim of the filler hole. Reinstall oil filler plug/screw.

5.3 **Lubrication:** A periodic coating of light lubricating oil to pivot points, axles and hinges will help prevent rust and assure that wheels, casters and pump assemblies move freely

5.4 **Cleaning:** Periodically check the ram for signs of rust or corrosion. Clean as needed and wipe with an oily cloth.

**Note:** Ensure the jack is inspected and maintained on an annual basis by a qualified technician.

## 6. TROUBLESHOOTING

Symptom	Possible Causes	Corrective Action
Jack does not lift.	<ol style="list-style-type: none"> <li>1. Release valve is open.</li> <li>2. Low/no oil in reservoir.</li> <li>3. Air-locked system.</li> <li>4. Load is above capacity of jack.</li> <li>5. Delivery valve and/or bypass.</li> <li>6. Packing worn out or defective.</li> </ol>	<ol style="list-style-type: none"> <li>1. Close release valve.</li> <li>2. Fill with oil and bleed system.</li> <li>3. Bleed system.</li> <li>4. Use correct equipment.</li> <li>5. Clean to remove dirt or foreign matter. Replace oil.</li> <li>6. Replace power unit.</li> </ol>
Jack lifts only partially.	<ol style="list-style-type: none"> <li>1. Too much or not enough oil.</li> </ol>	<ol style="list-style-type: none"> <li>1. Check oil level.</li> </ol>
Jack advances slowly.	<ol style="list-style-type: none"> <li>1. Pump not working correctly.</li> <li>2. Leaking seals.</li> </ol>	<ol style="list-style-type: none"> <li>1. Install seal kit or replace power unit.</li> <li>2. Install seal kit or replace power unit.</li> </ol>
Jack lifts load, but does not hold.	<ol style="list-style-type: none"> <li>1. Cylinder packing is leaking.</li> <li>2. Valve not working correctly.</li> <li>3. Air-locked system.</li> </ol>	<ol style="list-style-type: none"> <li>1. Install seal kit.</li> <li>2. Inspect valves. Clean and repair seat surfaces.</li> <li>3. Bleed system.</li> </ol>
Jack leaks oil.	<ol style="list-style-type: none"> <li>1. Worn or damaged seals.</li> </ol>	<ol style="list-style-type: none"> <li>1. Install seal kit.</li> </ol>
Jack will not retract.	<ol style="list-style-type: none"> <li>1. Release valve is closed.</li> </ol>	<ol style="list-style-type: none"> <li>1. Open or clean release valve.</li> </ol>
Jack retracts slowly.	<ol style="list-style-type: none"> <li>1. Cylinder damaged internally.</li> <li>2. Link section is binding.</li> </ol>	<ol style="list-style-type: none"> <li>1. Install seal kit.</li> <li>2. Lubricate link section.</li> </ol>

## 1 TON HEAVY-DUTY HYDRAULIC LOW-PROFILE TRANSMISSION JACK

PROD. NO. 030546  
MOD. NO. 806B

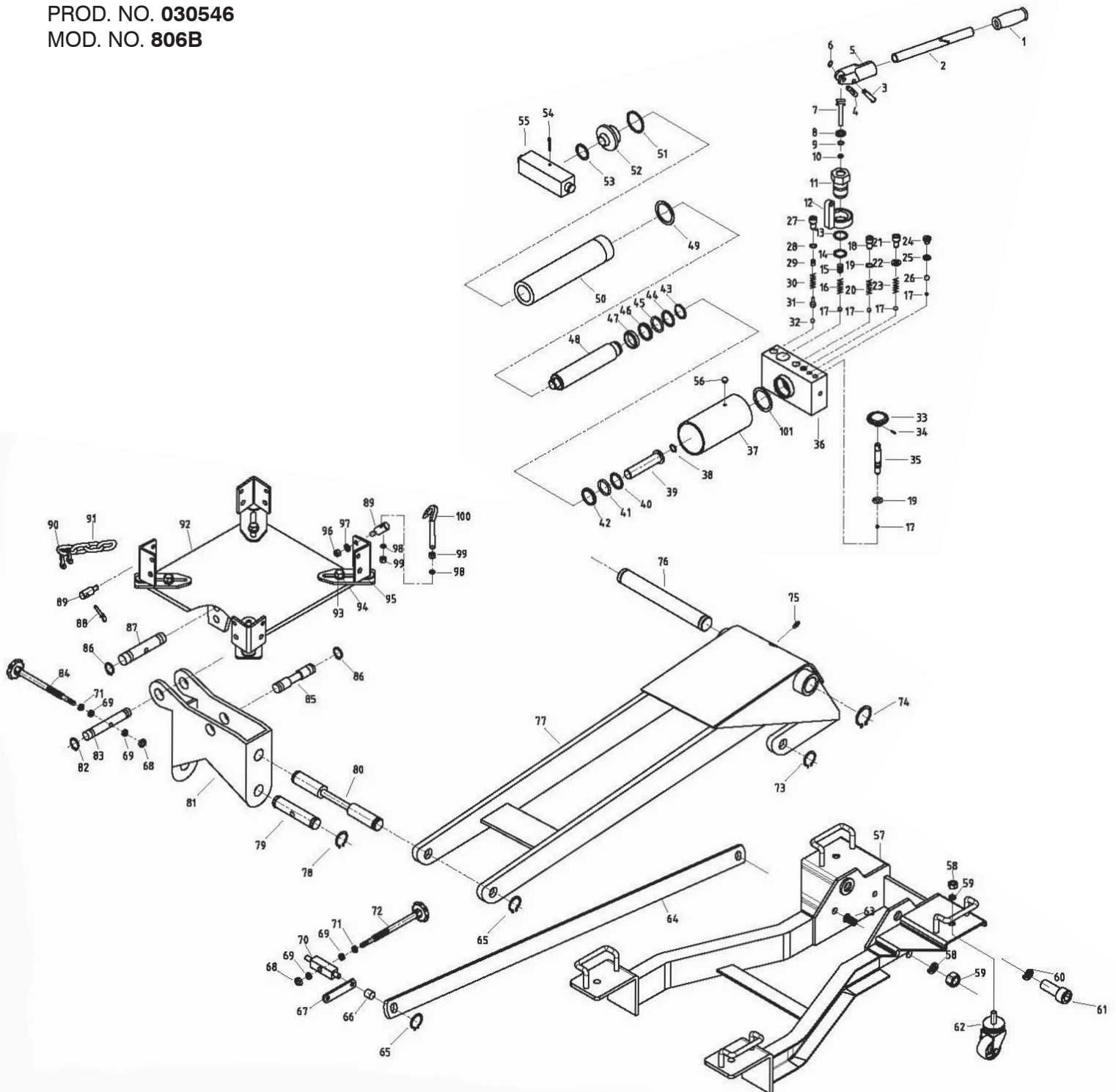

# 1 TON HEAVY-DUTY HYDRAULIC LOW-PROFILE

## TRANSMISSION JACK

PROD. NO. 030546 MOD. NO. 806B

REF	PART NUMBER	DESCRIPTION	REQ	REF	PART NUMBER	DESCRIPTION	REQ
1	PCN-806B-01	HANDLE GRIP	1	52	PCN-806B-52	TOP CAP	1
2	PCN-806B-02	HANDLE, BLACK	1	53	PCN-806B-53	O-RING	1
3	PCN-806B-03	BOLT M8*16	1	54	PCN-806B-54	PIN 5X45	1
4	PCN-806B-04	PIN	1	55	PCN-806B-55	CONNECTING ROD	1
5	PCN-806B-05	BRACKET	1	56	PCN-806B-56	OIL PLUG	1
6	PCN-806B-06	WASHER 9	1	57	PCN-806B-57	FRAME ASSEMBLY	1
7	PCN-806B-07	PUMP PLUG	1	58	PCN-806B-58	NUT M16	6
8	PCN-806B-08	COPPER WASHER	1	59	PCN-806B-59	WASHER M16	6
9	PCN-806B-09	WASHER	1	60	PCN-806B-60	WASHER M12	2
10	PCN-806B-10	O-RING	1	61	PCN-806B-61	SCREW M12X40	2
11	PCN-806B-11	PUMP	1	62	PCN-806B-62	UNIVERSAL WHEEL	4
12	PCN-806B-12	BRACKET	1	63	PCN-806B-63	ROD PIN	2
13	PCN-806B-13	O-RING	1	64	PCN-806B-64	CONNECTING ROD	2
14	PCN-806B-14	COPPER WASHER	1	65	PCN-806B-65	WASHER M16	4
15	PCN-806B-15	SCREW	1	66	PCN-806B-66	SHAFT SLEEVE	2
16	PCN-806B-16	SPRING	1	67	PCN-806B-67	CONNECTING ROD	2
17	PCN-806B-17	STEEL BALL	1	68	PCN-806B-68	NUT M10	2
18	PCN-806B-18	SCREW	1	69	PCN-806B-69	PIN	4
19	PCN-806B-19	O-RING	1	70	PCN-806B-70	CONNECTING ROD SHAFT	1
20	PCN-806B-20	SPRING	1	71	PCN-806B-71	WASHER	2
21	PCN-806B-21	SCREW	1	72	PCN-806B-72	HANDLE ASSEMBLY	1
22	PCN-806B-22	WASHER	1	73	PCN-806B-73	RETAINING RING	2
23	PCN-806B-23	LOW PRESSURE SPRING	1	74	PCN-806B-74	RETAINING RING	2
24	PCN-806B-24	SCREW	1	75	PCN-806B-75	GREASE FITTING	1
25	PCN-806B-25	WASHER	1	76	PCN-806B-76	ARM SHAFT	1
26	PCN-806B-26	STEEL BALL	1	77	PCN-806B-77	LIFT ARM	1
27	PCN-806B-27	SAFETY VALVE SCREW	1	78	PCN-806B-78	RETAINING RING	2
28	PCN-806B-28	SAFETY VALVE O-RING	1	79	PCN-806B-79	FRONT AND REAR NUT SHAFT	1
29	PCN-806B-29	REGULATE SCREW	1	80	PCN-806B-80	ADJUSTING SHAFT	1
30	PCN-806B-30	SAFETY VALVE SPRING	1	81	PCN-806B-81	ADJUSTING SEAT	1
31	PCN-806B-31	BALL VALVE SEAT	1	82	PCN-806B-82	RETAINING RING	2
32	PCN-806B-32	STEEL BALL	1	83	PCN-806B-83	LEFT AND RIGHT NUT SHAFT	1
33	PCN-806B-33	HANDLE	1	84	PCN-806B-84	HANDLE ASSEMBLY	1
34	PCN-806B-34	PIN 5X24	1	85	PCN-806B-85	ADJUSTING SHAFT	1
35	PCN-806B-35	RELEASE ROD	1	86	PCN-806B-86	RETAINING RING	4
36	PCN-806B-36	VALVE BODY	1	87	PCN-806B-87	ADJUSTING SHAFT	1
37	PCN-806B-37	COVER	1	88	PCN-806B-88	BOLT	1
38	PCN-806B-38	O-RING	1	89	PCN-806B-89	SCREW	2
39	PCN-806B-39	FIXED PISTON ROD	1	90	PCN-806B-90	HOOK	4
40	PCN-806B-40	RETAINING RING	1	91	PCN-806B-91	CHAIN	2
41	PCN-806B-41	O-RING	1	92	PCN-806B-92	PALLET ASSEMBLY	2
42	PCN-806B-42	Y-RING	1	93	PCN-806B-93	BOLT M12X20	1
43	PCN-806B-43	RETAINING RING	1	94	PCN-806B-94	WASHER M12	4
44	PCN-806B-44	WASHER	1	95	PCN-806B-95	BRACKET	4
45	PCN-806B-45	O-RING	1	96	PCN-806B-96	NUT M10	4
46	PCN-806B-46	WASHER	1	97	PCN-806B-97	WASHER M10	4
47	PCN-806B-47	O-RING	1	98	PCN-806B-98	NUT M8	4
48	PCN-806B-48	PISTON ROD	1	99	PCN-806B-99	WASHER M8	4
49	PCN-806B-49	O-RING	1	100	PCN-806B-100	HOOK	4
50	PCN-806B-50	CYLINDER	1	101	PCN-806B-101	O-RING	2
51	PCN-806B-51	O-RING	1				