

# Adjustable Height Under-Hood Steel Tool Tray – 220 lb Capacity

Prod. No. **843016**  
Mod. No. **JUHT-220S**

## SPECIFICATIONS

<b>Overall Tray Dimensions</b>	28.875" x 19.875" x 1"
<b>Main Tray Area</b>	28.5" x 16.875" x 1"
<b>Small Compartments</b>	9.5" x 2.75" x 1"
<b>Gauge Steel</b>	1.5 mm
<b>Low Height</b>	34"
<b>High Height</b>	47.75"
<b>Overall Length</b>	32.75"
<b>Overall Width</b>	20.375"
<b>Shipping Weight</b>	39.7 lbs

## TOOLS NEEDED TO ASSEMBLE UNIT

17 and 14 mm Wrench

## ASSEMBLY & INSTALLATION

- Using four 14 mm bolts, washer, and nuts, install one caster in each square hole on the bottom edge support (#7 and #11). Be sure the square bolster on the post of each caster inserts fully into the square hole in the support before fully tightening.
- Using four 14 mm bolts and washers, attach the bolt plate on the right support (#7) to the bracket on the tube support (#10), ensuring that the casters are facing down. Be sure bolts are securely tightened before proceeding.
- Slide left support tube (#11) into the tube support (#10) and secure with 17 mm bolt and curved washer (#12). The curved washer should conform to the tubing wall.
- Laying the top tray (#1) upside down on the floor, attach the mounting bracket on silver adjusting tube (#5) to the bracket on the bottom of the tray, being sure the adjusting tube faces AWAY from the center of the top tray.
- Now, slide the silver adjusting tube with top tray attached into the tube support (#10) and secure at the desired height with the T-bolt (#6).
- Attach four rubber protector bumpers (#2) by pushing the black plastic pins provided into the holes in the corners of the top tray. The pins are inserted from OUTSIDE the tray toward the inside, being sure the rubber bumpers overlap the top edge of the tray.
- Install the four small rectangular plastic inserts (#3) into the reinforcement bars under top tray. Install the four large rectangular plastic inserts (#8) into the four holes on the left and right supports (#7 and #11).
- You are now ready to use your new JET JUHT-220S tool tray

A



Brand

surewerx.com

## CAUTION

DO NOT EXCEED THE 220 LB-RATED CAPACITY (100 KG)

## WARNING

Read and follow all instructions in User's Manual. • Do not load work table beyond rated capacity (220 lbs.) • Apply brake on locking casters anytime cart is in place. • Work table is designed to roll easily on flat surfaces and should not be used on uneven or inclined surfaces. • Do not stand on work table. • Do not pull work table. • Work table can tip or fall causing damage or injury. • Keep children away from work table • Wear gloves when lifting by edges • Failure to heed these warnings may result in personal injury and/or property damage.

## PARTS BREAKDOWN

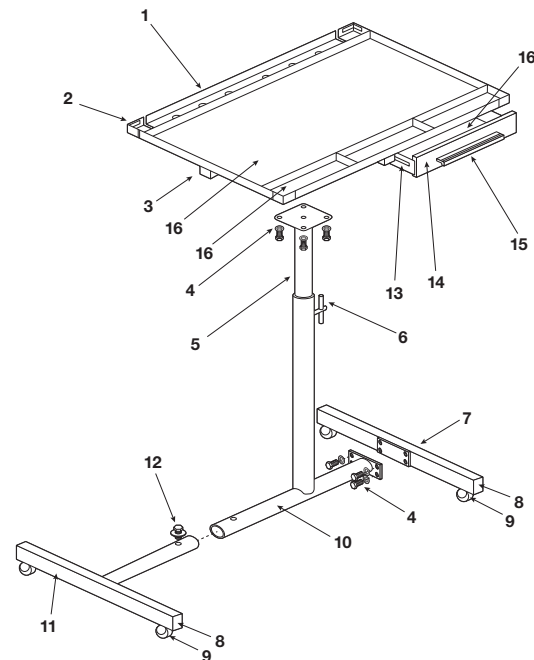

REF	DESCRIPTION	QTY	REF	DESCRIPTION	QTY
1	Top Tray with Rubber Liner	1	9	3" Caster with Nut	4
2	Rubber Corner Bumper w/Pins	4	10	Tube Support	1
3	Small Plastic Insert	3	11	Left Support	1
4	Hardware Kit*	1	12	Hardware Kit*	1
5	Adjustable Tube (Silver)	1	13	Ball Bearing Slide (Pair)	1
6	T-Bolt	1	14	Drawer Unit (with EVA Pad)	1
7	Right Support	1	15	Aluminum Handle	1
8	Large Plastic Insert	4	16	Pad Set	5

\* #4 & #12 hardware kit includes 14 mm bolt with washer (8 pcs) & 17 mm bolt w/curved washer