

OPERATING INSTRUCTIONS - 030352, 030353 - Engine Stands

Important: read these instructions and all warnings prior to using this equipment. Understand all operating procedures, safety warnings and maintenance requirements. Failure to do so could cause an accident resulting in serious or fatal injury and/or personal property damage.

Warning

The use of shop equipment is subject to certain hazards that cannot be prevented by mechanical means, but only by exercise of intelligence, care, and common sense. It is therefore essential to have personnel involved in the use and operation of equipment who are careful, competent, trained, and qualified in the safe operation of this equipment and its proper use. Examples of hazards are dropping, tipping, or slipping of parts/components caused primarily by improperly securing loads, overloading, off-centered loads, use on other than hard level surfaces, and using equipment for a purpose for which it was not designed.

The owner and / or operator shall study and understand the product and safety instructions before operating this equipment. Safety information shall be emphasized and understood. If the operator is not fluent in English, the product and safety instructions shall be read to and discussed with the operator in the operator's native language by the purchaser / owner or his designee, making sure that the operator comprehends their contents. A copy of these instructions / warnings shall be retained for future reference.

Inspection

Visual inspection shall be made before each use of this equipment, checking for abnormal conditions, such as cracked welds, leaks, damaged, loose or missing parts. This equipment shall be removed immediately from service if it is believed to have been subjected to an abnormal or shock load, the equipment shall be inspected by a qualified repair facility. Owners and / or operators should be aware that repair of this equipment may require specialized knowledge and facilities. It is recommended that this equipment be inspected annually by a qualified repair facility. Defective parts, decals, safety labels or signs should be replaced with Strongarm specified parts.

Warning

- When using various shop equipment, basic safety precautions should always be followed.
- Keep work area clean and free from debris.
- Keep children away from work area and shop equipment. Keep hands and feet from loading area.
- Study, understand, and follow all instructions before operating this device.
- Do not exceed rated capacity.
- Use only on a hard level surface.
- Do not work underneath the engine when being lifted or suspended.
- Lock mounting plate rotating mechanism before applying a load.
- Ensure load is centered and secured to mounting attachments.
- Off-center loads may make the load and handle rotate in either direction when the rotational locking device is released.
- Release rotational locking device slowly and carefully.
- Only attachments and/or adapters supplied by the manufacturer shall be used.
- No alterations shall be made to this product.
- Failure to heed these instructions may result in personal injury and/or property damage.

Assembling

Minor assembly of this unit is needed. Use the parts drawing as your guide to assembly. Lay all parts and assemblies out in front of you before beginning.

Mounting

1. Remove the engine from the vehicle using an appropriately rated Engine Crane or lifting device.
2. Remove the bell housing from the engine.
3. Remove or secure any loose engine components.
4. Remove the Mounting head assembly from the Engine Stand and attach to the engine referring to the vehicle or engine manufacturers' guidelines using Grade 5 bolts, ensuring the engine centre of gravity aligns properly with the rotational axis of the mounting head. Tighten bolts.
5. With the engine removed from the vehicle and the Engine Stand Mounting head centered and secured to the engine, align the mounting head assembly with the Engine Stand receiver tube and secure in place using the Locking Pin / Bolt.
WARNING – If the engine is not centered properly, the load and handle may rotate in either direction when the locking pin / bolt is removed.
6. Before disconnecting the engine from the Engine Crane or Lifting device, ensure the engine is secured firmly to the Engine Stand, and that the Rotational locking pin/bolt is tight and is stable.
7. Insert Handle through Mounting head assembly tube and secure.

OPERATING INSTRUCTIONS - 030352, 030353 - Engine Stands

Dismounting

1. Attach an appropriately rated Engine Crane or Lifting device, to the engine.
2. Slowly raise the engine to relieve the weight from the Engine Stand.
WARNING – If the engine is not centered properly, the load and handle may rotate in either direction when the locking pin / bolt is removed.
3. Remove the handle from the Mounting head
4. Slowly and carefully remove the Rotational Locking Pin / Bolt.
5. With the load secured to the Engine Crane or Lifting device, slowly separate the Mounting head assembly and Engine from the Engine Stand
6. Remove the Mounting head assembly from the engine.

Maintenance

Store Engine Stand in a clean and dry environment. Using a general purpose grease, lubricate wheels, casters, and mounting head assembly tube.

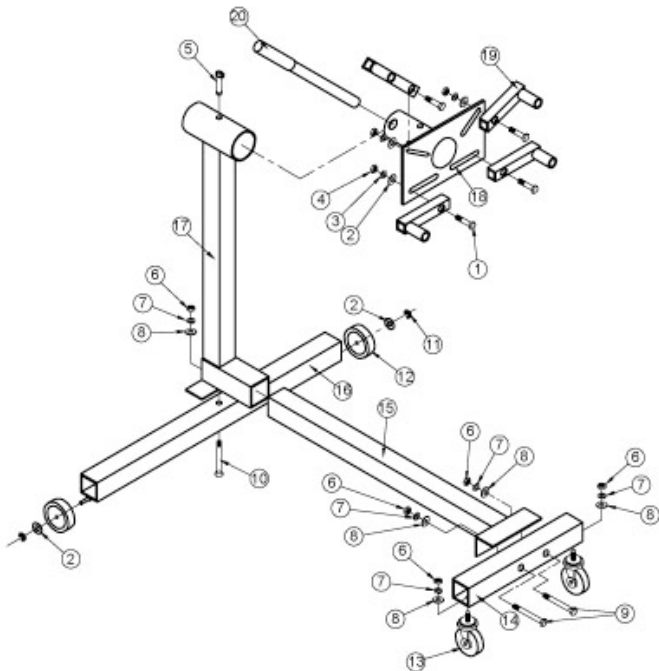

1,000 lb. Capacity 'H' Style Parts Breakdown

Part #	Description	Qty	Part #	Description	Qty
1	M14 x 60mm Bolt	4	11	Retaining Ring	2
2	M14 Washer	6	12	Wheel	2
3	M14 Lock Washer	4	13	Caster	2
4	M14 Nut	4	14	Front Beam	1
5	Locking Pin	1	15	Middle Beam	1
6	M12 Nut	5	16	Rear Beam	1
7	M12 Lock Washer	5	17	Main Post	1
8	M12 Washer	5	18	Mounting Head	1
9	M12 x 70mm Bolt	2	19	Bracket	4
10	M12 x 80mm Bolt	1	20	Handle	1

OPERATING INSTRUCTIONS - 030352, 030353 - Engine Stands

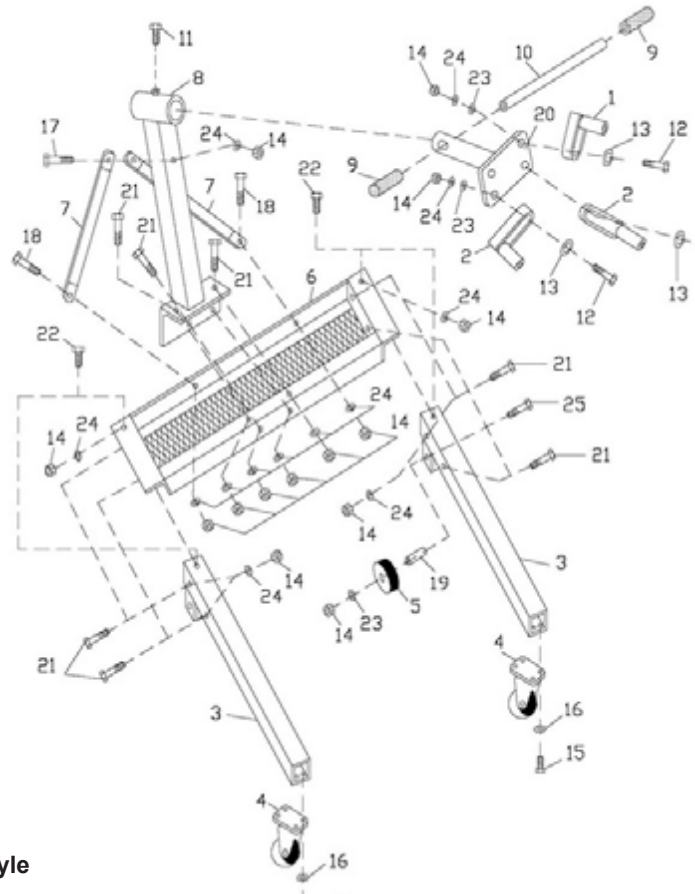

1,250 lb. Capacity 'U' Style Parts Breakdown

Part #	Description	Qty
1	Short Bracket	2
2	Long Bracket	2
3	Stand Legs (Left & Right)	2
4	3.5" Caster	2
5	4" Steel Wheel	2
6	Base	1
7	Strap	2
8	Main Post	1
9	Handle Grip	2
10	Handle	1
11	Locking Bolt M12 x 25	1
12	Hex Bolt M12 x 75, Grade 8.8	4

Part #	Description	Qty
13	Large Washer 12 (Thickness 4Mm)	4
14	Hex Nut M12	19
15	Hex Bolt M8 x 16	8
16	Lock Washer 8	8
17	Hex Bolt M12 x 90	1
18	Hex Bolt M12 x 90	2
19	Shaft Sleeve	2
20	Mounting Head	1
21	Hex Bolt M12 x 80	8
22	Hex Bolt M12 x 80	2
23	Lock Washer 12	6
24	Flat Washer 12	17
25	Hex Bolt M12 x 65	2