

Parts List & Operating Instructions

Operating Instructions

Brake Anchor Pin Removal and Installation

1. Remove all lock ring retainers from the brake anchor pins.
2. Position the C-frame press over the brake spider as shown in Figure 1.
3. Tighten the forcing screw until the anchor pin is removed.

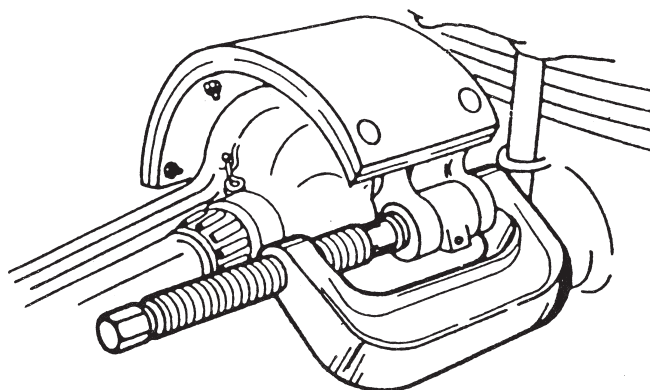

Figure 1

"U" Joint Assembly and Disassembly

The basic C-frame press is used to service the "U" joints on most cars and light trucks. The "U" joints can be serviced either on or off the vehicle.

Disassembly

1. Remove any external and / or internal lock rings.
2. Position the C-frame press around the drive shaft yoke, and tighten the forcing screw until the first bearing is removed.
3. Reposition the C-frame and remove the second bearing.

Assembly

1. Clean all dirt and oil from the yoke area.
2. Align the replacement bearing and C-frame press as straight as possible over the yoke. Press the replacement bearing into the yoke, and reassemble the external / internal lock ring.
3. Reposition the C-frame press and second replacement bearing as straight as possible over the yoke, and press the bearing into the yoke. Reassemble external / internal lock ring.

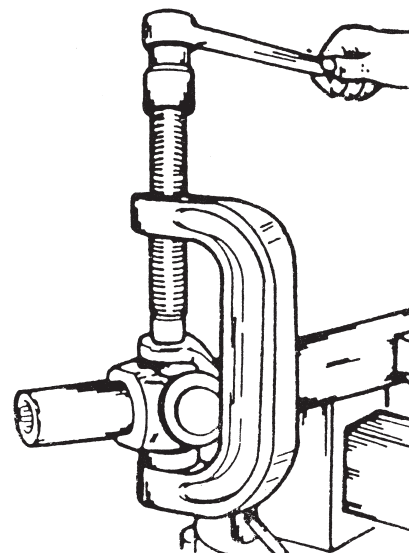

Figure 2

Parts List & Operating Instructions

Ball Joint Removal and Installation

This tool set is designed for use on all cars and light trucks that have press-fit type ball joints. It will help the user remove and install ball joints without the need to remove the control arm from the vehicle.

NOTE: Some cars and light trucks may have the upper ball joint spot-welded to the control arm. The weld must be cut before attempting to remove the ball joint.

Removal (Item numbers refer to the parts list on Sheet 1)

1. Assemble the ball joint press over the control arm as shown in Figure 3. Select the correct size receiving tube (Item 6, 7, or 8), and position it under the vehicle ball joint as shown.
2. Tighten the forcing screw until the receiving tube contacts the control arm. Check the alignment of all tooling and components, and continue tightening the forcing screw until the ball joint is removed.

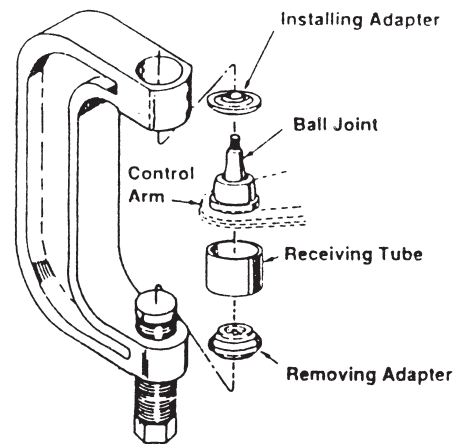

Figure 3

Installation

1. Clean the control arm and coat the I.D. with a suitable lubricant.
2. Insert the replacement ball joint as straight as possible into the vehicle control arm.
3. Assemble the ball joint press components as shown in Figure 4. Position the receiving tube, and tighten the forcing screw. Check the alignment of all tooling and components, and continue tightening the forcing screw until the ball joint is firmly seated.

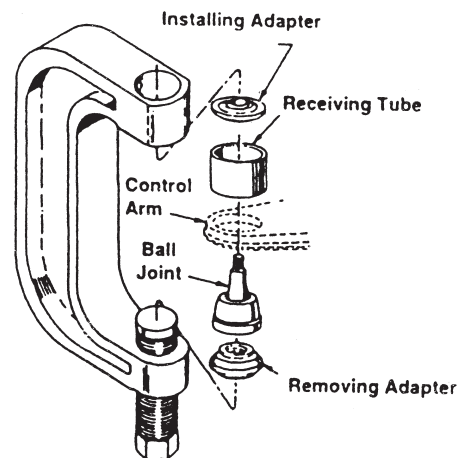
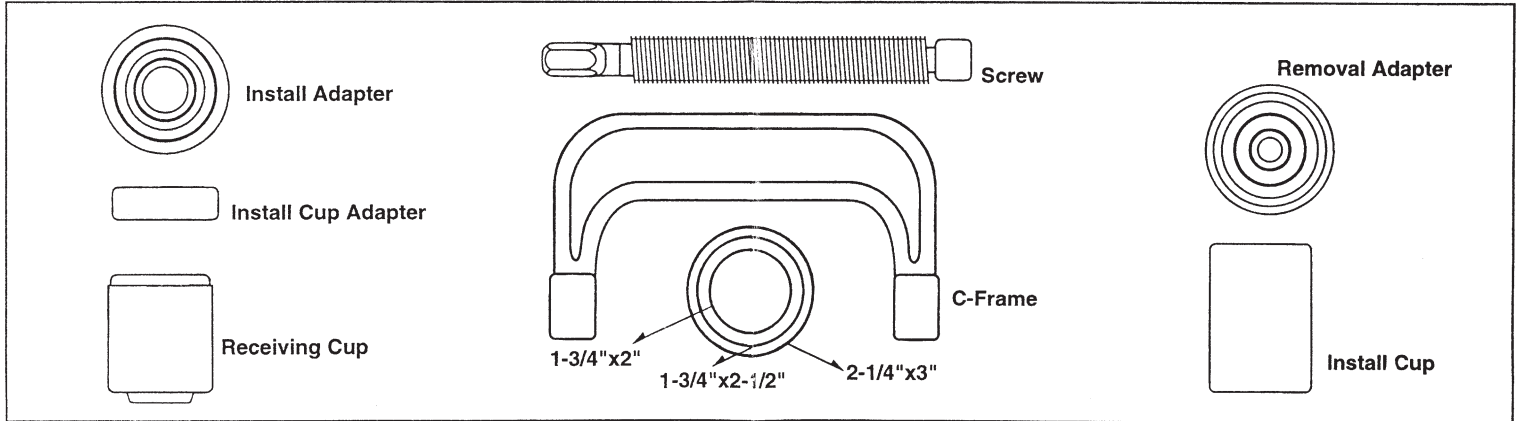

Figure 4

Ball Joint and Four Wheel Drive Service Set



Four wheel Drive Ball Joint Service Kit

Application: Used with Ball Joint Press & Service Tools (3-in-1 Service Set) to remove and install upper and lower ball joints on 1967 current 4WD vehicles with Dana 44 axles.

Parts List

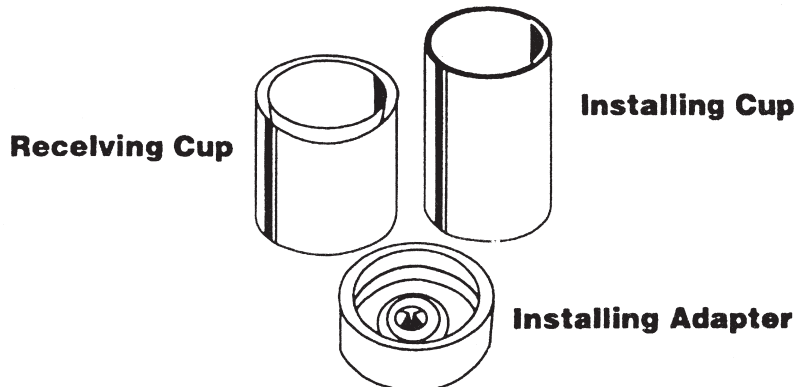

Safety Precautions

⚠ Caution: To help prevent personal injury

- Wear approved eye protection when using the tools in this kit.
- Before repairing a vehicle, block the wheels to prevent the vehicle from moving.
- Check the final alignment of the C-frame press and all tooling with components before exerting pressure to remove or replace a ball joint.