

## 3.5-TON FLOOR JACK – DUAL PISTON PUMP

PROD. NO. 030606

MOD. NO. 985GTO

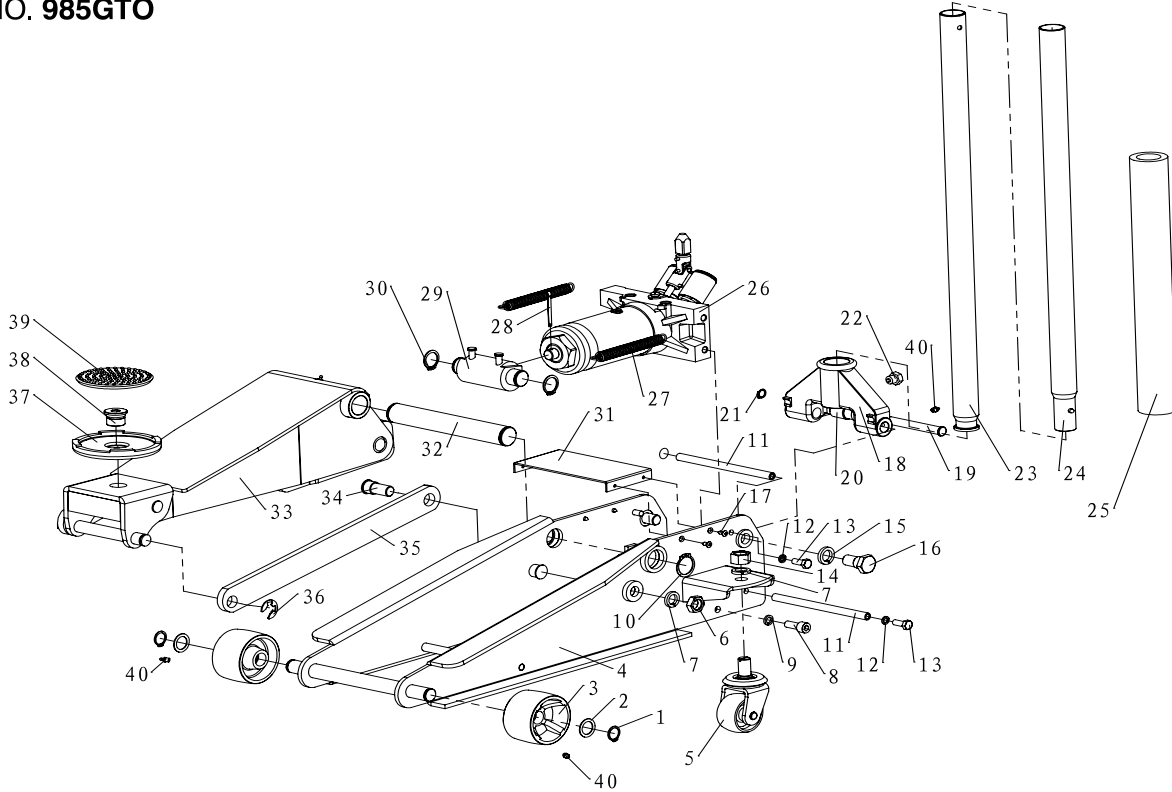

REF	PART NUMBER	DESCRIPTION	REQ	REF	PART NUMBER	DESCRIPTION	REQ
1	PFH-985GTO-01	RETAINING RING 20	2	21	PFH-985GTO-21	RETAINING RING 12	1
2	PFH-985GTO-02	WASHER	2	22	PFH-985GTO-22	SCREW	1
3	PFH-985GTO-03	FRONT WHEEL	2	23	PFH-985GTO-23	HANDLE LOWER	1
4	PFH-985GTO-04	JACK FRAME	1	24	PFH-985GTO-24	HANDLE UPPER	1
5	PFH-985GTO-05	REAR CAST	2	25	PFH-985GTO-25	HANDLE BUMPER	1
6	PFH-985GTO-06	NUT M16	2	26	PFH-985GTO-26	POWER UNIT	1
7	PFH-985GTO-07	SPRING WASHER 16	4	27	PFH-985GTO-27	SPRING	2
8	PFH-985GTO-08	SCREW M10X25	4	28	PFH-985GTO-28	SPLIT PIN 4X45	1
9	PFH-985GTO-09	SPRING WASHER 10	4	29	PFH-985GTO-29	BLOCK LINKAGE	1
10	PFH-985GTO-10	RETAINING RING 30	2	30	PFH-985GTO-30	RETAINING RING 25	2
11	PFH-985GTO-11	TIE ROD	2	31	PFH-985GTO-31	COVER PLATE	1
12	PFH-985GTO-12	SPRING WASHER 8	4	32	PFH-985GTO-32	SHAFT	1
13	PFH-985GTO-13	SCREW M8X20	4	33	PFH-985GTO-33	LIFT ARM	1
14	PFH-985GTO-14	NUT M16	2	34	PFH-985GTO-34	SUPPORT BAR BOLT	2
15	PFH-985GTO-15	SPRING WASHER 18	2	35	PFH-985GTO-35	SUPPORT BAR	2
16	PFH-985GTO-16	BOLT	2	36	PFH-985GTO-36	E RING 15	2
17	PFH-985GTO-17	SCREW ST4.8X13	4	37	PFH-985GTO-37	SADDLE	1
18	PFH-985GTO-18	HANDLE SOCKET	1	38	PFH-985GTO-38	SCREW	1
19	PFH-985GTO-19	ROLLER PIN	1	39	PFH-985GTO-39	SADDLE PAD	1
20	PFH-985GTO-20	ROLLER	1	40	PFH-985GTO-40	GREASE NIPPLE	5

## 3.5-TON FLOOR JACK – DUAL PISTON PUMP

PROD. NO. 030606

MOD. NO. 985GTO

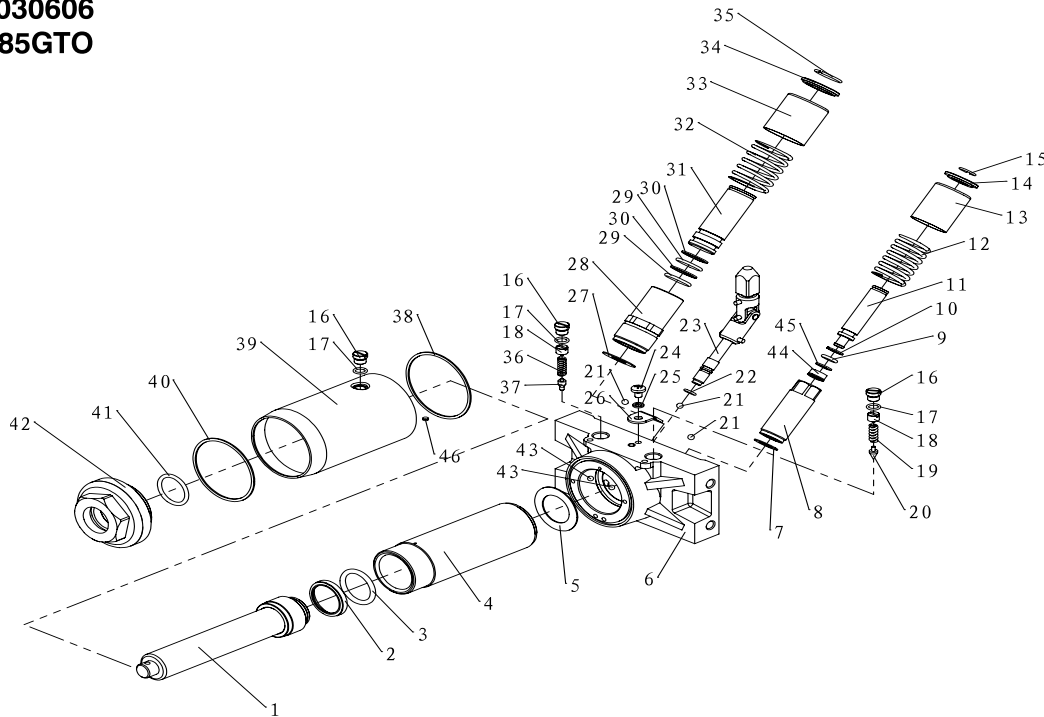

REF	PART NUMBER	DESCRIPTION	REQ	REF	PART NUMBER	DESCRIPTION	REQ
1	PFH-985GTO-PH1	RAM	1	25	PFH-985GTO-PH25	SPRING WASHER 6	1
2	PFH-985GTO-PH2	O-RING RETAINER	1	26	PFH-985GTO-PH26	PINCH PLATE	1
3	PFH-985GTO-PH3	O-RING	1	27	PFH-985GTO-PH27	SEAL WASHER	1
4	PFH-985GTO-PH4	CYLINDER	1	28	PFH-985GTO-PH28	BIGGER PUMP CASE	1
5	PFH-985GTO-PH5	SEAL WASHER	1	29	PFH-985GTO-PH29	O-RING 20X2.65	2
6	PFH-985GTO-PH6	POWER UNIT BASE	1	30	PFH-985GTO-PH30	BACKUP	2
7	PFH-985GTO-PH7	SEAL WASHER	1	31	PFH-985GTO-PH31	BIGGER PLUNGER	1
8	PFH-985GTO-PH8	PUMP CASE	1	32	PFH-985GTO-PH32	SPRING	1
9	PFH-985GTO-PH9	O-RING 10X2.65	1	33	PFH-985GTO-PH33	BIGGER BUSHING	1
10	PFH-985GTO-PH10	BACKUP	1	34	PFH-985GTO-PH34	BIGGER PUMP COVER	1
11	PFH-985GTO-PH11	PLUNGER	1	35	PFH-985GTO-PH35	RING 25	1
12	PFH-985GTO-PH12	SPRING	1	36	PFH-985GTO-PH36	RELIEF VALVE SPRING	1
13	PFH-985GTO-PH13	BUSHING	1	37	PFH-985GTO-PH37	SAFETY VALVE	1
14	PFH-985GTO-PH14	PUMP COVER	1	38	PFH-985GTO-PH38	NYLON WASHER LOWER	1
15	PFH-985GTO-PH15	RING	1	39	PFH-985GTO-PH39	CYLINDER OUTER CASE	1
16	PFH-985GTO-PH16	SCREW	3	40	PFH-985GTO-PH40	NYLON WASHER UPPER	1
17	PFH-985GTO-PH17	O-RING 8.5X1.8	3	41	PFH-985GTO-PH41	O-RING 36X3.5	1
18	PFH-985GTO-PH18	SCREW ADJUSTING	2	42	PFH-985GTO-PH42	TANK NUT	1
19	PFH-985GTO-PH19	RELIEF VALVE SPRING	1	43	PFH-985GTO-PH43	BALL 5	2
20	PFH-985GTO-PH20	SAFETY VALVE	1	44	PFH-985GTO-PH44	U-SEAL	1
21	PFH-985GTO-PH21	BALL 5.5	3	45	PFH-985GTO-PH45	BACKUP	1
22	PFH-985GTO-PH22	O-RING 8X1.8	1	46	PFH-985GTO-PH46	MAGNET	1
23	PFH-985GTO-PH23	RELEASE VALVE	1	XX	PFH-985GTO-PHRK	REPAIR KIT	1
24	PFH-985GTO-PH24	SCREW M6X8	1				