

PROD. NO. 030256
MOD. NO. BRK-20SHD

OPERATOR'S MANUAL Hydraulic Body/Frame Repair Kit

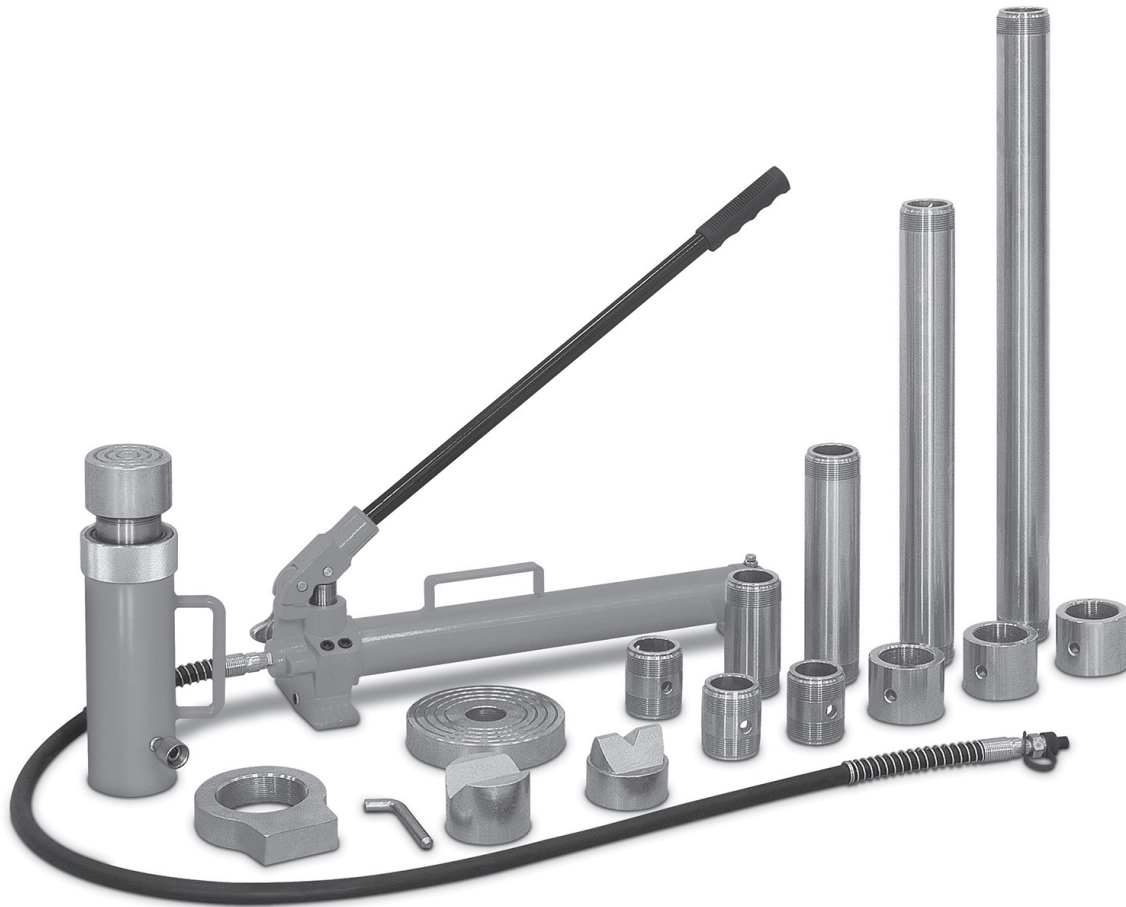

WARNING:

FOR YOUR SAFETY, PLEASE READ THESE INSTRUCTIONS CAREFULLY. THE OWNER AND OPERATOR SHALL HAVE AN UNDERSTANDING OF THIS PRODUCT AND SAFE OPERATING PROCEDURES PRIOR TO INITIAL USE. USE THE PRODUCT CORRECTLY AND WITH CARE FOR THE PURPOSE FOR WHICH IT IS INTENDED. FAILURE TO DO SO MAY CAUSE DAMAGE TO PROPERTY AND/OR SERIOUS PERSONAL INJURY. PLEASE KEEP THIS INSTRUCTION MANUAL SAFE FOR FUTURE USE.

1. SAFETY INSTRUCTIONS AND WARNINGS

- 1.1 **Inspect before each use.** Do not use if broken, bent, cracked, or otherwise damaged parts are noted. If any component of this product has been subject to a shock load (a load dropped suddenly or unexpectedly), discontinue use until it has been checked by a factory authorized service center.
- 1.2 The maximum ram capacity is 20 ton. **DO NOT** exceed this rated capacity.
- 1.3 When extension tubes are used, the rated capacity is always reduced by 50% for each tube connected.
- 1.4 **DO NOT** use this equipment as a vehicle lifting device or as a vehicle support.
- 1.5 Keep children and other unauthorized persons away from work area.
- 1.6 Remove loose clothing. Remove ties, watches, rings, and other jewelry, and contain long hair.
- 1.7 Always wear ANSI approved safety goggles when operating the repair kit.
- 1.8 Keep proper balance and footing. **DO NOT** overreach and wear nonslip footwear.
- 1.9 Only use this equipment on a surface that is stable, level, dry and not slippery. Ensure the surface can sustain the load. Keep the surface clean, tidy, and free from unrelated materials and ensure that there is adequate lighting.
- 1.10 **DO NOT** allow the piston rod of ram to extend so far as to exceed the maximum ram stroke.
- 1.11 When coupler valves are disconnected, always use dust cap to keep the hydraulic system clean.
- 1.12 **DO NOT** drop any heavy objects onto the hose and **DO NOT** twist the hose. Always keep the hose clean to avoid damage to the hose and couplers.
- 1.13 Keep the equipment away from heat or fire, as this may cause damage or weaken the seals.
- 1.14 **DO NOT** operate this equipment when you are tired or under the influence of alcohol, drugs, or any intoxicating medication.
- 1.15 **DO NOT** allow any untrained persons to operate the equipment and **DO NOT** make any modifications to it.
- 1.16 **DO NOT** expose the equipment to rain or any other kind of bad weather.
- 1.17 Use a qualified person to maintain the equipment in good condition. Keep it clean for best and safest performance.
- 1.18 If the equipment needs repairing and/or there are any parts that need to be replaced, have it repaired by authorized technicians and only use the replacement parts supplied by the manufacturer.
- 1.19 **WARNING:** The warnings, cautions, instructions discussed in the instruction manual cannot cover all possible conditions and situation may occur. It must be understood by the operator that common sense and caution are factors which can't be built in this product but must be supplied by the operator.

2. SPECIFICATIONS

Product No.	Ram Capacity (tons)	Pump Capacity (PSI)	Ram Closed Height (inch)	Extended Height		Effective Area		Net Weight (Lb)
				Ram extended Height (inch)	Extension Tubes Length (inch)	Dia. Of Inner Ram Cyl. (inch)	Effective Area (sq. in)	
030256	20	10,000	11.1	16	28.34 / 50 / 100.39 / 200 / 275.59	2.56	5.14	88.59

3. OPERATING INSTRUCTIONS

NOTE: Inspect before each use for evidence of fluid leaks, damaged hydraulic fittings, bent or broken attachments and missing parts.

- 3.1 Connect the hydraulic ram, hose, and pump unit together, ensure that you have securely fastened the couplers before pumping.
- 3.2 Firmly close the release valve by turning it clockwise.
- 3.3 Adjust the ram slowly to ensure the load is centered with the ram.

NOTE: The pump can be used in any position from horizontal to vertical. Always keep the hose end of the pump downward when it is not horizontal.

- 3.4 Pump the handle up and down to supply pressure. This will send fluid from the pump reservoir into the high-pressure hose assembly and into the ram assembly.
- 3.5 Continue pumping until the ram reaches desired position
- 3.6 To release pressure, **SLOWLY** and **CAREFULLY** turn the release valve counterclockwise (**never more than one full turn**) to release the pressure until ram retracts to desired position.

4. MAINTENANCE

- 4.1 When not in use, store the equipment in a dry location with the pump piston and the ram fully retracted.
- 4.2 Periodically check the ram and pump piston for signs of rust or corrosion. Clean exposed areas with a clean oiled cloth.

Warning: Never use sandpaper or abrasive material on any surfaces of the unit.

- 4.3 A coating of light lubricating oil to pivot points, axles and hinges will help to prevent rust and assure that pump assemblies move freely. Periodically lubricate the pivot points, axles and hinges with a light lubricating oil as needed.
- 4.4 With ram fully lowered, set pump unit in its normal, level position. Remove the oil filler screw to check the hydraulic oil level. If it is not adequate, add high quality hydraulic jack oil, as necessary.

Warning: DO NOT use brake fluid or any other improper fluid and avoid mixing different types of oil when adding hydraulic oil.

- 4.5 To ensure best performance and longer equipment life, replace the complete hydraulic oil at least once a year. With ram fully lowered, remove the oil filler screw.

Note: Dispose of hydraulic oil in accordance with local regulations.

- 4.6 When equipment efficiency drops, purge away air from hydraulic system: Turn the release valve counterclockwise by 1-1/2 turns, with ram fully retracted and release valve open, pump the handle rapidly for 10-20 times.
- 4.7 It is recommended that an annual inspection be done by qualified technicians.

5. TROUBLESHOOTING

Symptom	Possible Causes	Corrective Action
Ram will not lift load	<ul style="list-style-type: none"> 1. Release valve not tightly closed 2. Overload condition 3. Air trapped in system 	<ul style="list-style-type: none"> 1. Firmly close release valve 2. Remove the overload condition 3. Purge away air from system (see 4.6 for instructions)
Ram will not maintain load	<ul style="list-style-type: none"> 1. Release valve not tightly closed 2. Hydraulic unit malfunction 	<ul style="list-style-type: none"> 1. Firmly close release valve 2. Replace ram and/or pump
Ram will not lower after unloading	<ul style="list-style-type: none"> 1. Reservoir overfilled 2. Linkages binding 	<ul style="list-style-type: none"> 1. Drain oil to proper level 2. Clean and lubricate moving parts
Ram will not extend to full stroke	<ul style="list-style-type: none"> 1. Oil level low 	<ul style="list-style-type: none"> 1. Add hydraulic oil
Poor performance	<ul style="list-style-type: none"> 1. Oil level low 2. Air trapped in system 	<ul style="list-style-type: none"> 1. Add hydraulic oil to the system 2. Purge air from system (see 4.6 for instructions)

20T BODY REPAIR KIT SHD

PROD. NO. 030256
MOD. NO. BRK-20SHD

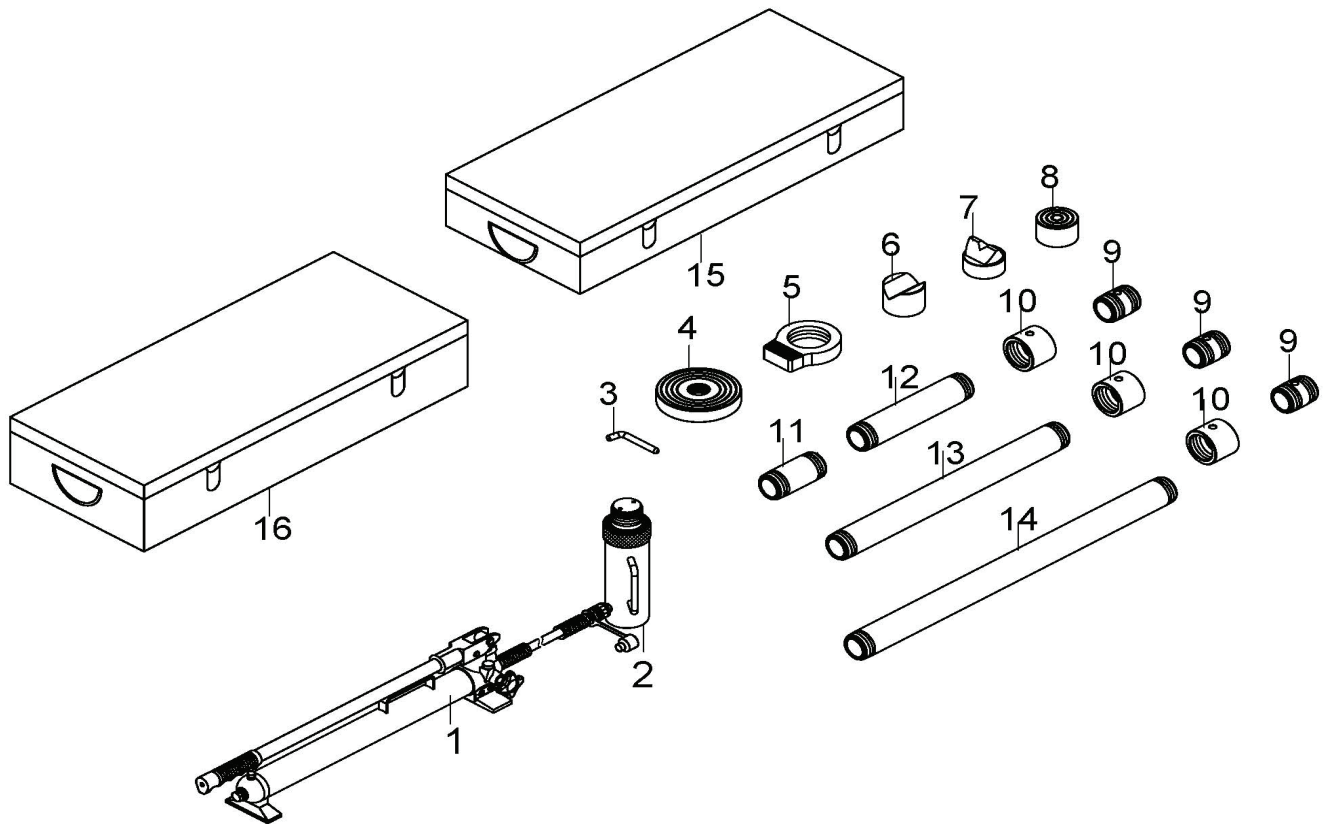

REF	PART NUMBER	DESCRIPTION	REQ	REF	PART NUMBER	DESCRIPTION	REQ
1	PCN-BRK20SHD-01	PUMP ASSY	1	9	PCN-BRK20SHD-09	EXTENSION TUBE 1	1
2	PCN-BRK20SHD-02	RAM ASSY	1	10	PCN-BRK20SHD-10	CONNECTION TUBE	1
3	PCN-BRK20SHD-03	PIN	1	11	PCN-BRK-20SHD-11	EXTENSION TUBE 2	1
4	PCN-BRK20SHD-04	BASE	1	12	PCN-BRK20SHD-12	EXTENSION TUBE 3	1
5	PCN-BRK20SHD-05	RAM TOE	1	13	PCN-BRK20SHD-13	EXTENSION TUBE 4	1
6	PCN-BRK20SHD-06	V-BASE	1	14	PCN-BRK20SHD-14	EXTENSION TUBE 5	1
7	PCN-BRK20SHD-07	WEDGE TOE	1	15	PCN-BRK20SHD-15	STEEL BOX 2	1
8	PCN-BRK20SHD-08	PLUNGER TOE	1	16	PCN-BRK20SHD-16	STEEL BOX 1	1

20T BODY REPAIR KIT SHD

PROD. NO. **030256**
MOD. NO. **BRK-20SHD**

PUMP REPAIR KIT

PCN-BRK20SHD-PRK

P2,P4,P6,P9,P10,P12,P13,P14,P15

P16,P17,P18,P19,P20,P21,P23,P25

P26,P27,P28,P29,P30,P31

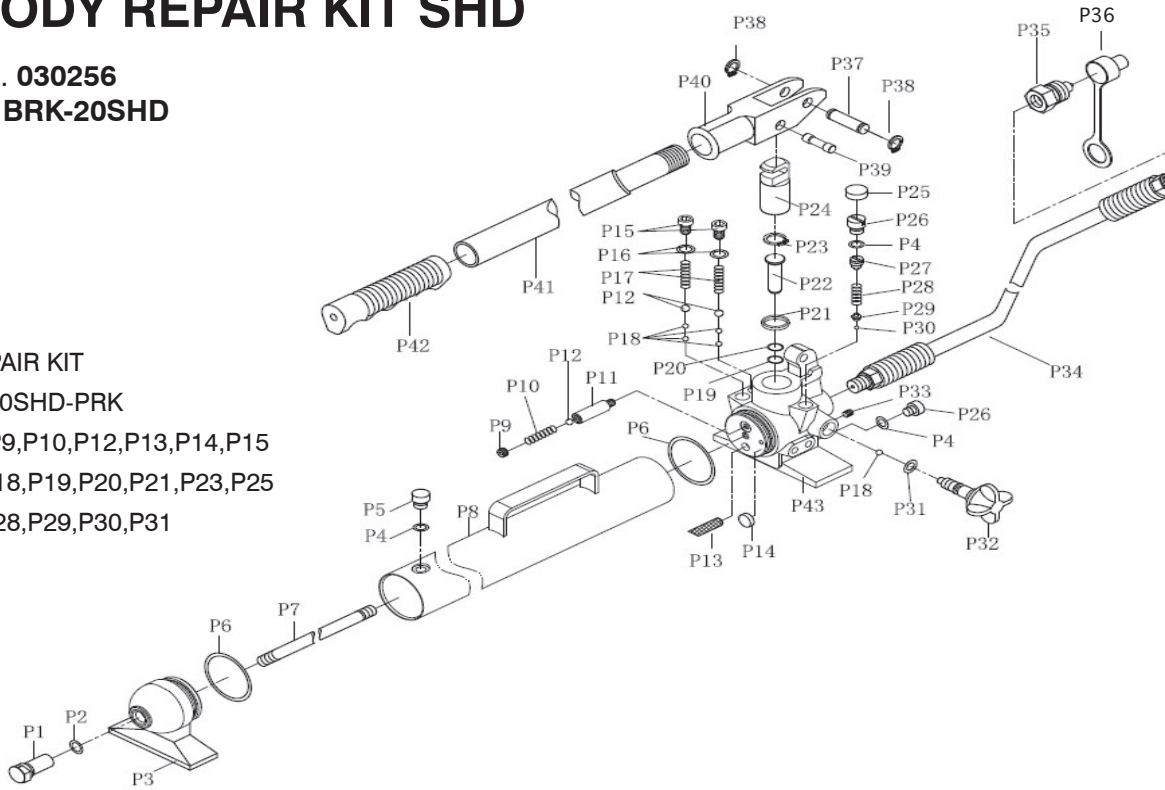

REF	PART NUMBER	DESCRIPTION	REQ	REF	PART NUMBER	DESCRIPTION	REQ
P1	PCN-BRK20SHD-P1	SCREW	1	P22	PCN-BRK20SHD-P22	SMALL PISTON	1
P2	PCN-BRK20SHD-P2	O-RING	1	P23	PCN-BRK20SHD-P23	RETAINER RING	1
P3	PCN-BRK20SHD-P3	CAP	1	P24	PCN-BRK20SHD-P24	BIG PISTON	1
P4	PCN-BRK20SHD-P4	O-RING	3	P25	PCN-BRK20SHD-P25	CAP	1
P5	PCN-BRK20SHD-P5	SCREW	1	P26	PCN-BRK20SHD-P26	SCREW	2
P6	PCN-BRK20SHD-P6	O-RING	2	P27	PCN-BRK20SHD-P27	SCREW	1
P7	PCN-BRK20SHD-P7	PULLING ROD	1	P28	PCN-BRK20SHD-P28	SPRING	1
P8	PCN-BRK-20SHD-P8	OIL TANK	1	P29	PCN-BRK20SHD-P29	STEEL BALL SEAT	1
P9	PCN-BRK-20SHD-P9	SCREW	1	P30	PCN-BRK20SHD-P30	STEEL BALL	1
P10	PCN-BRK20SHD-P10	SPRING	1	P31	PCN-BRK20SHD-P31	O-RING	1
P11	PCN-BRK20SHD-P11	SPRING SEAT	1	P32	PCN-BRK20SHD-P32	REL VALVE KNOB	1
P12	PCN-BRK20SHD-P12	STEEL BALL	3	P33	PCN-BRK20SHD-P33	SCREW	1
P13	PCN-BRK20SHD-P13	FILTER	1	P34	PCN-BRK20SHD-P34	HOSE	1
P14	PCN-BRK20SHD-P14	STEEL	1	P35	PCN-BRK20SHD-P35	MALE FITTING	1
P15	PCN-BRK20SHD-P15	SCREW	2	P36	PCN-BRK20SHD-P36	DUST CAP	1
P16	PCN-BRK20SHD-P16	COPPER WASHER	2	P37	PCN-BRK20SHD-P37	PIN	1
P17	PCN-BRK20SHD-P17	SPRING	2	P38	PCN-BRK20SHD-P38	RETAINER RING	2
P18	PCN-BRK20SHD-P18	STEEL BALL	5	P39	PCN-BRK20SHD-P39	PIN	1
P19	PCN-BRK20SHD-P19	O-RING	1	P40	PCN-BRK20SHD-P40	HANDLE SOCKET	1
P20	PCN-BRK20SHD-P20	WASHER	1	P41	PCN-BRK20SHD-P41	HANDLE TUBE	1
P21	PCN-BRK20SHD-P21	U-RING	1	P42	PCN-BRK20SHD-P42	HANDLE COVER	1
				P43	PCN-BRK20SHD-P43	PUMP HOUSING	1

20T BODY REPAIR KIT SHD

PROD. NO. 030256
MOD. NO. BRK-20SHD

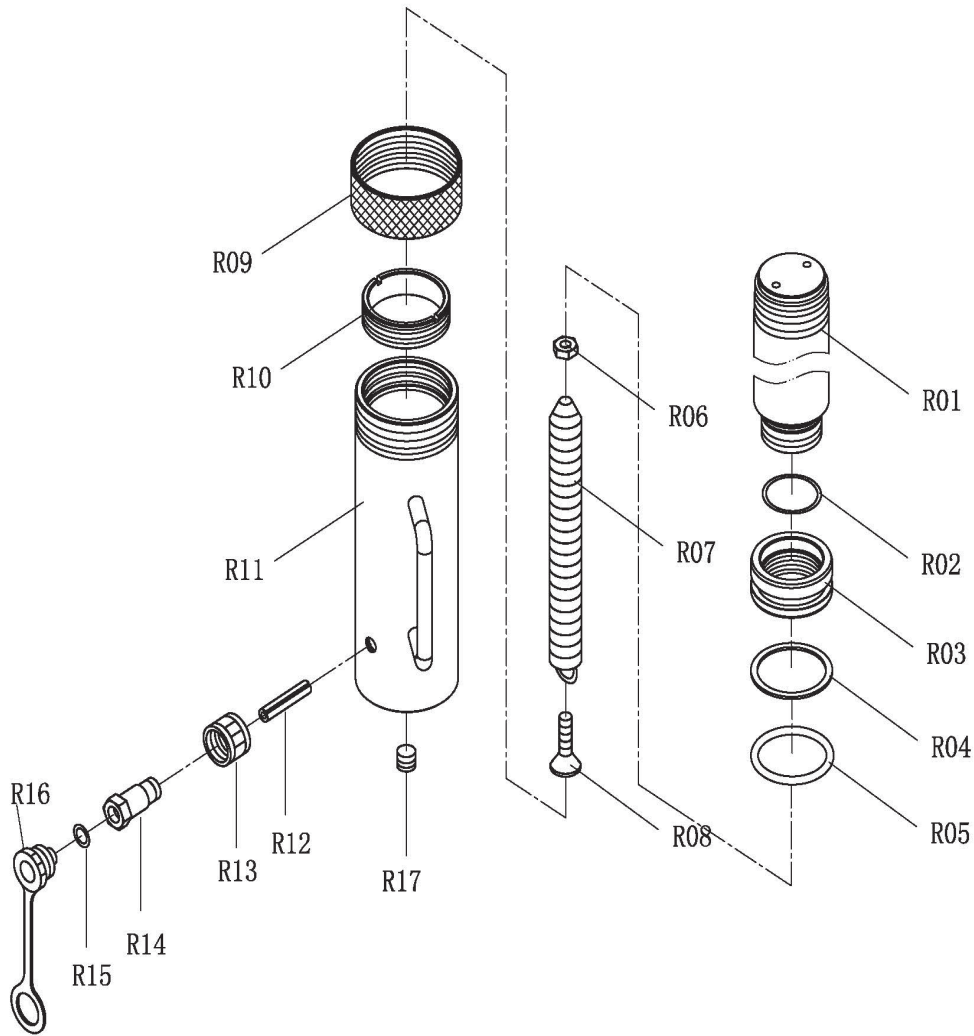

REF	PART NUMBER	DESCRIPTION	REQ	REF	PART NUMBER	DESCRIPTION	REQ
R01	PCN-BRK20SHD-R01	PISTON ROD	1	R10	PCN-BRK20SHD-R10	LIMITED RING	1
R02	PCN-BRK20SHD-R02	O-RING	1	R11	PCN-BRK20SHD-R11	RAM	1
R03	PCN-BRK20SHD-R03	PISTON	1	R12	PCN-BRK20SHD-R12	PIN	1
R04	PCN-BRK20SHD-R04	WASHER	1	R13	PCN-BRK20SHD-R14A	CONNECTOR ASSY	1
R05	PCN-BRK20SHD-R05	O-RING	1	R14	PCN-BRK20SHD-R14A	CONNECTOR ASSY	1
R06	PCN-BRK20SHD-R06	NUT	1	R15	PCN-BRK20SHD-R14A	CONNECTOR ASSY	1
R07	PCN-BRK20SHD-R07	SPRING	1	R16	PCN-BRK20SHD-R14A	CONNECTOR ASSY	1
R08	PCN-BRK20SHD-R08	SCREW	1	R17	PCN-BRK-20SHD-R17	SCREW	1
R09	PCN-BRK20SHD-R09	RAM COVER	1				

