

# BET skruv P

# Adjufix

The Original System Solution

## BETONG & MASSIVTEGEL SKRUV MED PLUGG

Betong & massivtegel skruv med plugg.  
För montering av fönster och dörrkarm.

08-2021

**Säkerhetsfaktor: 4**



### Användning

### Bärförmåga

För betongklass C20/C25

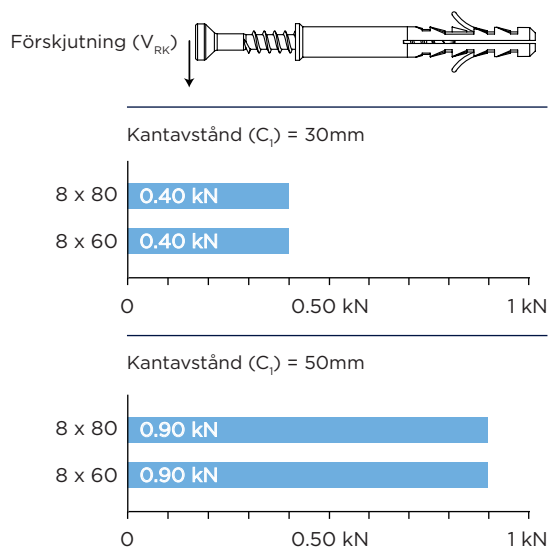
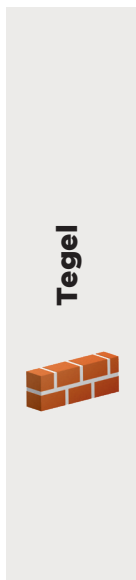
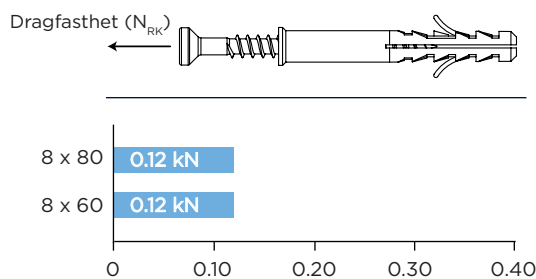
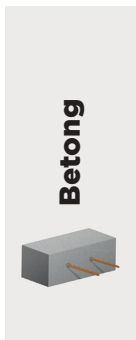

### Monteringsanvisning

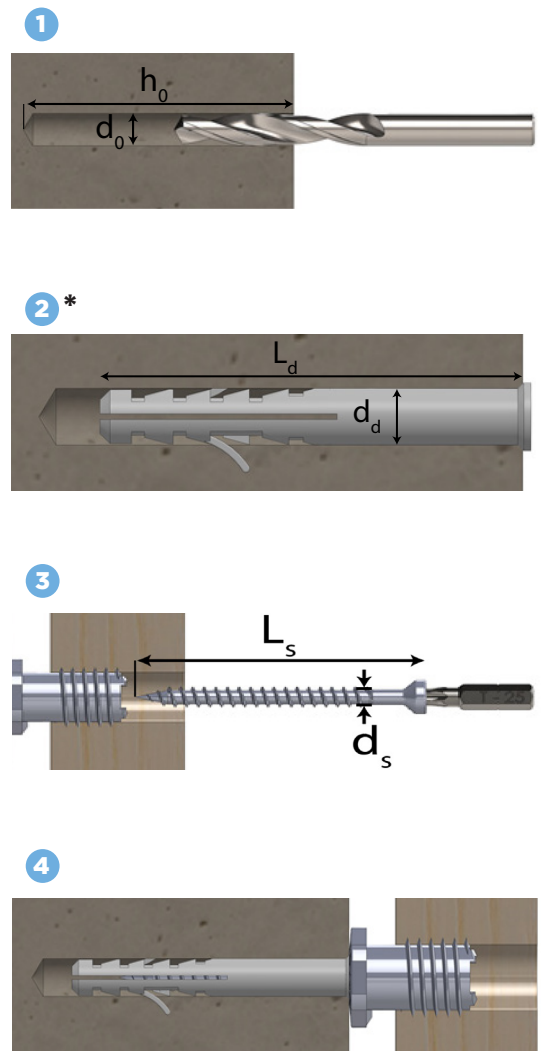

Hylsdimension [mm]	Borrdjup [mm]	Borrdiameter [mm]	Minimum kantavstånd [mm]	Utdragsvärde [kN]	Förskjutningskraft $c_1=30\text{mm}$ [kN]	Förskjutningskraft $c_1=50\text{mm}$ [kN]	Skruvdimensioner [mm]	ITW nr.
$d_d \times L_d$	$h_0$	$d_0$	$c_1$	$N_{RK}$	$V_{RK}$	$V_{RK}$	$d_s \times L_s$	
8 x 60	65	8	30	0.12	0.40	0.90	6 x 65	120109
8 x 80	85	8	30	0.12	0.40	0.90	6 x 88	120111

\* Se till att noga rengöra det borrarade hålet innan hylsan monteras