

PROTAN Steel Bar

No. 39000025

Application area:

In exposed roof systems Protan requires the membrane at the transition between the roof surface and the parapet to be fastened linearly. Protan Steel Bar provides a good air seal and linear retention, as well as reducing the risk of point loading at the welds and fastenings. The strength and rigidity of the bar ensures that horizontal and vertical forces in the roofing are transferred to it as an evenly distributed load.

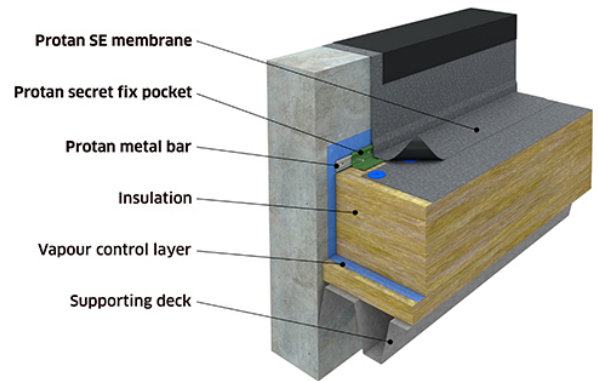

Protan provides different standardised parapet systems.

Specification:

Protan Steel Bar is 1,5mm thick cold formed, Zink coated steel and complies with European standard EN 10346 : 2009

Protan steel bar has 20 mm diameter pre-drilled holes every 75 mm for insertion of fasteners in sleeves and between the 20 mm holes there are two 6,5 mm pre-drilled holes at a distance of 25 mm apart for screws without plastic selves.

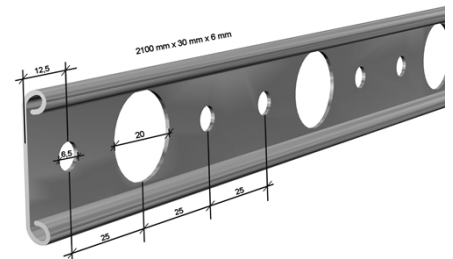

Mechanical properties:

Essential characteristics		Performance	
Rm	Min-Max	270-550 N/mm ²	EN10346:2009
A80 ₁	Min	22 %	EN10346:2009
Thickness	Max	0,12 mm	EN10143:2006

The values shown for the mechanical properties in table below are for test pieces taken transverse to the rolling direction.

1. For thicknesses >0.5mm and ≤0.7mm (including coating), the minimum elongation after fracture is decreased by 2 units. For thicknesses ≤0.5mm, the reduction is 4 units.

Chemical composition:

Protan Steel Bar meets the requirements of the cast analysis according to EN10346:2009 shown in table below.

C	SI	Mn	P	S	Ti
Max	Max	Max	Max	Max	Max
0,12	0,50	0,60	0,10	0,045	0,30

All values are in weight percentage