

# INSTALLATION INSTRUCTION

2018:1

## Purusline Living Wetroom Solution 800 Tile Insert Grate

### Planning Information and Installation Instructions

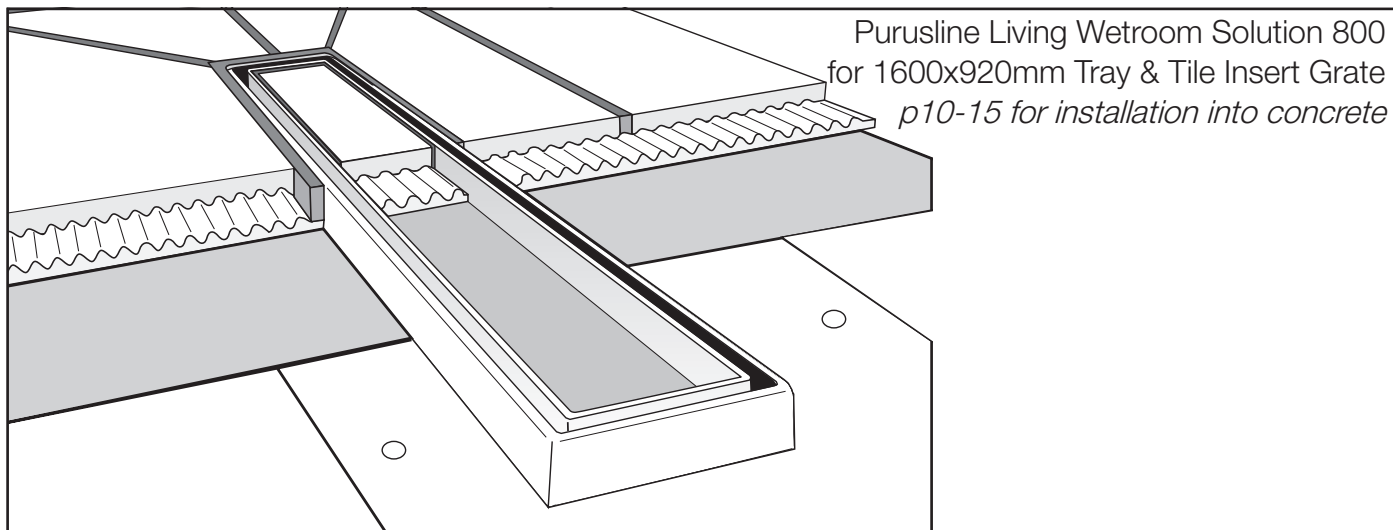
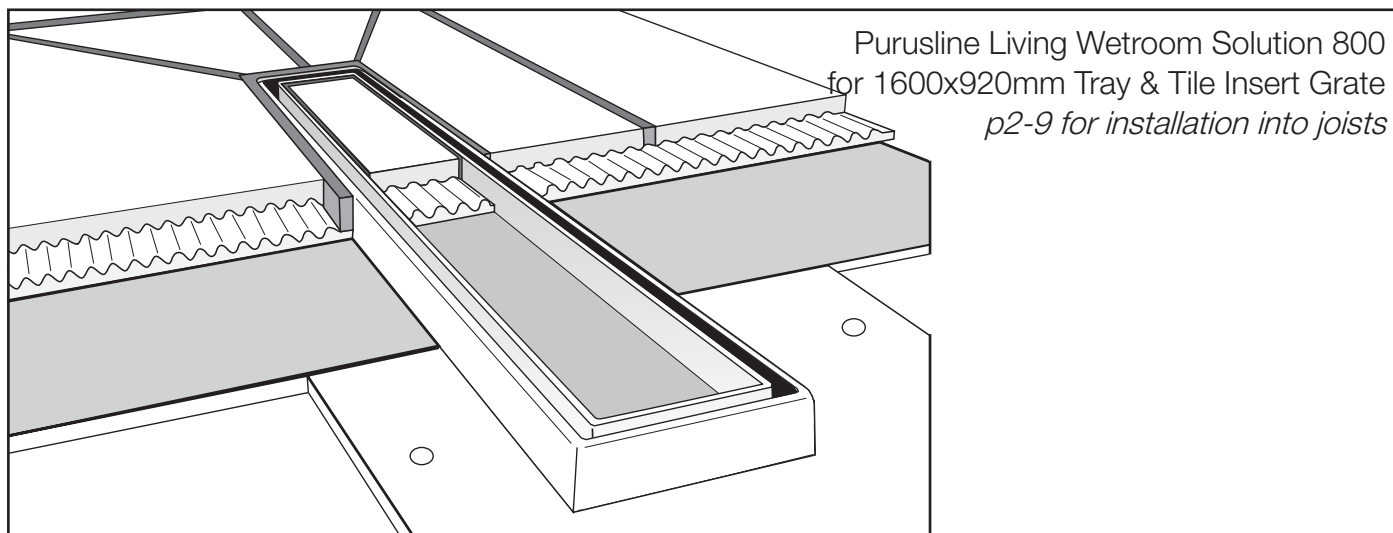

Our ongoing product development may lead to changes in execution, design and construction, for which we accept no liability.

02830

# PURUS

# Purusline Living

## Wetroom Solution 800

### Installation instructions for wooden floorboards

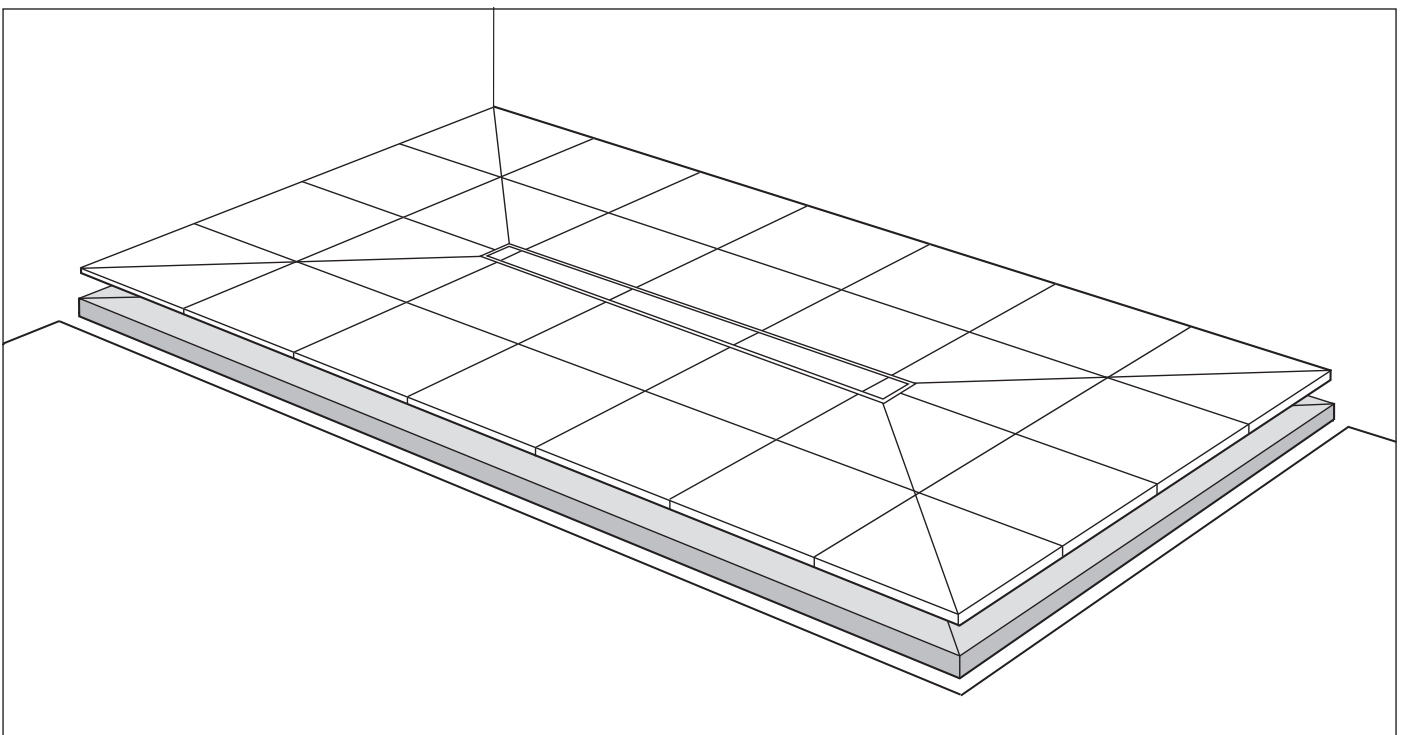
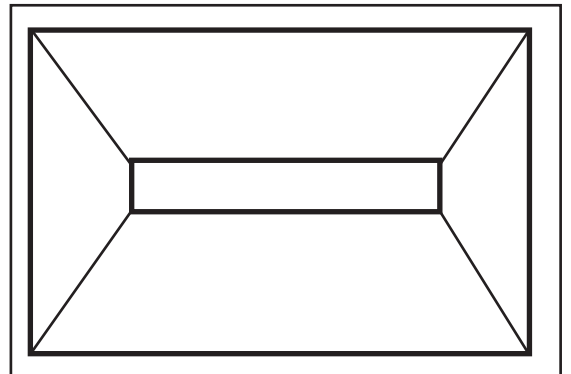
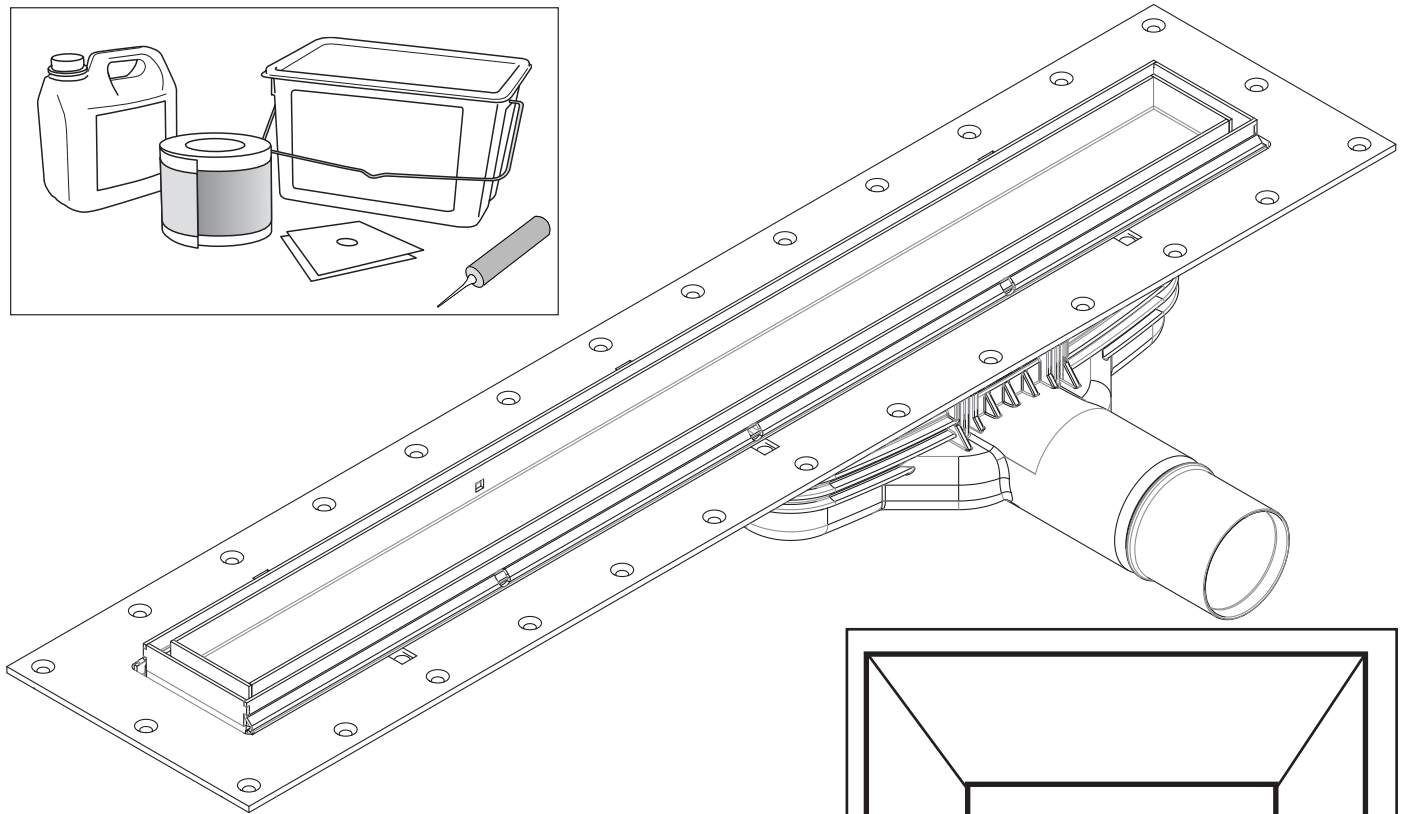
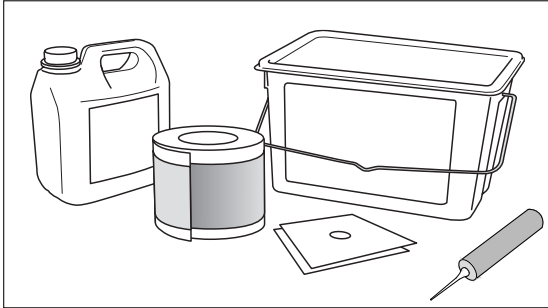

## Important

Read all the pages of these instructions fully and thoroughly before you commence installing and keep in a safe location for future reference.

Always watch the installation video as an aid to installation prior to installing. [www.purusgroup.com](http://www.purusgroup.com)

## Plumbing

All plumbing work should be carried out by a fully qualified professional plumber. 1½ inch ABS pipe adapter/connector provided.

## CHECK LIST/SAFETY NOTES

- **If there is any movement or flexing whatsoever on the joists or floorboards, then they need to be made good and solid according to BS5268, and to BS6178 if using joist hangers, before installing. To make good, you must add structural supports and/or braces to the joists and/or floorboards. If there is still movement, do not fit the product.**
- **Do not install the product on a raised platform. It is designed only to be installed level with the surrounding floor.**
- The tray can be cut to size by using a saw if required, ensuring you take extra care so as not to break the tray. Please ensure that you do not cut within 200mm of the outlet hole. Please note that cutting the tray will decrease the thickness of the tray at the edges, so try to put the cut edges against the wall. Also you will have to consider the finished look of the tiles when changing the tray's size.
- Ensure you have all the contents supplied before installation. If you do not have all the contents do not install. Contact your supplier straight away.
- Check all the contents for damage. If any parts are damaged do not install. Contact your supplier straight away.
- Check the level of the floorboards prior to installation of the tray and tile backer board. If they are +or- 5mm this is acceptable. If they are over these tolerances, once the floor has been made sound and secure, use an appropriate levelling compound or tile adhesive to level the floor in accordance with BS5385. If this is not possible, do not install.
- The grate when installed must be horizontal and flat. It also must be level with the tile surface and not at an angle or on a slope.
- Check where all pipes, electrical cables and all other services are prior to drilling, cutting and screwing into walls, ceilings and floors.
- Use dry wall screws to fix the tray to the floorboards. When screwing avoid any pipes, electrical cables and all other services.
- Ensure your tools for installation are fit for purpose and follow manufacturer's instructions provided with the tools.
- Do not use power tools on the screws of the gully.
- The maximum height for the tile insert grate is 12mm. Combined tile and adhesive should not exceed 12mm. It is recommended that a maximum of 10mm porcelain tile is used.
- If you have tile, adhesive and/or underfloor heating exceeding the 12mm height then you will need the Stainless Steel Grate Solution 800 which has a maximum height level of 26mm.
- Remove any skirting boards in the room.
- Any gaps or holes/damage in the walls and floors must be made good. We recommend using appropriate tile backer boards to level the room out following BS5385 for tiles.
- Do not put any primer on the tray. It is a good tip to prime your walls/plasterboard before you install the tray with Puragum Primer from the tanking kit.
- Use C2 tile adhesive and C2 grout, always checking the manufacturers' minimum drying times for wetrooms.

- Always ensure the installation and working areas are kept safe, especially from children and pets.
- Work safely; ensure that no tools are lying around and that the working and installation areas are clean and tidy at all times.
- Ensure that all sharp devices such as knives and saws have covers on them at all times. Do not carry knives in pockets.
- Safety goggles, masks and gloves should be worn at all times.
- The Puragum Tanking Kit covers 7-8m<sup>2</sup>. Ensure you have enough to cover all of the floor and walls.
- Check the litres per minute output of your shower/showers before choosing the waste outlet especially if you are going to use a shower pump. The flow rate for the gully is 60 litres per minute for the Side and Side Side waste outlets, and 30 litres per minute for the Low waste outlet. Do not exceed these limits unless using multiple gullies.

## Underfloor heating

If your underfloor heating is an electrical system, ask the manufacturer if the electric underfloor heating mat is suitable for a wetroom and if the temperature can be controlled by a thermostat, if not, do not use. Always follow the Underfloor Heating Manufacturer's Instructions of how to install the system.

The underfloor heating system must be fully buried into concrete/screed/tile adhesive/levelling compound before the tanking is applied. Please refer to the Underfloor Heating and Tile Adhesive/Grout manufacturers' instructions for guidance or contact the supplier's technical help line before installing.

From the bottom upwards you should fix in this order: the floor surface; underfloor heating mat fully embedded into screed/concrete/suitable levelling compound; wetroom tanking, tile adhesive, tiles, tile grout.

When the Tanking System, The Tile Adhesive and Tile Grout is fully cured for a wetroom (always check the Tile Adhesive and Tile Grout manufacturers' drying out times for a wetroom), then turn on the Thermostat according to the manufacturer's instructions only by 3°C a day to a maximum of 30°C. This will take 10 days in the first instance. After that you can select your ambient temperature. Never go over 30°C.

## Packaging

Once packaging has been unpacked and used it should always be taken to the nearest local authority waste collection site for recycling. The packaging must not be thrown away with normal household waste.

## Liability

The Manufacturer will not accept any liability for failure if the Purusline Living Wetroom Solution has been installed incorrectly and with disregard to the instructions.

**It is extremely important when installing a wet room that you fully seal/tank the room. Take your time. The tanking of the room is the most important part. Check all tapes and gaskets are secure and bonded before tiling.**

**It is also extremely important to follow the manufacturer's instructions for the drying time for the C2 tile adhesive and grout when being used for a wetroom. It will be significantly longer than for tiles in a shower tray situation.**

**After the drying period, ensure that you test your room after tiling to ensure the room is fully watertight. Do not use the wet room/shower room until tests are thoroughly completed. The completed wetroom must be left to dry to the minimum stated in the manufacturer's instructions for the adhesive and grout for a wetroom. It may be beneficial to use an epoxy resin grout as it will cure quicker and offer better water resistance.**

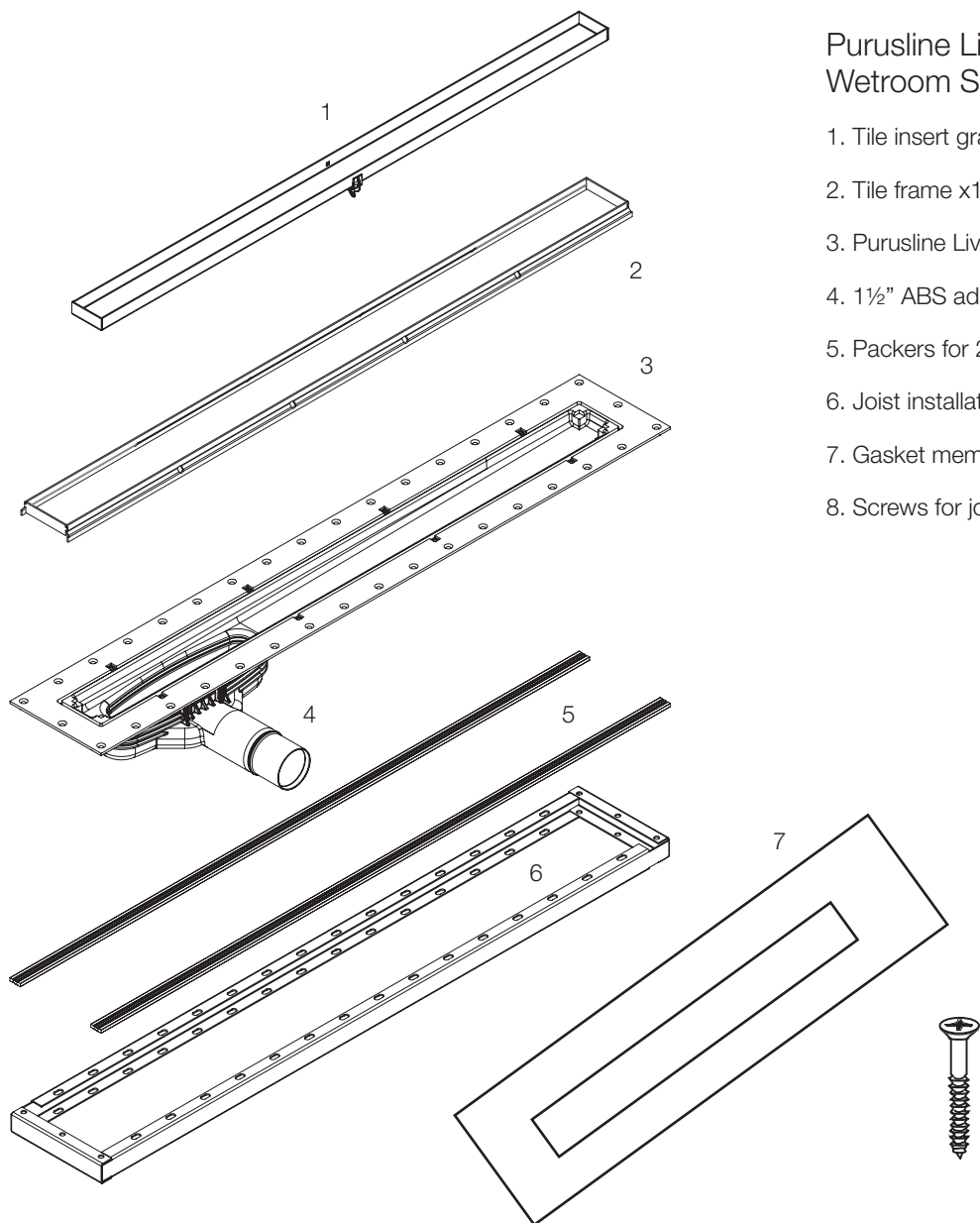

Purusline Living Linear  
Wetroom Solution

- 1. Tile insert grate x1
- 2. Tile frame x1
- 3. Purusline Living gully x1
- 4. 1½" ABS adapter for solvent weld x1
- 5. Packers for 22mm floors x2
- 6. Joist installation rails x2
- 7. Gasket membrane x1
- 8. Screws for joist installation x12

Wetroom Tray (for the 800 gully only)  
1600mm x 920mm x 18mm

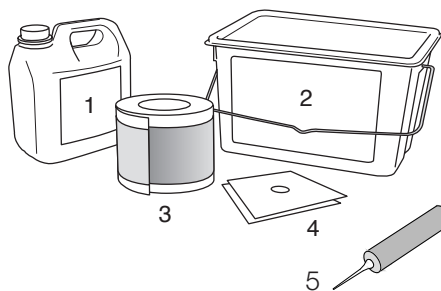
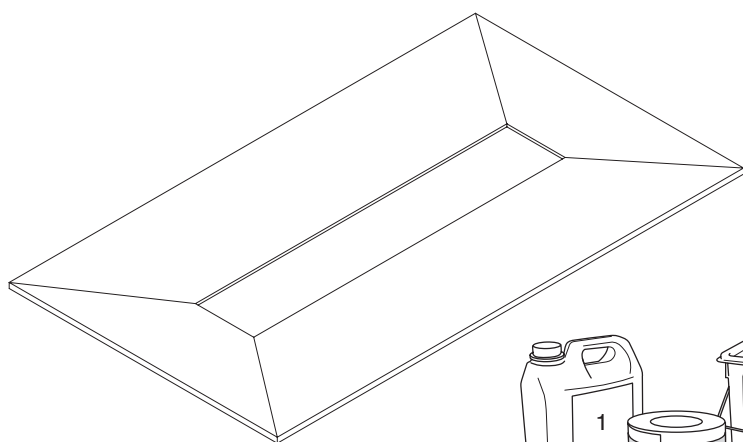

Wetroom  
Tanking Kit

- 1. Primer
- 2. Puragum
- 3. Pura Elastomeric  
Tapes
- 4. Pura Pipe Covers x2
- 5. MS Polymer

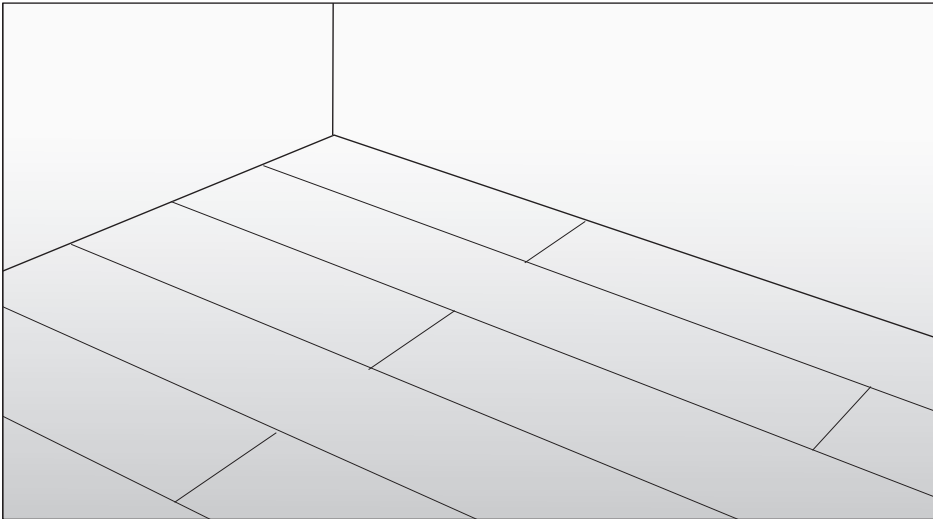

If there is any movement or flexing whatsoever on the joists or floorboards, then they need to be made good and solid according to BS5268, and to BS6178 if using joist hangers, before installing.

To make good, you must add structural supports and/or braces to the joists and/or floorboards according to BS5268, and to BS6178 if using joist hangers. If there is still movement, do not fit the product.

Stage 1

Ensure the walls and floor are free from dirt and protruding nails and objects and that the floor coverings have been removed. Remove all skirting and make good any damage/gaps.

Using a spirit level check that the floor is level. Plus or minus 5mm per metre is acceptable.

Stage 2

Once the floor is level, lay out the tray into position on the floor.

The tray can be cut to size by using a saw if required, ensuring you take extra care so as not to break the tray. Please ensure that you do not cut within 200mm of the outlet hole. Please note that cutting the tray will decrease the thickness of the tray at the edges, so try to put the cut edges against the wall. Also you will have to consider the finished look of the tiles when changing the tray's size.

Using a marker pen, mark out the 133mm wide x 830mm long area in the centre of the tray onto the floor.

Remove the tray and put to one side. Add 3mm to all sides making the cut 836mm long x 139mm.

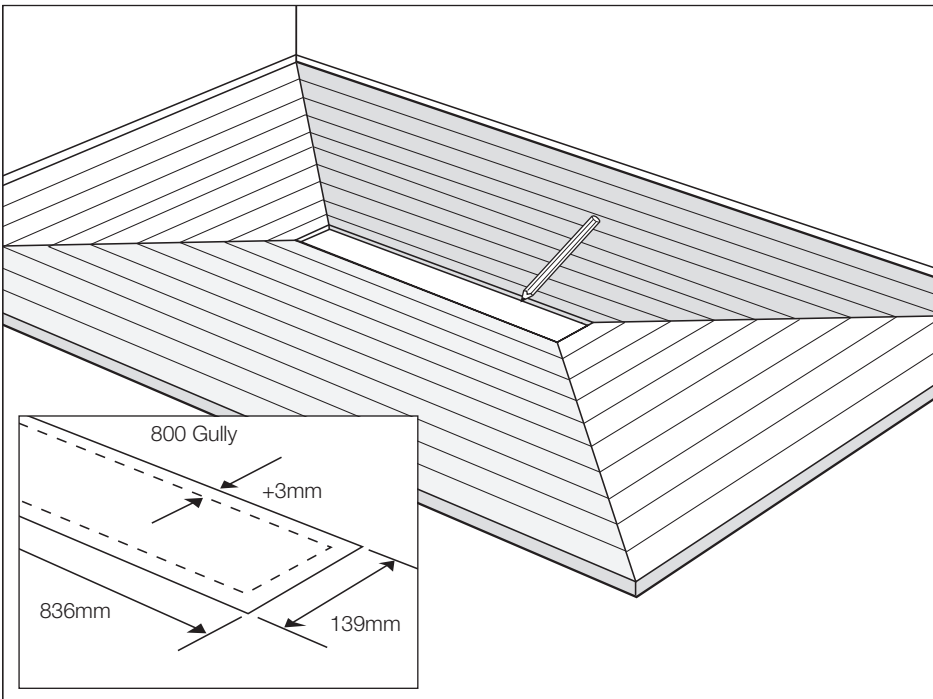

Remember if you need to prime the walls, this is a good time to do it as you must not put primer on the tray.

Stage 3

Using a circular saw, with a cutting depth set to the depth of the floorboards, cut out a rectangular shape on the floor (139mm x 836mm), making sure you are cutting to the inside of the drawn line.

Noggins need to be installed to support the joist installation rails. Using 4" x 2" timbers, create a support for the whole perimeter of the product. Ensure there is no movement. Please make sure both ends of the channel are supported underneath and screwed down.

Then cut another hole in line with the waste pipe to the gully outlet. Keep the piece from this hole as you will need it to make good after the gully outlet is connected.

Ensure that the saw does not cut into the joists.

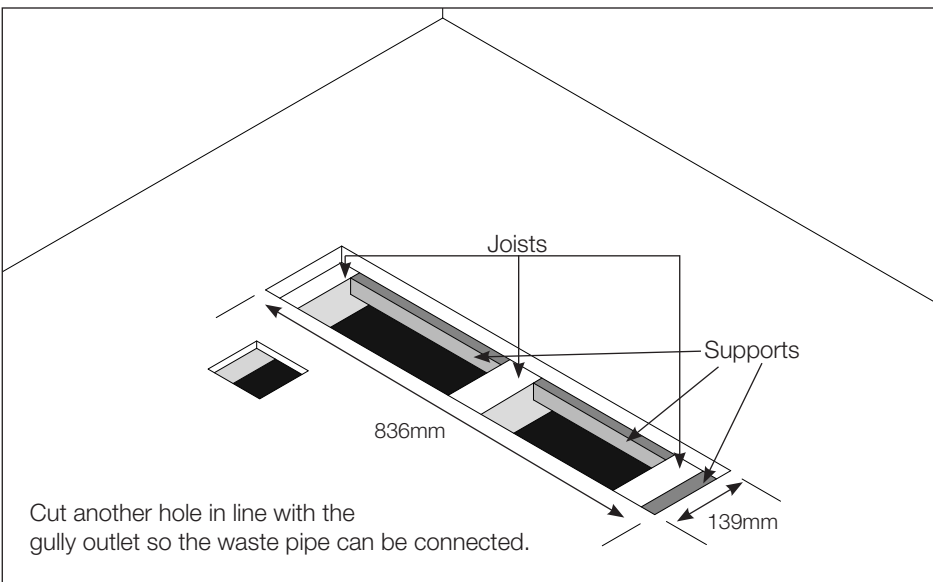

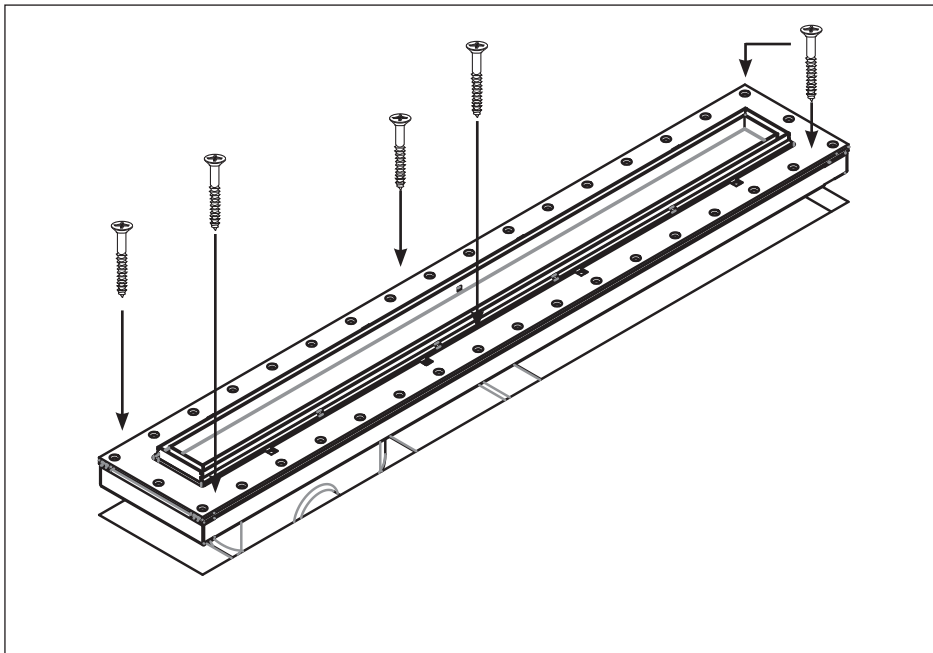

Stage 4

Place the gully and joist installation rails in position and check it is level and 10mm above the floor.

Once level, place the installation rails into position. Screw and fix into the joists using the screws supplied. If you have 22mm floorboards you will need the packers for 22mm floorboards and/or end supports. Place these on the joists before screwing and fixing the gully and rails into the joists.

**Do not use power tools.**

Waste pipes

If your waste pipe is an ABS plastic 1½ inch or 42.9mm pipe then you can use the supplied 42.9mm (1½ inch) ABS pipe adapter provided for solvent welding and connecting to the 42.9mm (1½ inch) waste pipe.

The push fit end must be fully inserted into the gully prior to connecting to the waste pipe. The gully and adapter can then be solvent welded to the waste pipe by a fully qualified professional plumber. If the waste pipe is not an ABS plastic 1½ inch or 42.9mm pipe then a mechanical fixing connector must be used to connect the gully outlet to the waste pipe by a fully qualified professional plumber. The pipe must be clipped to the joist as close to the outlet gully as possible, as per the NHBC Technical Guidelines for plastic pipework. Once the gully has been connected to the waste pipe and tested for leaks by your fully qualified plumber, the hole cut for connecting the pipe should be made good.

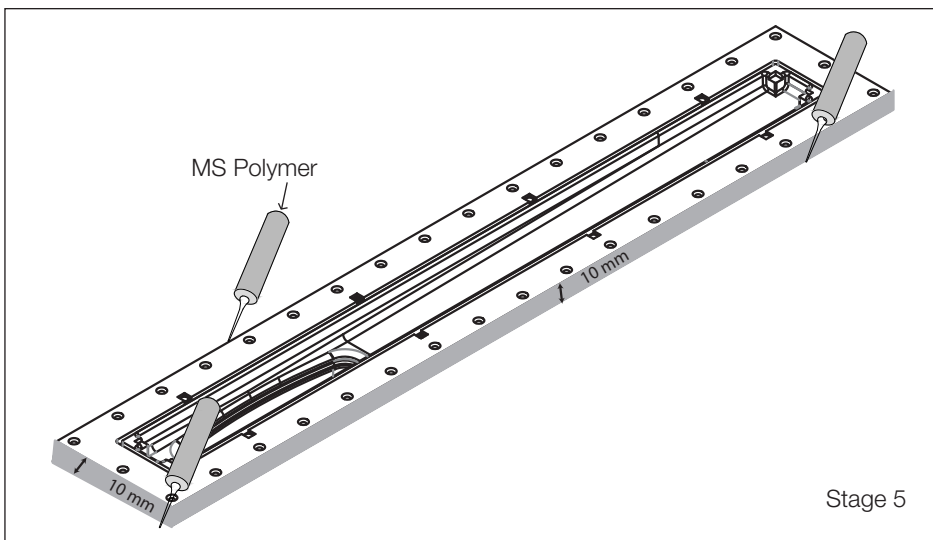

Stage 5

If you have existing walls covered with plaster or plasterboard use Puragum Primer to seal the walls. If the walls are not covered, then clad walls with panels or plaster board (not supplied) and coat with Puragum Primer (follow the instructions provided in the tanking kit).

**IMPORTANT: Always ensure you do not apply Puragum Primer to the tray.**

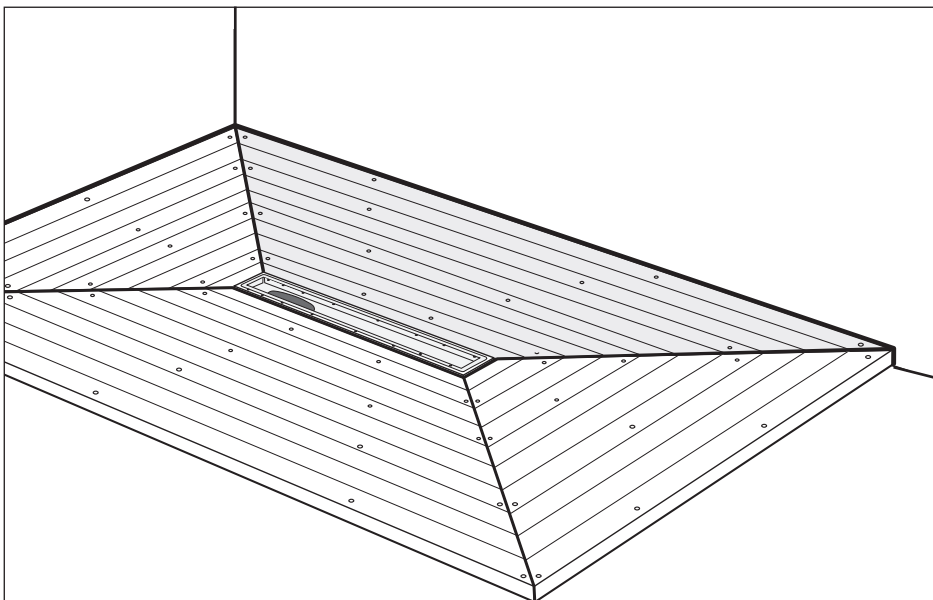

Stage 5

Use the MS Polymer to seal the gap between the floor and the installation rail all the way round. Whilst the MS Polymer is still wet, lay the tray into position. Screw the tray down to the floorboards at 150mm (6inch) centres.

Use dry wall screws (not supplied).



**IMPORTANT:** Ensure you avoid screwing through any pipework, cables or services etc.

Follow this step until you have fitted the whole tray.

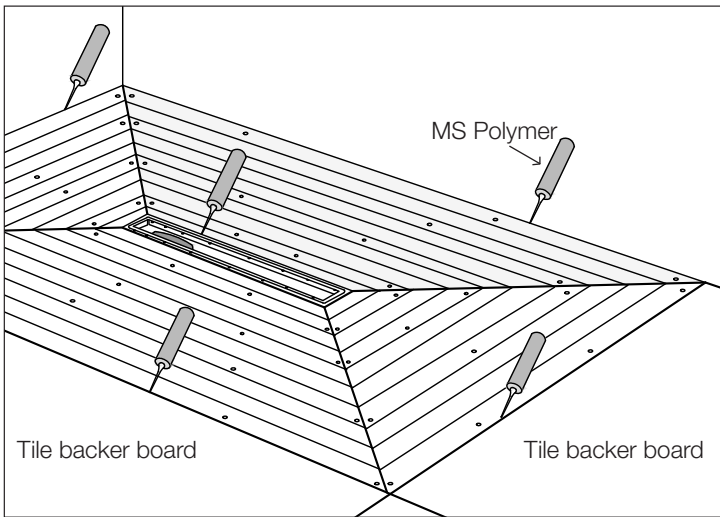

**Stage 6**

Level the floor with appropriate tile backer boards. Fix the tile backer boards to the floorboards in accordance to BS5385 for ceramic tiles and following the manufacturer's installation instructions, using screws and washers where required. Seal all tile backer board joints on the floor, as well as the joints between the tile backer board and tray, with MS Polymer and then tapes.

Then totally fill the following gaps with the MS Polymer, smoothing down as you go along and ensuring that all the gaps are fully sealed:

- 1). between the gully and the tray;
- 2). between the tray and walls;
- 3). between the tray and floor;
- 4). between the tile backer board joints.

Check the gully is fixed securely.

Take the Pura Elastomeric Tapes and dry cut to the tray, floor, walls and board joints.

Once the MS Polymer has tacked over, using a brush or roller apply the Puragum to all wall, floor and tray joints one at a time. Apply the Pura Elastomeric Tapes while the Puragum is still wet, firmly smoothing down the tape as you go so there are no air pockets or ridges left and the tapes are fully adhered.

Now allow to dry for 3 hours.

Ensure all tile backer board joints are fully sealed with waterproof tapes suitable for tile backer boards.

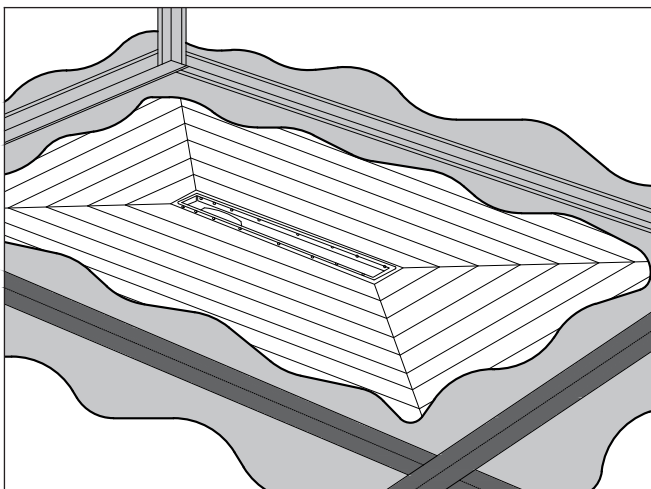

**Stage 7**

Now fix the gasket into position with MS Polymer. First check if it fits properly then place the gasket into position making sure it is centred and mark the outer and inner perimeters onto the surface below. Remove the gasket. With the MS Polymer, create a zigzag pattern in the marked area and then with a clean flat scraper, smooth the MS Polymer in the entire marked area to a thickness of 1mm to 1½mm and only overlapping the marked lines by 1-2mm. By doing this you will ensure the whole gasket is fixed. Immediately fix the gasket into position whilst the MS Polymer is still wet and not tacked over. Making sure you are pressing with reasonable amounts of pressure, push out all the creases and air bubbles beneath the gasket. Go over the whole gasket with a clean wide flat scraper pushing it into the MS Polymer. Check there is full adhesion and ensure it is completely fixed.

Now allow to dry for 3 hours.

The Puragum Tanking Kit covers 7-8m<sup>2</sup>. Ensure you have enough to cover all of the floor and walls.

**Stage 8**

Now cover the whole tray, tapes, gasket, walls and floor with one coat of Puragum and allow to dry for another 3 hours, then apply a second coat. Ensure the Puragum goes up the sides of the tile insert grate ensuring you overlap the gasket with the two coats of Puragum (when applying the Puragum ensure the weep holes are kept intact), then leave to dry for a minimum of 24 hours before tiling depending on site conditions.

**Once the second coat of Puragum has fully cured, check the tapes and gasket are fully secure and sealed before tiling.**

Ensure the tanking kit is installed as per the instructions. Ensure you follow the tanking kit instructions and that the tapes and membranes are fully secure before tiling.

**Ensure you keep to the minimum drying times. Drying times could be longer depending on site conditions.**

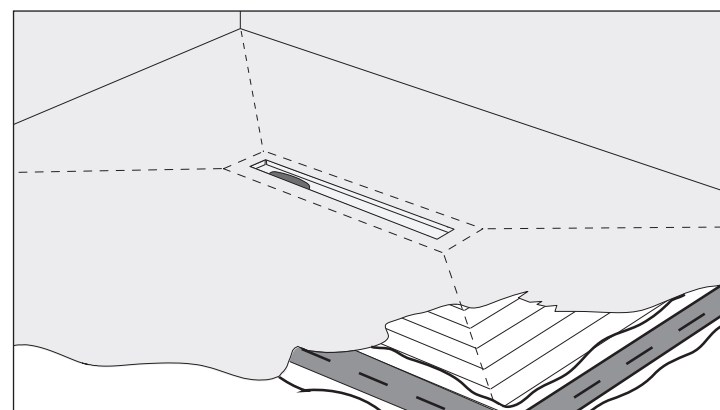
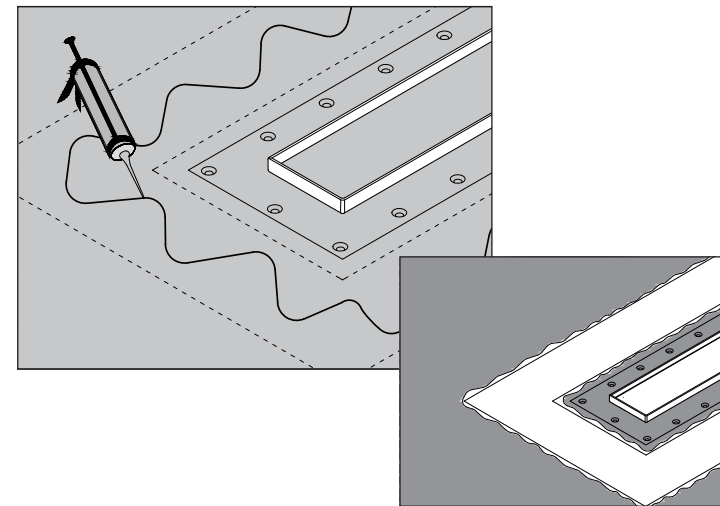

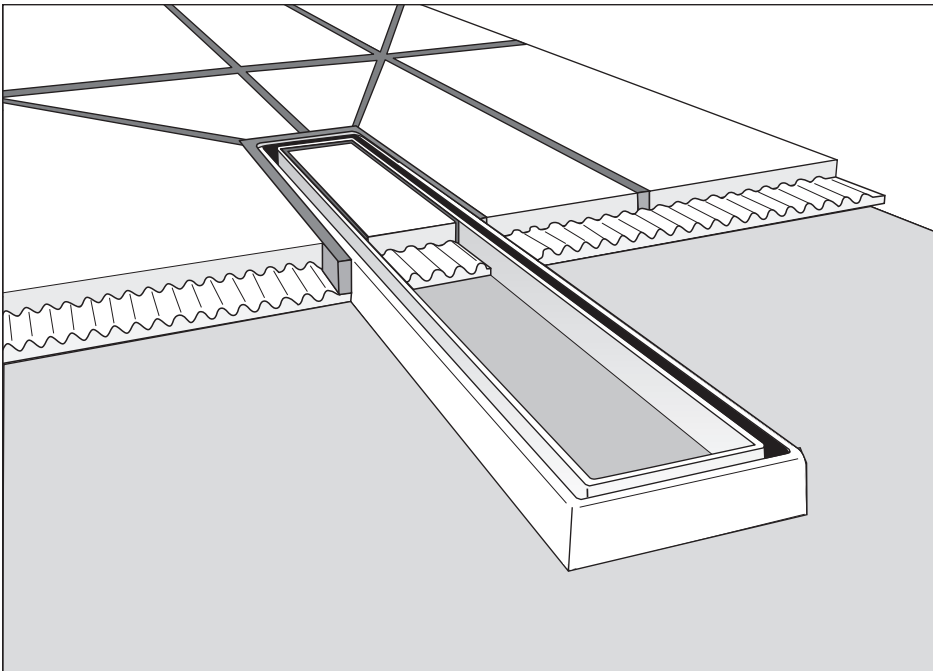

Stage 9

Tile the tray to the desired pattern, followed by the insert cover using EN12004 C2 classified tile adhesive applied using a notched trowel in accordance with the code of practice BS5385.

Fix the tiles with adhesive that fastens to stainless steel.

Use a small straight edge up against the gully gap so as to prevent the tile adhesive falling into the gully body.

Finally grout the gaps with flexible, water proof, anti-mould grout, ensuring that no grout falls into the gully body. **Allow to dry as per the tile adhesive and grout manufacturer's instructions for wetrooms.**

If tile adhesive or grout falls into the gully immediately clean it up.

The grate when installed must be horizontal and flat. It also must be level with the ceramic tile surface and not at an angle or on a slope.

NOTE: Once installed and the grout is fully dry, check for leaks before using.

Fix Tiles to BS5385 Standard.

It is important to follow the tile adhesive and grout manufacturer's instructions on drying times for the tile adhesive and grout when using in a wetroom. Drying/setting time will be sufficiently longer than a shower tray installation. If you are uncertain, contact your tile adhesive and grout manufacturers' Technical Helplines before starting.

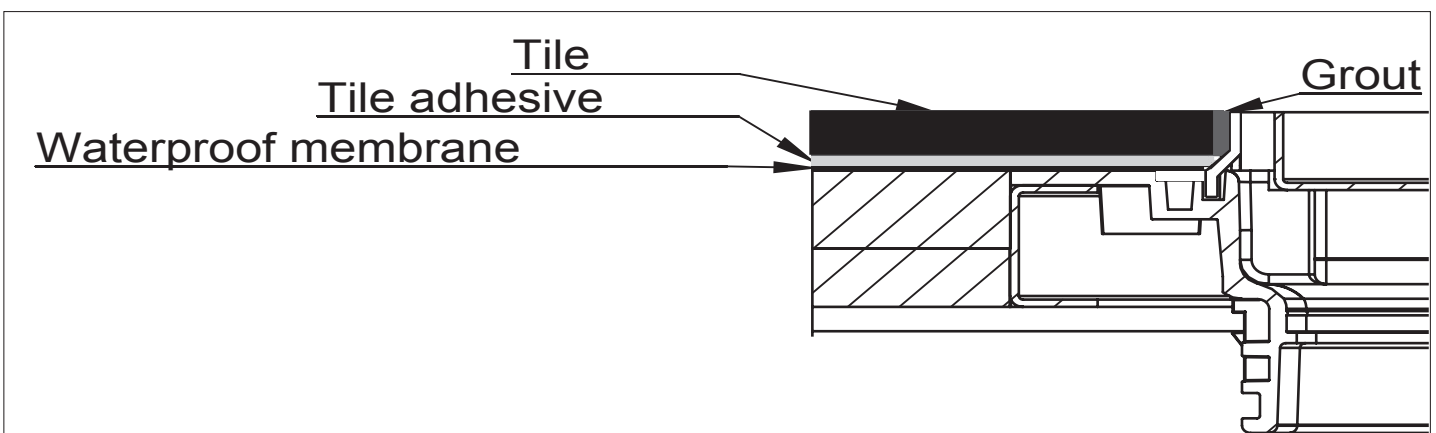
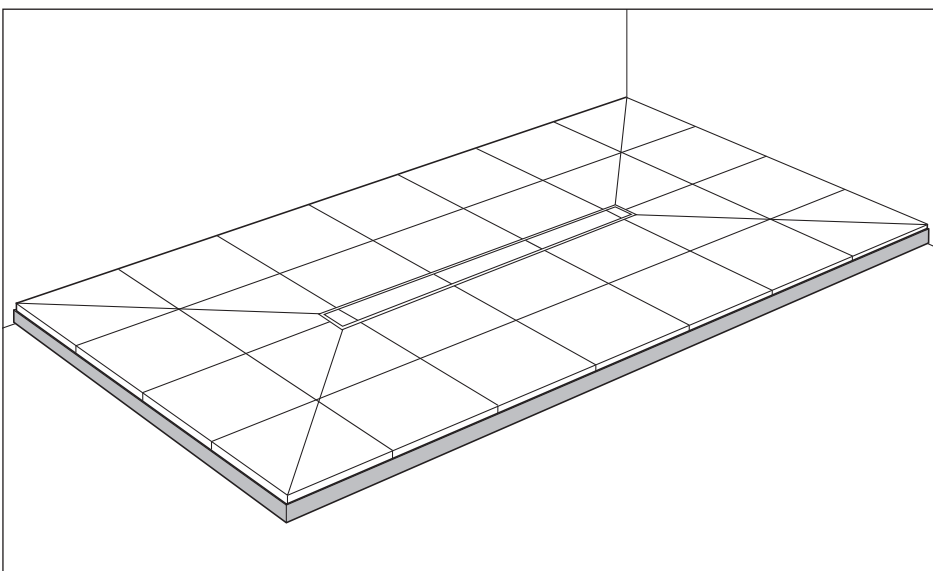





# Purusline Living

## Wetroom Solution 800

### Installation instructions for concrete floor

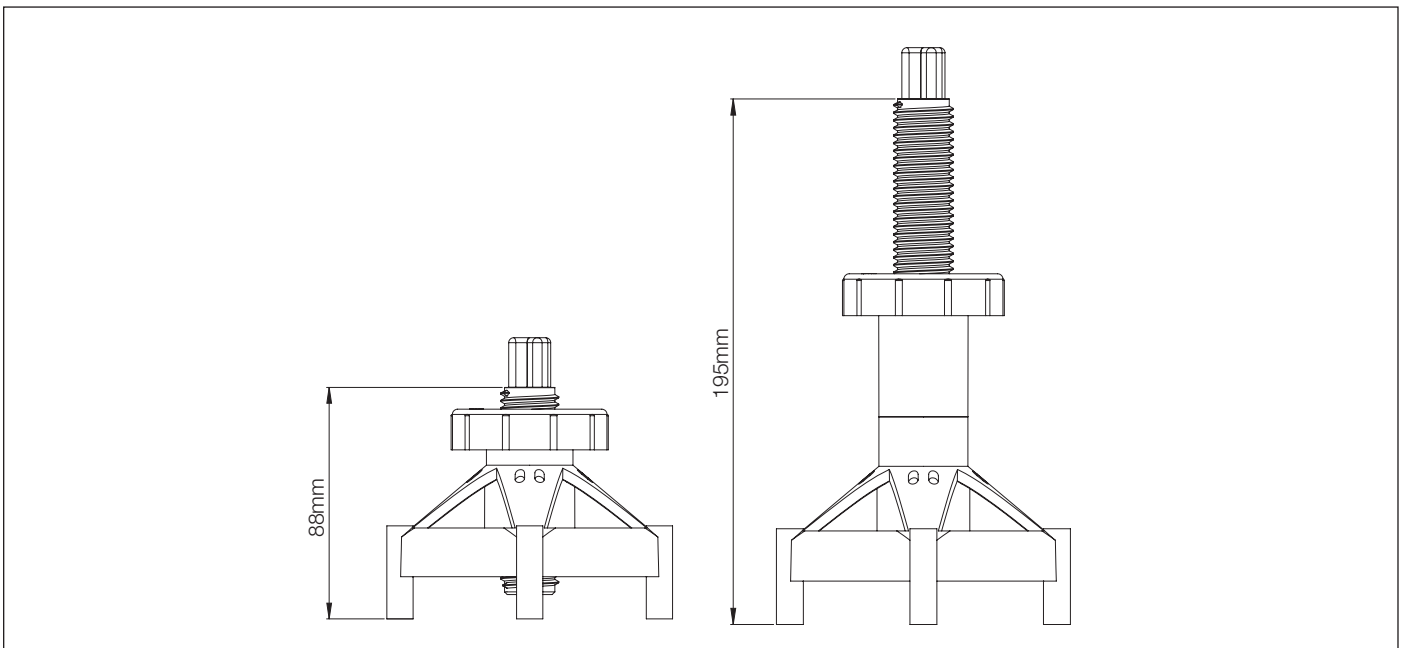
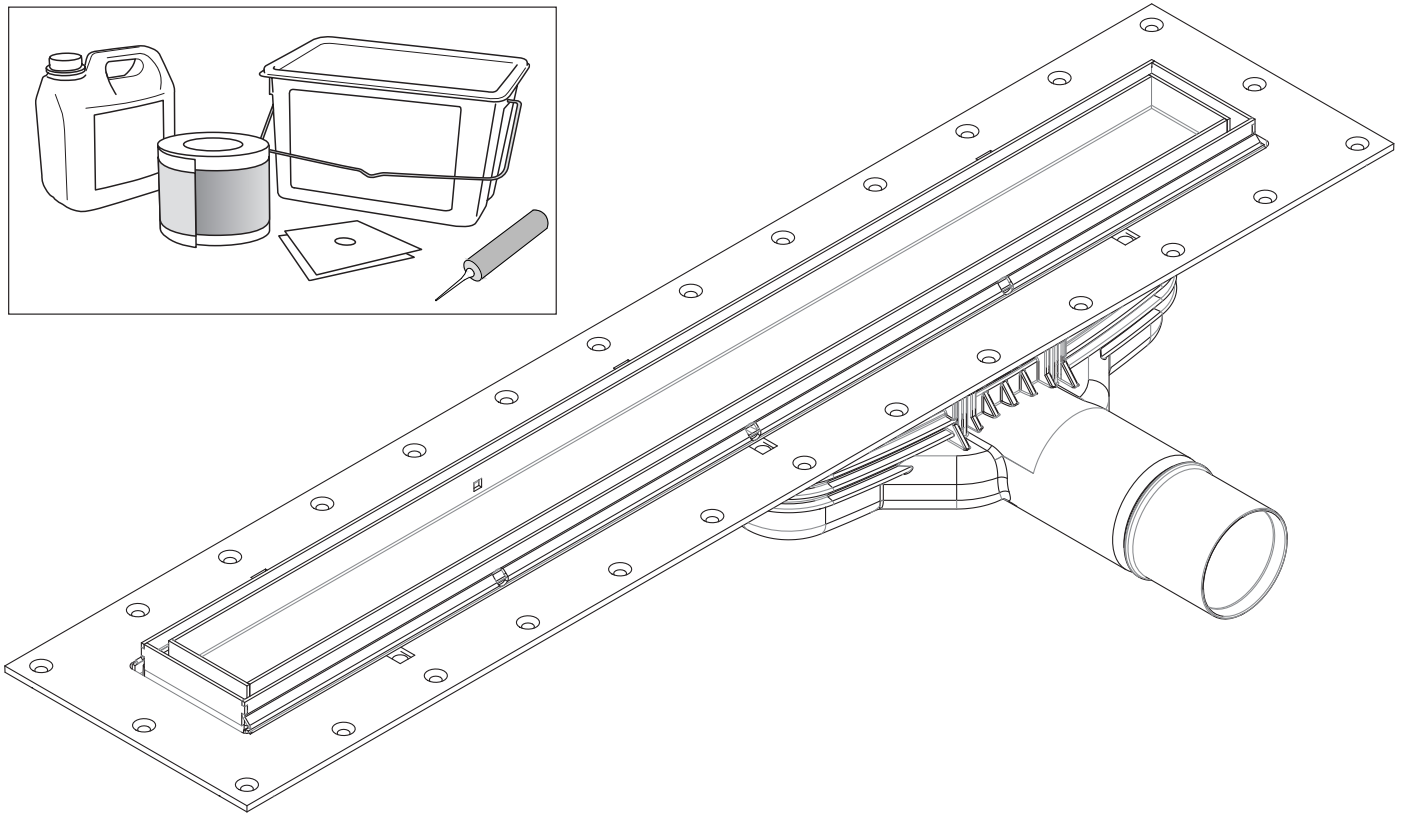
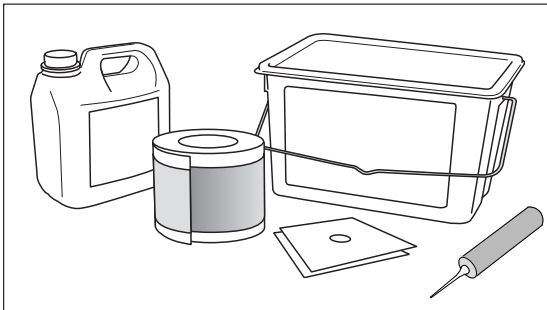

## Important

Read all the pages of these instructions fully and thoroughly before you commence installing and keep in a safe location for future reference.

## Plumbing

All plumbing work should be carried out by a fully qualified professional plumber. 1½ inch ABS pipe adapter/connector provided.

## CHECK LIST/SAFETY NOTES

- Ensure you have all the contents supplied before installation. If you do not have all the contents do not install. Contact your supplier straight away.
- Check all the contents for damage. If any parts are damaged do not install. Contact your supplier straight away.
- The grate when installed must be horizontal and flat. It also must be level with the tile surface and not at an angle or on a slope.
- Check where all pipes, electrical cables and all other services are prior to drilling, cutting and screwing into walls, ceilings and floors.
- Ensure your tools for installation are fit for purpose and follow manufacturer's instructions provided with the tools.
- Do not use power tools on the screws of the Purusline Living Gully.
- The maximum height for the tile insert grate is 12mm. Combined tile and adhesive should not exceed 12mm. It is recommended that a maximum of 10mm porcelain tile is used.
- If you have tiles, adhesive and/or underfloor heating exceeding the 12mm height then you will need the Stainless Steel Grate Solution 800 which has a maximum height level of 26mm.
- Remove any skirting boards in the room.
- Any gaps or holes/damage in the walls and floors must be made good.
- Always ensure the installation and working areas are kept safe, especially from children and pets.
- Work safely; ensure that no tools are lying around and that the working and installation areas are clean and tidy at all times.
- Ensure that all sharp devices such as knives and saws have covers on them at all times. Do not carry knives in pockets.
- Safety goggles, masks and gloves should be worn at all times.
- When installing into concrete build falls to the gully with screed so water can run into it. The minimum for this should be 1:150 to ensure the flow of water to the floor trap and no more than 1:50 to reduce the risk of slipping. A nominal 2% falls is usually used.
- Concrete floors should be primed with Puragum Primer.
- The Puragum Tanking Kit covers 7-8m<sup>2</sup>. Ensure you have enough to cover all of the floor and walls.
- Use C2 tile adhesive and C2 grout, always checking the manufacturers' minimum drying times for wetrooms.

- Check the litres per minute output of your shower/showers before choosing the waste outlet especially if you are going to use a shower pump. The flow rate for the gully is 60 litres per minute for the Side and Side Side waste outlets, and 30 litres per minute for the Low waste outlet. Do not exceed these limits unless using multiple gullies.

## Underfloor heating

If your underfloor heating is an electrical system, ask the manufacturer if the electric underfloor heating mat is suitable for a wetroom and if the temperature can be controlled by a thermostat, if not, do not use. Always follow the Underfloor Heating Manufacturer's Instructions of how to install the system.

The underfloor heating system must be fully buried into concrete/screed/tile adhesive/levelling compound before the tanking is applied. Please refer to the Underfloor Heating and Tile Adhesive/Grout manufacturers' instructions for guidance or contact the supplier's technical help line before installing.

From the bottom upwards you should fix in this order: the floor surface; underfloor heating mat fully embedded into screed/concrete/suitable levelling compound; wetroom tanking, tile adhesive, tiles, tile grout.

When the Tanking System, The Tile Adhesive and Tile Grout is fully cured for a wetroom (always check the Tile Adhesive and Tile Grout manufacturers' drying out times for a wetroom), then turn on the Thermostat according to the manufacturer's instructions only by 3°C a day to a maximum of 30°C. This will take 10 days in the first instance. After that you can select your ambient temperature. Never go over 30°C.

## Packaging

Once packaging has been unpacked and used it should always be taken to the nearest local authority waste collection site for recycling. The packaging must not be thrown away with normal household waste.

## Liability

The Manufacturer will not accept any liability for failure if the Purusline Living Wetroom Solution has been installed incorrectly and with disregard to the instructions.

**It is extremely important when installing a wet room that you fully seal/tank the room. Take your time. The tanking of the room is the most important part. Check all tapes and gaskets are secure and bonded before tiling.**

**It is also extremely important to follow the manufactures instructions for the drying time for the C2 tile adhesive and grout when being used for a wetroom. It will be significantly longer than for tiles in a shower tray situation.**

**After the drying period, ensure that you test your room after tiling to ensure the room is fully watertight. Do not use the wet room/shower room until tests are thoroughly completed. The completed wetroom must be left to dry to the minimum stated in the manufacturer's instructions for the adhesive and grout for a wetroom. It may be beneficial to use an epoxy resin grout as it will cure quicker and offer better water resistance.**

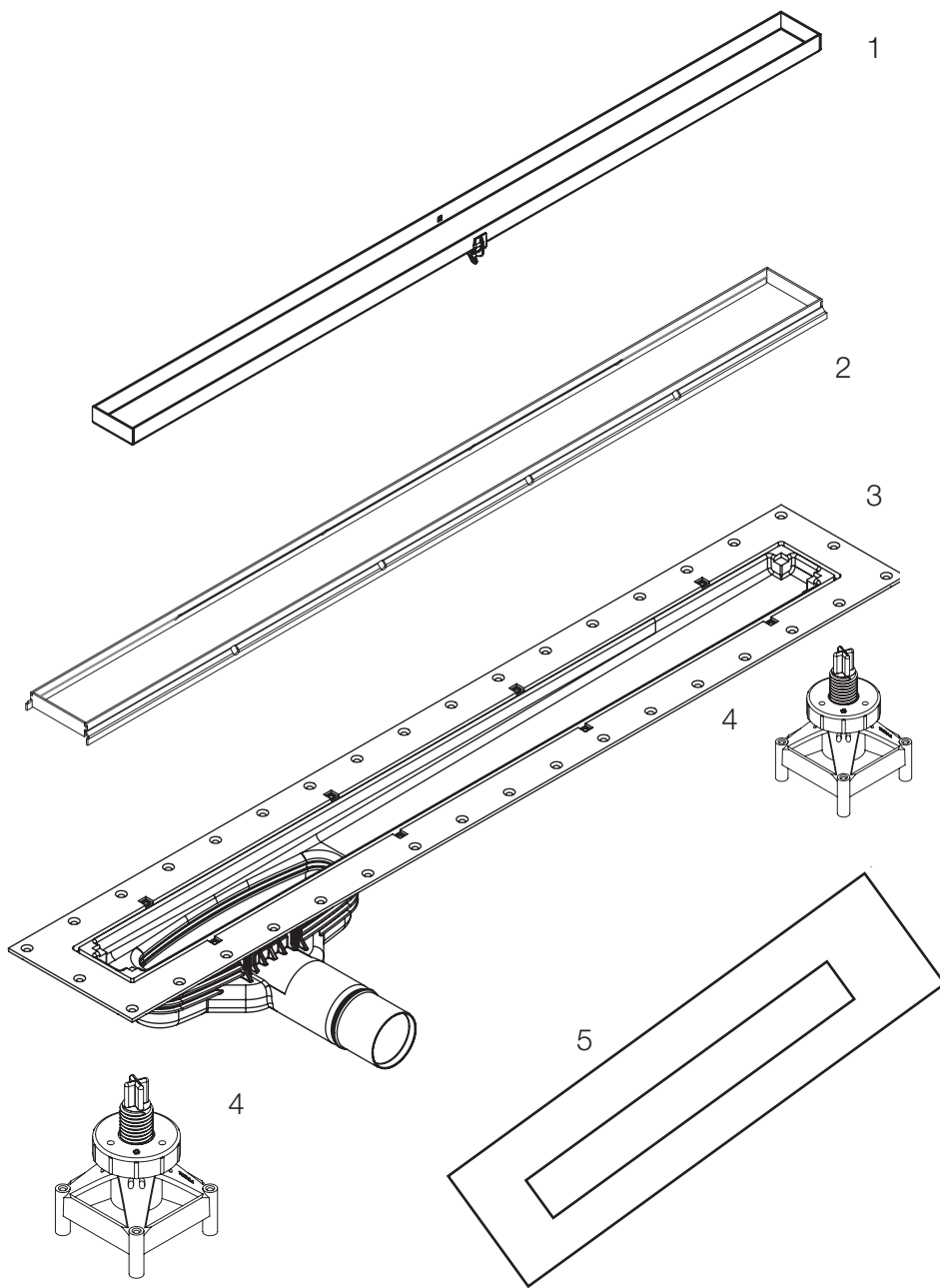

Purusline Living Linear Wetroom Solution

- 1. Tile insert grate x1
- 2. Tile insert frame x1
- 3. Purusline Living gully x1
- 4. Concrete support x2
- 5. Gasket membrane x1

The concrete support is made of plastic. It is a tool to fix the gully at the casting of concrete screed.

The concrete support has a min height of 88mm and a max height of 195mm with a distance case at 50mm.

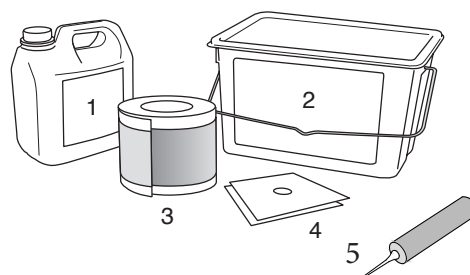
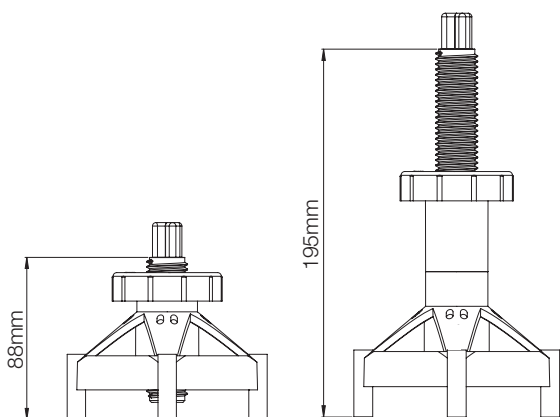

Wetroom Tanking Kit

- 1. Primer
- 2. Puragum
- 3. Pura Elastomeric Tapes
- 4. Pura Pipe Covers x2
- 5. MS Polymer

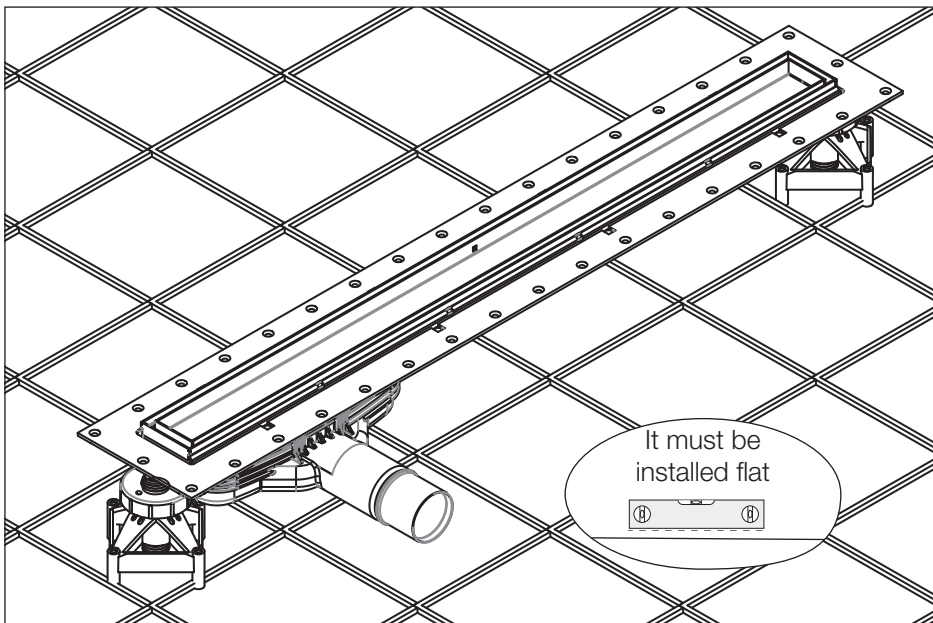

The Purusline Living gully is placed on the surface and the height is adjusted by the concrete support.

Ensure your DPM below the concrete is not broken.

Connect the gully to the waste pipe. The installation is attached to the reinforcement with steel wire.

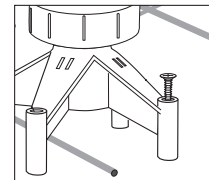

The concrete installation support may be nailed or screwed to the surface. Ensure your DPM is not broken.

**Waste pipes**

If your waste pipe is an ABS plastic 1½ inch or 42.9mm pipe then you can use the supplied 42.9mm (1½ inch) ABS pipe adapter provided for solvent welding and connecting to the 42.9mm (1½ inch) waste pipe.

The push fit end must be fully inserted into the gully prior to connecting to the waste pipe. The gully adapter can then be solvent welded to the waste pipe by a fully qualified professional plumber.

If the waste pipe is not an ABS plastic 1½ inch or 42.9mm pipe then a mechanical fixing connector must be used to connect the gully outlet to the waste pipe by a fully qualified professional plumber. Once the gully has been connected to the waste pipe and tested for leaks by your fully qualified plumber, you can pour the concrete.

The showering area should have falls built into the subfloor so that the water runs towards the drain. The minimum for this should be 1:150 to ensure the flow of water to the floor trap and no more than 1:50 to reduce the risk of slipping. A nominal 2% falls is usually used.

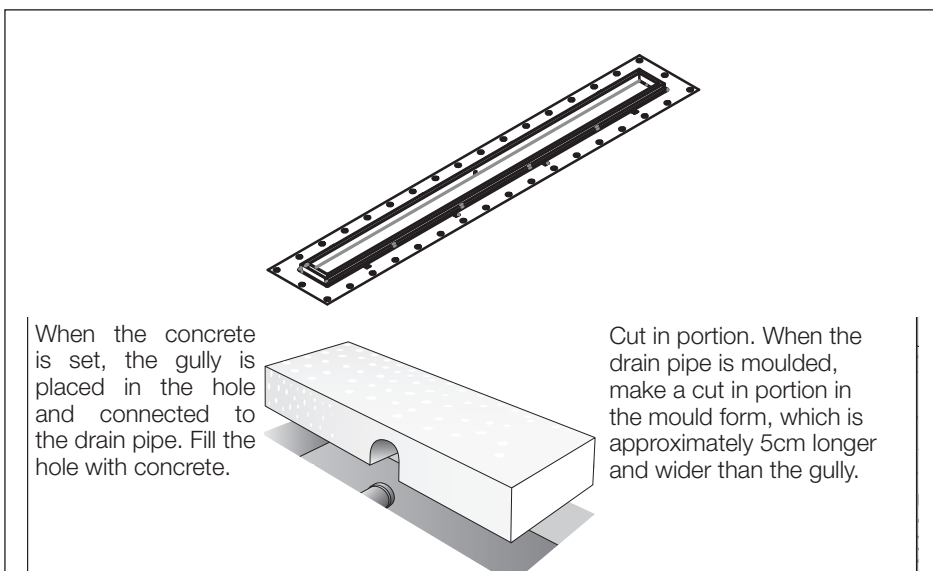

When the concrete is set, the gully is placed in the hole and connected to the drain pipe. Fill the hole with concrete.

Cut in portion. When the drain pipe is moulded, make a cut in portion in the mould form, which is approximately 5cm longer and wider than the gully.

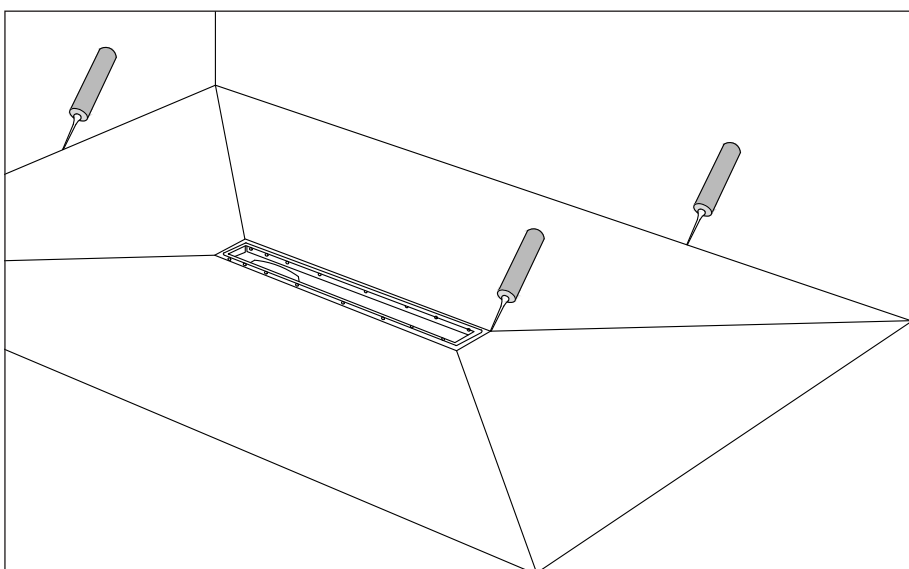

If you have existing walls covered with plaster or plasterboard use Puragum Primer to seal the walls. If the walls are not covered, then clad walls with panels or plaster board (not supplied) and coat with Puragum Primer (follow the instructions provided in the tanking kit), and allow to dry. Once the floor is cemented, then prime and allow to cure with Puragum Primer from the tanking kit.

Then totally fill the following gaps with the MS Polymer, smoothing down as you go along and ensuring that all the gaps are fully sealed:

- 1). between the gully and the concrete;
- 2). between the walls and the floor.

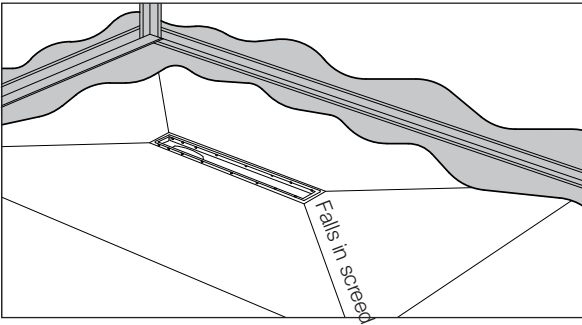

Take the Pura Elastomeric Tapes and dry cut to all wall and floor joints.

Once the MS Polymer has tacked over, using a brush or roller apply the Puragum to all wall and floor joints one at a time. Apply the Pura Elastomeric Tapes while the Puragum is still wet, firmly smoothing down the tape as you go so there are no air pockets or ridges left and the tapes are fully adhered.

It is important to apply the tapes to the Puragum as quickly as possible. Now allow to dry for 3 hours.

Now fix the gasket into position with MS Polymer. First check if it fits properly then place the gasket into position making sure it is centred and mark the outer and inner perimeters onto the surface below. Remove the gasket. With the MS Polymer, create a zigzag pattern in the marked area and then with a clean flat scraper, smooth the MS Polymer in the entire marked area to a thickness of 1mm to 1½mm and only overlapping the marked lines by 1-2mm. By doing this you will ensure the whole gasket is fixed. Fix the gasket in position. Making sure you are pressing with reasonable amounts of pressure, push out all the creases and air bubbles beneath the gasket. Go over the whole gasket with a clean wide flat scraper pushing it into the MS Polymer. Double check there is adhesion and make sure it is completely fixed.

Now allow to dry for 3 hours.

Now cover the whole floor, tape, gasket and walls with one coat of Puragum and allow to dry for another 3 hours (minimum), then apply a second coat. Ensure the Puragum goes up the sides of the tile insert grate ensuring you overlap the gasket with the two coats of Puragum (when applying the Puragum ensure the weep holes are kept intact). Leave to dry for a minimum of 24 hours before tiling depending on site conditions. **Once the second coat of Puragum has fully cured, check the tapes and gasket are fully secure and sealed before tiling.**

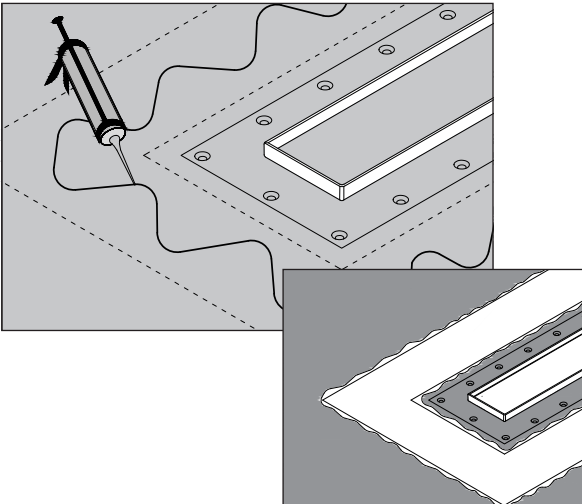

Ensure the tanking kit is installed as per the instructions. Ensure you follow the tanking kit instructions and that all porous surfaces such as concrete and plasterboard are primed with Puragum Primer. Also ensure that the tapes and membranes are fully secure before tiling.

**Ensure you keep to the minimum drying times. Drying times could be longer depending on site conditions.**

Tile to the desired pattern, followed by the insert cover using EN12004 C2 classified tile adhesive applied using a notched trowel in accordance with the code of practice BS5385.

Fix the tiles with adhesive that fastens to stainless steel. Use a small straight edge up against the gully gap so as to prevent the tile adhesive falling into the gully body.

Finally grout the gaps with flexible, water proof, anti-mould grout, ensuring that no grout falls into the gully body. **Allow to dry as per the tile adhesive and grout manufacturer's instructions for wetrooms.** It is important to follow the manufacturer's advice on drying times for the tile adhesive and grout when using in a wetroom. Drying/setting time will be sufficiently longer than shower tray installation. If you are uncertain, contact your tile adhesive and grout manufacturers' Technical Helplines before starting.

If tile adhesive or grout falls into the gully immediately clean it up. The grate when installed must be horizontal and flat. It also must be level with the ceramic tile surface and not at an angle or on a slope. Fix Tiles to BS5385 Standard.

NOTE: Once installed and the grout is fully dry, check for leaks before using.

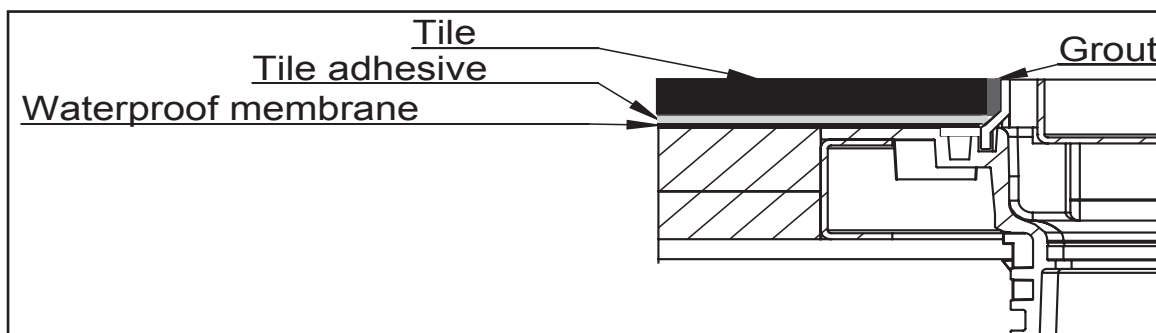
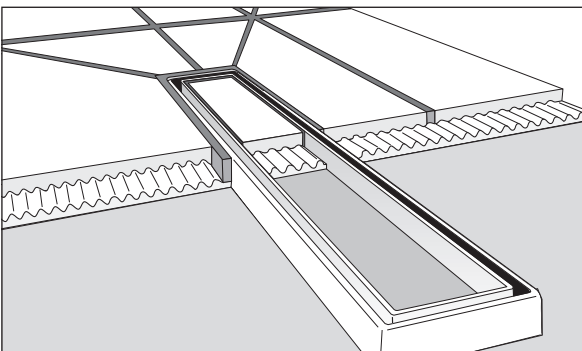
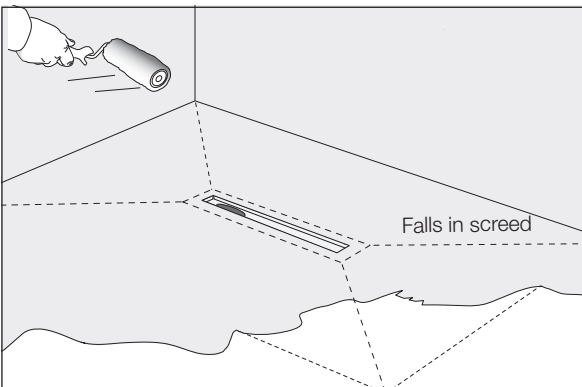



# CLEANING AND MAINTENANCE

These Cleaning and Maintenance instructions must be handed to the client upon completion.

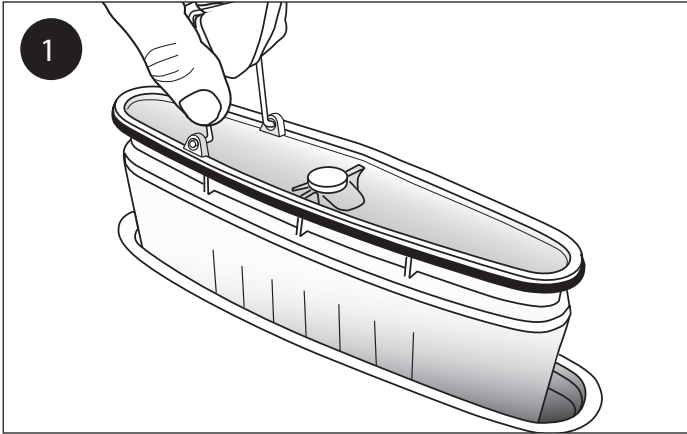

1. Lift out the NOOD water trap as above.
2. If necessary, rinse the NOOD water trap using water as shown.
3. Only use water and do not use any bleach-based or caustic cleaning products or hair dye products whilst the NOOD is in position. Remove the NOOD first.
4. Replace the NOOD water trap with two thumbs at each short end.
5. If you have a blockage in the waste pipe system, remove the NOOD before rectifying/cleaning.

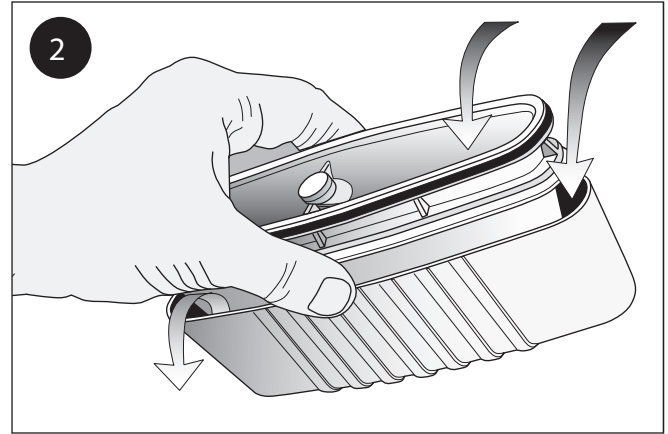

Hold the NOOD water trap with the spring loaded body fully open whilst rinsed clean. Use only water and, if required, a small brush to clean the NOOD. **It is important that you do not use bleach, bleach-based or caustic cleaning products on or in the NOOD water trap.**

If bleach is to be used in the pipework, then the NOOD water trap must first be removed and bleach poured directly into the pipework.

Make sure the gaskets are completely clean so the NOOD is watertight. Ensure when placed back that the gully is fully inserted so the gasket is watertight using two thumbs at each short end.



Our ongoing product development may lead to changes in execution, design and construction, for which we accept no liability.