



E.H. Wachs
600 Knightsbridge Parkway
Lincolnshire, IL 60069
www.ehwachs.com

Low Clearance Split Frame, Models 204-1420 User's Manual



E.H. Wachs Part No. 60-MAN-07
Rev. C, August 2014

Revision History:

Original	March 2011
Rev. 1	July 2011
Rev. 2	August 2011
Rev. A	December 2011
Rev. B	March 2014

Copyright © 2014 E.H. Wachs. All rights reserved.
This manual may not be reproduced in whole or in part
without the written consent of E.H. Wachs.

**EU DECLARATION OF CONFORMITY
WITH
COUNCIL DIRECTIVE 2006/42/EC**

Issue Details:	DATE: 1/1/2011	Place: E.H.Wachs, Lincolnshire, IL USA
Directives:	Machinery Safety Directive 2006/42/EC	
Conforming Machinery:	<u>Split Frame Machines:</u> Low-Clearance Split Frame (LCSF) Small-Diameter Split Frame (SDSF)	
Model Number:	60-000-XX, 60-AIR-XX, 60-HYD-XX 80-0000-AX, 80-0000-RA, 80-4000-XX	
Serial Number:		
Manufacturer:	E.H. Wachs 600 Knightsbridge Parkway Lincolnshire IL 60069 USA	
Responsible Representative:	Orbitalum Tools GmbH Josef-Schüttler-Str. 17, 78224 Singen Germany Tel. +49 (0) 7731 - 792 872 Fax +49 (0) 7731 - 792 566	
Harmonised Standards & Other Technical Standards/Specifications Applied or Referenced:	EN ISO 12100-1:2003 + A1:2009 EN ISO 12100-2:2003 + A1:2009 EN 60201-1:2006 (for electric machines) EN ISO 13857:2008 EN 982:1996 + A1:2008 (E) (for hydraulic machines) EN 983:1996 (for pneumatic machines) EN 13732-1:2006 EN ISO 14121-1:2007 EN ISO 13850:2008 (for pneumatic machines)	
Provisions with which Conformity is Declared:	Essential Health and Safety Requirements of Annex 1 of the Machinery Directive	
We hereby certify that the machinery described above conforms to the provisions of Council Directive 2006/42/EC on the approximation of the laws of the Member States relating to the safety of machinery.		
Signed:		
Signatory:	Pete Mullally Quality Manager E.H. Wachs	

Table of Contents

Chapter 1: About This Manual	1
Purpose of This Manual	1
How to Use The Manual	1
Symbols and Warnings	2
Manual Updates and Revision Tracking	3
Technical File Responsible Party	3
Chapter 2: Safety	5
Safe Operating Guidelines	5
Safe Operating Environment	6
Operating and Maintenance Safety	6
Hydraulic Powered Equipment	6
Pneumatic Powered Equipment	7
Loss or Shut-Off of Power Supply	7
Safety Alerts in This Manual	7
Protective Equipment Requirements	8
Protective Clothing	8
Eye Protection	8
Hearing Protection	8
Safe Operation of the LCSF	8
Intended Uses	8
Proper Use of the LCSF	9
Misuse	9
Potential Hazards	10
LCSF Safety Features	12
Stop-on-Release Power Control	12
Paddle-Style Trip Lever	13
Remote Operation Option	14
Guidelines for Safe Setup, Operation, and Service	14
Pre-Operation Checklist	14
Operating Safety	14
Operator Position	15
Service Checklist	17
Disconnecting Power	17
Safe Lifting and Handling	18
Machine Weights	20
Installation Procedures	22
Safety Labels	22
Chapter 3: Introduction to the Equipment	27
Overview of the LCSF	27
Features	27
Models and Model Designation	28

LCSF Components	29
Standard Equipment	30
Split Frame Machine	30
Tool Slides	30
Clamp Pad Extensions	32
Trip Assembly	32
Drive Motor	32
Hand Tool Kit	33
Accessories	34
Noise Levels	35
Operating Envelopes	35
LSCF Models 204 and 206	36
LCSF Models 408, 610, 612, and 814	37
LCSF Models 1016 and 1420	38
Low Clearance Parting Slide, 60-402-04	39
Low Clearance Beveling Slide, 60-403-04	40
Extended Parting Slide, 60-415-00	41
Extended Parting Slide, 60-416-00	42
Universal Counterbore Slide, 60-405-UC	43
Front Drive Pinion Assembly, 60-425-03	44
1.5 HP Right-Angle Air Drive, 60-423-00	45
2.5 HP Right-Angle Air Drive, 60-423-01	45
2.5 HP Right-Angle Reversible Air Drive, 60-4010-01	46
Hydraulic Drive, 60-424-02	47
Chapter 4: Assembly, Disassembly, and Storage	49
Machine Disassembly for Storage	49
Storage/Shipping Cases	50
Storage Guidelines	52
Chapter 5: Operating Instructions	53
Planning the Operation	53
Tool Selection	55
Parting-Only Operation	56
Parting/O.D. Beveling Operation	56
O.D. Beveling-Only Operation	58
Single-Point Beveling	59
Operating Envelopes	59
Low Clearance Slides (60-402-04/60-403-04)	59
Extended “Standard” Slides (60-415-00/60-416-00)	60
Lifting and Rigging the LCSF	61
Models with Lift Eyebolts	61
Setting Up the LCSF	65
Clamp Leg Set-Up	65
Set-Up for In-line Pipe	67

Set-Up for Open-Ended Pipe	71
Installation on Vertical Pipe	71
Positioning the Machine for the Cut	71
Clamp Pad Centering Procedure	72
Install Tool Slides and Tooling	77
Standard Slides	77
Low-Clearance Slides	78
Install the Tooling	78
Dual Tooling Setup	82
Install the Trip Assembly	84
Install the Drive Motor	88
Air Motor	88
Hydraulic Motor	89
Cutting Operation	93
Counterboring	97
Planning the Operation	97
Counterbore Set-up	102
Cutting the Counterbore	103
LCSF Cutting Accessories	106
Remote Operation with the SF ACM	107
Connectors	107
Control Panel Reference	108
Locating the ACM at the Worksite	109
Operating the ACM	110
Adjusting the Output Pressure	115
Using the Venting Quick Disconnect	118
Configuring the Air Drive for the ACM	119
Air Fitting	119
Air Trigger Modification	120
Chapter 6: Routine Maintenance	123
Daily Maintenance	123
Lubrication	123
Tool Slides	123
Split Frame	123
Air Motor	123
Recommended Air Motor Lubricants	124
Servicing the SF ACM	125
Chapter 7: Service and Repair	127
Troubleshooting	127
Adjusting the Bearings	128
Pre-2009 Machine	128
2009 and Later Machines	135
Tool Slide Adjustment	140

Air Motor Maintenance	146
Disassembling Air Motor Subassemblies	146
Right Angle Head	146
Gear Case	146
Motor	146
Handle	146
Reassembly	147
Motor	147
Air Motor Vanes	147
Right Angle Head	148

Chapter 8: Parts Lists and Drawings..... 149

Model 204 (4-inch LCSF), 60-000-04.....	150
Model 206 (6-inch LCSF), 60-000-06.....	151
Model 408 (8-inch LCSF), 60-000-08.....	152
Model 610 (10-inch LCSF), 60-000-10.....	153
Model 612 (12-inch LCSF), 60-000-12.....	154
Model 814 (14-inch LCSF), 60-000-14.....	155
Model 1016 (16-inch LCSF), 60-000-16.....	156
Model 1420 (20-inch LCSF), 60-000-20.....	157
Stationary Ring Assembly (Models 204 through 814).....	158
Stationary Ring Assembly (Models 1016 and 1420).....	159
Wiper Kit Assemblies, 60-552-01 and 60-552-02.....	160
Pinion Housing, 60-412-00.....	161
Front Drive Pinion Housing, 60-425-03.....	162
Clamp Legs, 60-127-XX.....	163
Trip Assembly, 60-401-00.....	164
Low Clearance Parting Slide, 60-402-04.....	165
Low Clearance Beveling Slide, 60-403-04.....	166
Extended Parting Slide, 60-415-00.....	167
Extended Beveling Slide, 60-416-00.....	168
Universal Counterbore Slide, 60-405-UC.....	169
1.5 HP Air Drive, 60-423-00.....	170
1.5 HP Air Drive, Ported Exhaust, 60-407-00.....	171
2.5 HP Air Drive, 60-423-01.....	172
2.5 HP Reversible Air Drive, 60-4010-00.....	173
Hydraulic Drive, 60-424-02.....	174
Hydraulic Drive, 60-424-01 (OBSOLETE).....	175
Split Frame Air Control Module (60-420-00).....	176
Air Control Module Subassembly (60-375-00).....	177
Air Control Module Subassembly (60-375-00).....	178
Air Control Module Schematic (60-420-00).....	179

Chapter 9: Accessories and Spare Parts..... 181

Accessories	181
-------------------	-----

Tooling	183
Hydraulic Power Units	187
Recommended Spares	187
Chapter 10: Ordering Information	189
Ordering Replacement Parts	189
Repair Information	189
Warranty Information	190
Return Goods Address	190

Chapter 1

About This Manual

PURPOSE OF THIS MANUAL

This manual explains how to operate and maintain the Low Clearance Split Frame (LCSF). It includes instructions for set-up, operation, and maintenance. It also contains parts lists, diagrams, and service information to help you order replacement parts and perform user-serviceable repairs.

LCSF models are available in a wide range of sizes. **This manual covers models from 4-inch capacity (model 204) through 20-inch capacity (model 1420).**

Carefully read Chapter 2, Safety, and follow all guidelines for safe operation of the LCSF.

HOW TO USE THE MANUAL

This manual is organized to help you quickly find the information you need. Each chapter describes a specific topic on using or maintaining your equipment.

Use these instructions to operate and maintain the equipment.

SYMBOLS AND WARNINGS

The following symbols are used throughout this manual to indicate special notes and warnings. They appear in the outside column of the page, next to the section they refer to. Make sure you understand what each symbol means, and follow all instructions for cautions and warnings.



This is the **safety alert symbol**. It is used to alert you to **potential personal injury hazards**. Obey all safety messages that follow this symbol to avoid possible injury or death.



WARNING

A WARNING alert with the safety alert symbol indicates a potentially hazardous situation that **could** result in **serious injury or death**.



CAUTION

A CAUTION alert with the safety alert symbol indicates a potentially hazardous situation that **could** result in **minor or moderate injury**.



A CAUTION alert with the damage alert symbol indicates a situation that will result in **damage to the equipment**.



This is the **equipment damage alert symbol**. It is used to alert you to **potential equipment damage situations**. Obey all messages that follow this symbol to avoid damaging the equipment or workpiece on which it is operating.



IMPORTANT

An IMPORTANT alert with the damage alert symbol indicates a situation that **may** result in **damage to the equipment**.



NOTE

This symbol indicates a user note. **Notes** provide additional information to supplement the instructions, or tips for easier operation.

MANUAL UPDATES AND REVISION TRACKING

Occasionally, we will update manuals with improved operation or maintenance procedures, or with corrections if necessary. When a manual is revised, we will update the revision history on the title page.

Current versions of E.H. Wachs manuals are also available in PDF format. You can request an electronic copy of this manual by emailing customer service at sales@ehwachs.com.

You may have factory service or upgrades performed on the equipment. If this service changes any technical data or operation and maintenance procedures, we will include a revised manual when we return the equipment to you.

TECHNICAL FILE RESPONSIBLE PARTY

The low clearance split frame is manufactured by E.H. Wachs at the following address:

E.H. Wachs
600 Knightsbridge Parkway
Lincolnshire, IL 60069
U.S.A.

The following organization is the responsible party for maintaining the LCSF technical file in the EU:

Orbitalum Tools GmbH
Josef-Schüttler-Str. 17
78224 Singen
Deutschland

Chapter 2

Safety

E.H. Wachs takes great pride in designing and manufacturing safe, high-quality products. We make user safety a top priority in the design of all our products.

Read this chapter carefully before operating your E.H. Wachs equipment. It contains important safety instructions and recommendations.

SAFE OPERATING GUIDELINES

Follow these guidelines for safe operation of all E.H. Wachs equipment.

- **READ THE OPERATING MANUAL.** Make sure you understand all setup and operating instructions before you begin. Keep this manual with the machine.
- **INSPECT MACHINE AND ACCESSORIES BEFORE USE.** Before starting the machine, look for loose bolts or nuts, leaking lubricant, rusted components, and any other physical conditions that may affect operation. Properly maintaining the machine can greatly decrease the chances for injury.
- **ALWAYS READ STICKERS AND LABELS.** Make sure all labels and stickers are in place, clearly legible, and in good condition. Refer to “Safety Labels” later in this chapter for label locations on the machine. Replace any damaged or missing safety labels; see Chapter 10 for ordering information.
- **KEEP CLEAR OF MOVING PARTS.** Keep hands, arms, and fingers clear of all rotating or moving parts. Always turn the machine off and disconnect the power source before doing any adjustments or service.
- **SECURE LOOSE CLOTHING AND JEWELRY.** Secure or remove loose-fitting clothing and jewelry, and securely bind long hair, to prevent them from getting caught in moving parts of the machine.
- **FOLLOW SAFE PROCEDURES FOR HANDLING LUBRICANTS.** Refer to the manufacturer’s instructions and the Material Safety Data Sheets.



Look for this symbol throughout the manual. It indicates a personal injury hazard.

Safe Operating Environment

- Do not use this equipment in a potentially explosive atmosphere. Fire or explosion could result, with the risk of serious injury or death.
- Provide adequate lighting to use the equipment, in accordance with worksite or local regulations.
- **KEEP WORK AREA CLEAR.** Keep all clutter and nonessential materials out of the work area. Only people directly involved with the work being performed should have access to the area.

Operating and Maintenance Safety

- This equipment is to be operated and maintained only by qualified, trained personnel.
- Make sure the equipment is stable when attached to the workpiece for the operation. Ensuring stability of the installed tool is the responsibility of the operator.
- Make sure the workpiece is supported adequately for installation of the equipment. This includes supporting any workpiece “fall-off” section when severing the workpiece. Ensuring support of the workpiece is the responsibility of the operator.
- Tooling on any cutting equipment—including lathe tools, saw blades, milling tools, etc.—may get very hot. Do not touch tooling until you have made sure it is cool enough to handle.
- Wear gloves when removing or cleaning up chips and cutting debris. Chips can be very sharp and cause cuts.
- Before performing any service on the equipment, disconnect the power source. Follow all lock-out/tag-out procedures required at the worksite.

Hydraulic Powered Equipment

- Hydraulic components such as hoses, motors, and manifolds will get hot during operation and may cause burns. Do not touch hydraulic components, except for operator controls, during or after operating the machine.
- **Hydraulic injection injury**—A pinhole in a hydraulic hose or fitting can eject fluid with enough force to pierce skin. Check hoses and fittings regularly for leaks. **Do not use bare hands to check for leaks while the system is pressurized.** If you suspect a leak, move a piece of paper or cardboard at least 6 inches (15 cm) over the suspicious area and watch for fluid spraying on the surface.



WARNING

Injection of hydraulic fluid through the skin is a serious injury that can result in infection, tissue damage, and possible loss of limb. **Seek medical treatment immediately.** First aid is not sufficient treatment for injection injury.

Pneumatic Powered Equipment

- Air motors may get hot during operation and may cause burns. Do not touch the air motor, except for operator controls, during or after operating the machine.
- Before disconnecting the air line from the equipment, always turn off air at the source and bleed all residual air pressure at the air motor.

Loss or Shut-Off of Power Supply

For all power sources, follow all lock-out/tag-out procedures required at the worksite when disconnecting or servicing the equipment.

- **PNEUMATIC POWERED EQUIPMENT**—The 60-420-00 Air Control Module (ACM) prevents accidental restarting after loss of power. If operating the LCSF **without** the ACM, disconnect the air supply from the machine after loss of power to prevent accidental restarting of the machine. Lock out the power supply immediately.
- **HYDRAULIC POWERED EQUIPMENT**—Disconnect hydraulic lines from the LCSF hydraulic manifold to prevent accidental restarting of the machine. Lock out the power supply immediately.
- **ELECTRIC POWERED EQUIPMENT**—If the electric drive shuts off because of its built-in thermal protection, disconnect the motor from the power source immediately.

Safety Alerts in This Manual

The following alerts are used throughout this manual to indicate operator safety hazards. In all cases, these alerts include a notice describing the hazard and the means to avoid or reduce risk. Carefully read all safety alerts.



This icon is displayed with any safety alert that indicates a personal injury hazard.



WARNING

This safety alert, with the personal injury hazard symbol, indicates a potentially hazardous situation that, if not avoided, **could** result in **death or serious injury**.



CAUTION

This safety alert, with the personal injury hazard symbol, indicates a potentially hazardous situation that, if not avoided, **could** result in **minor or moderate injury**.

Protective Equipment Requirements

Protective Clothing

Wear safety shoes when operating or servicing the equipment. Serious injury could result from dropping the machine or its components.

Do not wear gloves while operating the machine. Gloves can become entangled in moving parts, resulting in serious injury. Gloves may be worn when setting up the machine or cleaning up after the operation, but take them off when operating the machine.



NOTE

Gloves should be worn when cleaning up chips and other cutting debris. Chips can be very sharp and can cause serious cuts. **Do not wear gloves when the machine is operating.**

Eye Protection

Always wear impact-resistant eye protection while operating or working near this equipment.

For additional information on eye and face protection, refer to Federal OSHA regulations, 29 Code of Federal Regulations, Section 1910.133., Eye and Face Protection and American National Standards Institute, ANSI Z87.1, Occupational and Educational Eye and Face Protection.

Hearing Protection

This equipment can produce noise levels above 80 dB. Hearing protection is required when operating the equipment. The operation of other tools and equipment in the area, reflective surfaces, process noises, and resonant structures can increase the noise level in the area.

For additional information on hearing protection, refer to Federal OSHA regulations, 29 Code of Federal Regulations, Section 1910.95, Occupational Noise Exposure and ANSI S12.6 Hearing Protectors.

SAFE OPERATION OF THE LCSF

Intended Uses

The low clearance split frame is designed to O.D. mount on in-line or open-ended pipe, and perform cut-off and weld prep (beveling, counterboring, and J-prep) operations. It uses cold-cutting lathe techniques, with a variety of accessories and tooling for different cutting applications.

Make sure to follow all safety guidelines and procedures required for machining operations at the work site, including personal protective equipment (PPE). Do not use the LCSF in a manner that violates these guidelines.

Proper Use of the LCSF

- The LCSF should only be used by trained, qualified operators.
- The workpiece must be within the operating capacity of the LCSF model you are using. See operating envelope information and drawings in Chapter 3.
- Make sure the operating environment allows you to mount the machine securely and squarely on the workpiece.
- Make sure there is adequate clearance around the LCSF and workpiece to operate the machine controls as described in the operating instructions (Chapter 5).
- Mount the LCSF with the pinion housing positioned for convenient mounting and operation of the drive motor.
- Use the LCSF only on empty, depressurized pipe.

Misuse

- Do not attempt to mount or operate the LCSF on non-cylindrical workpieces.
- Do not attempt to mount or operate the LCSF on any workpiece to which it cannot be securely mounted.
- Do not attempt to mount or operate the LCSF on any workpiece that is not stable enough to hold the LCSF.
- Do not mount the LCSF on the “fall-off” side of the cut line, unless you adequately rig and support the LCSF and workpiece.
- Do not disable any safety feature of the LCSF or remove any safety labeling. Replace worn or damaged safety labels immediately. (See “Safety Labels” later in this chapter.)

Potential Hazards

The following figures illustrate potential hazards of operating the low clearance split frame. Refer to the description of each hazard for guidelines on safe operation.

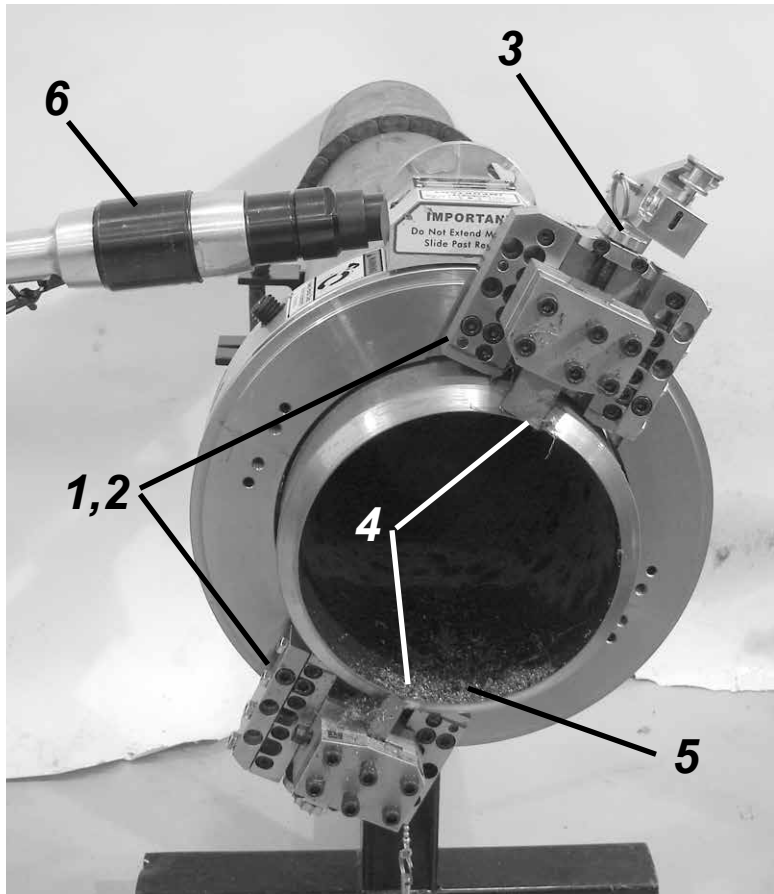

Figure 2-1. Potential operating hazards of the LCSF. See the descriptions below.

- 1. Rotating ring**—Keep clear of the rotating ring and tool slides when operating the LCSF. Contact with moving parts can cause serious injury.
- 2. Entanglement hazard for gloves or clothing**—Do not wear gloves or loose-fitting clothing when operating the LCSF. They can become entangled with moving parts, resulting in serious injury.
- 3. Starwheel/trip pinch point**—Operate the trip using the trip lever only. Do not touch any part of the trip assembly, other than the lever, when operating the LCSF or when rotating it manually for any reason.
- 4. Sharp cutting tools**—Cutting tools used with the LCSF can be very sharp. Be careful when handling the tools, and stay clear of them when the machine is operating.
- 5. Chips**—The metal debris from the cutting process can be very sharp and very hot. Use care in cleaning debris from the machine and cleaning up the work area. Stop the machine before clearing chips. Use appropriate gloves when handling chips.
- 6. Hot surfaces**—Air motors and hydraulic components such as hoses, manifolds, and motors can become very hot during operation. Make sure these components are not hot before touching them.



Figure 2-2. Potential operating hazards of the LCSF. See the descriptions below.

7. Air motor connection—A pressurized air line can cause serious injury if it comes loose. Make sure the air line is secured to the equipment with a pin or other appropriate fastener.

8. Fall-off workpiece—When you are severing the workpiece, make sure the fall-off section is supported or that a catch device is in place. A support chain and scaffolding are shown in the picture.

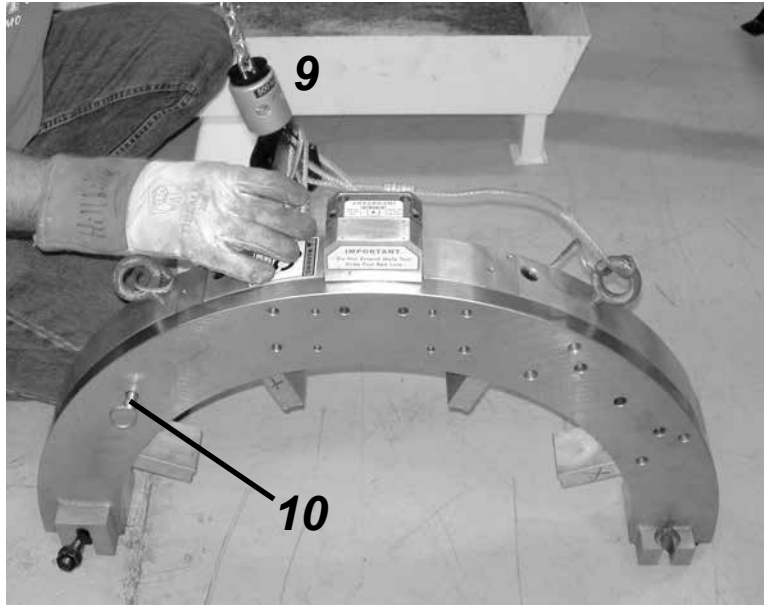

Figure 2-3. Potential operating hazards of the LCSF. See the descriptions below.

- 9. Lifting the machine**—Use care when lifting the LCSF and its components to avoid injury. Machines and components heavier than 40 lb (18 kg) should be lifted by two people or with a lifting device. LCSF models 610 and larger are provided with lifting eyes for rigging and lifting. See “Machine Weights” later in this chapter for weights of LCSF models 204-1420 and accessories.
- 10. Splitting the ring**—Alignment pins are provided to keep the rotating and stationary rings together when splitting the ring. Make sure you insert the pins before separating the ring halves. If the pins are not inserted, the rotating ring could fall out of the stationary ring, causing personal injury and/or damage to the machine.

LCSF Safety Features

The design of the low clearance split frame incorporates the following features for safe operation.

Stop-on-Release Power Control

All drives for the LCSF (pneumatic and hydraulic) require the operator to hold the power control on to operate the machine. When the operator releases the power control, the LCSF stops immediately.



WARNING

Do not disable or override the stop-on-release feature. Letting the machine run when you are not holding the power control could result in serious injury.

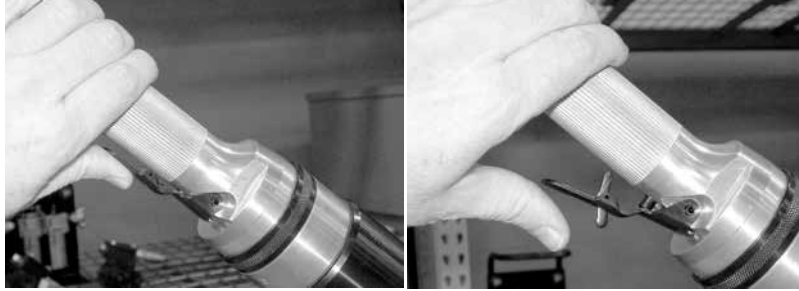

Figure 2-4. Hold the air motor trigger to operate the LCSF (left). When you release the trigger (right), the air motor shuts off.

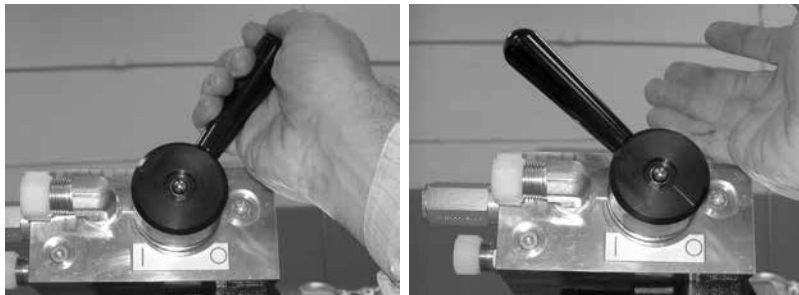

Figure 2-5. Hold the hydraulic lever to operate the LCSF (left). When you release the lever (right), the hydraulic motor shuts off.

Paddle-Style Trip Lever

The LCSF trip design allows the operator to engage and disengage the trip from behind the machine, without reaching into the operating space of the rotating ring and slides. The paddle trip lever moves the trip pin in and out to control engagement of the trip.

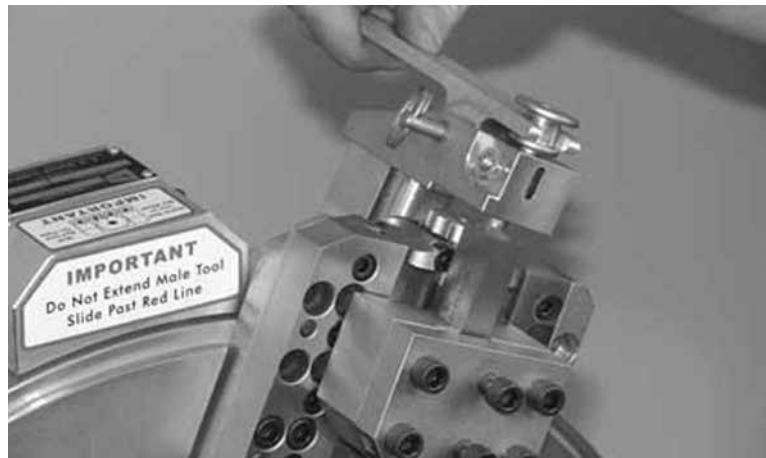

Figure 2-6. The paddle-style trip lever allows you to engage and disengage the trip from the back of the LCSF, without putting your hands in the way of moving components.

Remote Operation Option

Remotely controlled operation is available as an option for all LCSF drives types.

- For pneumatic drives, order the remote control panel (part no. 60-420-00). The control panel is provided with its own operating instructions.
- For hydraulic drives, contact E.H. Wachs customer service to discuss your operating environment and requirements.

Guidelines for Safe Setup, Operation, and Service

Pre-Operation Checklist

Every time you use the LCSF, perform the following checks to make sure it is in good operating condition:

- Check that all safety components are operating properly.
- Inspect it for damage or wear that could affect operation and safe use of the machine. Repair any defective component before using the machine.
- Make sure the machine is clean and properly lubricated.
- Make sure that tooling is sharp and in good condition. Poor quality tooling can cause difficult cutting and the possibility of machine malfunction and/or injury.
- Check power connections (pneumatic, hydraulic, or electric) to make sure they are in good condition.

Operating Safety

- Stop the LCSF drive motion to clear chips or make any machine adjustments.
- For parting (cut-off) operations, use a catch device to prevent the cut-off piece of the pipe from falling.
- Keep air and hydraulic hoses and electrical cords away from moving parts while operating the machine.

Operator Position

The preferred position for operating the LCSF is behind the stationary ring, on the mounting side of the cut line.



Figure 2-7. If possible, stand behind the LCSF to stay clear of moving parts while operating the controls.

If the operating environment does not allow you to stand behind the LCSF, make sure you install the machine so that you can operate the controls without coming in contact with moving parts.



Figure 2-8. When operating the LCSF from the front, stand to the side of the machine to operate the controls without reaching across the rotating ring.

Some accessories, such as the universal counterbore slide, require that you operate them from in front of the machine. Stand in a position that allows you to operate the machine controls without contacting moving parts.



Figure 2-9. When using accessories that require you to operate their controls (shown with universal counterbore slide), stand in a position where you can operate the machine without contacting moving parts.

Service Checklist

- Disconnect power from the LCSF during service. See instructions in the following section.
- Remove accessories such as drive assemblies and tool slides unless they are part of the service procedure.

Disconnecting Power

The following photos show the means of disconnecting power for the LCSF. Follow all lock-out/tag-out procedures at your work site.

- **PNEUMATIC POWER**—To disconnect power from the pneumatic LCSF, remove the air line from the air motor coupling.



	WARNING
Before disconnecting the air line, always turn off air at the source and bleed all residual air pressure at the air motor. Disconnecting the air line while under pressure could result in serious injury.	



Figure 2-10. Disconnect pneumatic power by removing the air line from the pneumatic drive.

- **HYDRAULIC POWER**—To disconnect power from the hydraulic LCSF, remove the hydraulic hoses from the fittings on the manifold.

	WARNING
Hydraulic components such as hoses, motors, and manifolds will get hot during operation and may cause burns. Use appropriate gloves or wait until the components cool before touching them.	

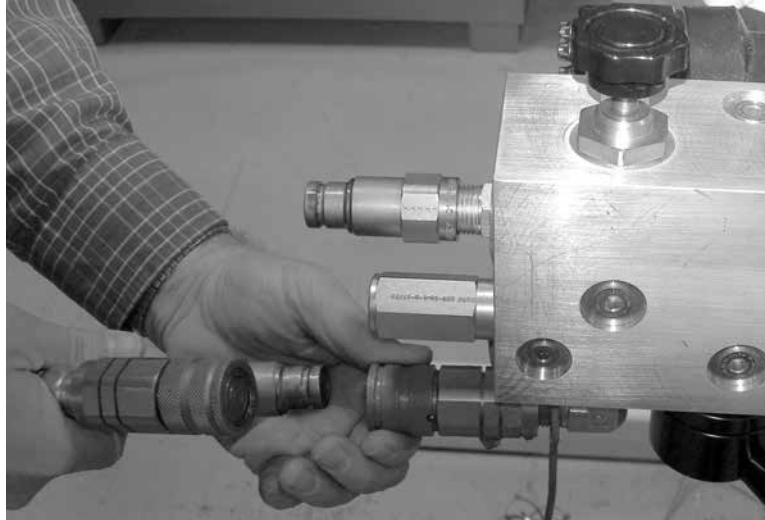

Figure 2-11. Disconnect hydraulic power by removing the hydraulic hoses from the fittings on the manifold.

Safe Lifting and Handling

- Machines or assemblies over 40 lb (18 kg) must be lifted by two people or a lifting device. See the machine weight tables in the following section.
- It is the responsibility of the end user to determine whether a machine or assembly can be lifted by two or more people. A lifting device is recommended for machines or assemblies that cannot be handled easily by two people.
- LCSF models 610 and larger are equipped with eye bolts in the stationary ring for lifting.
- Do not rig or lift the LCSF while power is attached. Whenever possible, remove all accessories (slides, trips, drive assembly, etc.) while lifting and handling the machine.
- Lift the LCSF only at approved lift points, as illustrated in the following figure.

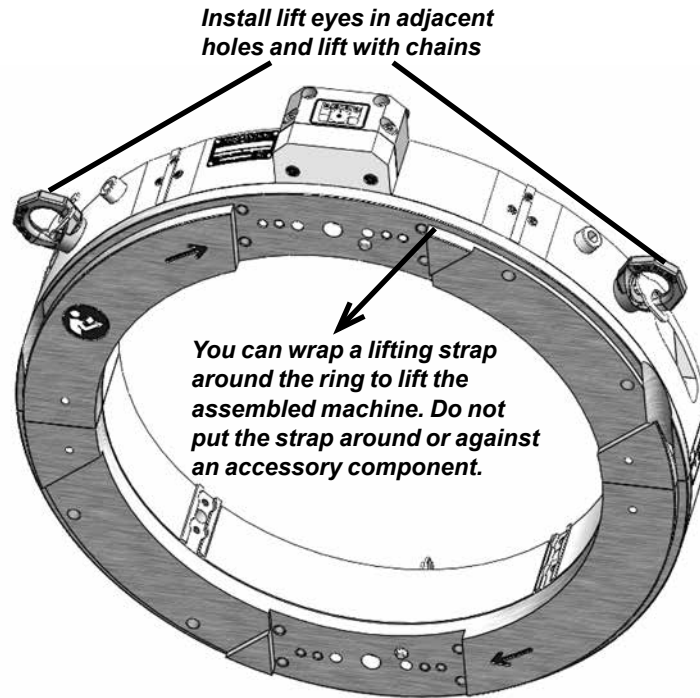

Figure 2-12. When lifting the assembled LCSF, use the lift eyes provided. You can also lift the machine using a lift strap around the ring. (16" machine, model 1016 shown.)

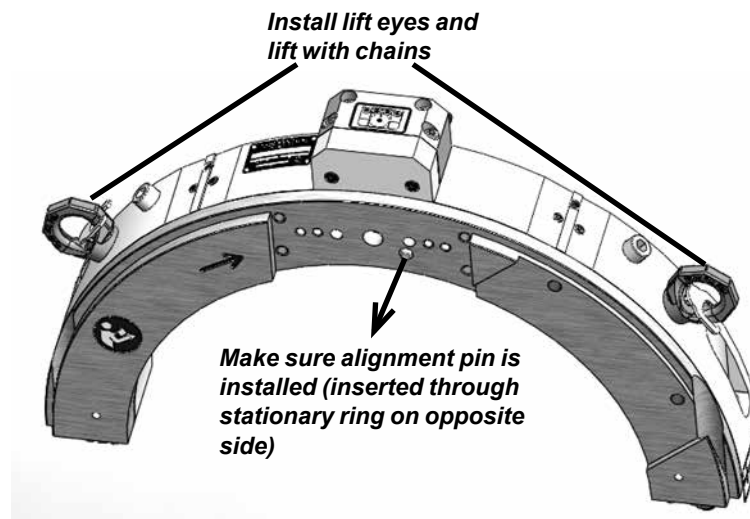

Figure 2-13. To lift a split machine, always use two lift eyes. Make sure the alignment pins are installed.

Machine Weights

Table 1 lists the weights for each LCSF model. Weights are included for the entire machine as well as each separable assembly. Table 2 lists the weights for slides, drives, and other assemblies. To determine lifting weight, add weights of installed components to the machine assembly.

Table 1: LCSF Machine and Assembly Weights

Model Part No.	Full Machine Weight*	Split Ring Weight (Pinion Side)**	Split Ring Weight (Non-Pinion Side)**
204 60-000-04	23.0 lb 11 kg	14 lb (6 kg)	10 lb (4 kg)
206 60-000-06	31 lb 14 kg	17 lb (8 kg)	13 lb (6 kg)
408 60-000-08	37 lb (17 kg)	20 lb (9 kg)	16 lb (7 kg)
610 60-000-10	49 lb (22 kg)	26 lb (12 kg)	22 lb (10 kg)
612 60-000-12	55 lb (25 kg)	29 lb (13 kg)	25 lb (11 kg)
814 60-000-14	59 lb (27 kg)	32 lb (15 kg)	28 lb (13 kg)
1016 60-000-16	77 lb (35 kg)	40 lb (18 kg)	36 lb (16 kg)
1420 60-000-20	92 lb 42 kg	48 lb (22 kg)	44 lb (20 kg)

* With standard pinion housing installed; no slides or drive installed. Add 5.4 lb (2.5 kg) for front drive pinion.

** Rounded to nearest lb/kg. Sum may not add exactly to Full Machine Weight.

Table 2: LCSF Slide Kit Weights

Accessory	Kit Part No.	Component	Part Number	Weight
Low Clearance Slide Kit	60-421-04	Low clearance parting slide (60-402-04)	60-402-04	3 lb (1.4 kg)
		Low clearance beveling slide (60-403-04)	60-403-04	3 lb (1.4 kg)
		Trip assembly (60-401-00)		
Extended Slide Kit	60-422-01	Extended parting slide (60-415-00)	60-415-00	8 lb (4 kg)
		Extended beveling slide (60-416-00)	60-416-00	8 lb (4 kg)
		Trip assembly (60-401-00) and extension blocks (60-417-00)	60-401-00	1.4 lb (0.6 kg)
O.D. Tracking Slide Kit	60-451-00	O.D. Tracking Parting Slide (60-451-01)	60-425-03	8 lb (4 kg)
		O.D. Tracking Beveling Slide (60-451-02)	60-423-00	9 lb (4 kg)
		O.D. Tracking Slide Trip (60-451-03)	60-407-00	9 lb (4 kg)

Table 3: Accessory Slide Weights

Component	Part Number	Weight
Universal Counterbore Slide	60-405-UC	10 lb (4.5 kg)
Bridge slide for model 612 LCSF	60-428-12	60 lb (27.2 kg)
Bridge slide for model 814 LCSF	60-428-14	60 lb (27.2 kg)
Bridge slide for model 1016 LCSF	60-428-16	60 lb (27.2 kg)
Bridge slide for model 1420 LCSF	60-428-20	60 lb (27.2 kg)
EICC for model 610 LCSF	60-4001-1031	45-50 lb (20.5-22.7 kg)
EICC for model 612 LCSF	60-4001-1231	46-51 lb (20.9-23.2 kg)
EICC for model 814 LCSF	60-4001-1431	47-52 lb (21.4-23.6 kg)
EICC for model 1016 LCSF	60-4001-1631	48-53 lb (21.8-24.1 kg)
EICC for model 1420 LCSF	60-4001-2031	51-56 lb (23.2-25.5 kg)

Table 4: Drive Component Weights

Component	Part Number	Weight
Front drive pinion for 204-1420	60-425-03	8 lb (4 kg)
1.5 HP standard pneumatic drive	60-423-00	9 lb (4 kg)
1.5 HP ported pneumatic drive	60-407-00	9 lb (4 kg)
2.5 HP pneumatic drive	60-423-01	13 lb (6 kg)
2.5 HP reversible pneumatic drive	60-4010-01	14 lb (6 kg)
Hydraulic drive	60-424-00	25 lb (11 kg)

Installation Procedures

See the detailed instructions in Chapter 5 for installing the LCSF on the workpiece. Safe installation procedures are provided for mounting the machine on both horizontal and vertical workpieces.

Safety Labels

The following safety labels are provided on the LCSF. If any of these labels is damaged or missing, replace it immediately. See Chapter 10 for ordering information.



Figure 2-14. The ear and eye protection label is attached to the drive motor of the LCSF. Always wear ear and eye protection when operating the equipment. (Part no. 90-401-03.)

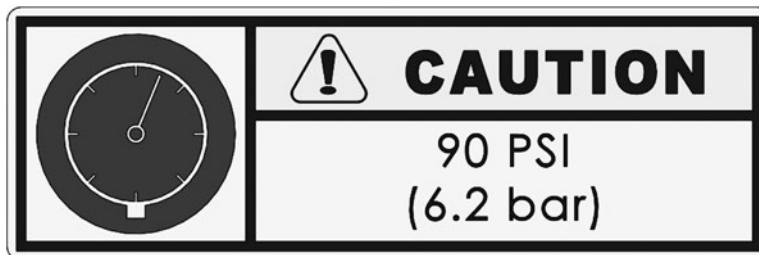

Figure 2-15. The air pressure label is attached to the air drive of pneumatic LCSF models. Do not operate the equipment with greater than 90 psi (6.2 bar) air pressure. (Part no. 90-401-02.)



Figure 2-16. The hydraulic pressure label is attached to the LCSF hydraulic drive. Do not operate the equipment with greater than 2000 psi (138 bar) hydraulic pressure. (Part no. 90-402-01.)



Figure 2-17. The hot surface label is attached to the LCSF drive motor (pneumatic or hydraulic). Drive components may become hot enough to cause burns. Make sure they are not hot before touching them. (Part no. 90-403-00.)



Figure 2-18. Weight labels for the LCSF are attached to the pinion housing. Weights and part no. vary according to LCSF model. (Part no. 60-1279-XX.)



Figure 2-19. The “Keep Hands Clear” label is attached to the stationary ring of the LCSF. Stay clear of moving parts when the LCSF is operating. (Part no. 60-363-00.)

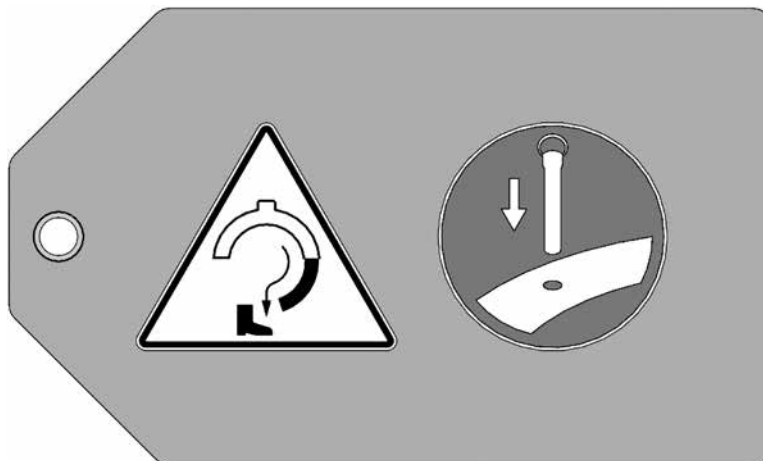

Figure 2-20. The alignment pin tag is attached to the ring on the alignment pin. Make sure to insert the pins before splitting the machine. (Part no. 60-1274-00.)



Figure 2-21. The alignment pin location label is attached to indicate the alignment pin holes. Two labels are on the LCSF, one for each pin location. (Part no. 60-1275-00.)



Figure 2-22. The Read Manual label is attached to the stationary ring of the LCSF. Make sure you understand all operating and maintenance instructions before using the machine. (Part no. 90-900-00.)

Chapter 3

Introduction to the Equipment

OVERVIEW OF THE LCSF

The E.H. Wachs Low Clearance Split Frame Machine (LCSF) is a portable pipe cutting and beveling system developed for on-site operation. The LCSF uses lathe type machining principles, with capabilities for cutting (sever process), beveling (form tool or single point), and counter-boring.

Set-up and operation is quick and simple, and the machine requires little maintenance other than lubrication. Split frame prepping is a safe, clean operation that neither affects the metallurgical qualities of the metal nor places airborne contaminants in the environment.

The LCSF assembly consists of two halves that can be disassembled for installation on the pipe. The stationary frame contains the clamping feet, which secure the machine to the pipe, and the pinion housing, which contains the drive gear that turns the rotating frame. The stationary frame is made from lightweight aluminum material. The rotating frame is of steel construction with hardened bearing raceways and has locations for mounting the tool slides and machining accessories.

Features

- Simple, lightweight, rugged design for cutting and prepping in tight places.
- Works on all sizes, wall thicknesses, and material across the entire range of pipe diameter capacities.
- Self-squaring clamping system for easy set-up.
- Safe cold-cutting for use in any environment.
- Standard air motor drive with options for hydraulic or electric power.
- Adjustable bearings and hardened bearing raceways for maximum dependability and performance.
- Modular accessories for counterboring, compound beveling, J-prepping, heavy-wall cutting, and internal cutting.
- Remote operation capability with optional control module.

Models and Model Designation

The low clearance split frame (LCSF) consists of 15 models for cutting and beveling pipes from 2” (51 mm) to 48” (1219 mm) outside diameter (O.D.). Models up to 1420 (20” capacity) are described in this manual. Each model covers a range of pipe sizes, as described in Table 1.

E.H. Wachs uses a model numbering system that designates the capacity of the machine. All model numbers include the following. (This information is required when ordering parts or tooling.)

Type: **60-000-08**

Model: **SF 408/3**

Serial: **06-1234 (Example)**

“**SF**” Designates Wachs Low Clearance Split Frame Machine, followed by the capacity of the machine, and “/3” which designates the generation of design.

The following numbers indicate the capacity:

- 204 will mount on 2” through 4” pipe
- 206 will mount on 2” through 6” pipe
- 1016 will mount on 10” through 16” pipe

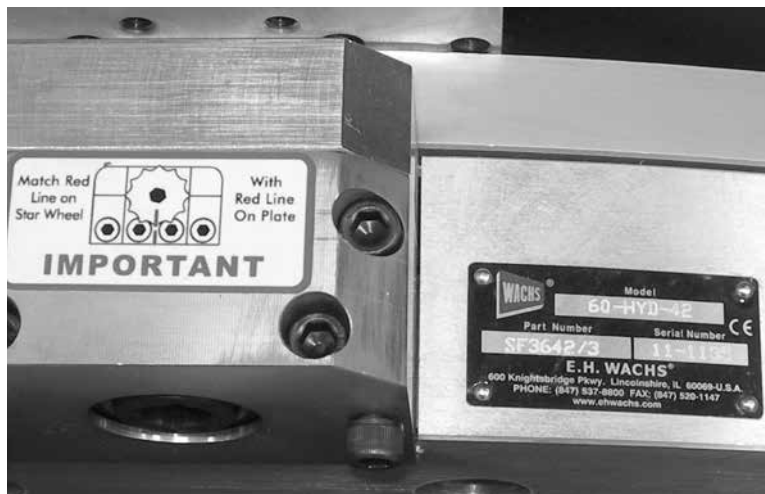

Figure 3-1. The I.D. tag (mounted on the stationary ring next to the pinion housing) identifies the LCSF model, and includes the machine’s serial number.

Table 1: LCSF Models

Model	Part Number	Pipe Size Range	
		Inches	DN
204/3	60-000-04	2"–4"	50-100
206/3	60-000-06	2"–6"	50-150
408/3	60-000-08	4"–8"	100-200
610/3	60-000-10	6"–10"	150-250
612/3	60-000-12	6"–12"	150-300
814/3	60-000-14	8"–14"	200-350
1016/3	60-000-16	10"–16"	250-400
1420/3	60-000-20	14"–20"	350-500

See clamping leg charts in Chapter 5 for measured pipe size capacities.

LCSF COMPONENTS

The complete LCSF configuration includes the following components, illustrated in Figure 3-2.

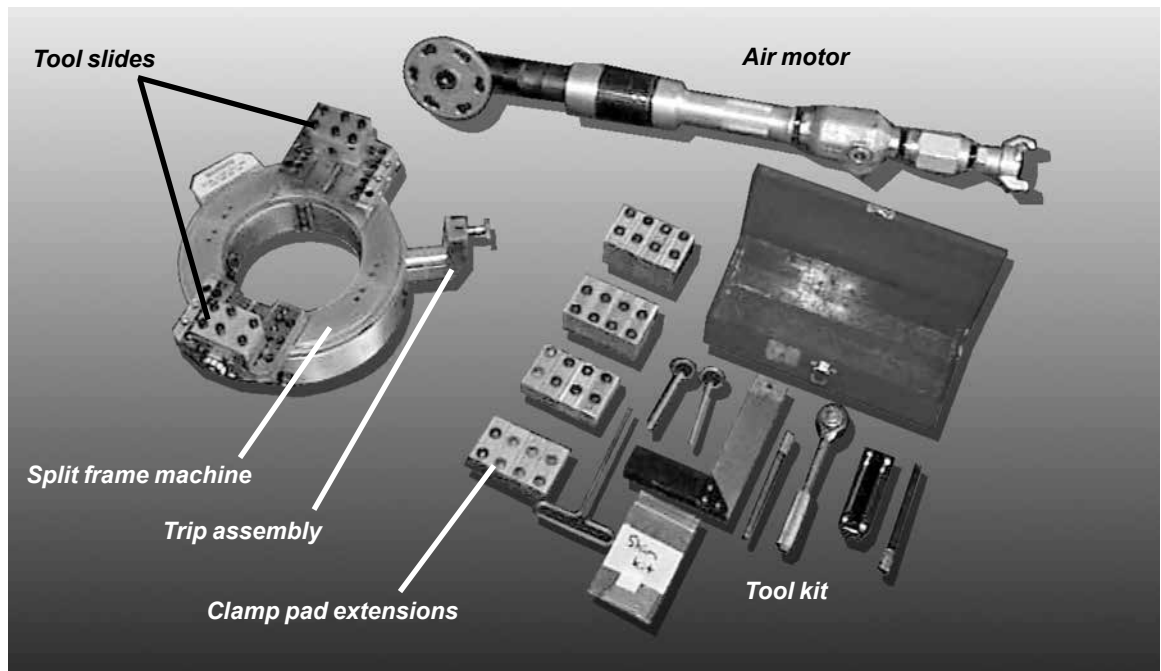

Figure 3-2. Standard equipment provided with the low clearance split frame.

Standard Equipment

Split Frame Machine

The LCSF ring consists of one rotating ring and one stationary ring. Each ring splits into two pieces. When assembled, the rotating ring and stationary rings are integrated and split apart simultaneously for mounting on in-line piping applications. These rings are preassembled and adjusted prior to leaving the factory.

Figure 3-3 shows the assembled LCSF.

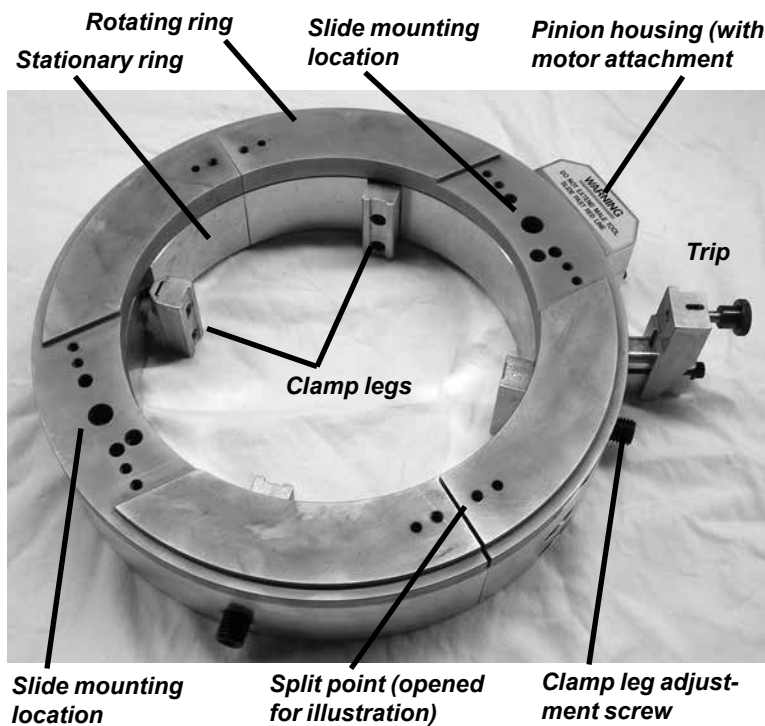

Figure 3-3. The photo shows the components of the LCSF.

Tool Slides

Two sizes of tool slides are available for model 204-1420 LCSFs: **Extended** and **Low Clearance** slides. Extended slides are standard on the models 204-1420. The low clearance slides are special order slides used when minimal radial clearance is required. Check the packing list to see which slides you should have received with your LCSF.

Other types of slides are available for special applications such as counterboring and out-of-round pipe. See the “Accessories” section below and the ordering information in Chapter 9 for information on these slides.

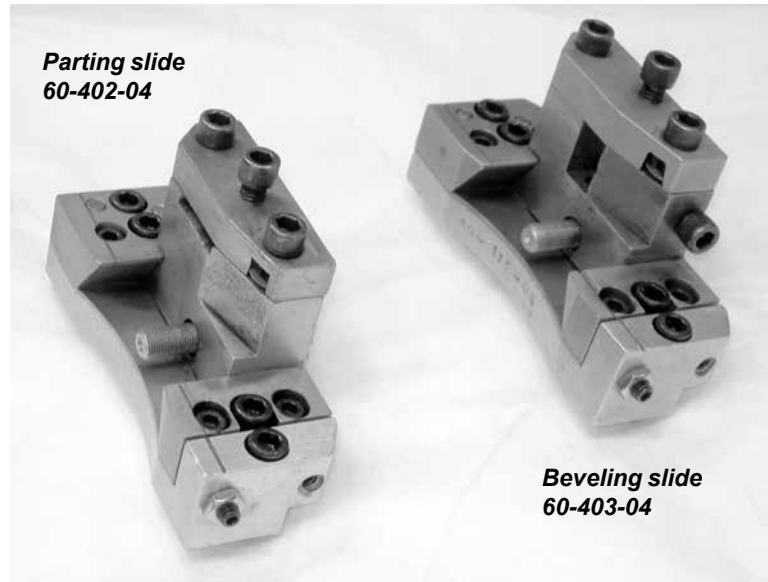

Figure 3-4. The photo shows the low-clearance tool slides, available for applications with limited clearance around the workpiece. Cutting stroke (slide travel) is 0.67" (17 mm).

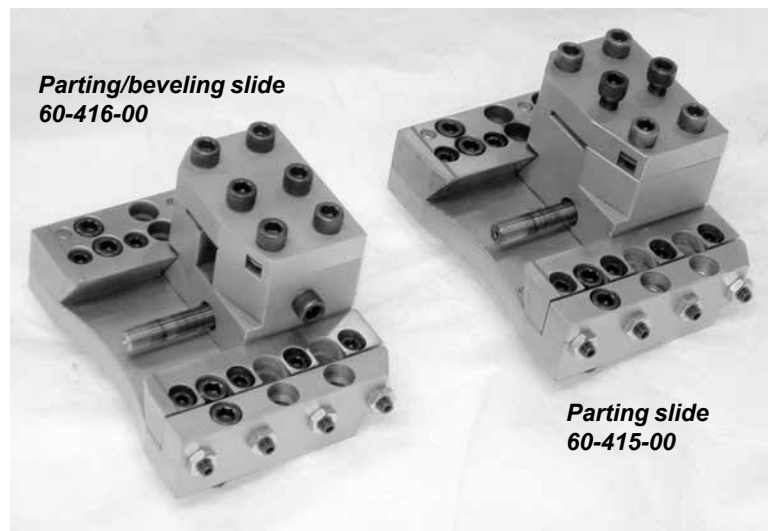

Figure 3-5. The photo shows the extended tool slides, which are standard for LCSF models 204-1420. Cutting stroke (slide travel) is 1.67" (41.8 mm).

Clamp Pad Extensions

Clamp pad extensions lengthen the LCSF clamp legs to allow the LCSF to cover its entire range of pipe diameters. The operating instructions in Chapter 5 include a table of clamp pad requirements for each LCSF size for the pipe diameter range it can cut.



NOTE

Clamp pad requirements are included on the envelope drawings at the end of this chapter.

Trip Assembly

The trip assembly is composed of a trip housing, a trip pin, a trip lever, and two extension blocks. The trip can be engaged or disengaged, depending upon feed requirements, by engaging or disengaging the trip lever.

Drive Motor

The standard LCSF drive is an **air motor**. Two air motor sizes are available:

- A 1.5 HP motor is standard with LCSF models 204-1420 (available in conventional or right-angle configuration).
- A 2.5 HP motor is optional for LCSF models 204-1420 (available in single-direction or reversible configuration).

Both air motors are interchangeable by design and can be used on any size LCSF as needed. The 1.5 HP air drive requires 55 cfm air flow at 90 psi (1,557 l/m @ 6.3 bar). The 2.5 HP air drive requires 65 cfm at 90 psi (1,841 l/m @ 6.3 bar).

A **hydraulic drive** is available as an option. The hydraulic drive requires 8-15 gpm hydraulic flow rate at 1500-2000 psi (30-57 l/m @ 103-138 bar).

Electric drives are available as special-order items. Contact E.H. Wachs customer service to discuss requirements.

Table 2: LCSF Drive Options

Drive Option	Part No.	Description	Input Requirements
Air Drive	60-423-00	Right angle 1.5 HP	55 cfm at 90 psi (1,557 l/m @ 6.3 bar)
	60-407-00	Right angle 1.5 HP with ported exhaust	55 cfm at 90 psi (1,557 l/m @ 6.3 bar)
	60-423-01	Right angle 2.5 HP	65 cfm at 90 psi (1,841 l/m @ 6.3 bar)
	60-4010-01	Right angle reversible 2.5 HP	65 cfm at 90 psi (1,841 l/m @ 6.3 bar)
Hydraulic Drive	60-424-01	Hydraulic motor with adapter	8-15 gpm, 1500-2000 psi (30-57 l/min, 103-138 bar)
Electric Drive	(Special)	Electric motor with adapter; special order item	Varies depending on requirements

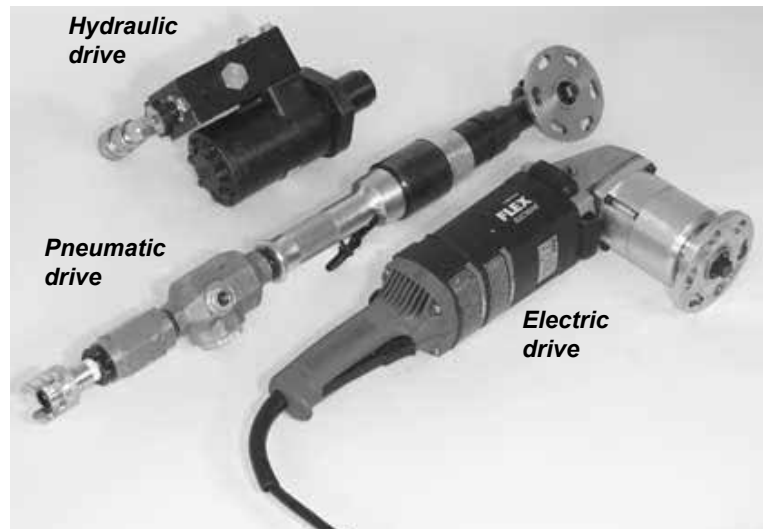

Figure 3-6. The photo shows the drive options available with the LCSF.

Hand Tool Kit

Each LCSF is delivered from the factory with all hand tools necessary for setup and operation. Kit number 60-600-00 is provide with LCSF models 204 through 1420. The following table lists the hand tools provided with the LCSF.

**Table 3: LCSF Hand Tool Kit, Models 204-1420
(Part No. 60-000-00)**

Description	Part #
Hex Wench Set, 5/64" - 1/4"	90-800-06
Deadblow Hammer	60-814-00
3/8" Hex Long Arm Wrench	90-800-10
1/4" Hex Driver Long Socket, 1/2" Drive	90-800-18
7/16" Combination Wrench	90-800-38
Square, 8"	90-800-54
1/2" Drive Ratchet Wrench	90-800-63
Scale, 6"	90-800-70
3/8" Hex Driver Long Socket, 1/2" Drive	90-800-76
Tool Box	60-227-00

Other tools may be required to perform certain maintenance operations. These are specified in the instructions for those procedures.

Accessories

The following accessory equipment is available for use with the LCSF. These items are purchased separately; see Chapter 9 for descriptions and purchasing information.

- Low clearance slides
- Extended stroke slides
- Hydraulic drive
- Electric drive
- Split frame air control module (SF ACM)
- Bridge slide
- O.D. tracking slides
- Counterbore slide
- Front drive pinion
- External-internal casing cutter
- Extension legs
- Dial Indicator

Noise Levels

The noise levels in Table 4 were measured at 1 meter high and 1.6 meters away from the machine, equipped with the air motor drive. (Hydraulic and electric drives have lower noise levels.)

Table 4: LCSF Noise Levels

Continuous “A”-weighted sound pressure level at workstation	62 dBA
Peak “C”-weighted maximum sound pressure	95 dBA
Sound power level emitted by machine	89 dBA

OPERATING ENVELOPES



NOTE

The “operating envelope” is the space required around the workpiece to install and operate the machine.

The drawings on the following pages illustrate the operating envelope for LCSF models 204-1420, and for all slides and accessories.

Use the drawings in this section to plan the operation for your workpiece. See “Planning the Operation” at the beginning of Chapter 5.

LSCF Models 204 and 206

-TABLE-							
MODEL	DIM. "A" OUTER DIAMETER	DIM. "B" INNER DIAMETER	DIM. "C" DRIVE ϕ	DIM. "D"	EXTENSION LEG SET	DIM. "E" MIN. CLAMPING DIA.	DIM. "E" MAX. CLAMPING DIA.
LCSF204/3	9.00 [228.6]	4.75 [120.7]	4.99 [126.6]	6.20 [157.4]	NONE	3.51 [89.1]	4.75 [120.7]
					60-408-05	2.40 [60.9]	3.63 [92.2]
					60-408-07	1.91 [48.6]	3.14 [79.7]
					60-408-10	1.44 [36.5]	2.64 [67.2]
LCSF206/3	11.13 [282.6]	6.88 [174.6]	6.05 [153.6]	7.26 [184.4]	NONE	5.62 [142.7]	6.88 [174.6]
					60-408-05	4.50 [114.3]	5.74 [145.9]
					60-408-10	3.51 [89.1]	4.75 [120.6]
					60-408-15	2.52 [64.0]	3.76 [95.4]
					60-408-20	1.55 [39.4]	2.77 [70.3]

EXTENSION LEGS SHOWN ARE STANDARD WITH MACHINE.
 REFER TO MANUAL FOR OPTIONAL EXTENSION LEG SETS AND CLAMPING RANGES.
 DIMENSIONS IN BRACKETS ARE MILLIMETERS

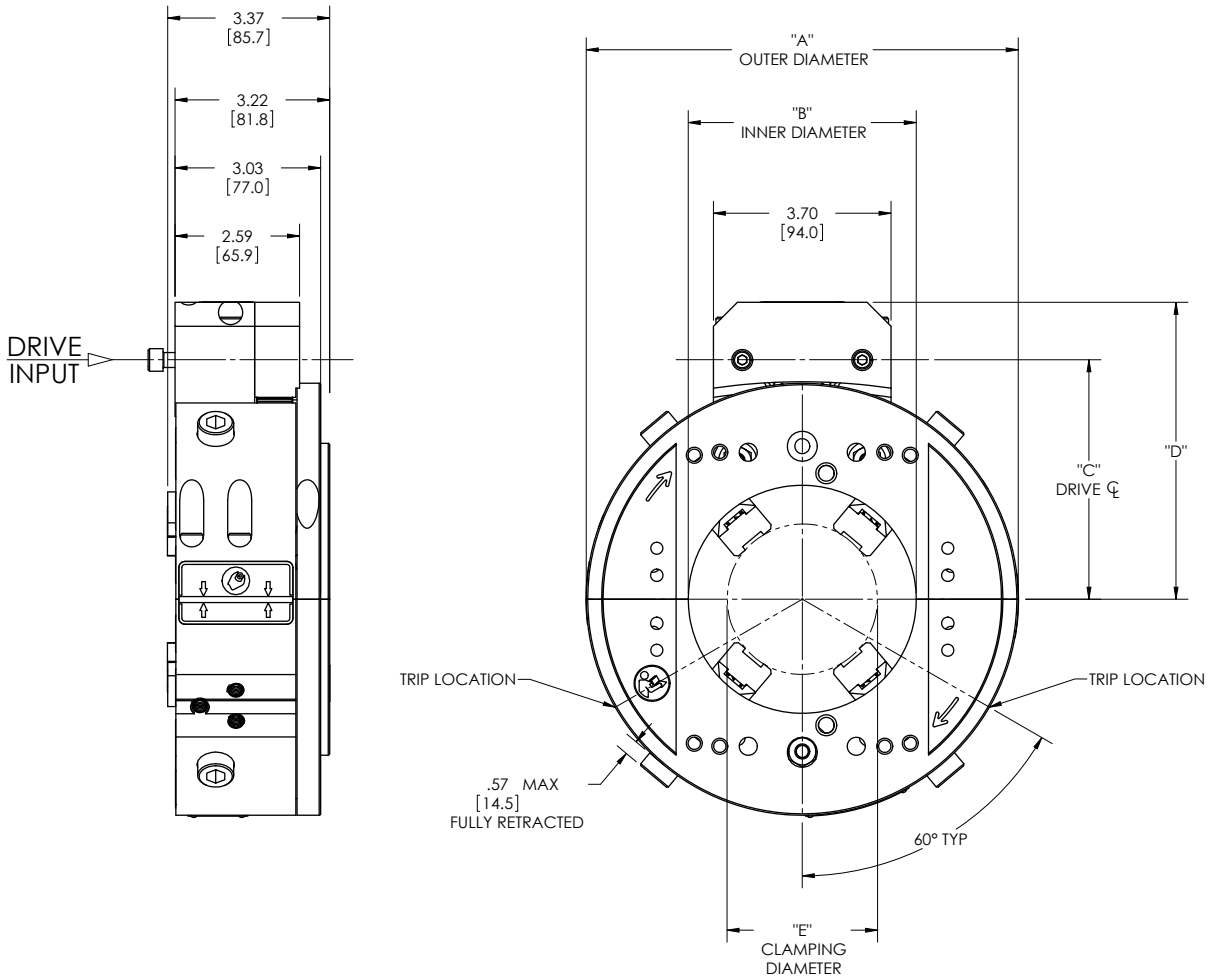

LCSF Models 408, 610, 612, and 814

-TABLE-								
MODEL	DIM. "A" OUTER DIAMETER	DIM. "B" INNER DIAMETER	DIM. "C" DRIVE \varnothing	DIM. "D"	EXTENSION LEG SET	DIM. "E" MIN. CLAMPING DIA.	DIM. "E" MAX. CLAMPING DIA.	DIM. "F" MAX. FULLY RETRACTED
LCSF408/3	13.13 [333.4]	8.88 [225.4]	7.05 [179.0]	8.26 [209.8]	NONE	7.16 [193.3]	8.88 [225.4]	.57 [14.5]
					60-408-10	5.49 [139.5]	6.74 [171.2]	
					60-408-20	3.51 [89.1]	4.75 [120.6]	
LCSF610/3	15.75 [400.1]	11.00 [279.4]	8.36 [212.3]	9.57 [243.1]	NONE	9.51 [241.6]	11.00 [279.4]	.68 [17.3]
					60-408-10	7.39 [187.8]	8.86 [225.0]	
					60-408-20	5.40 [137.2]	6.86 [174.4]	
LCSF612/3	17.75 [450.9]	13.00 [330.2]	9.36 [237.7]	10.57 [268.5]	NONE	11.51 [292.3]	13.00 [330.2]	.68 [17.3]
					60-408-10	9.39 [238.5]	10.86 [275.8]	
					60-408-20	7.39 [187.8]	8.86 [225.0]	
LCSF814/3	19.00 [482.6]	14.25 [362.0]	9.98 [253.6]	11.20 [284.4]	NONE	12.76 [324.0]	14.25 [362.0]	.68 [17.3]
					60-408-05	11.64 [295.6]	13.11 [332.9]	
					60-408-15	9.64 [244.8]	11.11 [282.1]	
					60-408-25	7.64 [194.1]	9.11 [231.4]	

EXTENSION LEGS SHOWN ARE STANDARD WITH MACHINE.
 REFER TO MANUAL FOR OPTIONAL EXTENSION LEG SETS AND CLAMPING RANGES.
 DIMENSIONS IN BRACKETS ARE MILLIMETERS

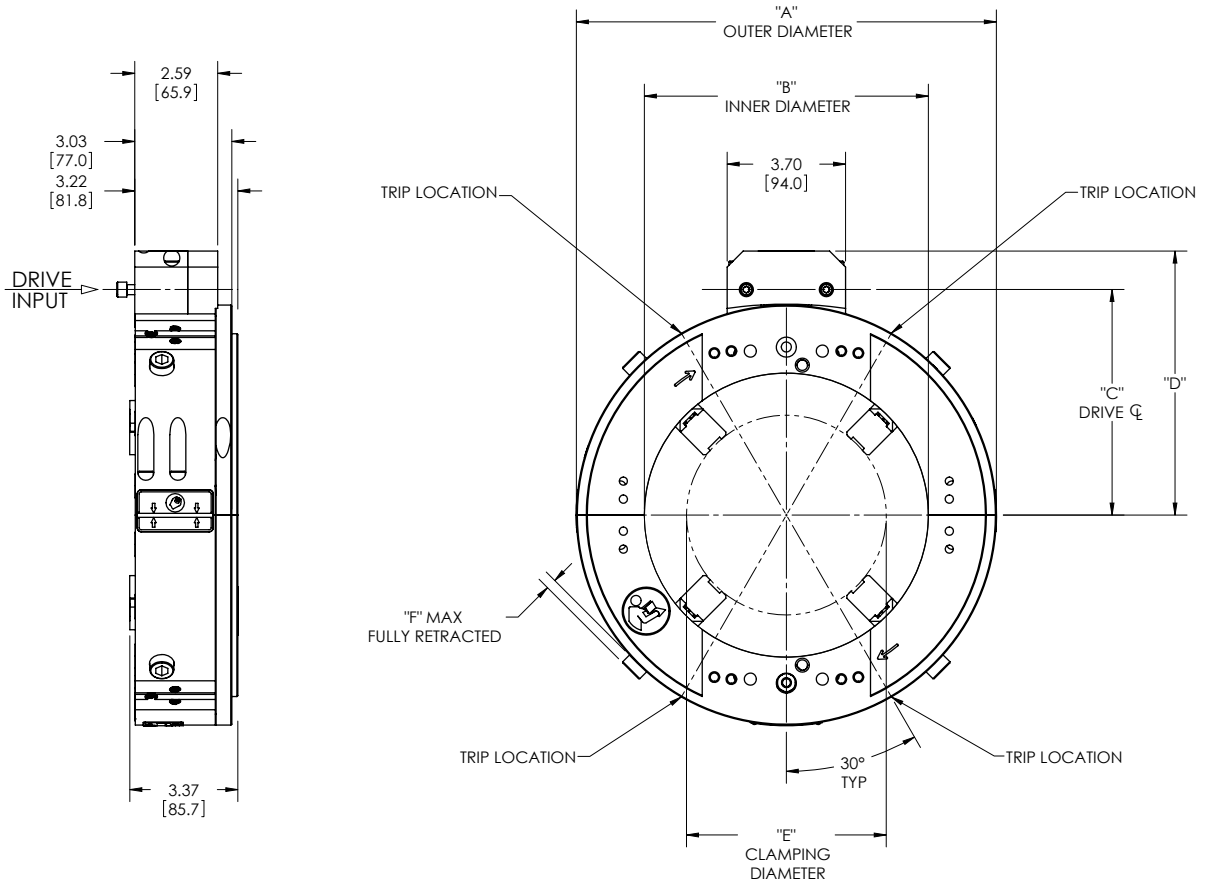

LCSF Models 1016 and 1420

-TABLE-							
MODEL	DIM. "A" OUTER DIAMETER	DIM. "B" INNER DIAMETER	DIM. "C" DRIVE \varnothing	DIM. "D"	EXTENSION LEG SET	DIM. "E" MIN. CLAMPING DIA.	DIM. "E" MAX. CLAMPING DIA.
LCSF1016/3	21.50 [546.1]	16.25 [412.8]	11.23 [285.3]	12.45 [316.1]	NONE	14.76 [374.8]	16.25 [412.8]
					60-408-10	12.64 [321.0]	14.11 [358.3]
					60-408-15	11.64 [295.6]	13.11 [332.9]
					60-408-25	9.64 [244.8]	11.11 [282.1]
LCSF1420/3	25.50 [647.7]	20.25 [514.4]	13.23 [336.1]	14.45 [366.9]	NONE	18.75 [476.4]	20.25 [514.4]
					60-408-10	16.63 [422.5]	18.10 [459.8]
					60-408-20	14.64 [371.7]	16.10 [409.0]
					60-408-30	12.64 [321.0]	14.11 [358.3]

EXTENSION LEGS SHOWN ARE STANDARD WITH MACHINE.
 REFER TO MANUAL FOR OPTIONAL EXTENSION LEG SETS AND CLAMPING RANGES.
 DIMENSIONS IN BRACKETS ARE MILLIMETERS

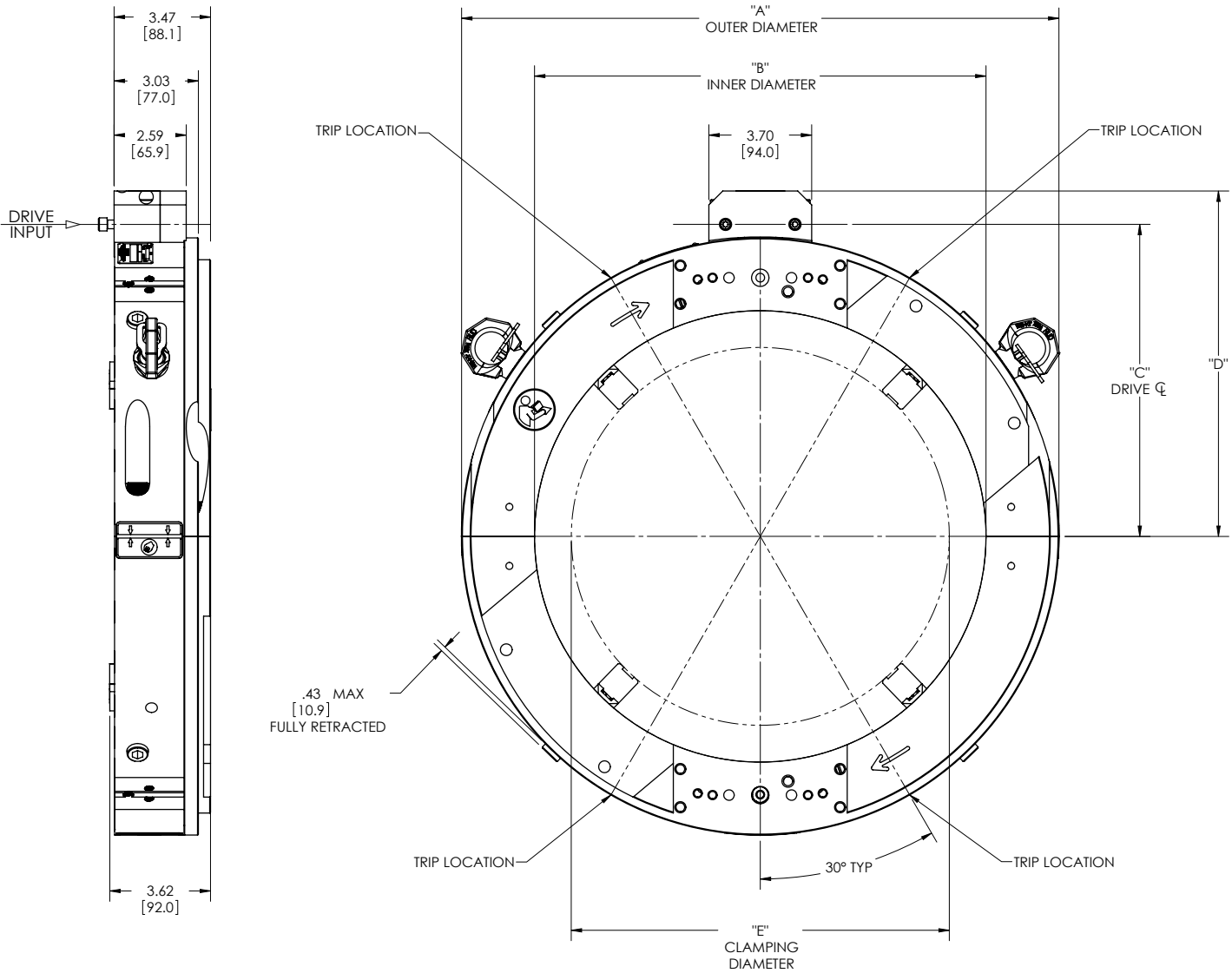

Low Clearance Parting Slide, 60-402-04

The low clearance parting slide is paired with the low clearance beveling slide (60-403-04). It is used with LCSF models 204-1420.

DIMENSIONS IN BRACKETS ARE MILLIMETERS.
 PIPE DIAMETER (DIM. "A") SHOWN WITHOUT CLEARANCE.
 WEIGHT = 2.8lb. [1.3kg]

-TABLE-		
MODEL	DIM. "A" DIAMETER	DIM. "B" RADIUS
LCSF204/3	4.76 [120.9]	4.50 [114.3]
LCSF206/3	6.88 [174.8]	5.53 [140.5]
LCSF208/3	8.88 [225.6]	6.53 [165.9]
LCSF210/3	11.00 [279.4]	7.84 [199.1]
LCSF612/3	13.00 [330.2]	8.83 [224.3]
LCSF814/3	14.25 [362.0]	9.46 [240.3]
LCSF1016/3	16.25 [412.8]	10.71 [272.0]
LCSF1420/3	20.25 [514.4]	12.70 [322.6]

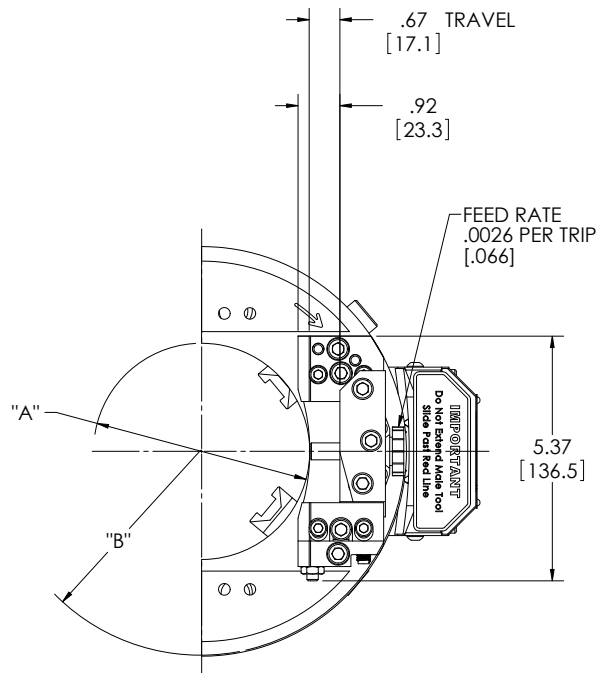
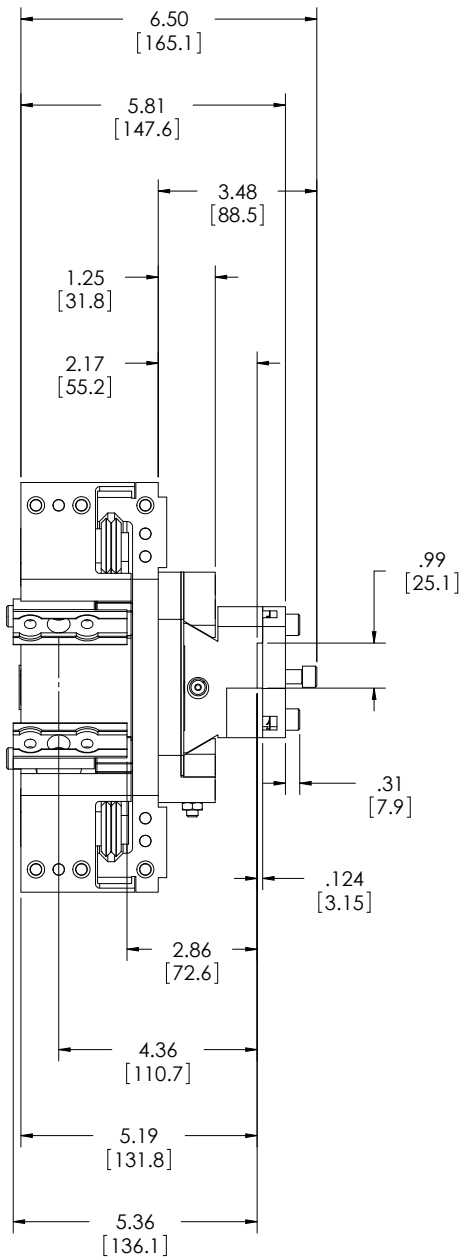

Slide travel and diameter/radius dimensions above are same for 60-402-04 parting slide and 60-403-04 beveling slide (next page).

Low Clearance Beveling Slide, 60-403-04

The low clearance beveling slide is paired with the low clearance parting slide (60-402-04). It is used with LCSF models 204-1420.

DIMENSIONS IN BRACKETS ARE MILLIMETERS.

WEIGHT = 2.8lb. [1.3kg]

See 60-402-04 parting slide drawing on previous page for slide travel and diameter/radius dimensions.

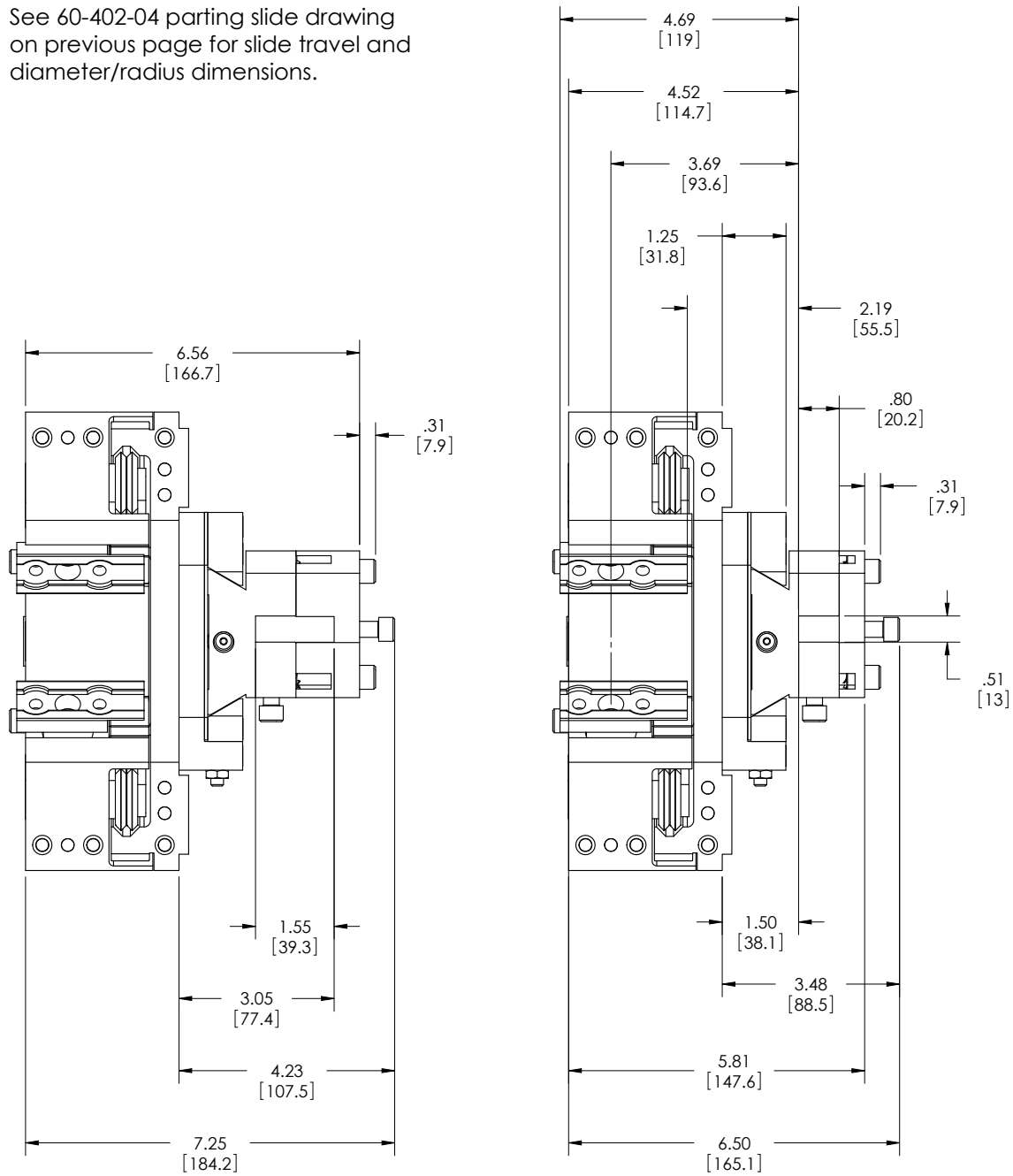

With double bevel tool cover

With standard tool cover

Extended Parting Slide, 60-415-00

The extended parting slide is paired with the extended beveling slide (60-416-00). It is used with all LCSF models.

DIMENSIONS IN BRACKETS ARE MILLIMETERS.
PIPE DIAMETER (DIM. "A") SHOWN WITHOUT CLEARANCE.
WEIGHT = 7.5lb. [3.4kg]

-TABLE-			
MODEL	POSITION	DIM. "A" DIAMETER	DIM. "B" RADIUS
LCSF 204/3	LOW	.76 [19.2]	4.47 [113.5]
	MID	2.76 [70.0]	5.46 [138.7]
	HIGH	4.76 [120.8]	6.46 [164.1]
LCSF 206/3	LOW	2.88 [73.2]	5.53 [140.5]
	MID	4.88 [124.0]	6.53 [165.8]
	HIGH	6.88 [174.8]	7.52 [191.1]
LCSF 408/3	LOW	4.96 [126.0]	6.53 [165.8]
	MID	6.90 [175.2]	7.52 [191.1]
	HIGH	8.83 [224.4]	8.52 [216.4]
LCSF 610/3	LOW	7.50 [190.5]	7.84 [199.0]
	MID	9.43 [239.6]	8.83 [224.4]
	HIGH	11.00 [279.4]	9.83 [249.7]
LCSF 612/3	LOW	9.43 [239.6]	8.83 [224.4]
	MID	11.37 [288.7]	9.83 [249.7]
	HIGH	13.00 [330.2]	10.83 [275.1]
LCSF 814/3	LOW	10.64 [270.3]	9.46 [240.2]
	MID	12.58 [319.4]	10.46 [265.6]
	HIGH	14.25 [362.0]	11.45 [290.9]
LCSF 1016/3	LOW	13.06 [331.7]	10.71 [271.9]
	MID	14.99 [380.8]	11.70 [297.3]
	HIGH	16.25 [412.8]	12.70 [322.7]
LCSF 1420/3	LOW	14.83 [429.9]	12.70 [322.7]
	MID	18.86 [479.0]	13.70 [348.0]
	HIGH	20.25 [514.4]	14.70 [373.4]

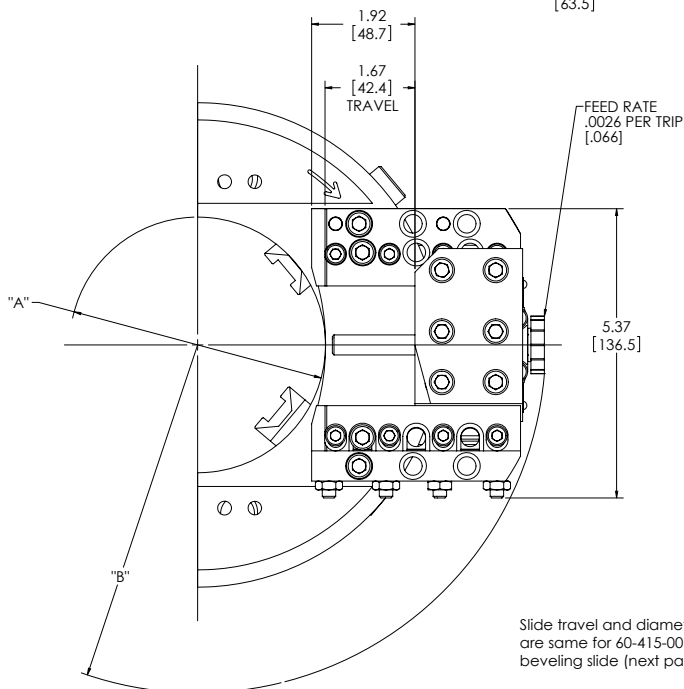
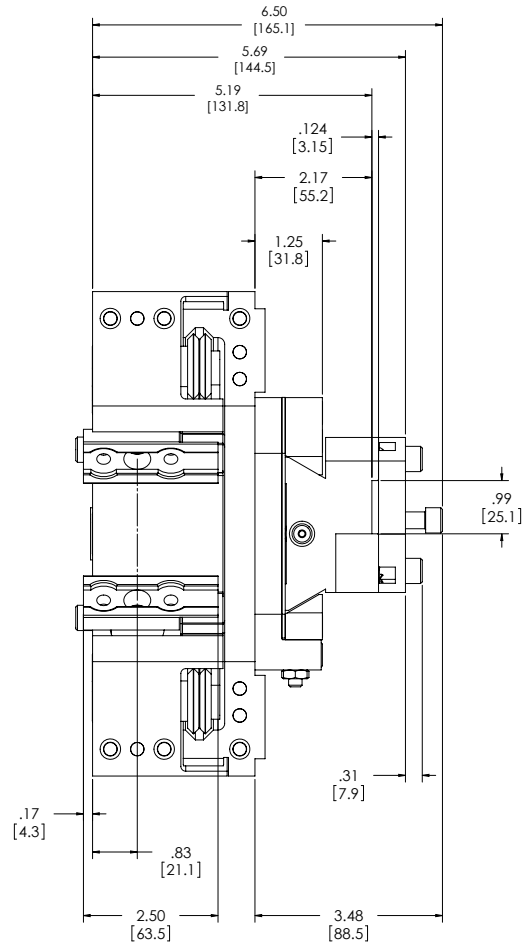

Slide travel and diameter/radius dimensions above are same for 60-415-00 parting slide and 60-416-00 beveling slide (next page).

Extended Parting Slide, 60-416-00

The extended beveling slide is paired with the extended parting slide (60-415-00). It is used with all LCSF models.

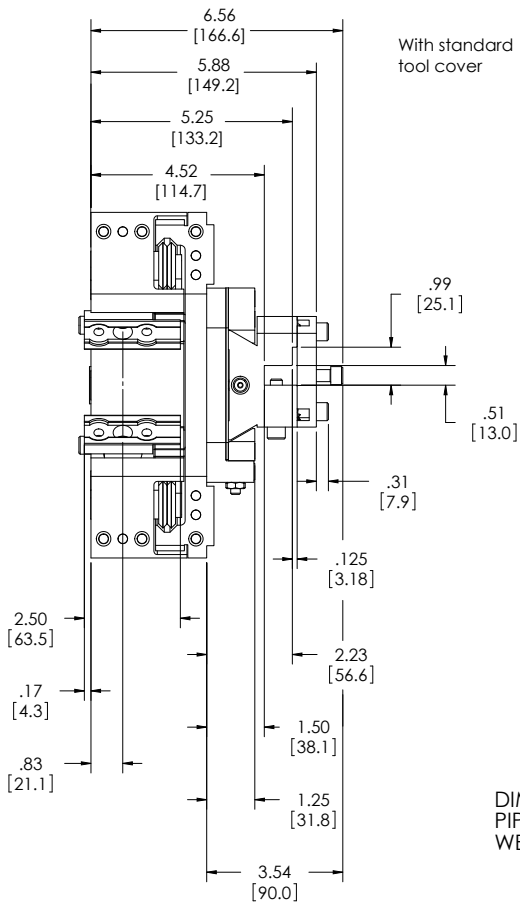
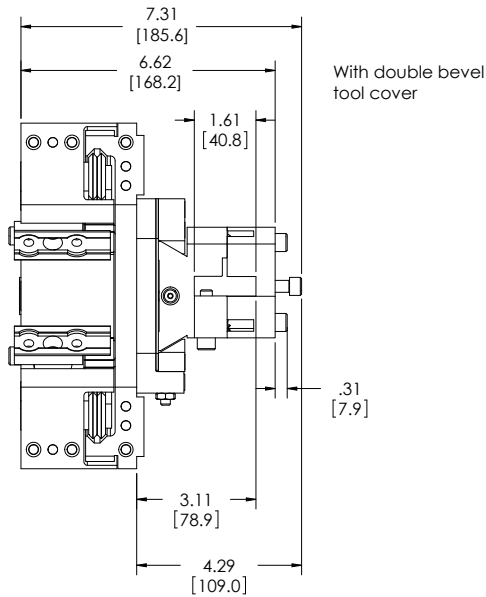

-TABLE-			
MODEL	POSITION	DIM. "A" DIAMETER	DIM. "B" RADIUS
LCSF 204/3	LOW	.76 [19.2]	4.47 [113.5]
	MID	2.76 [70.0]	5.46 [138.7]
	HIGH	4.76 [120.8]	6.46 [164.1]
LCSF 206/3	LOW	2.88 [73.2]	5.53 [140.5]
	MID	4.88 [124.0]	6.53 [165.8]
	HIGH	6.88 [174.8]	7.52 [191.1]
LCSF 408/3	LOW	4.96 [126.0]	6.53 [165.8]
	MID	6.90 [175.2]	7.52 [191.1]
	HIGH	8.83 [224.4]	8.52 [216.4]
LCSF 610/3	LOW	7.50 [190.5]	7.84 [199.0]
	MID	9.43 [239.6]	8.83 [224.4]
	HIGH	11.00 [279.4]	9.83 [249.7]
LCSF 612/3	LOW	9.43 [239.6]	8.83 [224.4]
	MID	11.37 [288.7]	9.83 [249.7]
	HIGH	13.00 [330.2]	10.83 [275.1]
LCSF 814/3	LOW	10.64 [270.3]	9.46 [240.2]
	MID	12.58 [319.4]	10.46 [265.6]
	HIGH	14.25 [362.0]	11.45 [290.9]
LCSF 1016/3	LOW	13.06 [331.7]	10.71 [271.9]
	MID	14.99 [380.8]	11.70 [297.3]
	HIGH	16.25 [412.8]	12.70 [322.7]
LCSF 1420/3	LOW	16.93 [429.9]	12.70 [322.7]
	MID	18.86 [479.0]	13.70 [348.0]
	HIGH	20.25 [514.4]	14.70 [373.4]

See 60-415-00 parting slide drawing on previous page for slide travel and diameter/radius dimensions.

DIMENSIONS IN BRACKETS ARE MILLIMETERS.
PIPE DIAMETER (DIM. "A") SHOWN WITHOUT CLEARANCE.
WEIGHT = 7.5lb. [3.4 kg]

Universal Counterbore Slide, 60-405-UC

The universal counterbore slide is used with all LCSF models.

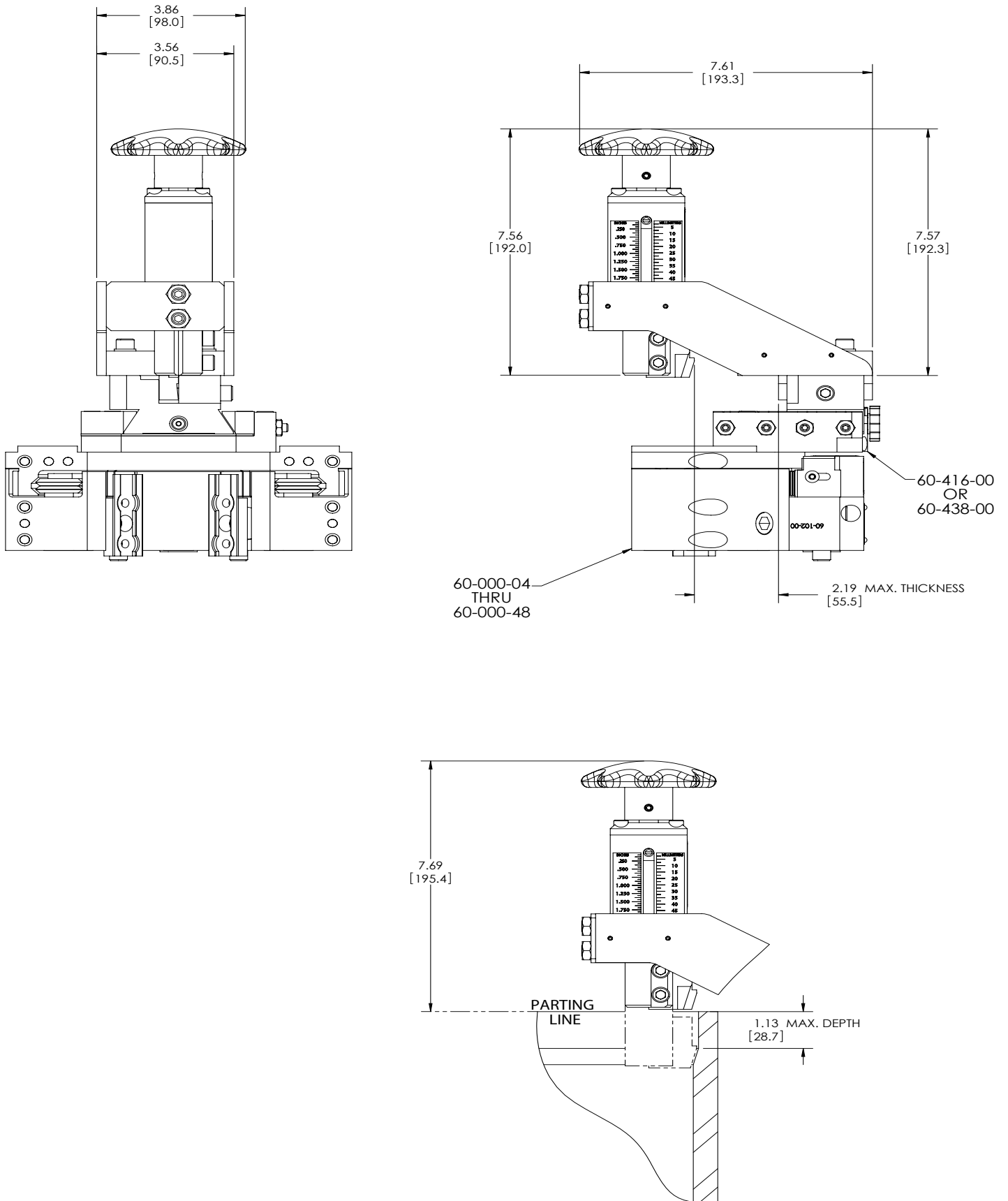

Front Drive Pinion Assembly, 60-425-03

-TABLE-	
MODEL	DIM. "A"
LCSF204/3	9.44 [239.8]
LCSF206/3	10.50 [266.7]
LCSF408/3	11.50 [292.1]
LCSF610/3	12.81 [325.5]
LCSF612/3	13.81 [350.9]
LCSF814/3	14.44 [366.7]
LCSF1016/3	15.69 [398.5]
LCSF1420/3	17.69 [449.3]

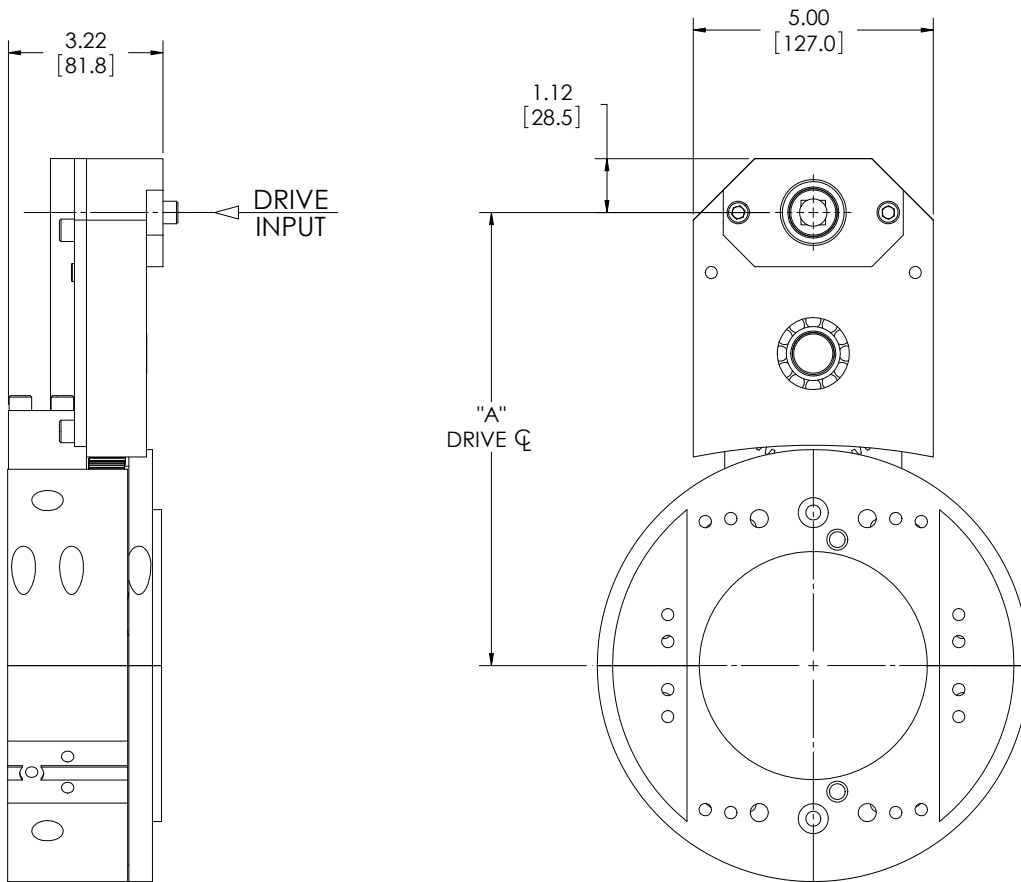

DIMENSIONS IN BRACKETS ARE MILLIMETERS.
WEIGHT = 8lb. [4kg]

1.5 HP Right-Angle Air Drive, 60-423-00

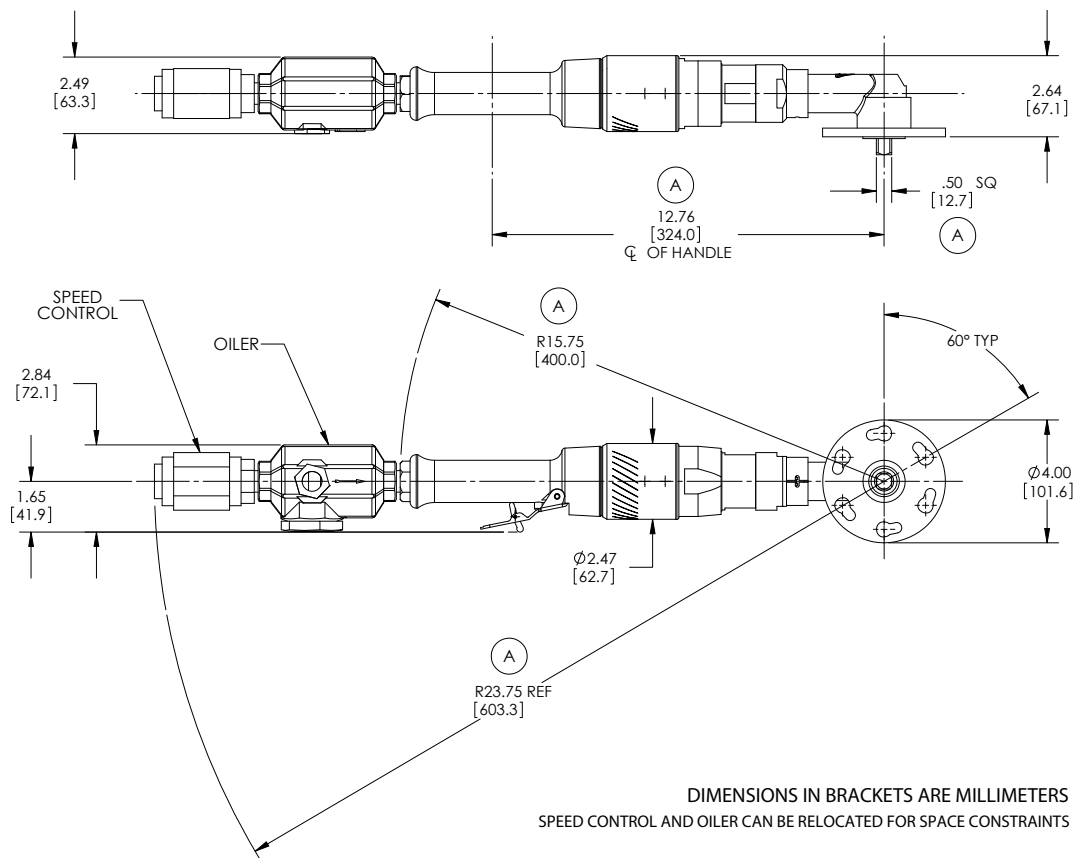

2.5 HP Right-Angle Air Drive, 60-423-01

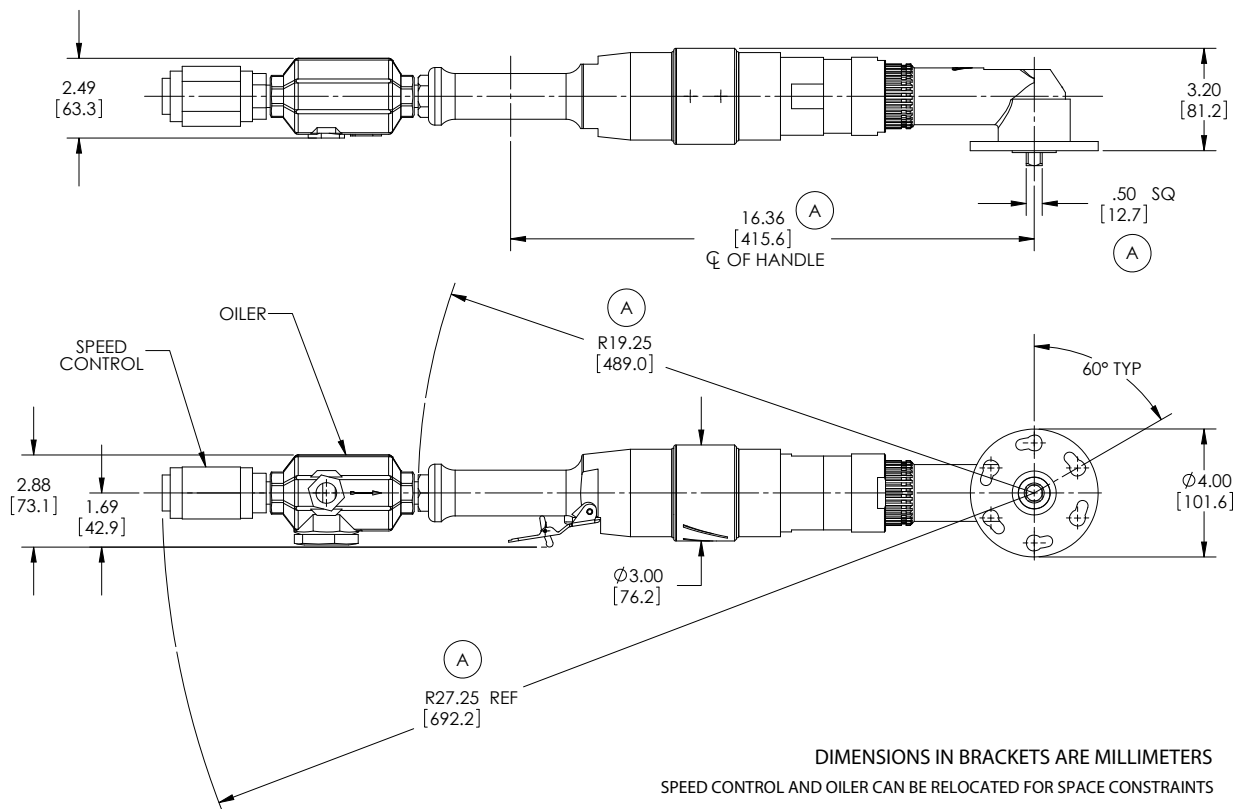

2.5 HP Right-Angle Reversible Air Drive, 60-4010-01

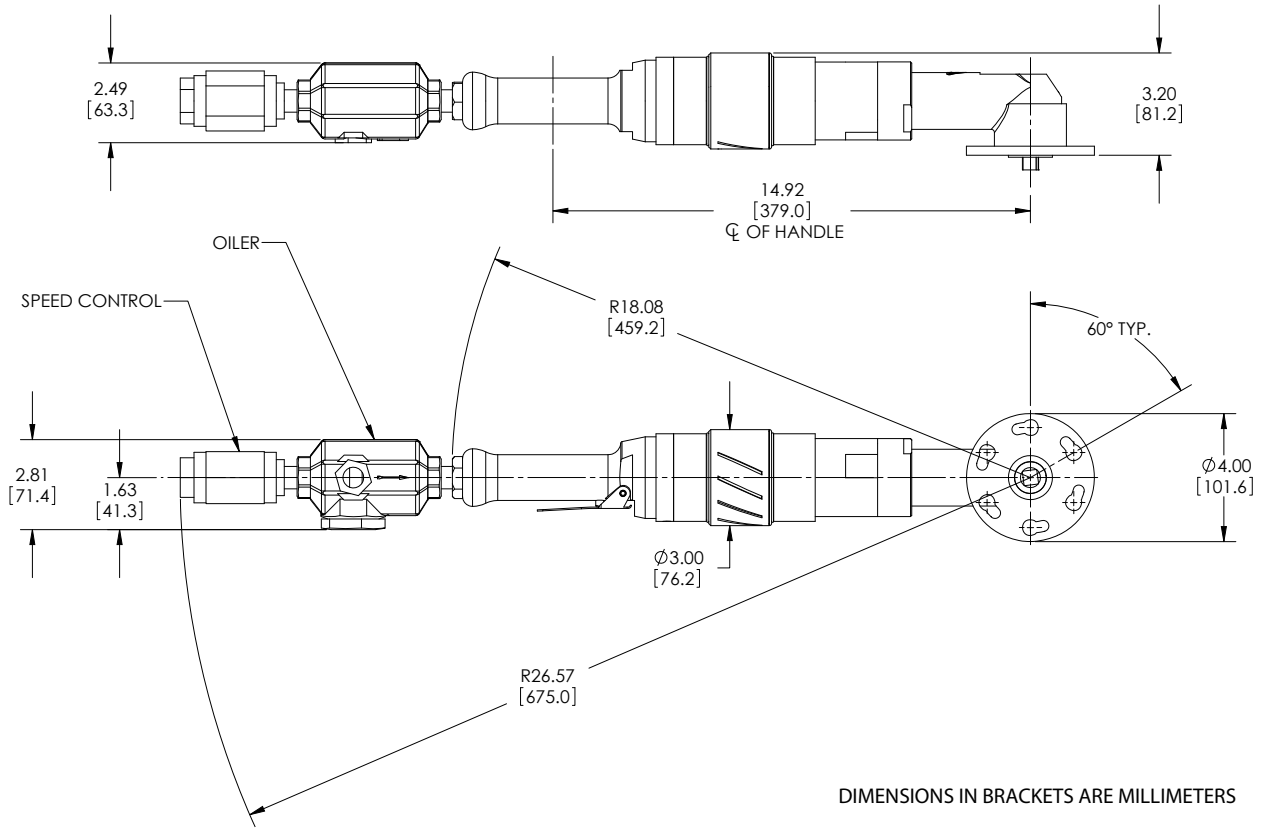

Hydraulic Drive, 60-424-02

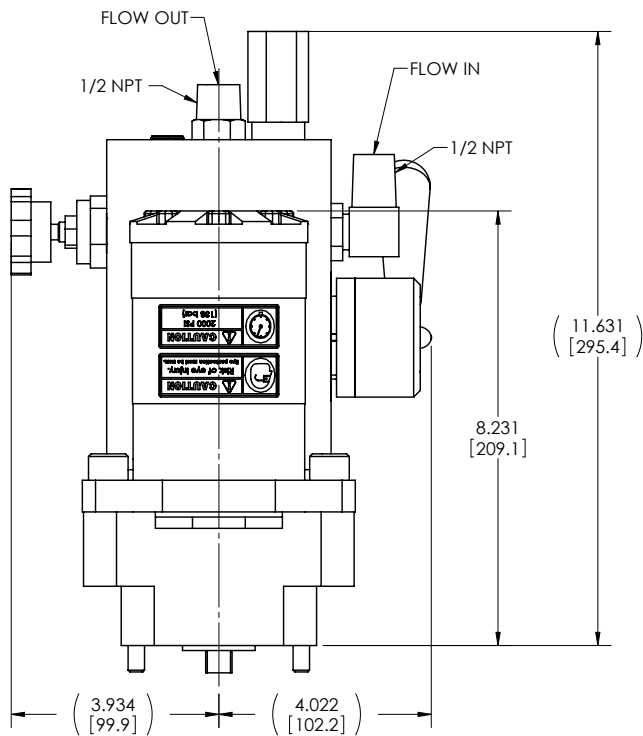

WEIGHT: 25.4 lbs [11.5 kg]
 MUST ATTACH MOTOR MOUNT TO PINION HOUSING
 PRIOR TO MOUNTING HYDRAULIC MOTOR.
 MAXIMUM FLOW: 15 GPM [57 LPM]
 PRESSURE: UP TO 2000 PSI [138 BAR]

PERFORMANCE DATA	
FLOW GPM [LPM]	RPM
2 [7.6]	47
4 [15.1]	94
6 [22.7]	141
8 [30.3]	188
10 [37.9]	235
12 [45.4]	282
14 [53.0]	330
15 [56.8]	353

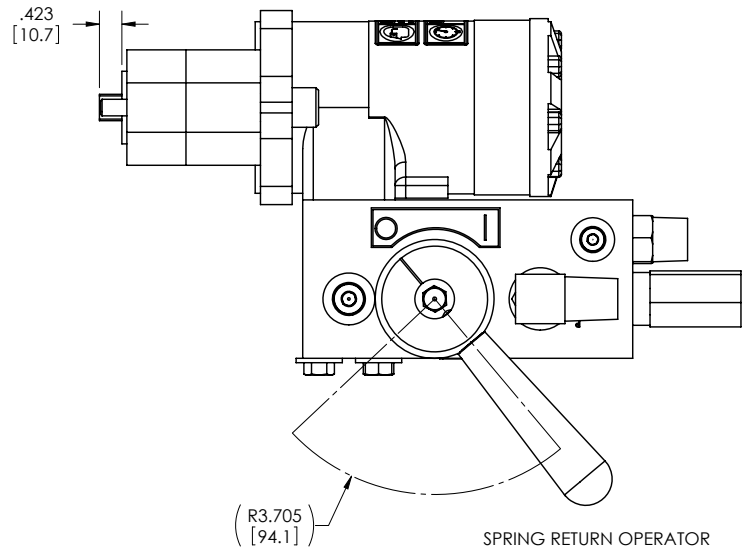
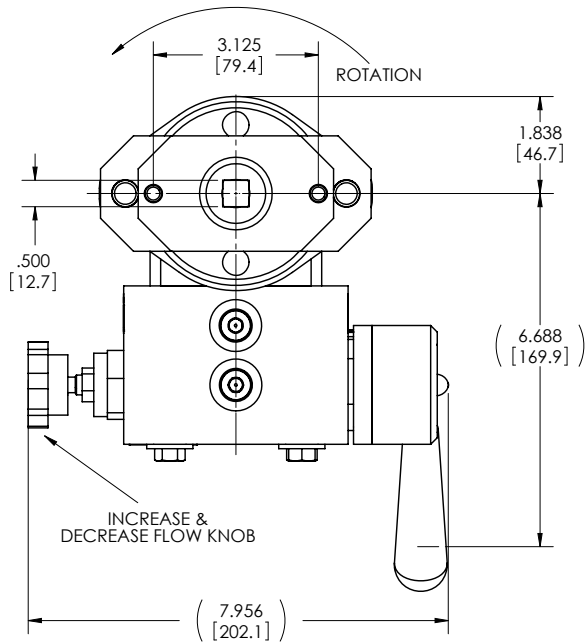

Chapter 4

Assembly, Disassembly, and Storage

MACHINE DISASSEMBLY FOR STORAGE

These instructions assume the LCSF machine has been disconnected from the power source and removed from the workpiece, as described in Chapter 5.

1. Remove the drive assembly (pneumatic or hydraulic) from the LCSF.
2. Retract the tool slides. It is not necessary to remove the standard tool slides to store the machine.
3. Clean the machine of debris such as metal chips and excess coolant.
4. Split the machine halves and examine the bearing raceway for metal chips.

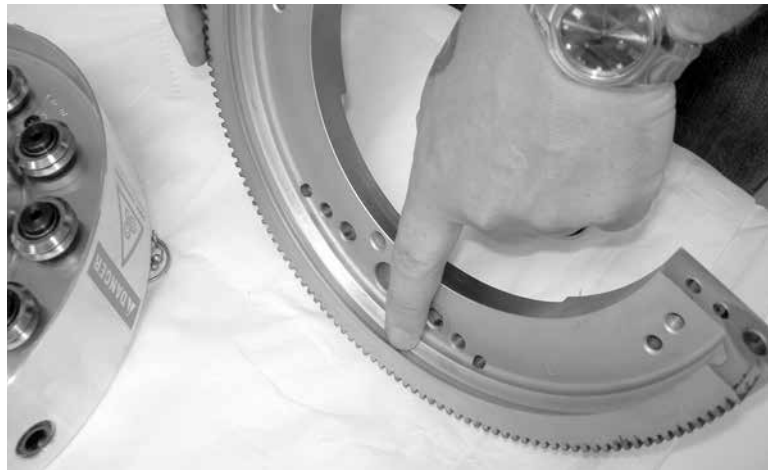

Figure 4-1. Check the bearing raceway for chips and clean it if necessary.

5. Apply two drops of Wachs way oil (60-1184-00) to the felt wiper before storing the machine.

STORAGE/SHIPPING CASES

All LCSF models 204 through 1420 are stored and shipped in custom cases made of heavy-duty molded plastic. The case contains a formed foam insert that securely holds the LCSF machine, slides, tools, drive motor, and accessories.

Models 204, 206, and 408 are stored with the machine assembled as a ring, as shown in Figure 4-2.



Figure 4-2. The photo shows the model 206 LCSF stored in its case.

The larger models are split into halves for storage. Figure 4-3 shows the case layout for models 610, 612, and 814. Figure 4-4 shows the case layout for models 1016 and 1420. The machines are stored with the slides and trip assembly attached.

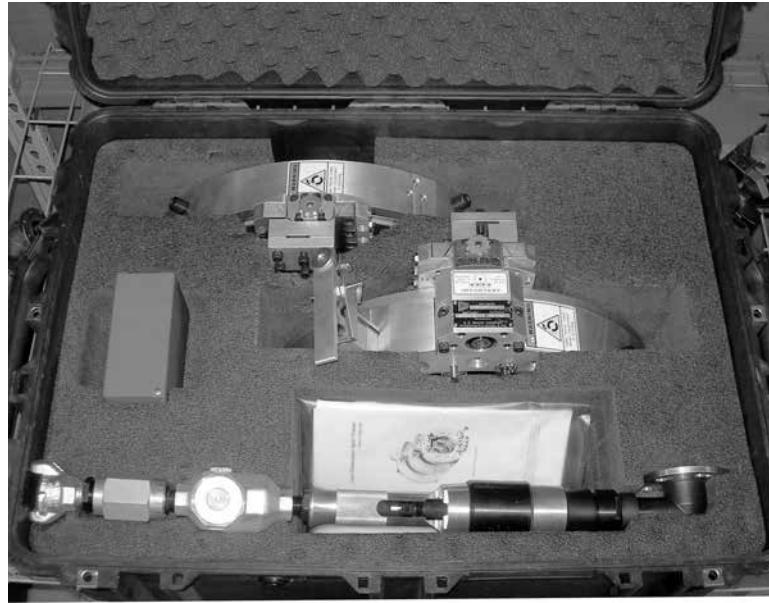

Figure 4-3. The photo shows a model 814 LCSF stored in its case.

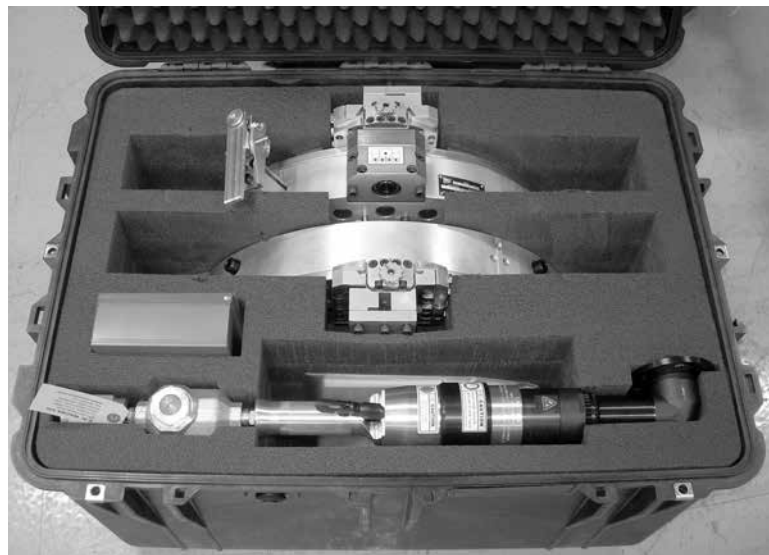

Figure 4-4. The photo shows the model 1016 LCSF in its case.

STORAGE GUIDELINES

- Clean the machine by wiping off dirt, debris, and accumulated oil or grease.
- Put oil in the air motor oiler, and operate the motor for a few seconds to lubricate its internal components.
- Lubricate the machine according to the instructions in Chapter 6.
- Spray or wipe a light coating of anti-corrosion lubricant on non-finished, non-painted surfaces.
- Put the machine in its storage case, with all components stored in their compartments.
- If possible, keep the storage case indoors and away from moisture.

Chapter 5

Operating Instructions

PLANNING THE OPERATION

It is important to begin each project by visually inspecting the worksite. Important information can be gathered at this time to aid in the setup of the machine tool. The following items should be considered when doing this review:

- Work space constraints
- Proper scaffolding to support equipment and workers
- Machine operating clearances
- Power requirements to run equipment
- Containment of cutting debris /coolant during the operation

In order to perform machine set-up, be sure to take the following measurements:

- Radial clearance around the pipe.
- Axial clearances end to end.
- Verify the pipe schedule / size.

This information will help to determine if clamp pads will be required, what tool slides will be needed to perform the operation, and what tooling is necessary to complete the cut.

See the drawings at the end of Chapter 3 for machine dimensions of all LCSF models. The dimensions in the drawings will allow you to plan how to install the machine for the operating environment.



Figure 5-1. Measure the radial clearance around the pipe surface.



Figure 5-2. Measure the axial clearance along the planned work area on the pipe.

Verify the actual diameter of the pipe. If you cannot measure the diameter directly (for instance, an in-line pipe with no open end), measure the circumference and divide by 3.14 (pi).

Example:

$$40.0'' \text{ circumference} / 3.14 = 12.74'' \text{ diameter}$$



Figure 5-3. Verify the pipe circumference by measuring.

Tool Selection

This section describes the features of each type of tooling, and explains the factors to consider when selecting specific tools for a given application.

When selecting tooling, you will typically want to use the shortest tool that will accomplish the operation you're performing. A shorter effective tool length (the distance between the tool holder and the cutting surface) increases rigidity, reducing vibration or chatter during cutting. Factors that affect the required tool length are the following:

- The difference in size between the LCSF machine and the pipe. Cutting performance is usually best with the smallest LCSF that will fit on the pipe.
- The mounting position of the slide on the LCSF (for slides with multiple positions). The slide should be as close as possible to the pipe O.D.
- The thickness of the pipe wall. A longer tool is required for heavy-wall pipe, to reach the I.D. (Cutting heavy-wall pipe makes using the correct LCSF size and slide position even more important.)

It is possible to reduce the effective tool length of a longer tool by mounting it farther back in the tool holder, so that it extends behind the slide. However, this is not recommended for safety reasons. Having tools extend beyond the diameter of the machine is hazardous to the operator.

Refer to the tooling tables in Chapter 9 and operating envelope drawings in Chapter 3.

Parting-Only Operation

For a parting (straight cut-off) operation, you will use 2 identical parting tools, one in the parting slide and one in the beveling slide. The tool holders are designed with a parting offset, so the tools cut a wider groove than the thickness of each tool. This prevents the tools from jamming in the groove and breaking off, or stalling the machine.

NOTE

Standard LCSF beveling slides are also referred to as “parting/beveling slides”, since the beveling tool holder is designed so that it can hold a parting tool instead. (Parting slide tool holders can only hold parting tools.)

Standard parting blades are 3/16” thick, and are available in a variety of lengths. You can use solid high speed steel blades, or insert holders with carbide inserts. For heavier wall applications, 1/4” tools are available. See the tooling tables in Chapter 9 for available parting tools.

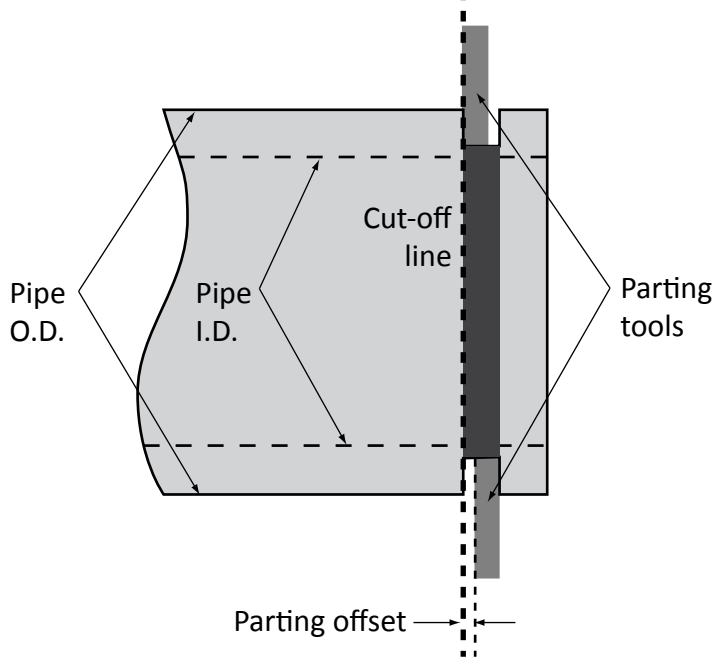

Figure 5-4. The drawing illustrates the parting operation, with two offset parting tools. The parting offset distance is built into the parting and parting/beveling tool holders.

Parting/O.D. Beveling Operation

For a parting/beveling operation, you will use a parting tool in the parting slide, and a beveling tool with the desired bevel angle in the beveling slide.

Beveling tools are made with the desired form (angle) built into the cutting edge of the tool. The tool feeds radially into the end of the pipe. This method is used mainly for thin wall pipe up to 1 inch. For heavier-wall pipe, single-point beveling is typically required; see “Single-Point Beveling” below.

Standard beveling tools are available with single angles or compound angles.

- 30° single angle
- 37.5° single angle
- 10° x 37.5° compound angle
- 10° x 30° compound angle

Form tool beveling is fast on thinner wall pipe, and is easier to set up than single-point. However, it can have the following disadvantages:

- there are a limited number of designs unless tools are specially made
- it requires cutting fluid to extend tool life
- it has limitations on heavy wall pipe; the maximum wall thickness that can be form tool beveled with a 10° x 37.5° form tool is 1-1/4 inch
- it machines a larger surface area, thus requiring a slower r.p.m. and maximum horsepower.

See the tooling tables in Chapter 9 for available beveling tools.

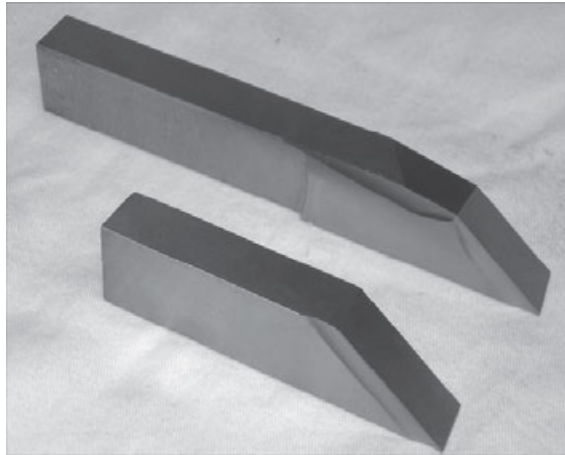

Figure 5-5. Standard form Tools: 10° x 37.5° Compound Angle (top), and 37.5° Single Angle (bottom)

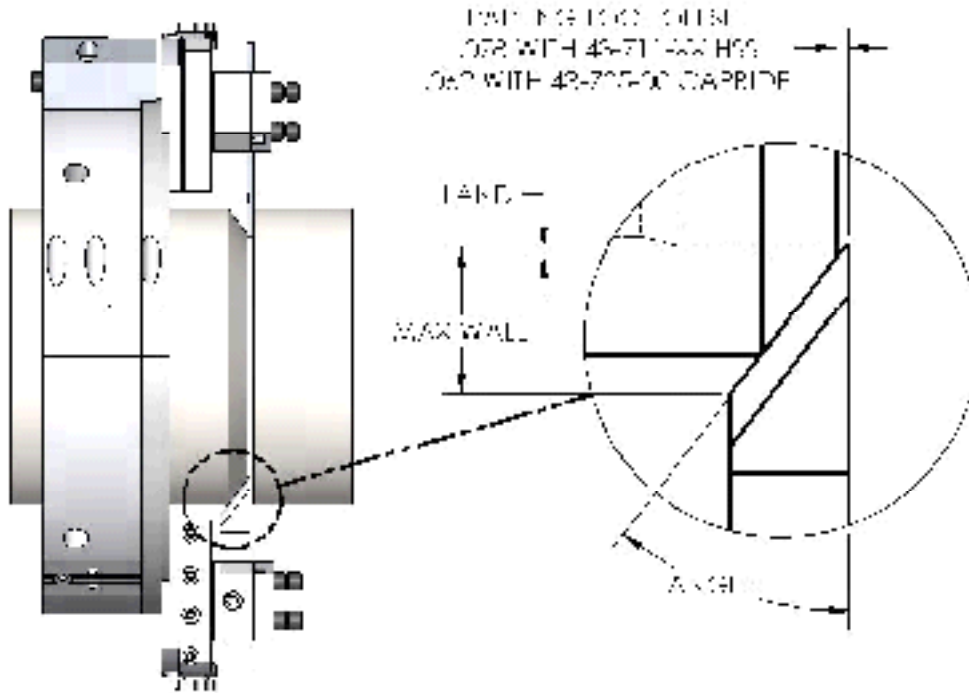

Figure 5-6. The drawing illustrates the parting/beveling operation.

O.D. Beveling-Only Operation

If you are only beveling a pipe end that has already been cut off, use a beveling tool in the parting/beveling slide. Leave the parting tool slide empty.

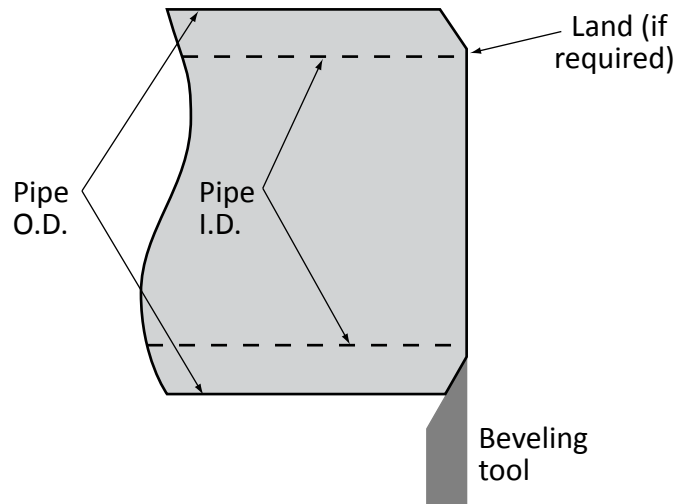

Figure 5-7. The drawing illustrates the O.D. bevel operation.

Single-Point Beveling

Single-point beveling is performed on thick-walled pipes, where the cutting surface is too wide for a form tool to work effectively. Only the tip of the tool cuts; the tool feed is in two dimensions to follow the profile of the desired bevel.

Single-point beveling with the LCSF is performed using the bridge slide accessory, with a standard single-point tool holder and insert. See the *Bridge Slide Accessory for Low-Clearance Split Frame User's Manual* for instructions on beveling with the bridge slide.

Operating Envelopes

The drawings at the end of Chapter 3 illustrate the operating envelope for the available combinations of LCSF machines and tool slides.

In the table on each drawing, find the row for your LCSF model. The **DIM "A" DIAMETER** column indicates the maximum pipe diameter for the given LCSF machine and slide combination. (Note that the maximum pipe diameter is sometimes a little more than the nominal LCSF size.) Where multiple slide mounting positions are available, there is a separate row with dimensions for each position.

Low Clearance Slides (60-402-04/60-403-04)

Parting slide 60-402-04 and beveling slide 60-403-04 can be used with all LCSF models from LCSF 204 (4 inch) to LCSF 1420 (20 inch).

These slides have a single installation position on the LCSF.

Extended “Standard” Slides (60-415-00/60-416-00)

Parting slide 60-415-00 and beveling slide 60-416-00 are the standard slides for LCSF models 204 (4 inch) through 1420 (20 inch). The drawings and tables in Chapter 3 illustrate the operating envelopes for all slides.

These slides have three installation positions on the LCSF, indicated in the tables as **LOW**, **MEDIUM**, and **HIGH**. Choose the lowest slide position that will not collide with the pipe surface. This minimizes the extended length of the tool, increasing rigidity of the cutting system.

Setting the position is described in the section “Install Tool Slides and Tooling”, later in this chapter.

LIFTING AND RIGGING THE LCSF

Smaller LCSF models can be handled safely by one person. Depending on configuration, some components are heavy enough to require 2 operators or a lifting device. See the weight charts in Chapter 2.



WARNING

See weight charts in Chapter 2 for weights of the LCSF models. One person should not lift a machine or component over 40 lb (18 kg). Two people should not lift a machine or component over 80 lb (36 kg). Use a crane or other lifting device to lift heavy components.

Models with Lift Eyebolts

LCSF models 610 and larger have 4 threaded holes (2 on each half of the stationary ring) for lifting eyebolts. Two lift eyebolts are provided with the machine.

To lift the entire machine (assembled ring), install the lift eyes in two adjacent threaded holes.



NOTE

The photos in this section use a 24" LCSF (model 1824) as an example. The instructions are identical for all LCSFs that have lift eyebolts.

To lift one half of the machine (separated ring), install the lift eyebolts in both holes of the half you are lifting.

- Do not lift the ring half using only one lift eye.
- Make sure the alignment pin is installed through the rotating and stationary ring.

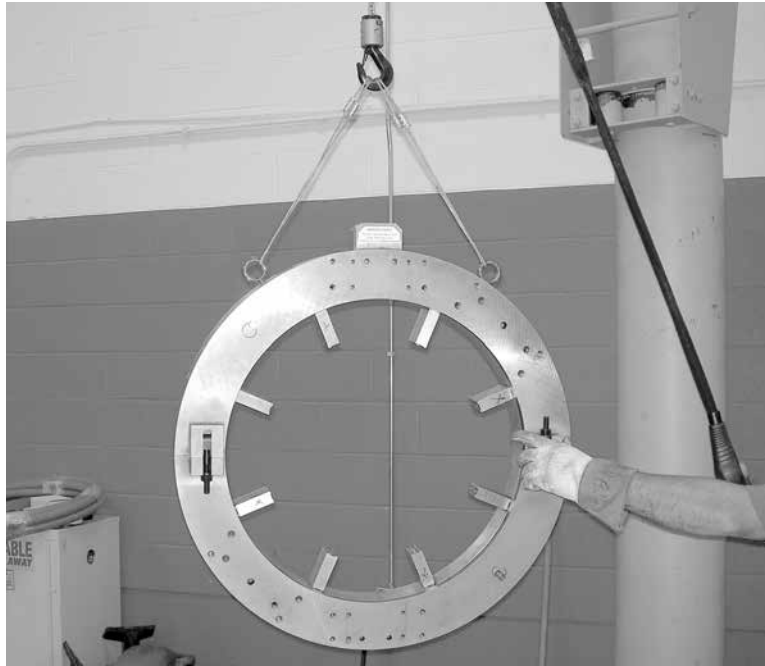

Figure 5-8. Lift the assembled machine as shown.

- 1.** Lift one half of the machine out of the case.

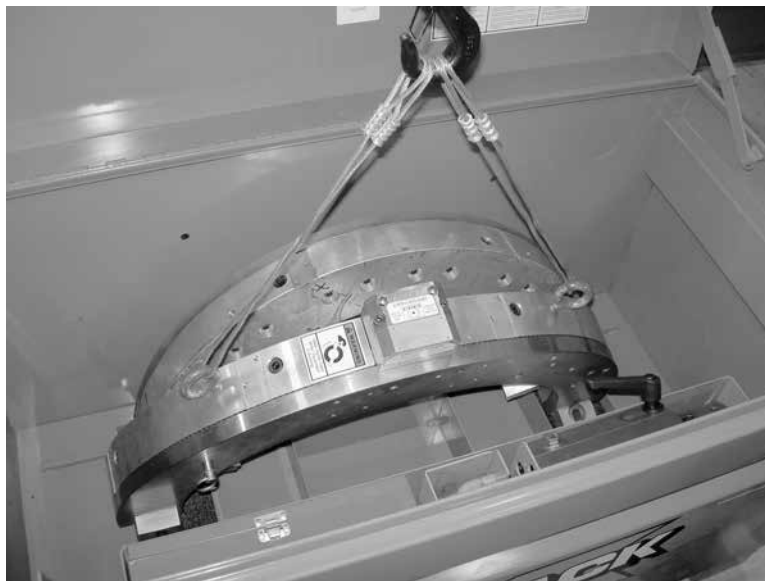

Figure 5-9. Use a lifting device to lift each half of the machine out of the storage case.

- 2.** Lay the ring half on the floor or a suitable work surface.

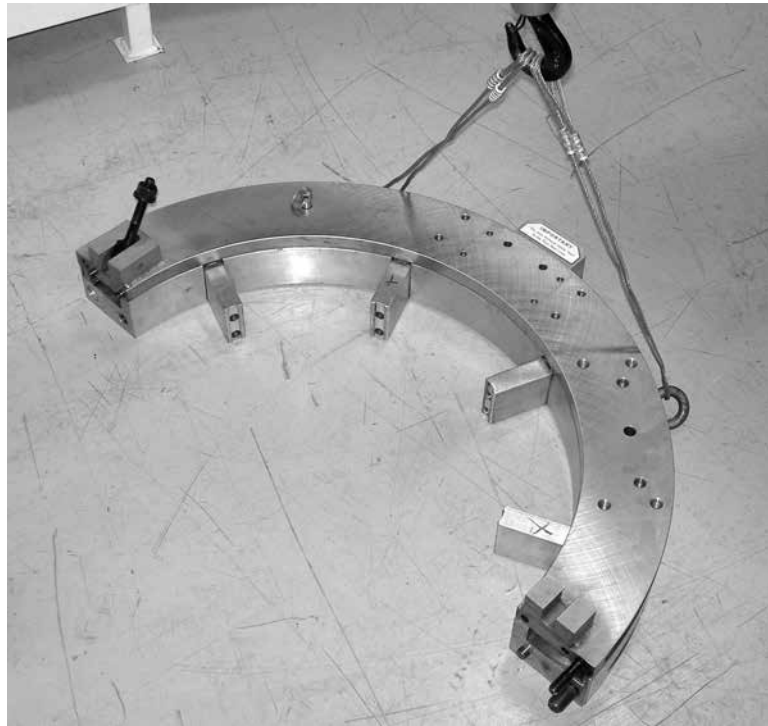

Figure 5-10. Lay the ring half on the work surface.

- 3.** Assemble the halves of the ring.

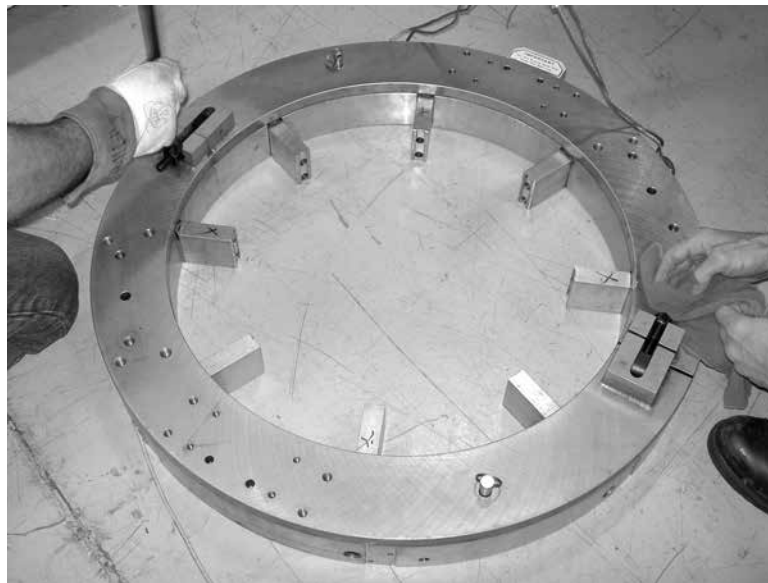

Figure 5-11. Assemble the machine on the floor for use on an open-ended pipe.

- 4.** To install the machine on an inline pipe, use a lift bar to pick up the machine as shown.



Figure 5-12. Assemble the ring halves around the pipe as shown.

- 5.** Push the machine halves together and tighten the screws.

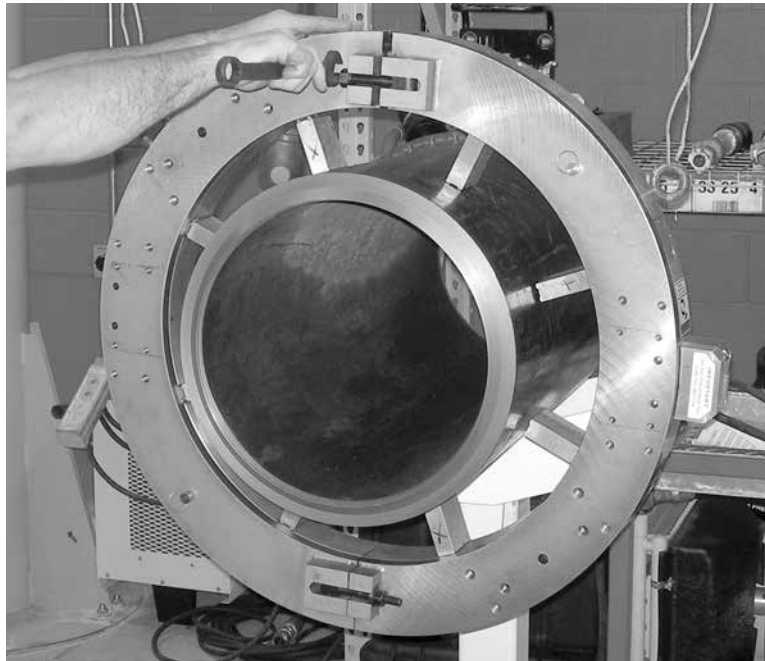

Figure 5-13. Assemble the halves of the machine around the pipe.

SETTING UP THE LCSF

Clamp Leg Set-Up

1. Measure the O.D. of the pipe to be machined. (If necessary, measure the circumference and divide by 3.14 to get the diameter.)
2. In the Clamp Pad Extension Charts on the following pages, find the column for your LCSF model.
3. Find the MAX/MIN range that includes the diameter you measured in Step 1. Select the corresponding leg set in the table row. All legs have their part numbers and size range stamped on them.

Example: You have a model 206 LCSF, and the pipe O.D. is 5.5 inches. You need to use the 1/2" leg extension set, 60-408-05.



NOTE

If your pipe O.D. is within the MAX/MIN range of 2 leg sets, it is generally better to select the longer legs. However, shorter legs may be an advantage if the pipe is out of round or if the work environment has limited clearance for mounting the LCSF.

4. Install the 4 legs in the set onto the clamp pads of the LCSF. The legs have captivated screws. Tighten the screws securely.
5. Make sure the legs are fully retracted by turning the clamping screws counter-clockwise until they stop. The clamp screws require a 3/8" hex wrench.

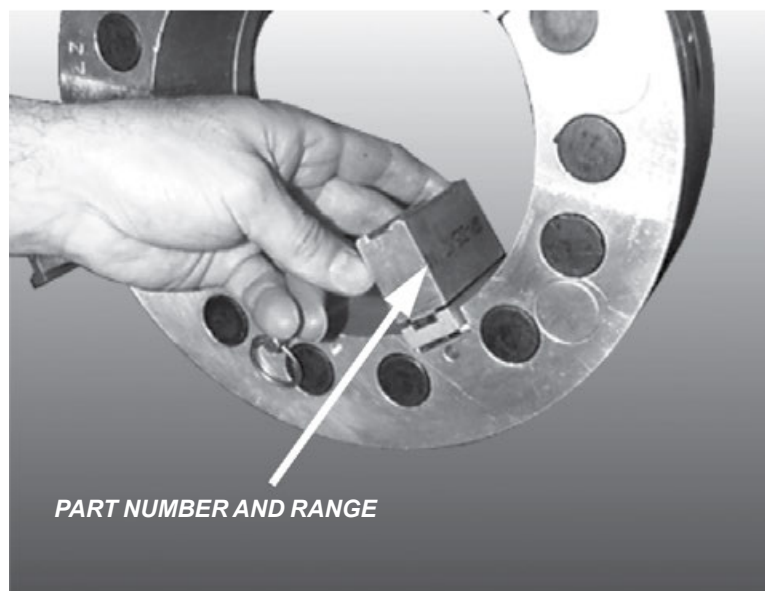

Figure 5-14. Install the legs onto the clamp pads.

CLAMP PAD EXTENSION CHART: LCSF 204-610 (4"-10")

CLAMPING RANGE		LCSF 204		LCSF 206		LCSF 408		LCSF 610	
		INCH	MM	INCH	MM	INCH	MM	INCH	MM
WITH NO EXTENSION	MAX	4.75	120.7	6.88	174.6	8.88	225.4	11.00	279.4
	MIN	3.51	89.1	5.62	142.7	7.16	193.3	9.51	241.6
60-408-05 1/2" EXT. SET	MAX	3.75	95.2	5.86	148.9	7.86	199.6	9.98	253.5
	MIN	2.52	63.9	4.62	117.3	6.61	167.9	8.51	216.2
60-408-07 3/4" EXT. SET	MAX	3.25	82.7	5.37	136.3	7.36	186.9	9.48	240.8
	MIN	2.03	51.5	4.12	104.7	6.11	155.2	8.01	203.5
60-408-10 1" EXT. SET	MAX	2.76	70.1	4.87	123.6	6.86	174.3	8.98	228.1
	MIN	1.55	39.3	3.62	92.1	5.61	142.3	7.51	190.8
60-408-15 1-1/2" EXT. SET	MAX	1.79	45.4	3.87	98.4	5.86	148.9	7.98	202.7
	MIN	1.18	29.9	2.64	67.0	4.62	117.3	6.52	165.5
60-408-20 2" EXT. SET	MAX			2.89	73.3	4.87	123.6	6.98	177.4
	MIN			1.67	42.3	3.62	92.1	5.52	140.2
60-408-25 2-1/2" EXT. SET	MAX			1.91	48.5	3.87	98.4	5.99	152.1
	MIN			1.18	29.9	2.64	67.0	4.52	114.9
60-408-28 2.8" EXT. SET	MAX			1.43	36.4	3.38	85.8	5.49	139.4
	MIN			1.18	29.9	2.15	54.6	4.03	102.3
60-408-30 3" EXT. SET	MAX					2.89	73.3	4.99	126.8
	MIN					1.67	42.3	3.53	89.7
60-408-31 3-1/8" EXT. SET	MAX					2.63	66.8	4.73	120.2
	MIN					1.42	36.1	3.27	83.2
60-408-35 3-1/2" EXT. SET	MAX					1.91	48.5	4.00	101.5
	MIN					1.01	25.6	2.55	64.7
60-408-40 4" EXT. SET	MAX							3.01	76.4
	MIN							1.58	40.1

CLAMP PAD EXTENSION CHART: LCSF 612-1420 (12"-20")

CLAMPING RANGE		LCSF 612		LCSF 814		LCSF 1016		LCSF 1420	
		INCH	MM	INCH	MM	INCH	MM	INCH	MM
WITH NO EXTENSION	MAX	13.00	330.2	14.25	362.0	16.25	412.8	20.25	514.4
	MIN	11.51	292.3	12.76	324.0	14.76	374.8	18.75	476.2
60-408-05 1/2" EXT. SET	MAX	11.98	304.2	13.23	335.9	15.22	386.7	19.22	488.3
	MIN	10.51	266.9	11.76	298.6	13.76	349.4	17.75	450.9
60-408-07 3/4" EXT. SET	MAX	11.48	291.5	12.73	323.2	14.72	374.0	18.72	475.6
	MIN	10.01	254.2	11.26	285.9	13.26	336.7	17.25	438.2
60-408-10 1" EXT. SET	MAX	10.98	278.8	12.23	310.5	14.22	361.3	18.22	462.9
	MIN	9.51	241.5	10.76	273.2	12.76	324.0	16.75	425.5
60-408-15 1-1/2" EXT. SET	MAX	9.98	253.5	11.23	285.2	13.23	335.9	17.22	437.5
	MIN	8.51	216.2	9.76	247.9	11.76	298.6	15.75	400.2
60-408-20 2" EXT. SET	MAX	8.98	228.1	10.23	259.8	12.23	310.5	16.22	412.1
	MIN	7.51	190.8	8.76	222.5	10.76	273.2	14.75	374.8
60-408-25 2-1/2" EXT. SET	MAX	7.98	202.7	9.23	234.4	11.23	285.2	15.22	386.7
	MIN	6.52	165.5	7.76	197.1	9.76	247.9	13.76	349.4
60-408-28 2.8" EXT. SET	MAX	7.48	190.1	8.73	221.8	10.73	272.5	14.72	374.0
	MIN	6.02	152.8	7.26	184.5	9.26	235.2	13.26	336.7

CLAMP PAD EXTENSION CHART: LCSF 612-1420 (12"-20")

CLAMPING RANGE		LCSF 612		LCSF 814		LCSF 1016		LCSF 1420	
		INCH	MM	INCH	MM	INCH	MM	INCH	MM
60-408-30 3" EXT. SET	MAX	6.98	177.4	8.23	209.1	10.23	259.8	14.22	361.3
	MIN	5.52	140.2	6.76	171.8	8.76	222.5	12.76	324.0
60-408-31 3-1/8" EXT. SET	MAX	6.72	170.8	7.97	202.5	9.97	253.2	13.96	354.7
	MIN	5.26	133.6	6.50	165.2	8.50	215.9	12.50	317.4
60-408-35 3-1/2" EXT. SET	MAX	5.99	152.1	7.23	183.7	9.23	234.4	13.23	335.9
	MIN	4.52	114.9	5.77	146.5	7.76	197.2	11.76	298.6
60-408-40 4" EXT. SET	MAX	4.99	126.8	6.24	158.4	8.23	209.1	12.23	310.5
	MIN	3.53	89.7	4.77	121.2	6.76	171.8	10.76	273.2

Set-Up for In-line Pipe

To mount the LCSF on in-line pipe, you will have to split the machine into halves by removing the frame locking screws at the split points.

1. Make sure the two frame locking pins are installed to keep the rotating and stationary rings together.

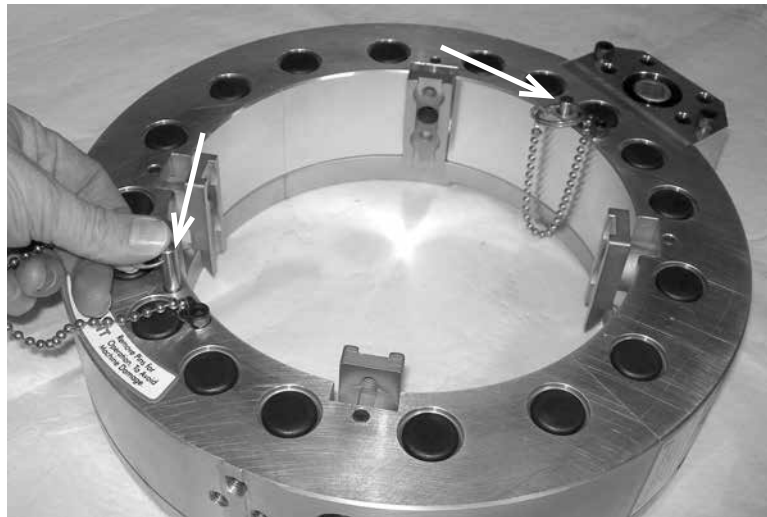

Figure 5-15. Insert the frame locking pins through the machine.

2. Lay machine on a secure surface.
3. Using a 1/4" hex wrench, loosen the 6 captivated screws, four in the stationary frame and two in the rotating frame.



Figure 5-16. Loosen the captivated screws to separate the halves.

4. Pull the two halves of the machine apart at the split lines. Use an equal amount of force on each side to prevent the halves from binding.



NOTE

Use reasonable force to separate the halves. If you can't pull them apart, check to make sure you have adequately loosened the 6 captivated screws.

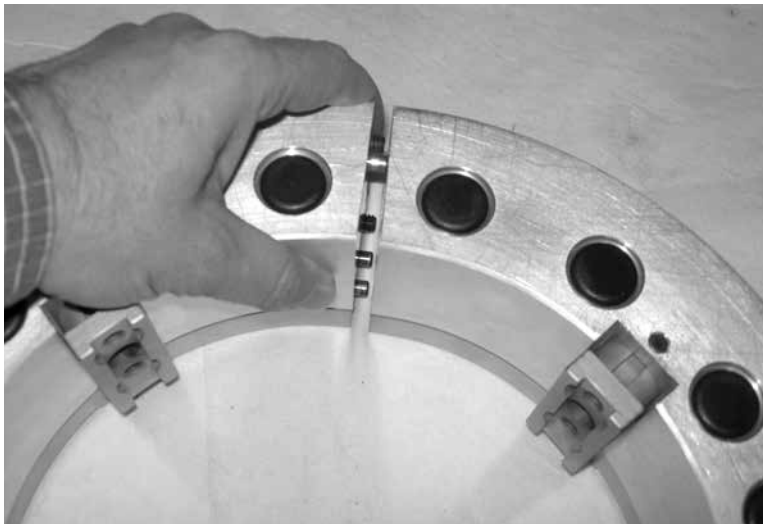

Figure 5-17. Pull the machine apart at the split lines. Use equal force on each side to separate the halves without binding.

5. With the halves split, place the upper half (with the pinion housing) on top of the workpiece. **Make sure you are attaching the stationary frame to a section of the pipe that will**

support its weight. Do not clamp the machine onto a pipe section or end that will “fall off” after cutting.



NOTE

For machines 12 inches and larger, two people will be required to perform the set-up.



Figure 5-18. On horizontal pipe, set the side of the machine with the pinion housing on top of the pipe.

6. Lift the bottom half of the machine into place under the top half. Align the dowel pin holes with the dowel pins to ensure proper fit, and press the halves together.



NOTE

To install the machine on vertical pipe, you will need two people to support both halves, or a stable support beneath the machine.



Figure 5-19. Fit the halves together on the pipe.

- 7.** Partially tighten one of the frame locking SHCS in the rotating frame. This will secure the machine while the other bolts are tightened.



IMPORTANT

Be sure that all frame locking SHCS are equally tightened before continuing with mounting procedure. Failure to do so may cause damage to drive gears.

- 8.** Using a 1/4" hex wrench, snug down all of the frame locking screws to bring the split lines together, then securely tighten the screws.

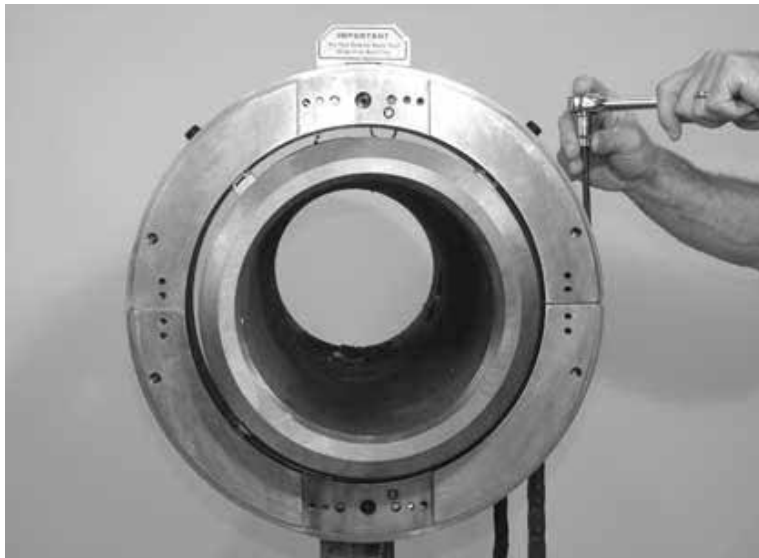

Figure 5-20. Tighten the frame locking screws.

Set-Up for Open-Ended Pipe

For open-ended workpieces, slide the machine over the pipe end. It is not necessary to split the machine. **Make sure you are attaching the stationary frame to a section of the pipe that will support its weight. Do not clamp the machine onto a pipe section or end that will “fall off” after cutting.**

Make sure all locking frame screws are tight and detent pins are installed in the machine. Use the same clamping and positioning procedures as for in-line pipe.

Installation on Vertical Pipe

The LCSF can be installed on in-line or open-ended vertical pipe, with the machine in a horizontal position. Set-up and operating procedures are the same as for horizontal pipe. However, observe the following guidelines for machining vertical (or other non-horizontal angle) workpieces.



NOTE

For difficult installation environments, a custom mounting adapter can be provided. The adapter can be bolted or welded to the workpiece to hold the LCSF in place for installation. Contact E.H. Wachs customer support to discuss requirements.

- Make sure the machine is adequately supported until you tighten the clamp feet securely on the workpiece.
- Refer to the weight chart in Chapter 2 to determine if multiple operators or a lifting device are needed to help support the machine.
- The LCSF is easier to handle in a horizontal position when the ring halves are assembled. If possible, install it as an assembled ring.
- If you need to split the machine to install on in-line pipe, make sure each half is supported until installation is complete. Two lifting devices may be required, one for each half of the machine.
- Use a scaffolding or other support structure(s) if available. Make sure the LCSF rests stably on the support.
- When performing a parting operation, make sure the workpiece is securely supported both above and below the LCSF.

Positioning the Machine for the Cut

1. With the frame halves securely tightened, move the machine to the cut line position marked on the pipe.
2. Using the scale, set your machine 2-1/4" (57 mm) back from the line or punch mark at the position where you mount the tool slides. (See the cut line identified in the envelope drawings in Chapter 3.)

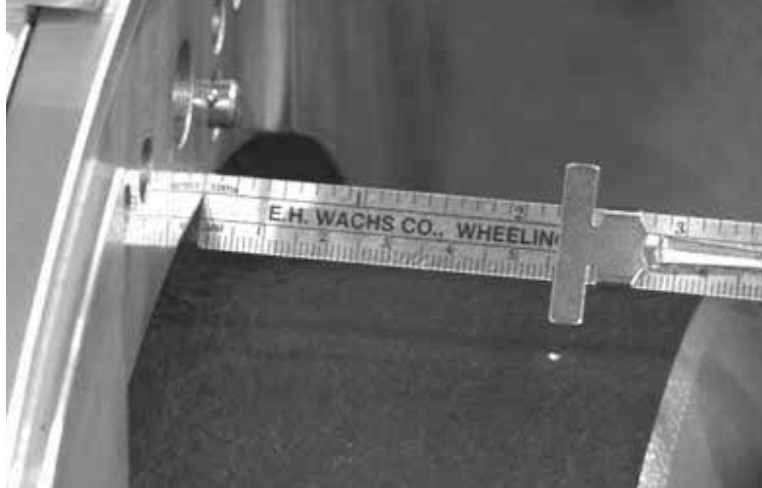

Figure 5-21. Measure 2-1/4" back from the punch mark.

Clamp Pad Centering Procedure

1. Starting with the clamp pad nearest the 12 o'clock position, tighten the clamping screw until the gap at the top and the bottom of the machine are approximately equal.



NOTE

For easy visualization, we often refer to positions on the LCSF by numbers on a clock.

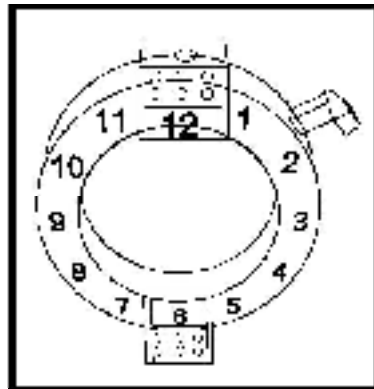

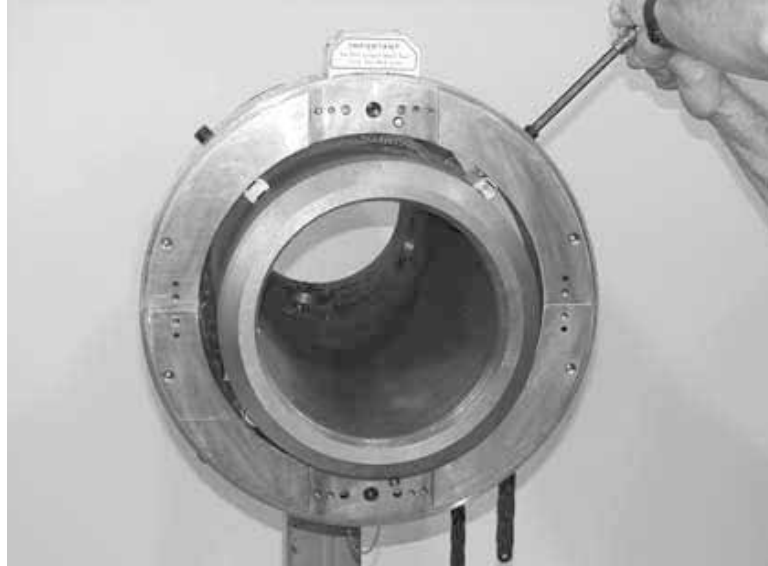

2. Snug the clamp pad nearest the 6 o'clock position.



NOTE

Clamp legs are secured with Integrated Captivated Socket Head Cap Screws (SHCS) to secure themselves to the stationary ring.

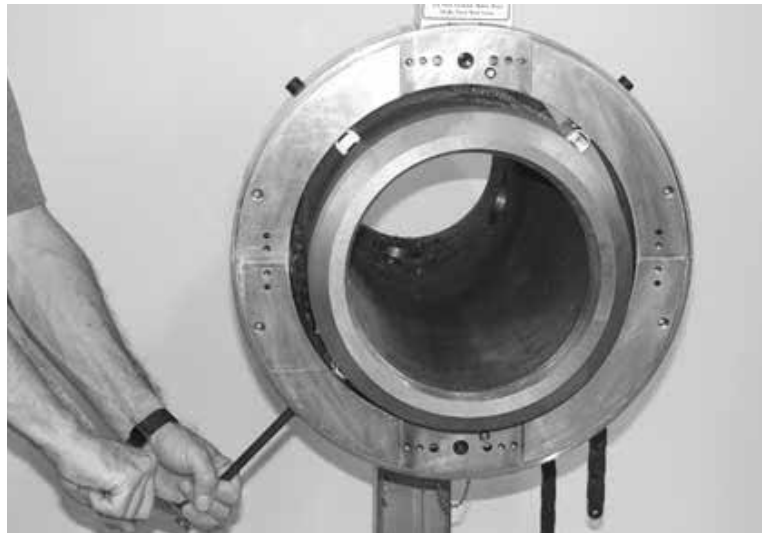

Figure 5-22. Tighten the clamping screw until the leg is just snug on the pipe.

3. Snug the clamping screws nearest the 3 and 9 o'clock positions. At this point the machine is rough centered and you may begin making the final adjustments.
4. Place the short end of the provided square on the pipe with the ruler side against the stationary ring at the 12 o'clock position. Check the LCSF's squareness to the O.D. of the pipe. If there is a gap, adjust the machine until the gap is closed.



NOTE

With the clamping screws snug, you should be able to nudge the LCSF on the pipe. If necessary, SLIGHTLY loosen the clamp pads at the 6 and 12 o'clock position, or the 3 and 9 o'clock positions. You can tap on the LCSF with the provided rubber hammer to nudge it.

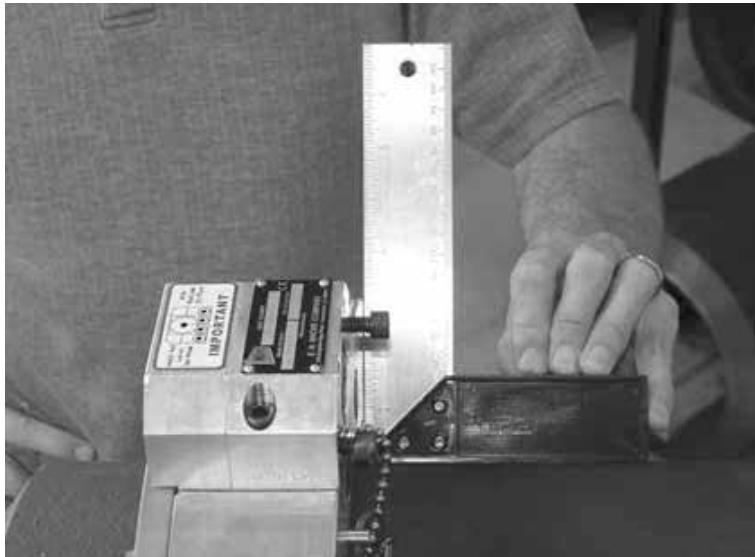

Figure 5-23. Use the square to make sure the machine is perpendicular to the pipe.

- 5.** When the LCSF is square to the pipe, check the distance from the slide mounting location on the machine to the cut line. It should be 2-1/4" (57 mm). If necessary, nudge the machine to adjust the position.
- 6.** When the LCSF is square and at the correct location, tighten the clamping screws.
- 7.** Start at the clamp leg nearest the 12 o'clock position. Using a scale, measure the distance from the surface of the pipe to the inner surface of the LCSF at that location. Write the measurement down.



Figure 5-24. Measure the gap at the clamp leg nearest the 12 o'clock position.

8. Move to the clamp leg 180° opposite the one in the previous step and measure the distance between the pipe surface and the inner surface of the LCSF. Write this measurement down.
9. Add the two measurements together. Divide the result by 2. This number is the distance the LCSF should be from the pipe at both clamp pad locations.

EXAMPLE:

- The distance at the first location is 1.7 inches.
 - The distance at the second location is 2.1 inches.
 - Add 1.7 to 2.1, then divide by 2. The result is 1.9 inches, which is the desired distance between the pipe and LCSF at each location.
10. Using the scale as you make the adjustments, turn the clamp pad screws alternately until you have the same pipe-to-LCSF distance at both locations.
 11. Repeat this procedure at the two clamp leg locations 90° from the first two.
 12. Measure at all four locations again. Re-adjust if necessary.



NOTE

You should make a final check for squareness after the clamp pads are tightened.

13. Remove the frame locking pins and manually rotate the machine a full 360°.



Figure 5-25. Remove the frame locking pins.

14. If you can't turn the rotating frame by hand, the clamp legs may be too tight, binding the machine. One at a time, loosen and then re-snug the clamping screws. Try to rotate the machine again.

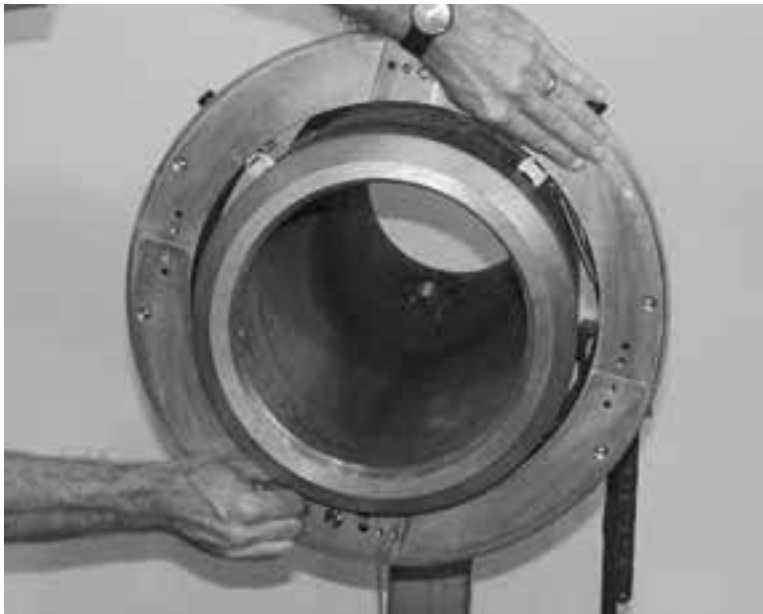

Figure 5-26. Rotate the machine by hand.

15. If you still can't turn the machine, see the section "Bearing Adjustment" in Chapter 7.

INSTALL TOOL SLIDES AND TOOLING

Standard Slides

The standard slides for LCSF models 204-1420 are the “extended” parting and beveling slides (part nos. 60-415-00 and 60-416-00).

On the back of each of the tool slides are pairs of holes for three mounting positions, as shown in Figure 5-27. Two mounting pins are provided to use in the appropriate hole pair. The hole pairs represent the three possible mounting positions: high (farthest from machine I.D.), middle, and low (closest to machine I.D.).

Choose the lowest slide position that will not collide with the pipe surface. (Refer to the operating envelope drawings in Chapter 3.) This minimizes the extended length of the tool, increasing rigidity of the cutting system.

- 1.** Insert the mounting pins in the required holes for the pipe size:
 - Use the “high” position if the pipe diameter is less than 2” (51 mm) smaller than the machine size (for instance, 12.5” pipe with 14 inch LCSF).
 - Use the “middle” position if the pipe diameter is 2”-4” (51-102 mm) smaller than the machine size (for instance, 11” pipe with 14 inch LCSF).
 - Use the “low” position if the pipe diameter is more than 4” (102 mm) smaller than the machine size (for instance, 9” pipe with 14 inch LCSF).

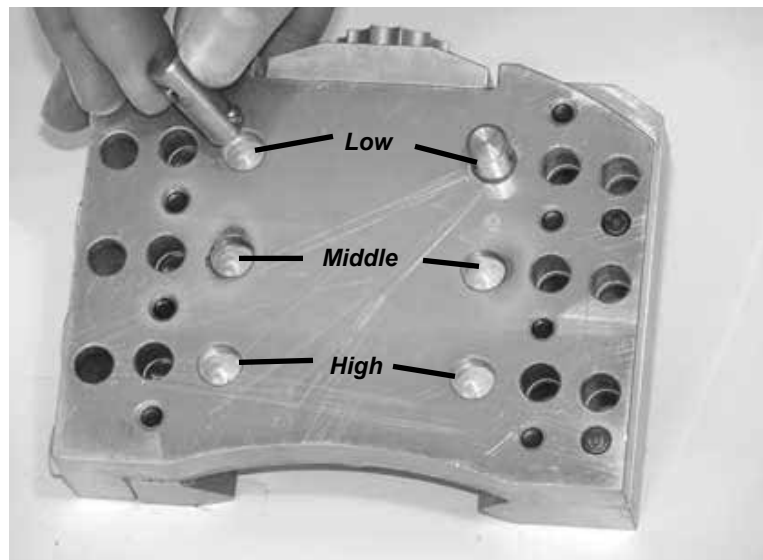

Figure 5-27. Insert the mounting pins in the slide.

- 2.** Mount the tool slide to the rotating frame by inserting the pins in the mounting holes at each slide position. Tighten the four 5/16 -18 SHCS in each slide with the supplied hex key set.



Figure 5-28. Tighten the SHCS on each side of the tool slide.

3. Using a 3/16" hex wrench, turn the starwheels on both slides clockwise to fully retract the slides.

Low-Clearance Slides

The low-clearance slides have fixed mounting pins and only one mounting position. The parting slide number is 60-402-04, and the beveling slide number is 60-403-04.

1. Mount the tool slides to the rotating frame by inserting the pins in the mounting holes at each slide position. Tighten the four 5/16 -18 SHCS in each slide with the supplied hex key set.
2. Using a 3/16" hex wrench, turn the starwheels on both slides clockwise to fully retract the slides.

Install the Tooling

For a straight cut-off operation, install a parting tool in both the parting and beveling slide. **It is important that you use two parting tools.** The tools are offset to prevent binding and stalling of the machine.

For a parting and bevel operation, install a parting tool and a beveling tool. See the information in "Tool Selection" earlier in this chapter.

1. To install parting tools, loosen the 2 tool set screws and the 4 tool cover screws. Insert the tool as shown in Figure 5-29.

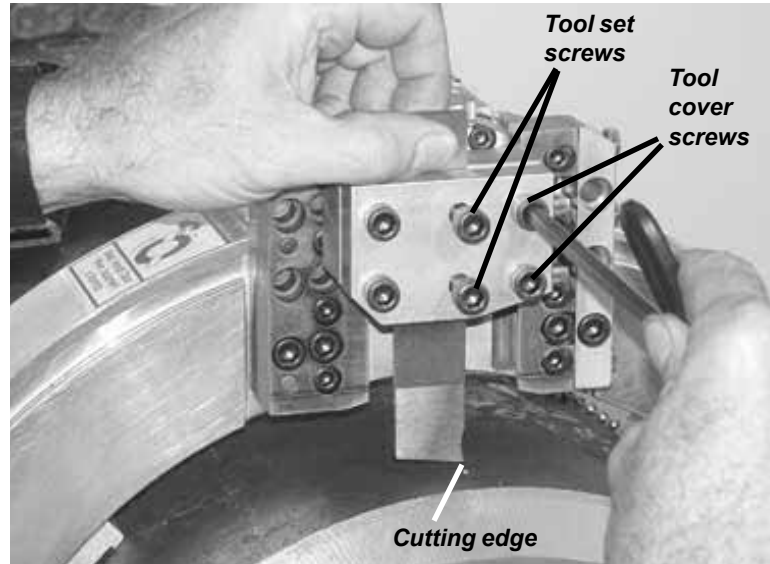

Figure 5-29. Installing the parting tool with the cutting edge in the cutting direction as shown.

2. Snug all 4 tool cover screws, then tighten them.
3. Tighten the 2 tool set screws.
4. To install a beveling tool, loosen the 2 tool set screws in the tool cover plate, and the set screw in the side of the tool holder.

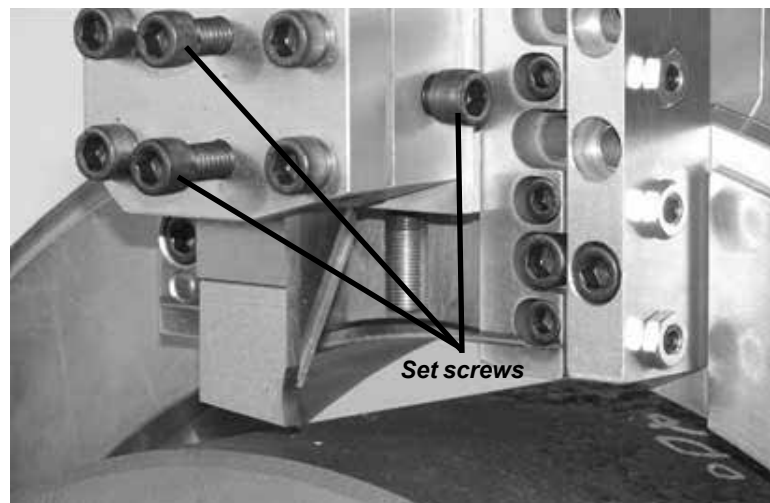

Figure 5-30. There are three set screws for beveling tools.

5. Insert the beveling tool with the cutting edge in the direction of rotation, as shown in Figure 5-31.

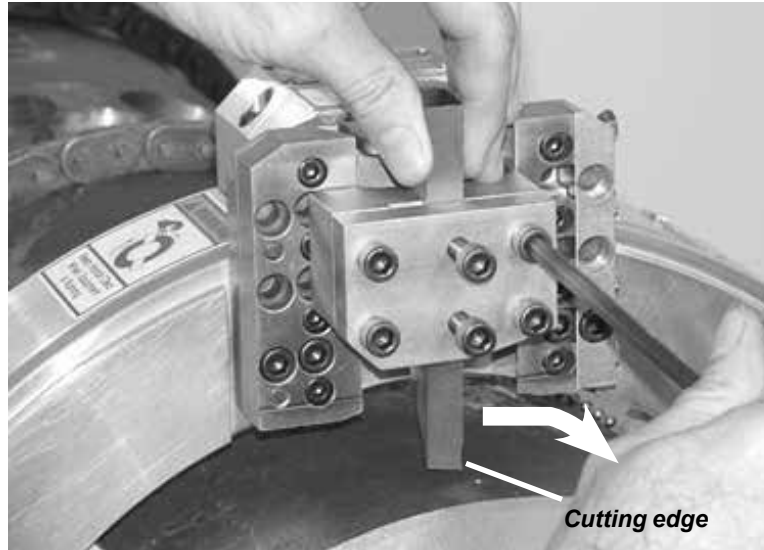

Figure 5-31. Insert the bevel tool in the holder with the cutting edge in the direction of rotation.

- 6.** Snug the set screw on the side of the tool holder, then tighten the 2 set screws on the tool cover. Tighten the side set screw.
- 7.** Turn the rotating ring by hand to check the tooling clearances. Make sure the tools do not touch the pipe, and that there is enough slide travel for the tooling to reach the I.D. Refer to the slide envelope drawings in Chapter 3.
- 8. Set the tooling.** Bring the parting tool 1/8 inch away from the pipe and the bevel tool 1/8 inch away from the pipe. Check tool extension and slide travel again, as in the previous step.

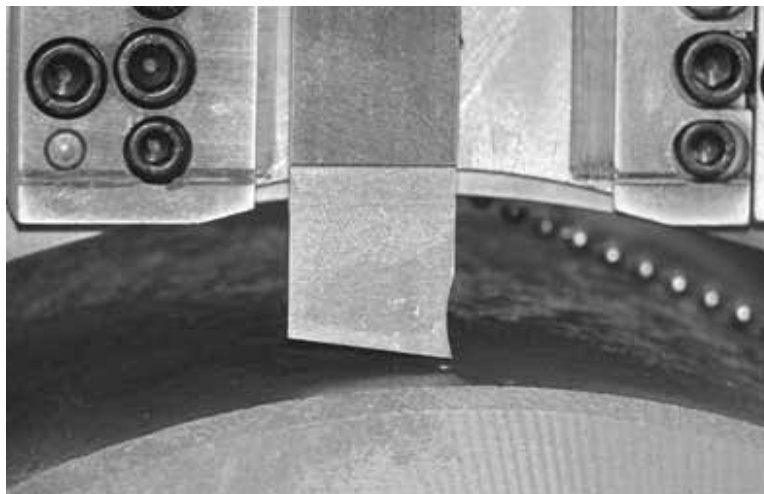

Figure 5-32. The tip of the parting tool should be about 1/8" (3 mm) from the pipe surface.

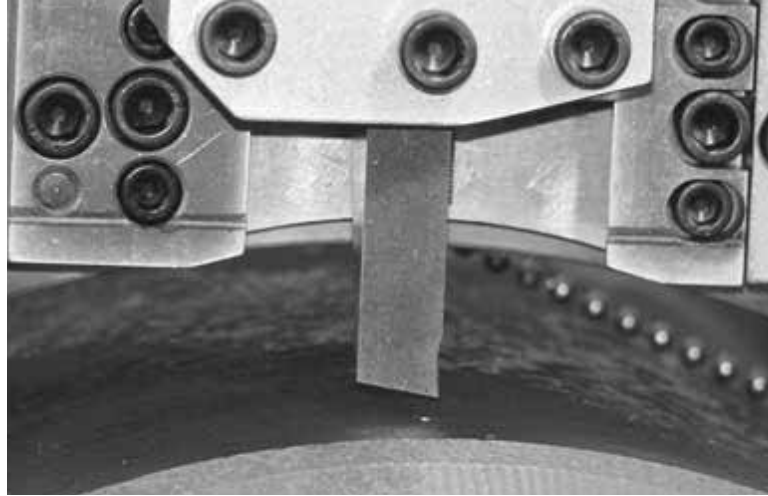

Figure 5-33. The tip of the beveling tool should be about 1/8" (3 mm) from the pipe surface.

9. Rotate the machine manually to make sure the tool clears all the way around the pipe.



Figure 5-34. Rotate the machine to check tool clearances.

Dual Tooling Setup

You can “stack” parting and beveling tools in the beveling slide to prevent tool binding on heavy-wall pipe. This setup helps clear chips as the cutting groove deepens.

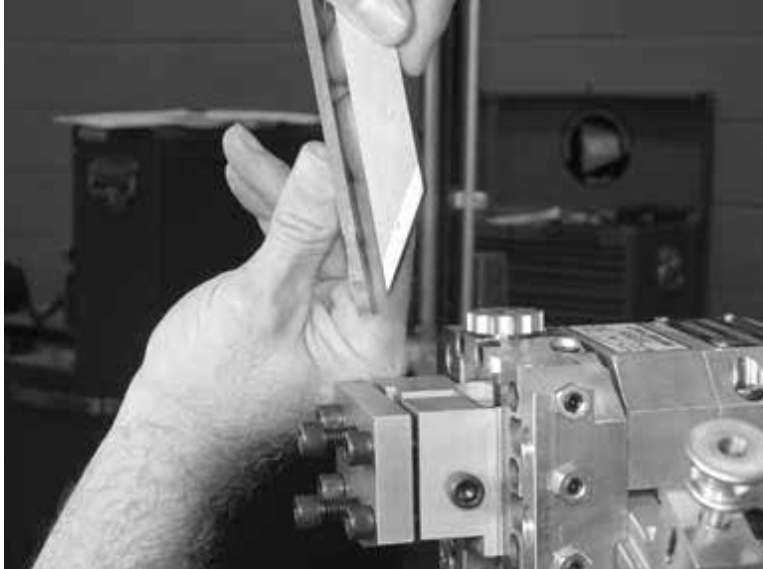

Figure 5-35. You can use a combination of parting and beveling tools in the beveling slide.

- 1.** Install the required parting tool in the parting slide tool holder. Set the cutting tip of the tool 1/16” from the surface of the pipe and tighten the screws in the tool cover.
- 2.** Install the required beveling tool in the beveling slide tool holder. Set the cutting edge of the beveling tool 1/16” from the surface of the pipe.
- 3.** Snug the screws on the beveling tool cover, then securely tighten the screw(s) on the tool block holding the side of the tool. (Number of screws depends on the slide model.)
- 4.** Loosen the screws in the beveling tool cover and insert the parting tool on top of the beveling tool.

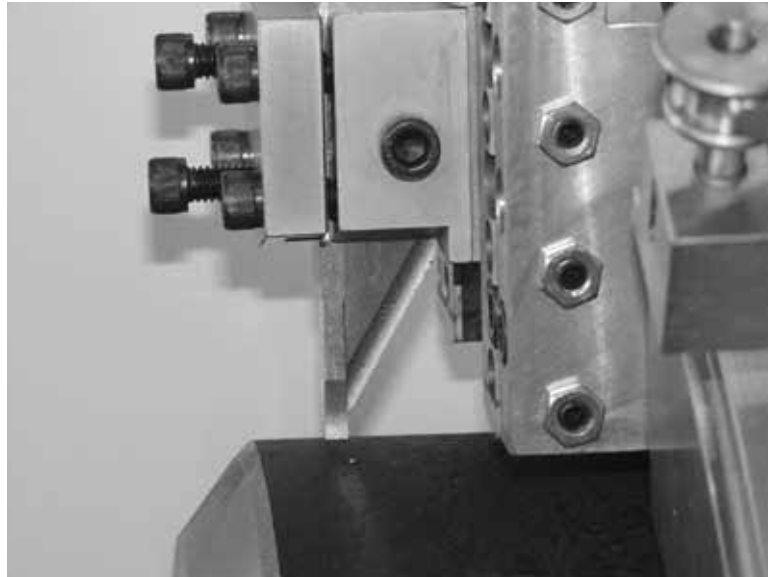

Figure 5-36. Insert the tooling as shown with the offset between the parting blades at 1/16 inch from each other.

- 5.** Adjust the position of the parting tool in the beveling slide for the desired land thickness. To increase the land, set the parting tool beyond the tip of the beveling tool. The land thickness will be $3/32''$ plus the distance the parting tool extends past the beveling tool.
- 6.** Start the tooling with a $1/16$ to $1/8$ inch gap from the pipe surface and proceed to the installation of the trip assembly.



NOTE

Example: For a $1/4''$ land, extend the parting tool $5/32''$ beyond the beveling tool ($3/32'' + 5/32'' = 1/4''$).



Figure 5-37. Set the tip of the parting tool 1/8" (3 mm) from the pipe surface.

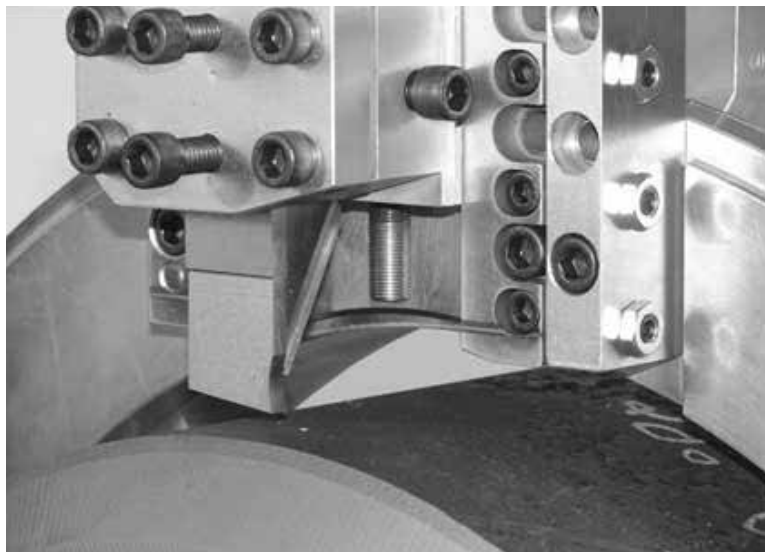

Figure 5-38. The photo shows the parting tool 1/8" (3 mm) above the punch mark.

Install the Trip Assembly

Configure the trip assembly for the slide position on the LCSF (low, middle, or high position).

- Attach the trip directly (with **no extension blocks**) to the LCSF for slides in the **low position**.
- Attach the trip with **one extension block** for slides in the **middle position**.
- Attach the trip with **two extension blocks** for slides in the **high position**.

Different length screws are provided for each configuration.



Figure 5-39. The trip assembly is provided with 2 extension blocks, and 3 sizes of screws for the 3 configurations (no block, 1 block, or 2 blocks).

1. Pull out the trip lever swivel pin and remove the lever from the trip assembly.



Figure 5-40. Pull out the pin and remove the trip lever.

2. If extension blocks are required, align the block(s) with the bottom of the trip mount. Stack the blocks so that the raised tabs on the top interlock with the slot on the bottom of the adjacent piece.

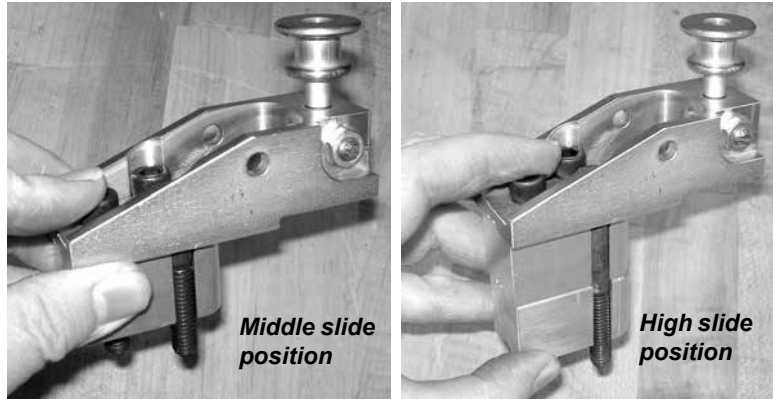

Figure 5-41. Use the required number of extension blocks for the slide position.

3. Insert the required screws through the base of the trip mount and the holes in the extension block(s), as shown above.
4. Put the trip assembly in place on the stationary ring and tighten the three screws.

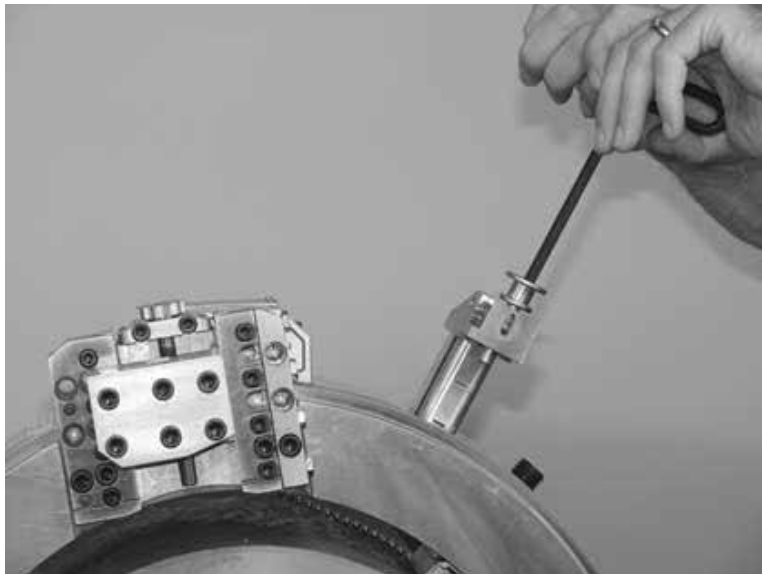

Figure 5-42. The trip assembly is shown with 2 extension blocks, corresponding to the slides in the “high” position.

5. Put the trip lever in place, with the “fork” in the lever engaged on the trip plunger. Insert the swivel pin.
6. Push the trip lever down to disengage the trip.

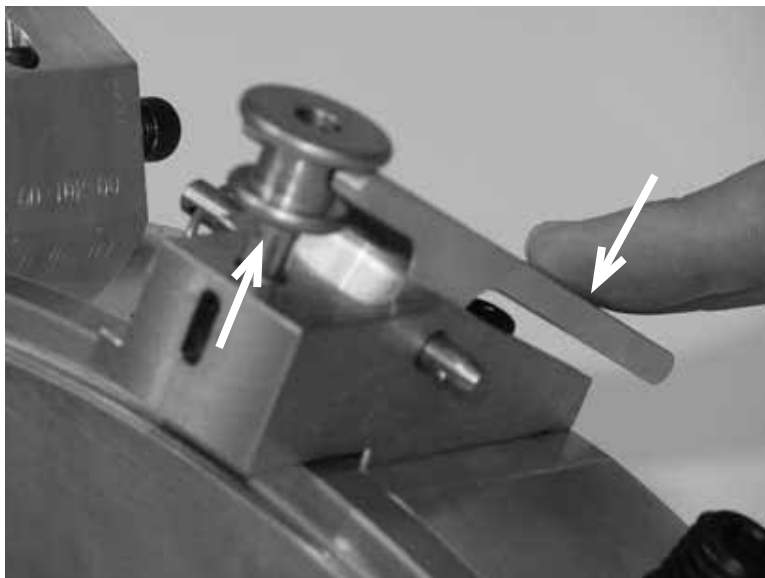

Figure 5-43. Push the trip lever down to lift the trip pin into the disengaged position.

7. Time the starwheel feed system and take all the backlash out of the feed mechanism.



NOTE

The feed rate for all tool slides is 0.0312" (0.79 mm) per revolution of the starwheel. This equals 0.0026" (0.066 mm) per revolution of machine.

- To take the backlash out, turn the starwheel counter-clockwise (direction of feed) until all backlash is gone and you can feel a slight resistance.
- To time the starwheel, make sure a point of the star is aligned with the machined line (usually marked in red) on the top of the tool block.



Figure 5-44. Time the starwheel. You can align any point of the wheel with the red line on the tool block.

8. Repeat step 5 for the other slide.
9. Engage the trip pin by pulling up on the trip lever.

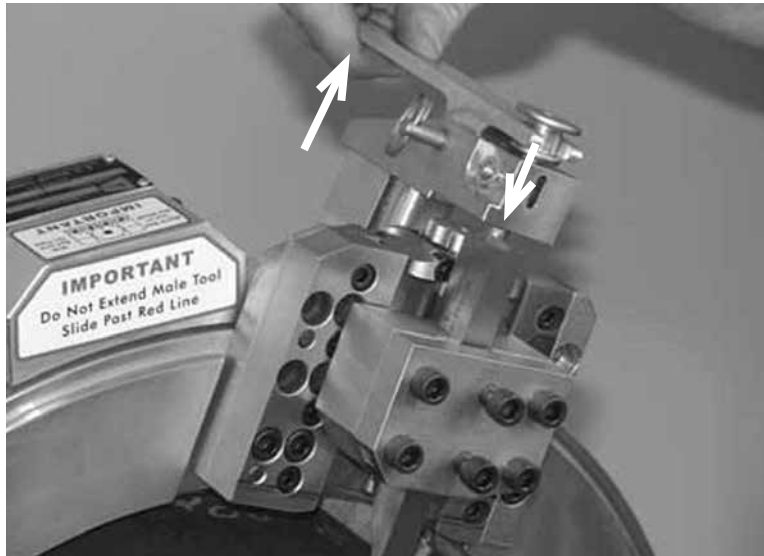

Figure 5-45. Engage the trip pin by pulling up on the paddle lever.

Install the Drive Motor

The air and hydraulic drive motors are provided with adapters to attach to the LCSF pinion housing. See the appropriate section below for the drive motor you are using.

Air Motor



NOTE

The drive motor may be placed in several different positions. The motor should be mounted in a position that allows the operator the easiest and safest access possible.

1. Loosen the two 5/16-18” SHCS located on the back of the pinion housing.
2. Align two of the bolt holes in the drive motor mounting flange with the two SHCSs in the pinion housing and slip the flange over the SHCS. All air motors use the same style flange.



Figure 5-46. Align the bolt holes in the motor flange with the two SHCS in the pinion housing.

3. Tighten the 2 motor mounting screws to secure the drive motor.



NOTE

The square drive shaft on the motor must insert fully into the socket in the pinion housing. If necessary, turn the rotating frame slightly back and forth by hand until the drive hex seats itself properly.

4. Re-time the starwheel.
5. Attach the power supply to the drive motor.

Hydraulic Motor

The hydraulic motor is supplied with an adapter to attach to the LCSF pinion housing. First attach the adapter to the LCSF, then mount the motor on the adapter.

1. The hydraulic motor is supplied with the adapter attached. Remove the two screws holding the motor to the adapter.



Figure 5-47. Remove the hydraulic drive screws to detach the drive motor from the adapter.

2. Remove the 2 motor mounting screws from the pinion housing and set them aside. The hydraulic motor adapter includes screws for mounting to the pinion housing.

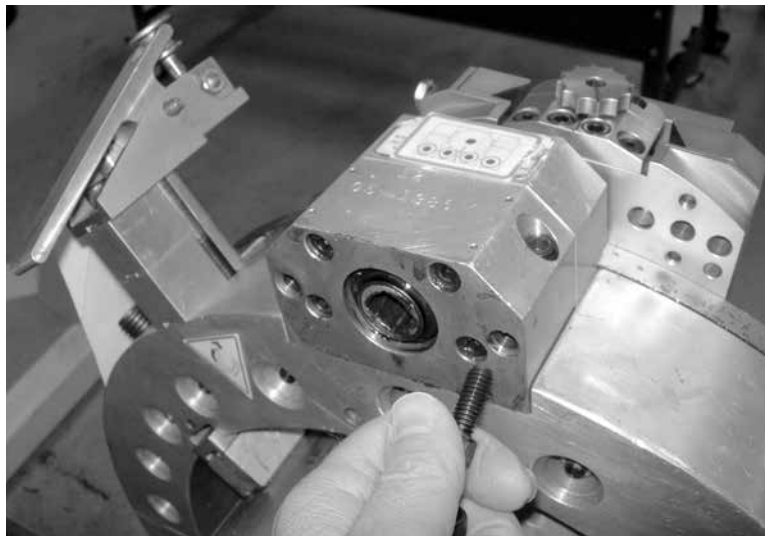

Figure 5-48. Remove the pinion housing motor mounting screws and store them in a secure place.

3. Attach the hydraulic motor adapter to the pinion housing and securely tighten the 2 screws.

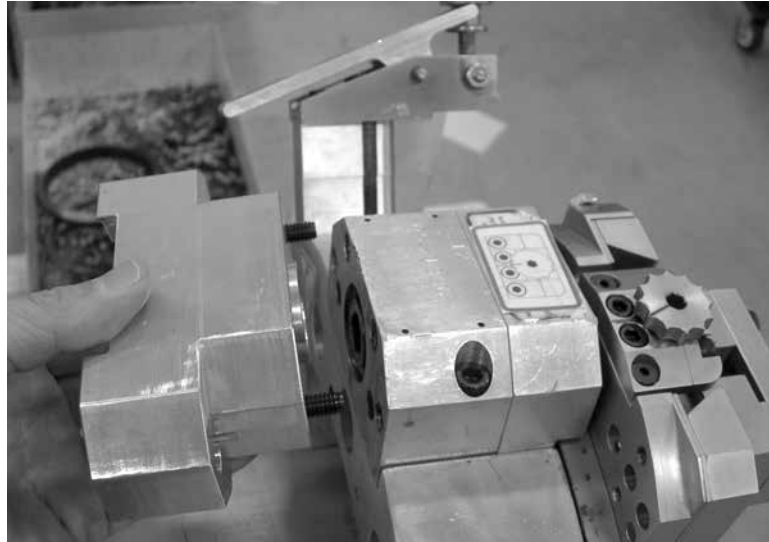

Figure 5-49. Attach the hydraulic drive adapter to the pinion housing.

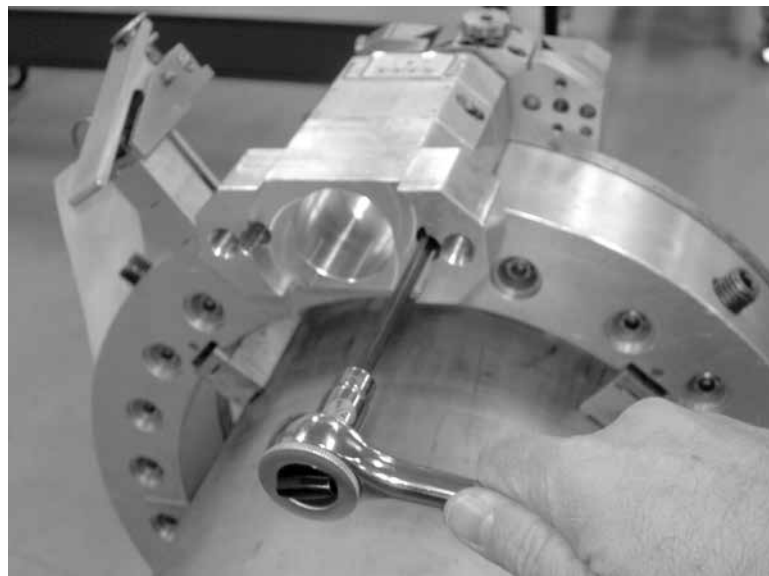

Figure 5-50. Tighten the 2 screws holding the hydraulic drive adapter to the pinion housing.

4. Insert the hydraulic motor shaft through the adapter so that the square shaft fits into the pinion. Turn the motor as required to align the shaft and fully seat the motor flange on the adapter.



NOTE

The drive shaft fits snugly into the socket in the pinion. You may have to “wiggle” the drive to insert the shaft into the socket.

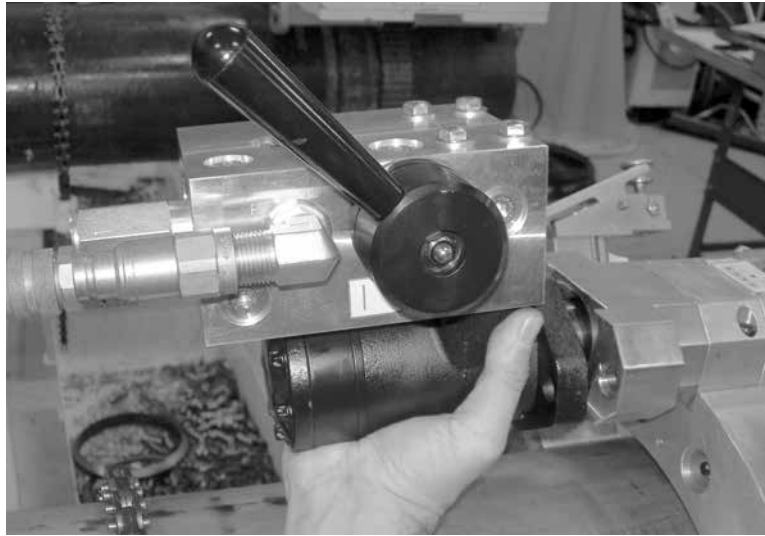

Figure 5-51. Insert the hydraulic drive shaft through the adapter so that the square drive fits into the pinion socket.

- 5.** Attach the motor to the adapter using the 2 screws provided. Tighten the screws securely.

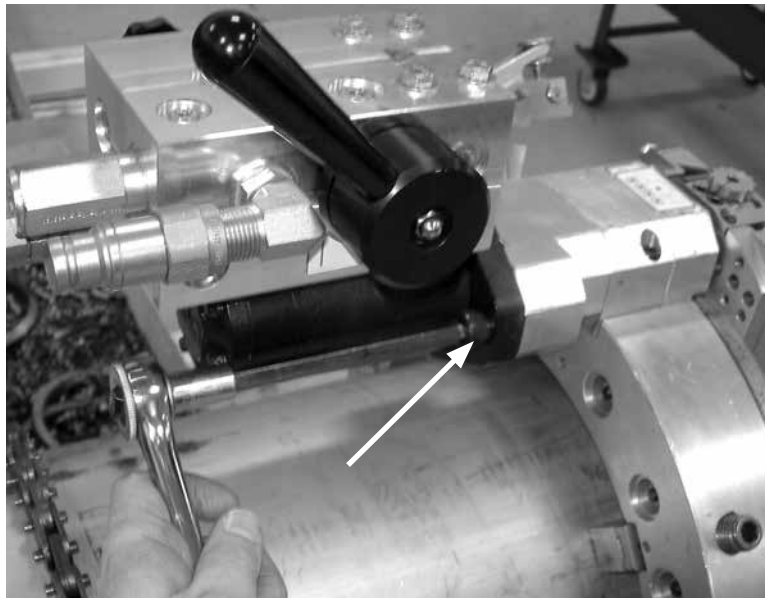

Figure 5-52. Tighten the 2 screws holding the drive to the adapter.

- 6.** Connect the hydraulic hoses to the motor as shown. Make sure the pressure and return (tank) lines are connected to the correct fittings.



IMPORTANT

The standard hydraulic hose fittings are female for the pressure side and male for the return side. Make sure the fittings and connections are correct. Operating the LCSF in the reverse direction can damage the machine.

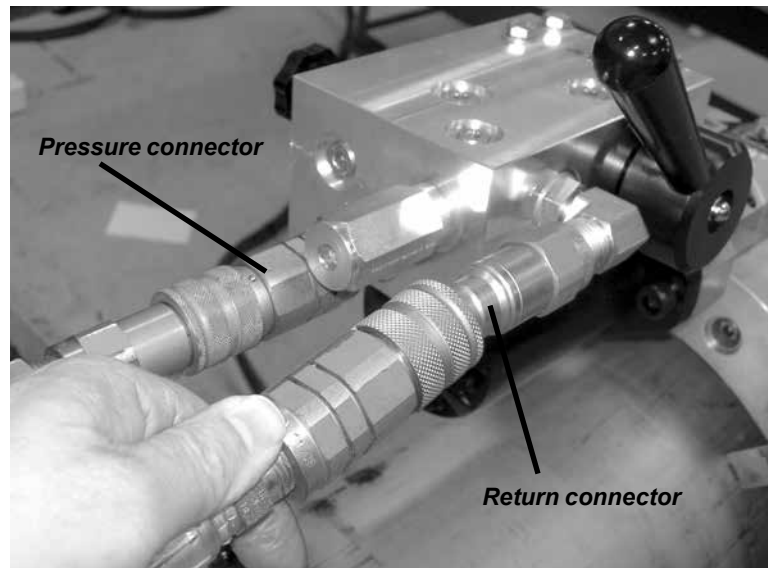

Figure 5-53. Connect the hydraulic hoses to the drive as shown.

CUTTING OPERATION

Set up the LCSF, tool slides, and drive motor as described in the previous sections.

If you are doing a severing operation, make sure the workpiece is adequately supported on both sides of the cut line. If necessary, use a catch device for the fall-off piece.



WARNING

Failure to support the workpiece and the fall-off piece could result in serious injury and/or damage to the machine.

1. Check that power connections (air or hydraulic) to the LCSF are securely attached.
2. Make sure that tooling is installed correctly and securely.
3. Turn on the power (air or hydraulic) at the source.

4. Set the speed control on the drive motor to the lowest setting. Engage the drive motor on/off lever to start the machine. If the machine does not start, increase the speed control slightly.



WARNING

Keep clear of moving parts while operating the LCSF.

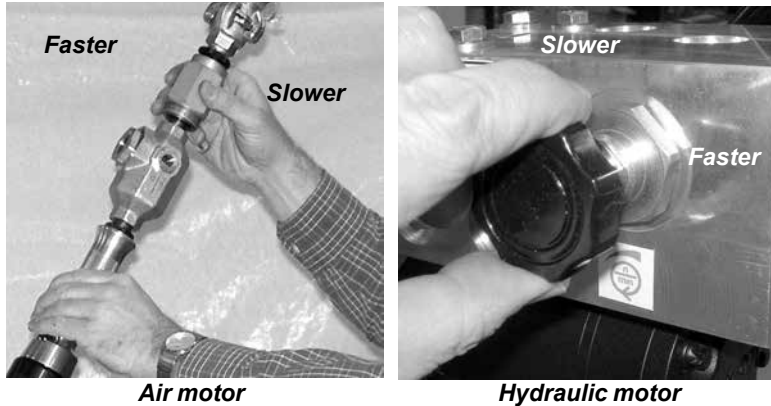

Figure 5-54. The photos show the speed adjustment controls on the drive motors. Set the speed control to the minimum before starting the LCSF on a new setup.

5. Engage the trip and operate the machine slowly (3-4 RPM) to verify that the trip is turning the starwheel.



NOTE

If the starwheel does not contact the trip pin smoothly, stop the machine immediately and follow starwheel timing procedures.

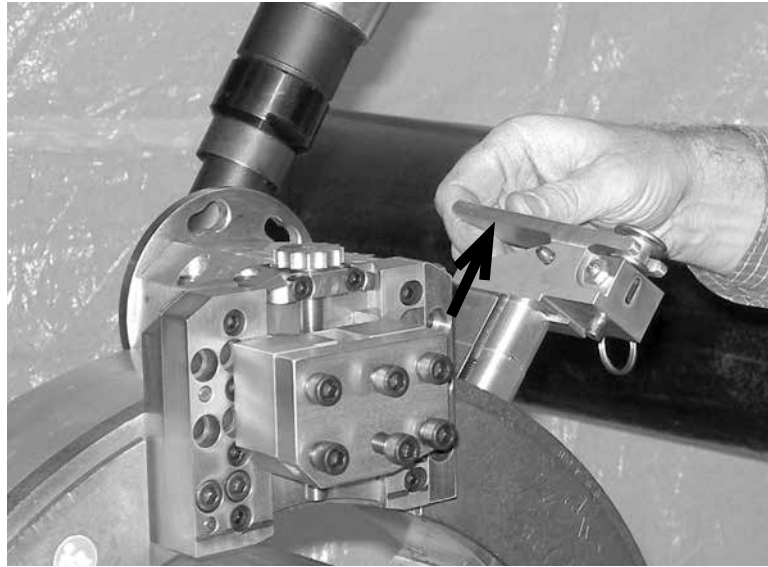

Figure 5-55. Pull the trip lever up to engage the trip.

- 6.** Set the speed control to increase the speed to the desired RPM. Continue machine operation. The tool slides will advance until the tools begin to cut the workpiece.

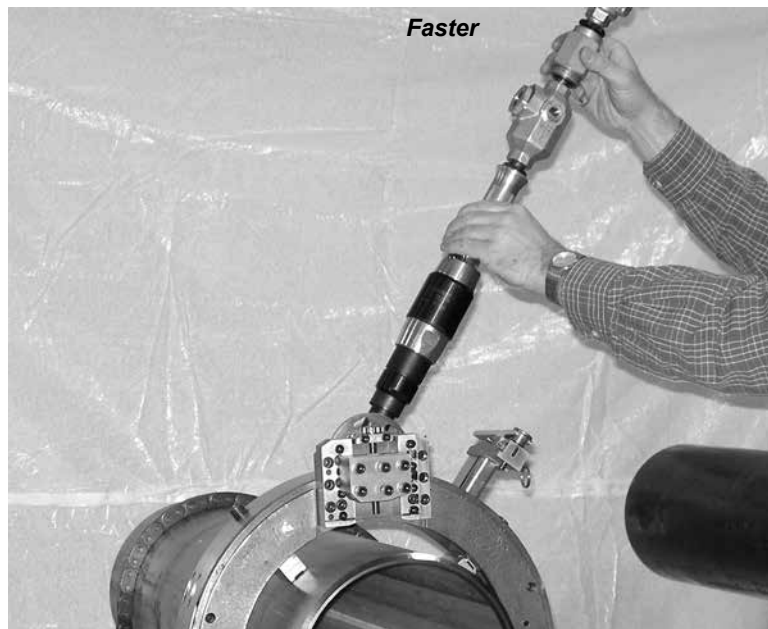

Figure 5-56. Turn the air motor throttle to increase the speed.

7. Once the tool bits begin to remove material from the workpiece, be sure to apply liberal amounts of coolant for the duration of the machining process.



NOTE

Using coolant is strongly recommended to enhance cutting and increase tool life. If worksite requirements prevent you from using coolant, you may need to adjust operating speed, feed rate (using the trip), or tooling.

8. You may need to disengage the trip occasionally to adjust the feed rate or to let chips clear out of the cut. Push the trip lever down as the machine is rotating, and operate the machine for 2-3 rotations. Pull the trip lever up to re-engage the trip and continue cutting.

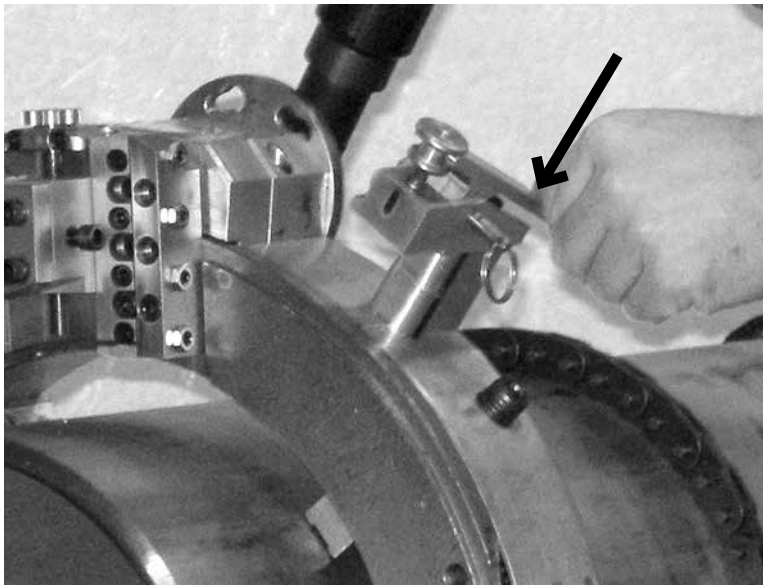

Figure 5-57. Push the trip lever down to disengage the trip.

9. If you need to manually clear chips from the cut or the machine, disengage the trip as described above. Then stop the machine before clearing chips.



WARNING

Use a wire brush or a pliers to avoid touching the chips, which can be hot and very sharp.
Wear appropriate gloves for cleaning up chips

10. When you have finished clearing chips, start the machine without the trip engaged. Operate it for at least one rotation before engaging the trip.

**CAUTION**

When cutting, never extend the male tool holder of the tool beyond the red line scribed on the tool slide body.



11. Continue operating the LCSF until the machining operation is complete.
12. Release the on/off lever to stop the LCSF.

COUNTERBORING

If a counterbore is to be performed, be sure to leave an oversized land. This will allow for material removal without violating the land thickness.

Planning the Operation

1. Determine the amount of material that needs to be machined from the I.D. of the pipe.

Measure the existing pipe I.D. and subtract this value from the “planned” I.D. The difference is the amount of material that needs to be machined from the existing pipe I.D.



Figure 5-58. Measure the I.D. of the pipe.

Example:

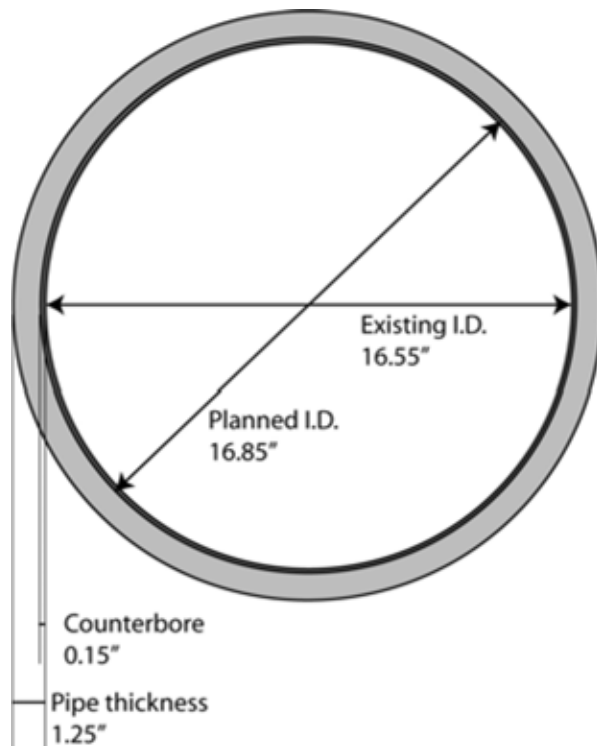

Figure 5-59. The width of the counterbore is $\frac{1}{2}$ of the difference between the existing I.D. and planned I.D.

Planned I.D. dimension	16.85"
Existing I.D. dimension	16.55"
Difference	0.30"
Divide by 2	0.15" Per side

Thus, the existing diameter needs to be counterbored to increase the existing I.D. by 0.30", or 0.15" per side.

2. Determine the thickness that can be removed with each pass.

As a rule of thumb, you can cut about 0.060" on most pipe materials without causing excess machine vibration, damaging the tooling, or stalling the machine. Depending on the material you are cutting, you may need to decrease this thickness. On some materials, you may be able to cut a thicker pass, but in general you should not exceed more than about half the width of the tool taper.

3. Determine the depth for the first counterbore pass.

Because the counterbore tool is tapered, you must start out making longer passes than the desired counterbore depth. Each pass is shorter than the previous one, until the final pass completes the I.D. of the required straight bore to the desired depth.

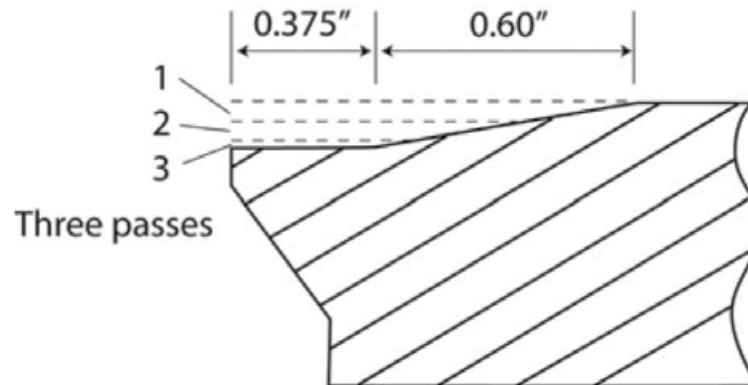

Figure 5-60. In this example, three passes with the counterbore tool are required to achieve the desired straight counterbore depth.

In Figure 5-61, the planned counterbore depth is 0.375" of straight bore. (This is a value that is specified in the weld prep detail.) A general rule of thumb is the counterbore depth is just deep enough to locate the transition of the straight bore/taper intersection out of the weld x-ray zone, or behind the end of the weld prep as shown in Figure 5-61.

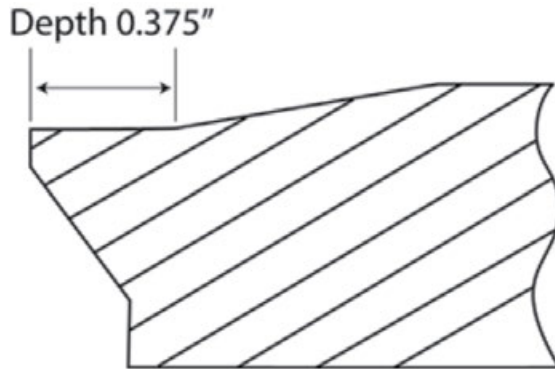

Figure 5-61. Counterbore depth

From Step 1, 0.15" needs to be removed from the wall thickness. If the taper on the counterbore tool bit is 4:1, we can determine the depth of the first counterbore pass:

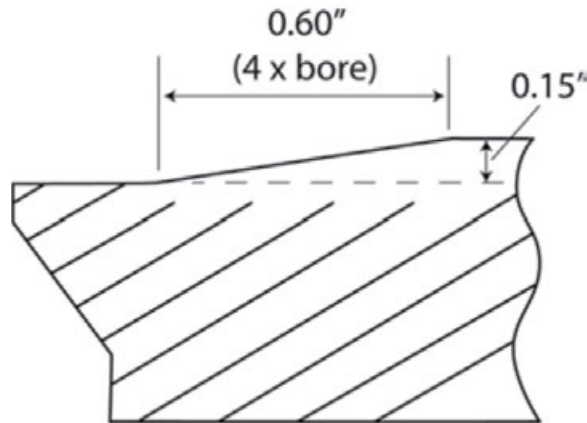

Figure 5-62. The depth of the tapered part of the bore is a function of the tool taper and the counterbore thickness.

$$\begin{aligned}
 0.15'' \times 4 \text{ (taper ratio)} &= 0.60'' \text{ (length of the tapered portion)} \\
 &+ 0.375'' \text{ (length of straight bore)} \\
 &= 0.975'' \text{ (Total counterbore depth including the lead out angle)}
 \end{aligned}$$

COUNTERBORE PLANNING FORMULA

The knowns: Angle = $14\ 1/2^\circ$ or 4 to 1 taper ratio

Material per pass .050

Total material removed of .150

Need to find how deep to bore, or *c* of our angle:

Side **b** = .150

Angle **B** = $14\ 1/2^\circ$

Formula to find Side *c*: **$c = b \times \cot. B$**

($\cot. B = 3.8667$)

$c = .150 \times 3.8667$ is .580

To calculate desired amount to be removed:

$c = .050 \times 3.8667$

$c = .193$

First Pass Depth $.580 - .193 = .387 + .375 = .762$

Second Pass Depth $.762 - .193 = .569$

Third Pass Depth $.569 - .193 = .376$

Counterbore Set-up

1. Remove the tooling from the slides. Clean, then place the tooling in a secure location.
2. Remove the front cap from the bevel slide only.
3. Attach the counterbore slide using the four 5/16" SHCS to the bevel slide.



Figure 5-63. Attach the counterbore slide.

4. Secure the final 5/16" SHCS on the side of the bevel slide to complete installation.



Figure 5-64. Secure the SHCS on the side of the bevel slide.

5. Install the counterbore bit into the tool slot and secure with screws.



Figure 5-65. Install the counterbore tool into the slot.

Cutting the Counterbore

1. Feed the cutting tool into the pipe by turning the axial feed handle counter clockwise until the flat of the tool is inside the pipe face.

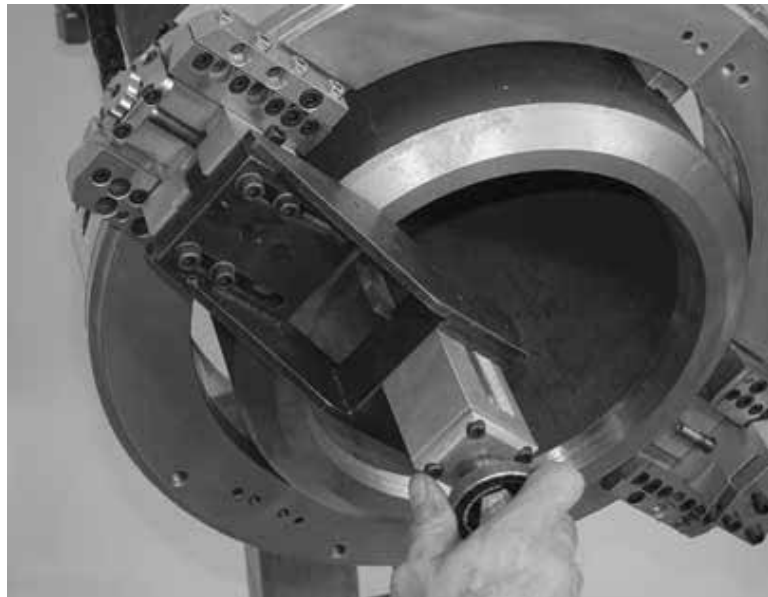

Figure 5-66. Turn the feed handle counter-clockwise

2. Turn the radial feed handle counterclockwise until the cutting tool lightly touches the pipe wall.

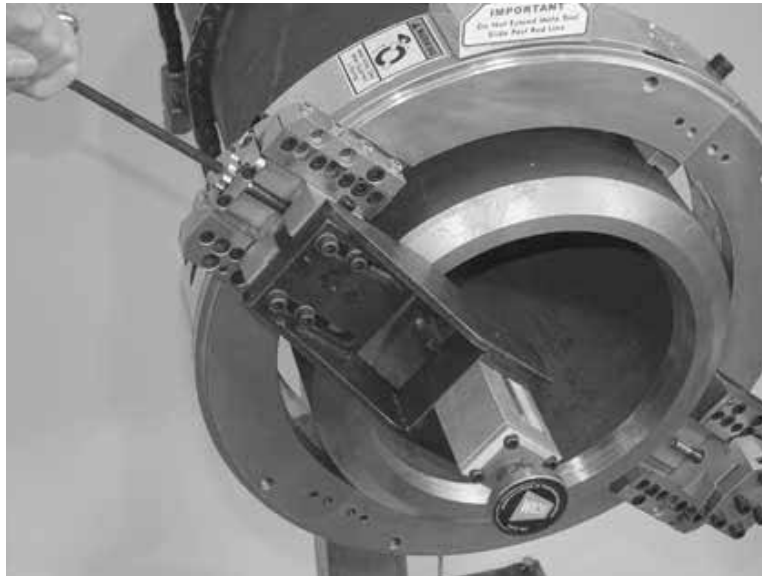

Figure 5-67. Turn the radial feed handle until the tool lightly touches the pipe

3. Adjust the counterbore slide for the first cut by turning the radial toolslide feed screw clockwise (each revolution is .0312”).



NOTE

Turn the axial feed knob clockwise to move the tool away from the pipe face.



Figure 5-68. Adjust the counterbore slide by turning the radial feed screw clockwise



Figure 5-69. Axial (.0312) and radial (.0784) adjustment per revolution

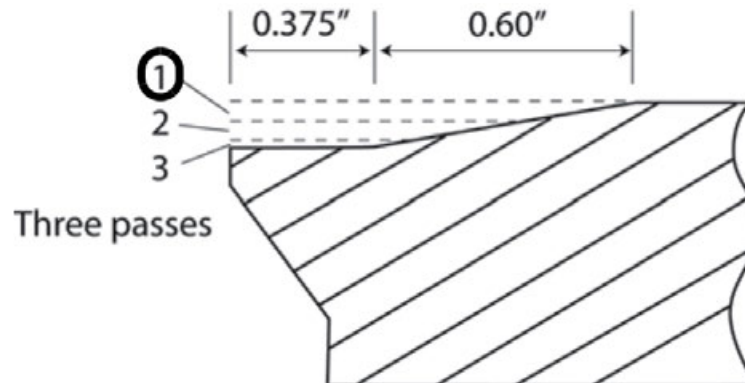

Figure 5-70. First pass of the counterbore tool

4. Engage air motor and set the speed at approximately 6 - 8 rpm.



NOTE

The incremental decal on the radial feed handle is not the radial feed depth indicator. Each line on the decal represents a .020" cut on the overall I.D.

5. Hold the axial feed handle as the machine rotates. This feeds the tool into the pipe.

6. Once the tool begins to cut, release the axial feed handle. Holding the feed handle for approximately 1/4 turn per revolution, will feed the tool into the pipe gradually. The longer the handle is held, the greater the feed rate.
7. Use the depth gauge on the support block monitor to observe the depth of the counterboring operation. As soon as the desired depth is reached, stop the machine.

	CAUTION
Cutting chips are VERY sharp. DO NOT touch them with bare hands. Serious injury could result.	

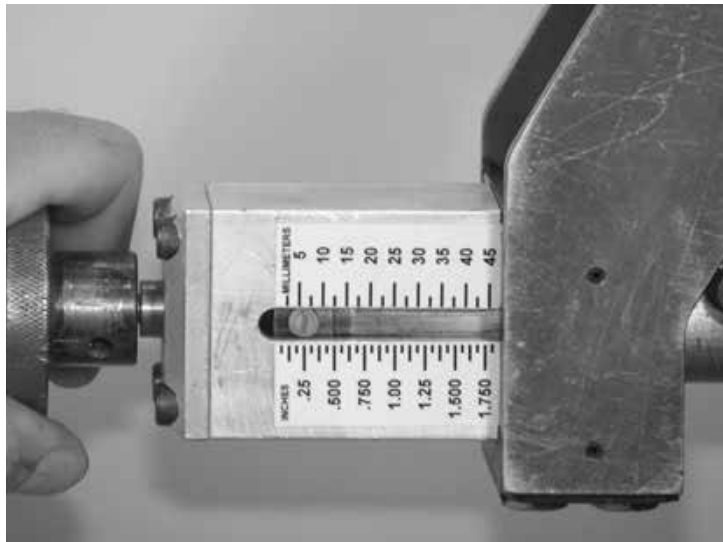

Figure 5-71. Depth gauge on the support block.

8. Measure the I.D. of the pipe. If the desired I.D. has been attained, remove the counterbore assembly. If the I.D. measurement required has not been achieved, repeat steps 3 - 9.

LCSF CUTTING ACCESSORIES

The following LCSF accessories are provided with their own user's manuals for setup and operation:

- Bridge Slide Accessory for Low Clearance Split Frame (manual part no. 60-MAN-03).
- Small LCSF O.D. Tracking Slide—for LCSF models 610 to 1420 (manual part no. 60-MAN-06).
- External-Internal Casing Cutter (EICC) (manual part no. 60-MAN-05).

REMOTE OPERATION WITH THE SF ACM

The split frame air control module (SF ACM) provides remote operation for E.H. Wachs split frame machines. The ACM is fully self-contained, requiring no power source other than compressed air. It is enclosed in a durable case that includes a handle and wheels for easy portability.

The SF ACM works with all LCSF and SDSF pneumatic drives:

- adapter 90-302-02 is required to operate the LCSF
- adapter 90-302-01 is required to operate the SDSF.

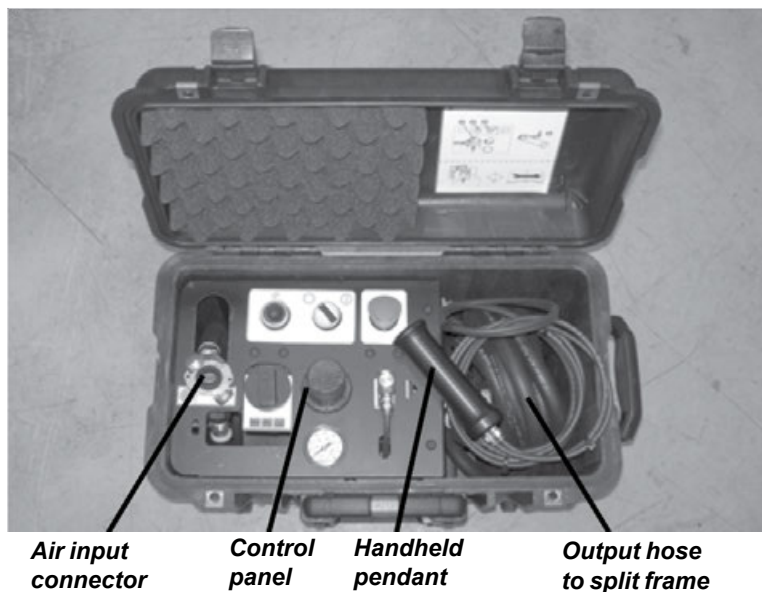

Figure 5-72. The photo shows the major components of the SF ACM. The case includes wheels and a retractable handle for easy transport.

Connectors

Input	1/2" female NPT (1/2-18 NPT per ANSI B1.20.1). Install appropriate fitting for your air supply.
Output	Quick disconnect to air motor fitting, provided (part no. 90-302-01 for SDSF; part no. 90-302-02 for LCSF).

Control Panel Reference

Figure 5-73 illustrates and describes the features of the ACM control panel.

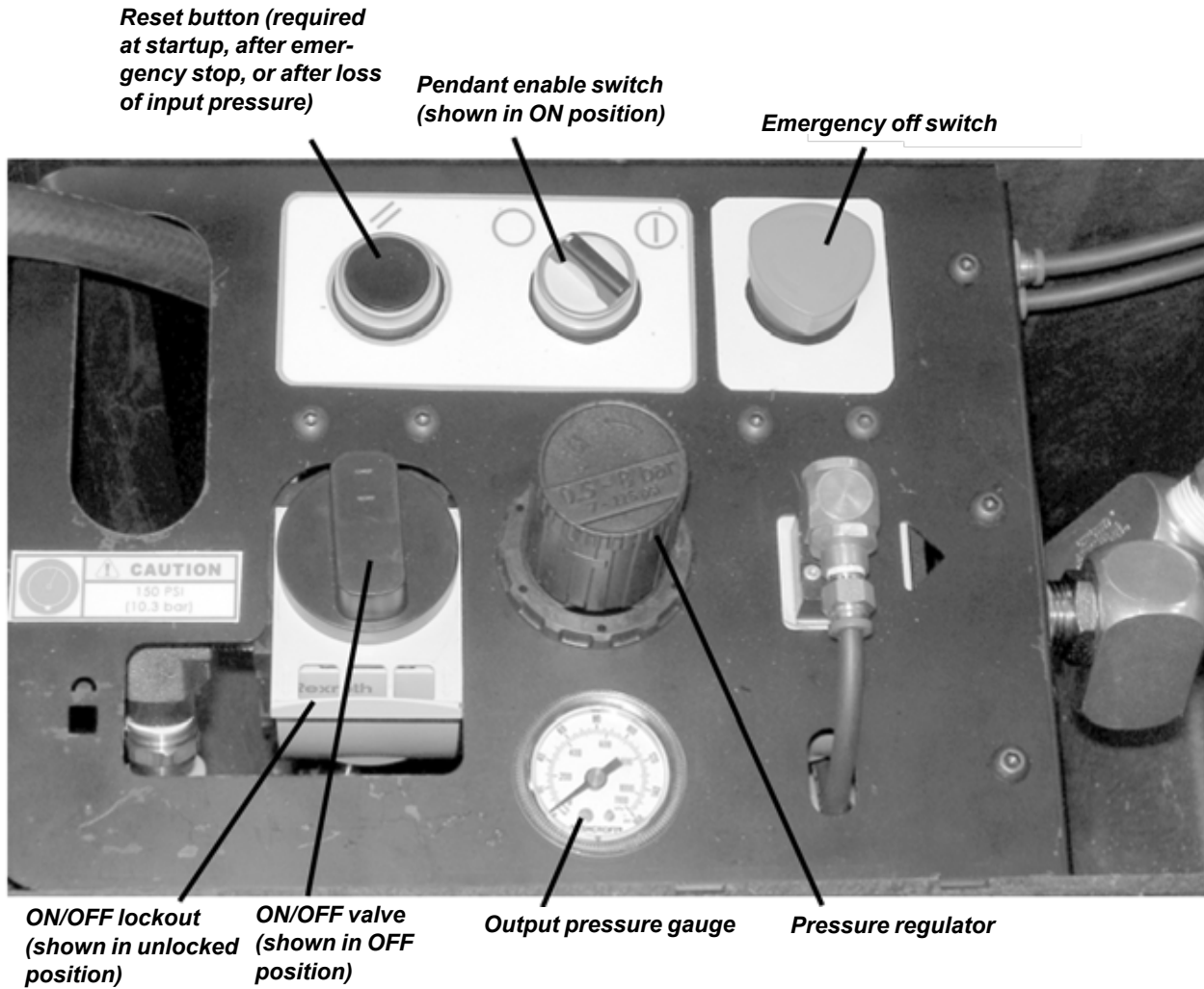

Figure 5-73. The photo illustrates the ACM controls.

Locating the ACM at the Worksite

Before you connect the ACM, decide where you will locate it for operating the split frame machine.

- The ACM has a 15 ft (4.6 m) output hose, allowing you to locate it up to 15 ft from the split frame.
- The ACM remote pendant has a 6 ft (1.8 m) hose. You must stand within this distance of the ACM while operating the split frame, so that you have ready access to the controls and emergency stop.



Figure 5-74. Position the ACM at a convenient distance from the split frame machine.

Operating the ACM

Before connecting the ACM, mount the split frame machine on the workpiece as described in the machine's user manual. Set up the machine so that it is ready to operate, and install the air drive on the machine.



NOTE

An instruction sticker for setting up and operating the ACM is attached to the inside of the case lid.

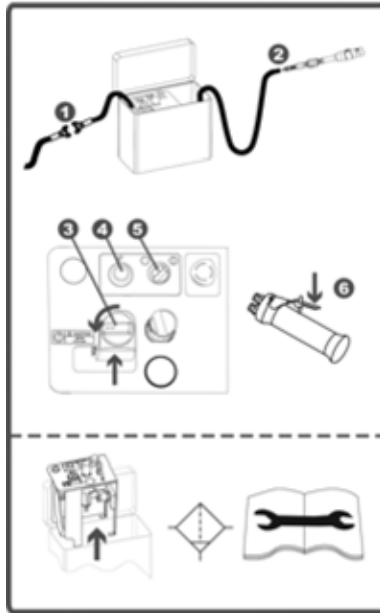

ACM Operation Sticker (part no. 60-1296-00).

The air drive must be configured to be “always on” for use with the ACM. See “Configuring the Air Drive for the ACM” on page 117.

Before connecting the ACM, the control panel should be in the pre-operation state, as shown in Figure 5-75.



Figure 5-75. The ACM controls should be in the pre-operation state, as shown, before connecting the air lines.

1. Make sure the air supply is turned off at the source.



NOTE

The ACM is supplied with a female 1/2" NPT fitting on the input connector. Install an appropriate coupling for your air supply line.

2. Attach the air supply line to the input connector of the ACM.



Figure 5-76. Connect the line from the air source to the input connector on the ACM.

3. Remove the output hose and control pendant from the case. Connect the output hose to the air drive connector on the split frame machine.

4. Align the air motor and route all hoses so that the hoses do not come in contact with any moving parts.



CAUTION

Do not allow the hoses to contact moving parts. This could damage the hoses or components of the split frame.

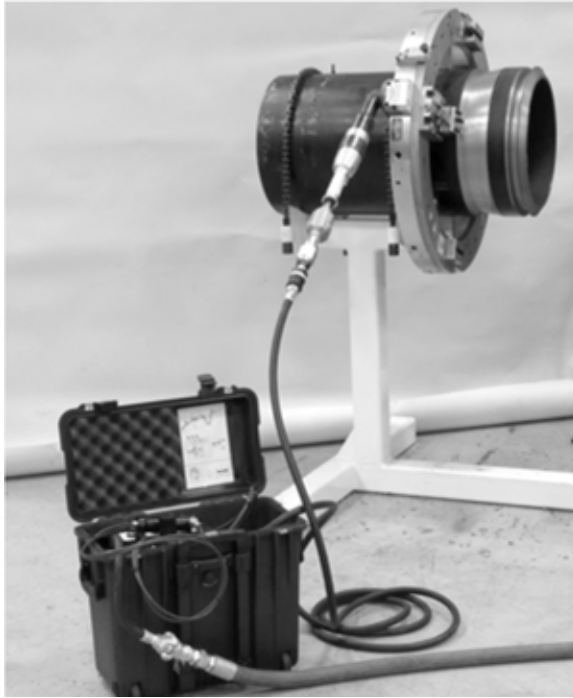

Figure 5-77. Route the hoses so they do not touch moving parts of the split frame.

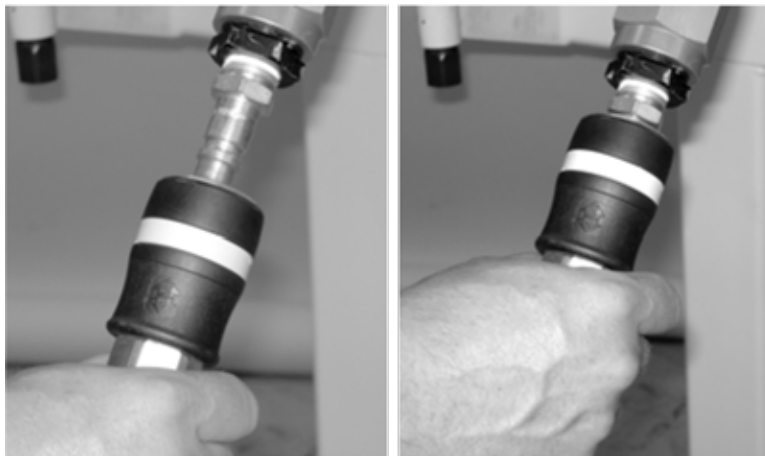

Figure 5-78. Connect the ACM output hose to the air motor fitting.



NOTE

The quick disconnect on the ACM output hose requires a specific fitting on the air motor. This fitting is provided with the ACM (90-302-01 for SDSF; 90-302-02 for LCSF).

5. Turn on the air supply at the source.
6. Make sure the emergency stop button on the control panel is pulled out.
7. Push in the lock-out tab on the ON/OFF valve.

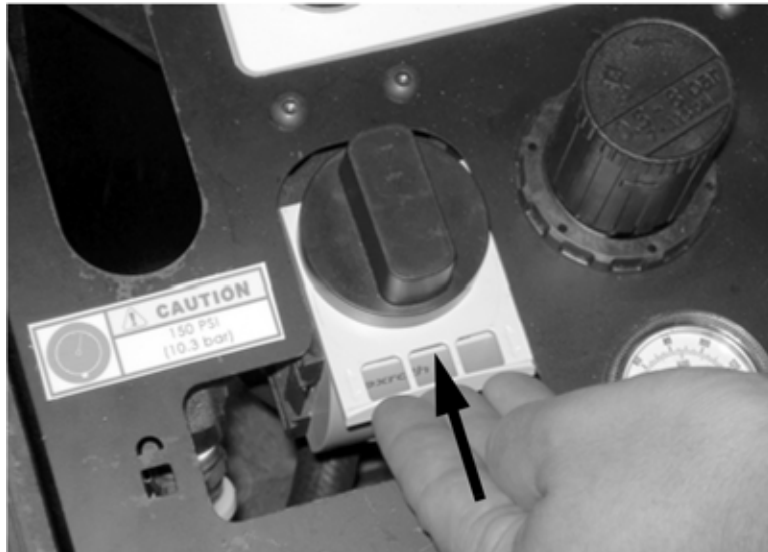

Figure 5-79. Press in the lock-out tab to enable the ON/OFF valve.

8. Turn the ON/OFF valve counter-clockwise to the ON position.

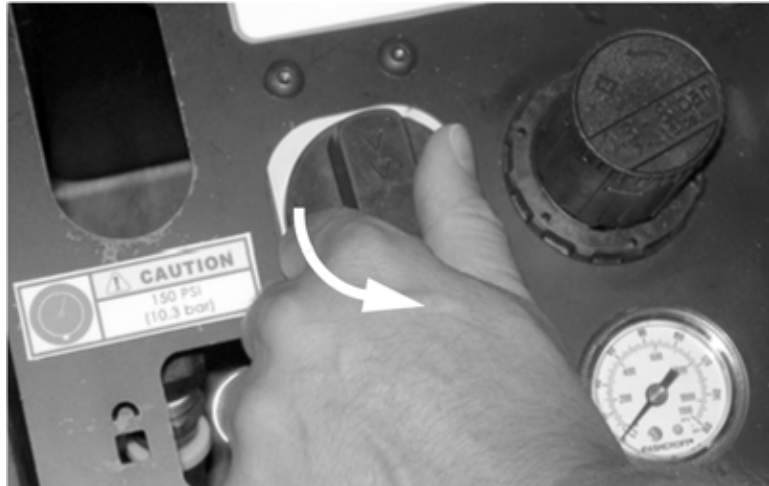

Figure 5-80. Turn the ON/OFF valve counter-clockwise to the ON position (shown in OFF position).

9. Press the Reset button on the control panel.



NOTE

You do not need to press Reset every time you restart the machine. Reset is required only after loss of supply pressure or an emergency stop.



Figure 5-81. The Reset button resets the ACM after a loss of pressure or an emergency stop.

10. Turn the Remote Enable switch to the ON position.



Figure 5-82. Turn the Remote Enable switch on to allow operation using the handheld pendant.

11. The handheld pendant will now operate the split frame machine.



CAUTION

Keep the pendant and its hoses away from moving parts. Allowing hoses to contact the equipment could damage them.



Figure 5-83. Squeeze the trigger on the handheld pendant to operate the machine.

Adjusting the Output Pressure

Use the pressure regulator on the control panel to adjust the output pressure to 90 psi (6.2 bar).



NOTE

The maximum output pressure is 116 psi (8.0 bar).

1. Pull the knob up and turn it to adjust the pressure.
 - To **increase** pressure, turn it **clockwise**.
 - To **decrease** pressure, turn it **counter-clockwise**.

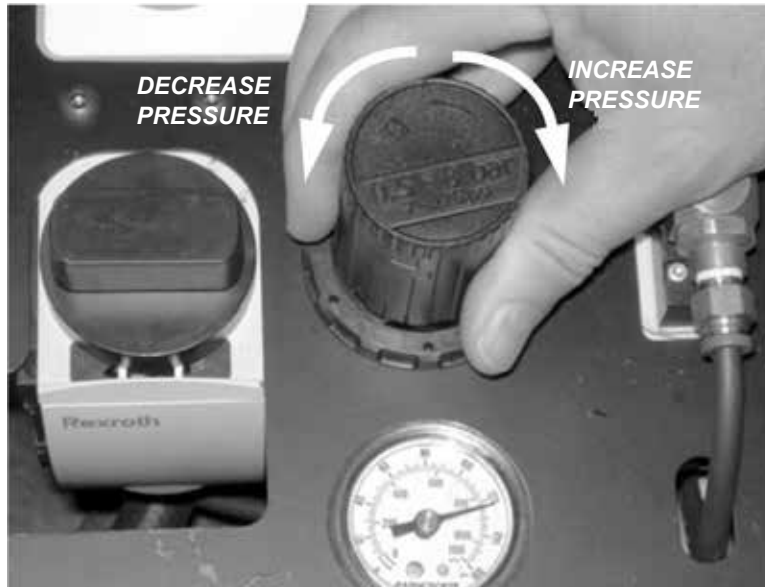

Figure 5-84. Pull up on the pressure knob and turn it to adjust the pressure.

2. To lock the pressure regulator so that it can't be adjusted, turn the knob (without pulling it) to expose the lock tabs. You can install a lock on the tabs.

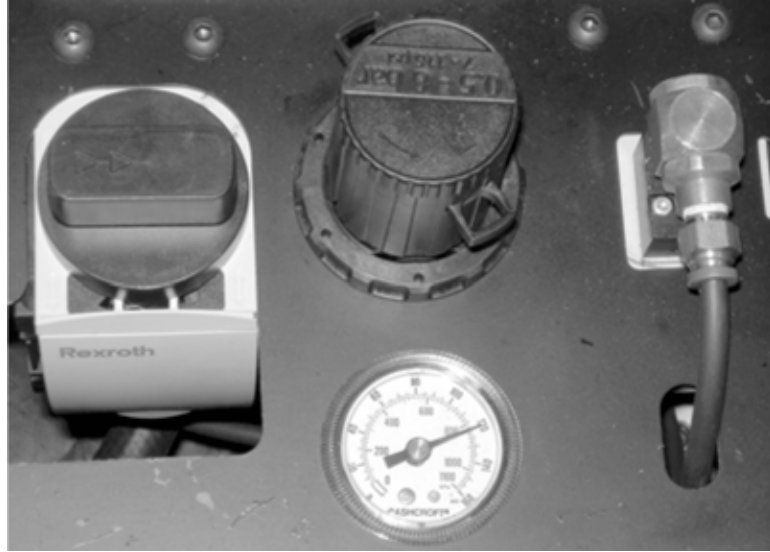

Figure 5-85. Without pulling the pressure knob, you can turn it to expose the lock tabs. Put a lock through the tab to prevent the pressure from being adjusted.

Using the Venting Quick Disconnect

A venting quick disconnect is provided on the air line that connects to the air drive of the split frame machine. This disconnect offers two convenient features:

- A “release position” vents line pressure before you disconnect the air line from the drive.
- The connector closes when it is disconnected, preventing air flow from a loose air line.

Operate the venting quick disconnect as shown in the following figures.

- 1.** To connect the air line, push the disconnect onto the fitting until it clicks and locks in place.



Figure 5-86. Push the air line disconnect onto the air drive fitting until it locks in place.

- 2.** To release the air line, first pull the collar back to the release position. The disconnect will come partly off the fitting and the line pressure is released.



NOTE

A symbol on the disconnect shows the steps to remove it from the fitting.



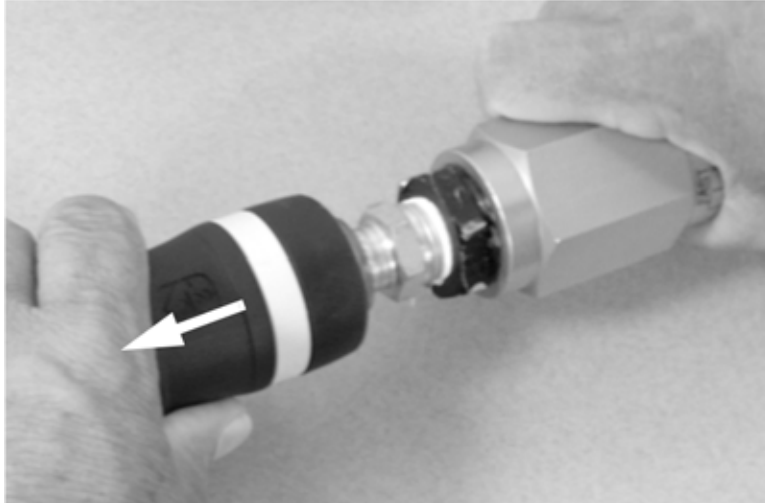

Figure 5-87. To release the disconnect, pull the collar back. The disconnect will snap back to the release position. (This will vent air in the air line.)

- 3.** To fully remove the air line, press the collar forward and pull the disconnect off the fitting.

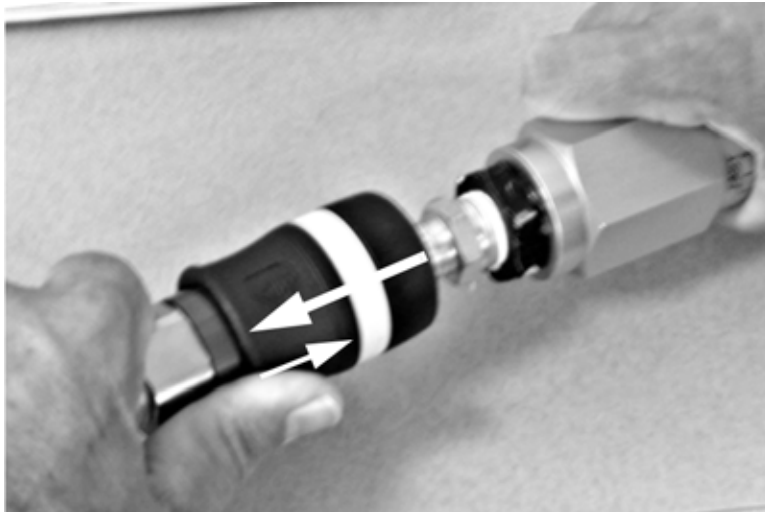

Figure 5-88. Push the collar forward and pull the disconnect to remove it from the fitting.

Configuring the Air Drive for the ACM

Air Fitting

The quick disconnect on the ACM output hose requires a specific air nipple fitting on the air motor. This nipple is provided with the ACM (part no. 90-302-01 for the SDSF; part no. 90-302-02 for the LCSF). Remove the existing fitting on the air motor and install the replacement nipple.



Figure 5-89. Install the supplied nipple onto the air motor for use with the ACM.

Air Trigger Modification

For remote operation, the air drive on the split frame must be modified for an “always on” configuration. Two alternatives for this configuration are provided with the ACM:

- A trigger strap for temporary use.
- An “open throttle plate” for long-term or permanent use.

Both devices fully open the on/off valve on the air drive. *Use the air drive with these devices installed **only** when you are operating the split frame with the ACM.*

To use the trigger strap, wrap it around the air drive trigger, pull it tight through the buckle, and attach the Velcro.

Use the following procedure to install the open throttle plate.

- 1.** Disconnect the air supply from the air drive, and remove it from the split frame machine. Set it on a workbench or stable work surface.
- 2.** With a hammer or mallet and a punch, drive out the mounting pin holding the trigger to the air drive. Remove the trigger.

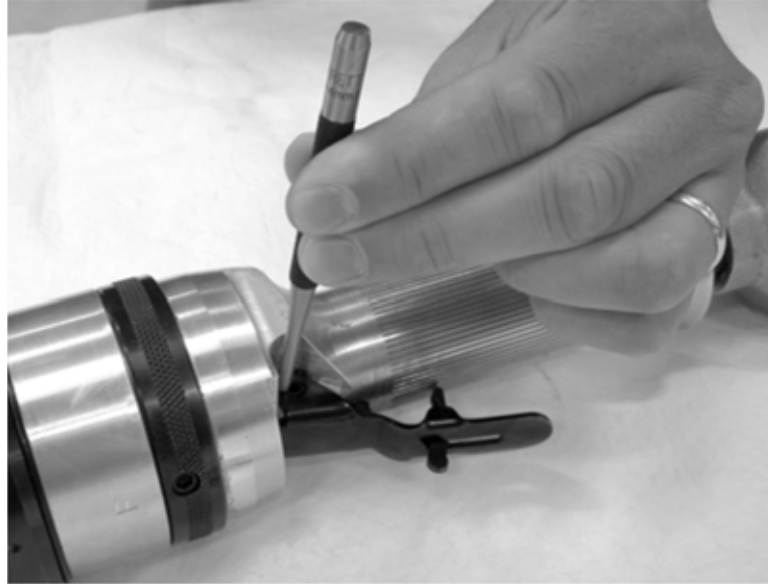

Figure 5-90. Use a punch to drive out the pin holding the air trigger.

- 3.** Put the open throttle plate in place at the trigger location, and insert the pin.

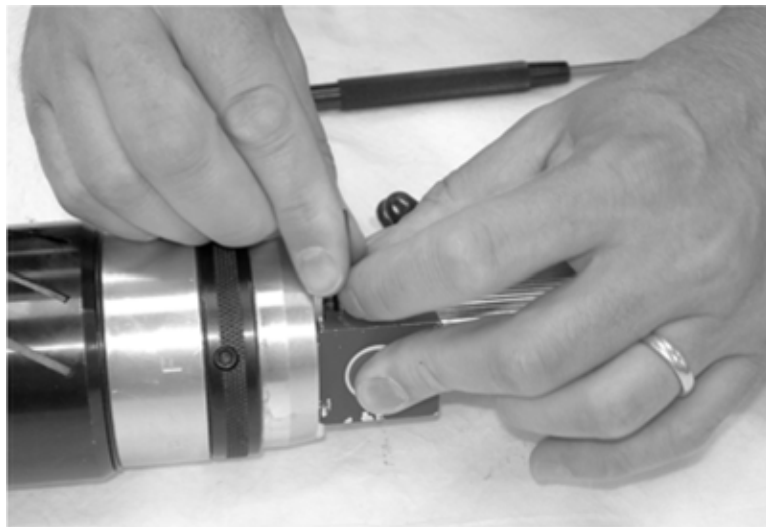

Figure 5-91. Attach the open throttle plate with the trigger pin.

- 4.** With the hammer and punch, drive in the pin until it is flush.

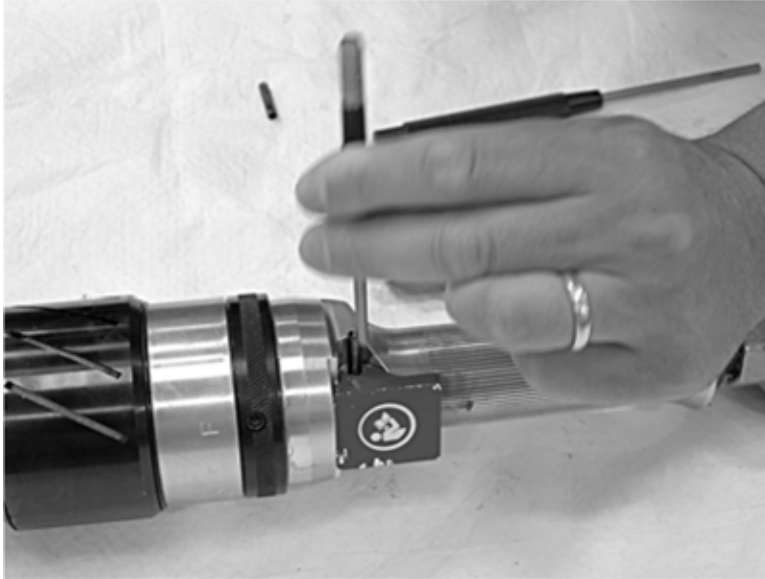

Figure 5-92. Drive in the pin to secure the open throttle plate.

5. The open throttle plate holds the air valve open on the motor.



CAUTION

When the open throttle plate is installed, do not connect the air drive directly to an air source. Use it only with the ACM. Turning on the air supply with the throttle open could cause damage or injury.



Figure 5-93. The photo shows the correct installation of the open throttle plate.

Chapter 6

Routine Maintenance

DAILY MAINTENANCE

After each use, clean debris from all moving parts, including the rotating ring and slide components. This will prolong the life of the machine, and prevent contamination of the storage/shipping case.

1. Use a brush or compressed air to remove loose debris from all sliding and rotating surfaces.
2. Neutralize any corrosive fluids that the machine may have come into contact with during operation, by wiping surfaces with a clean cloth sprayed with a household cleaning solvent.

LUBRICATION

Tool Slides

Lubricate all moving parts every 10 hours of operation. Use Mobil-lith AW-2 or equivalent.

Air Motor

An in-line oiler lubricates the air motor. You can adjust the drip rate of the oiler by turning the needle valve in the oiler using a flat screwdriver. Turn the screw counter-clockwise to increase the drip rate.



Figure 6-1. Use the needle valve screw to adjust the drip rate of the air motor oiler.



NOTE

The numbers on the dial do not indicate the number of drips per minute.

To check the drip rate of the oiler, run the air motor for one minute while holding a sheet of paper in front of the air outlet port. The paper should become stained with oil. If the paper is not oily, increase the drip rate on the oiler. If the paper becomes saturated or gets oily within a few seconds, decrease the drip rate.

As a general guideline, the standard LCSF air motor (1.5 HP) should use about 6-10 drops of oil per minute. The heavy-duty and reversible air motors (2.5 HP) should use about 8-12 drips per minute.

Recommended Air Motor Lubricants

Air Motor Grease Standard duty: NLGI Grade 2 grease (such as Chevron Black Pearl, CPS 24591)
High temperature: Amsoil Synthetic GVC or equivalent

Air Motor Oil Wachs air motor oil:
Pint (p/n 02-407-00)
Gallon (p/n 02-402-00)

Felt Wipers

Apply way oil to the felt wiper before storing the LCSF. Separate the ring halves and remove the rotating ring to access the felt wipers.

Felt wipers are installed in the stationary ring to clean and lubricate the raceway as the LCSF rotates. All LCSF models have two felt wipers, one in each section of the stationary ring. There are 3 sizes of wipers, used with the range of LCSF models:

- LCSF model 204 (4") uses wiper 60-1176-00.
- LCSF models 206-1420 (6"-20") use wiper 60-1178-00.
- LCSF models 1824-4248 (24"-48") use wiper 60-1181-00.



Figure 6-2. The photo shows the LCSF felt wipers.

Use the following procedure to access and service the felt wipers. Apply oil to the wipers every time you use the LCSF. Inspect them to see if they are worn, damaged, or excessively dirty, and replace them if necessary.

Note: Current LCSF machines have spring-loaded wiper brackets to keep the wiper in contact with the raceway. Some machines were supplied without spring-loaded brackets; if your LCSF does not have springs, you will need to adjust the wiper position when re-assembling the machine. See notes in the instructions below.

- 3.** Lay the LCSF on a workbench with the rotating ring up.
- 4.** Remove the slides and the pinion housing.
- 5.** Rotate the machine to align the split lines on the stationary and rotating rings. Insert the frame locking pins.
- 6.** Separate the machine at the split lines. Refer to the instructions in the LCSF User's Manual.
- 7.** To access the felt wipers, remove the frame locking pins and turn the rotating ring out of the stationary ring until you can see the wiper.



Figure 6-3. Turn the rotating ring out of the stationary ring far enough to access the wipers.

- 8.** Remove the wiper from the bracket and inspect it for wear, damage or buildup of debris.



Figure 6-4. Inspect the wiper for wear, damage, or debris.

- You can clean debris from the wiper with compressed air. If there is debris such as metal chips embedded in the wiper, replace it.

- Check the contact edge of the wiper for wear. If the corners are worn off or the wiper is deformed, replace it.
 - Some dirt and discoloration on the wiper is normal. If it is extremely dirty, and the dirt affects the consistency of the fabric, replace the wiper.
- 9.** Replace the wiper in the bracket. Make sure the notched edge of the wiper is down (toward the stationary ring).

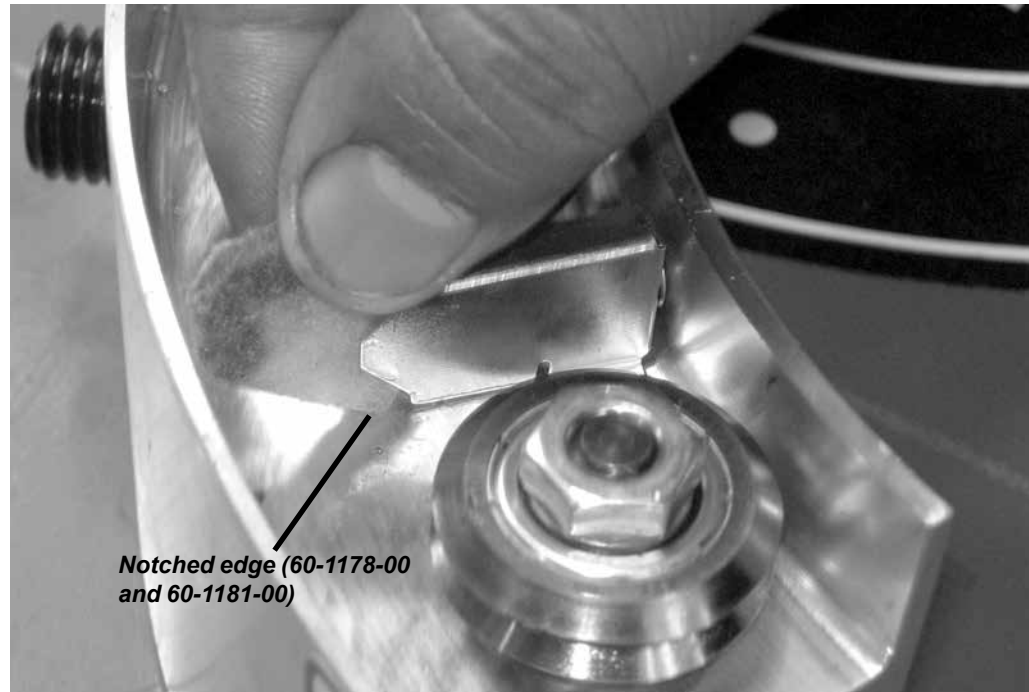

Figure 6-5. Replace the wiper in the bracket, with the notched edge down.

- 10.** Apply two drops of way oil directly to the wiper. (Way oil available from E.H. Wachs, part no. 60-1184-00.)
- 11.** Turn the rotating ring back, pushing the wiper into the bracket to fit inside the raceway.



Figure 6-6. Push the wiper into the bracket and turn the rotating ring into position.

- 12. NOTE:** If your LCSF does not have spring-loaded wiper brackets, adjust the position of the wiper so that it is in firm contact with the raceway when you turn the rotating ring back into the stationary ring.

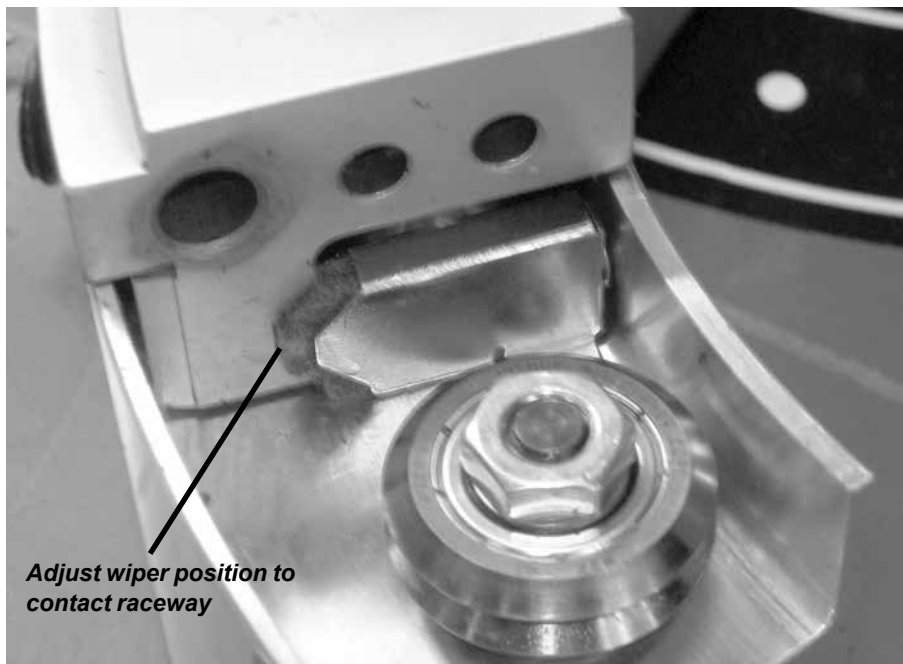

Figure 6-7. For machines without spring-loaded wiper brackets, make sure the wiper is in contact with the raceway. Adjust the wiper position if necessary.

SERVICING THE SF ACM

After each use, check for water in the bottom of the ACM case. The ACM includes a draining filter that can release a small amount of water during operation. Lift the control panel out of the case and pour out any water that has accumulated. Wipe the case dry and replace the control panel.



CAUTION

Remove the control panel from the case before tipping it. The panel is not fastened in the case and can fall out if you turn the case over



NOTE

Remove the output hose and control pendant before lifting the control panel out of the case.

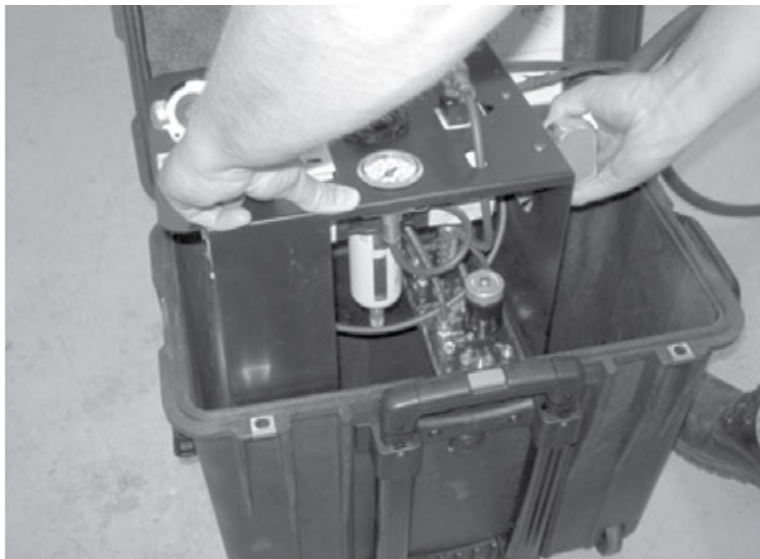

Figure 6-8. Lift the control panel out of the case for service or to drain out accumulated water.

The filter should be checked periodically. The filter is accessible when you have the control panel out of the case. To remove the filter, pull the locking tab down and turn the filter to the left.



NOTE

The 5 micron filter element is available from E.H. Wachs or from the manufacturer (Rexroth, part no. 1829207068).

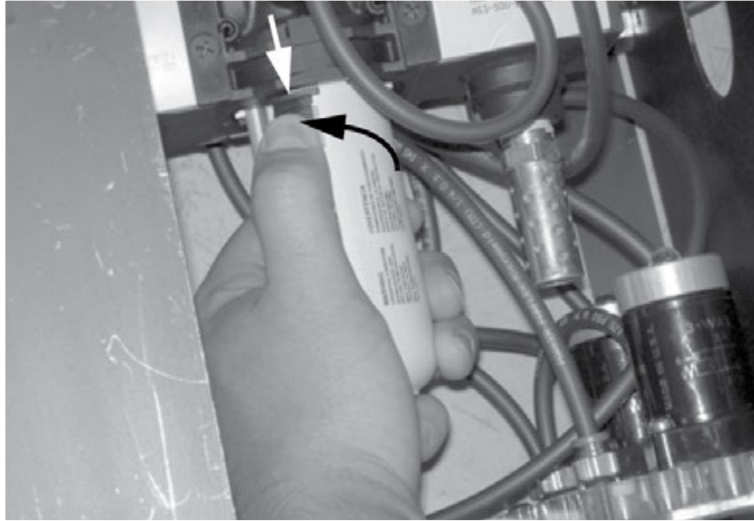

Figure 6-9. To remove the filter, pull the locking tab down with your thumb and turn the filter to the left.

Chapter 7

Service and Repair

TROUBLESHOOTING

Trouble	Possible Cause	Remedy
Machine won't run	Detent pins not removed	Remove pins
	Power supply not on	Check power supply
	Improper bearing preload	Refer to maintenance for adjustment
Machine runs slowly	Improper speed or gear box setting	Turn throttle on the motor
	p.s.i. not correct	Needs 80 - 100 p.s.i.
Tool slide does not feed	Trip pin not engaged	Engage trip pin
	Trip pin assembly in wrong position	Add or remove spacers
	Stripped feed screw or nut	Replace part or add dovetail
Tool penetration causes tool to bind	Improper tool slide adjustment	Readjust tool slide
	Worn feed screw / feed nut	Replace feed screw / feed nut
	Tool bit is dull	Replace bit
Machine moves during cut	Loose clamp pads	Tighten clamp pads
Machine chatters during cut	Speed control too fast	Reduce speed
	Tool bit is dull	Replace bit
	Improper ring adjustment	Readjust ring
Poor cutting quality	Tool bit is dull	Replace bit
	Improper tool installation	Reinstall bit

ADJUSTING THE BEARINGS

LCSF Machines with Fixed Bearings (2009 and Later)

LCSF machines manufactured since 2009 have fixed reference bearings for improved bearing adjustment. (Machines manufactured before 2009 have a different bearing adjustment procedure; see the instructions in the LCSF User Manual.)

If you are not sure if your machine has fixed bearings, take off the bearing cap at one of the fixed bearing positions. Fixed bearings do not have a hex end for turning the eccentric. The figures below shows the positions of the fixed bearings on the LCSF models noted in the captions.

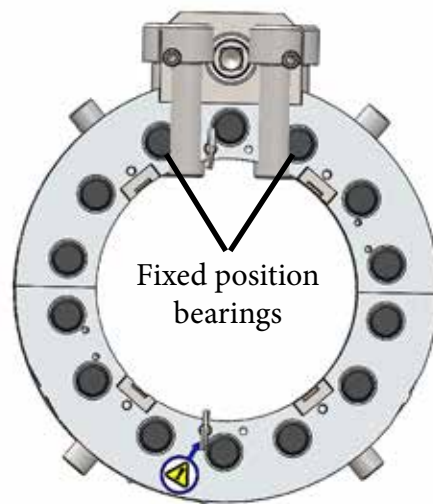

Figure 7-1. The drawing shows the positions of the fixed bearings for LCSF models 204 and 206 (4" and 6").

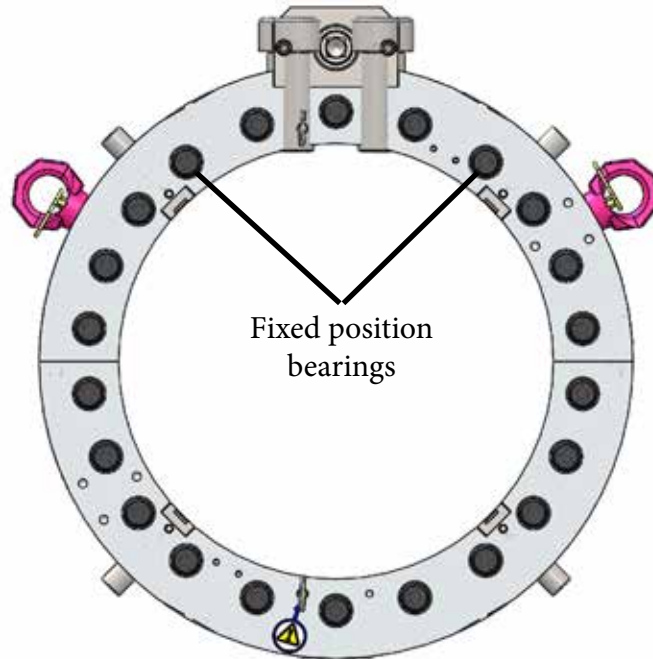

Figure 7-2. The drawing shows the positions of the fixed bearings for LCSF models 408-1420 (8" through 20").

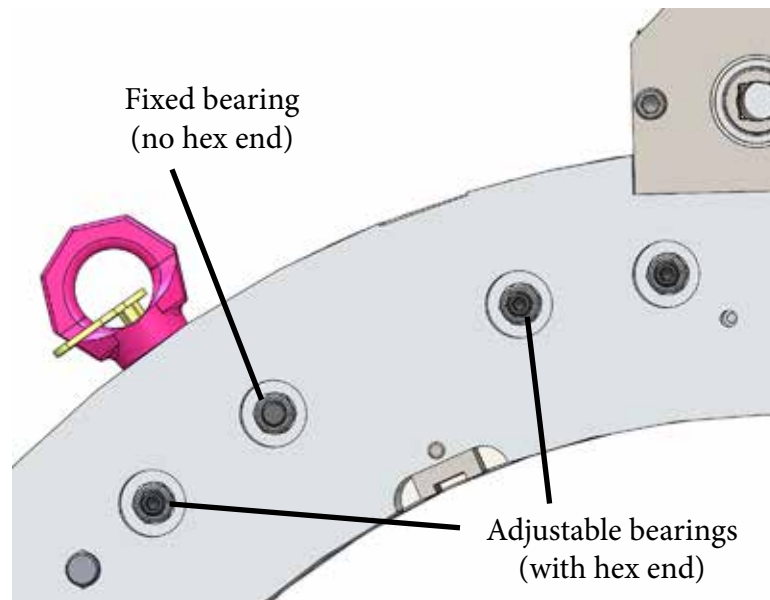

Figure 7-3. To check if your LCSF machine has the fixed-bearing design, remove the bearing caps at the fixed bearing positions. If the shaft has no hex in it, as shown, it is a fixed bearing.



NOTE

Remove the pinion housing assembly and tool slides **before** beginning bearing adjustment.

Required tools:

- 3/16" hex wrench
- 9/16" socket wrench
- Alignment pins (60-098-00)
- Bearing adjustment wrench (60-089-00)



NOTE

If you are installing new guide wheel bearings, assemble the bearings, eccentric shafts, and bearing spacers to the stationary ring. Tighten the 3/8-16 nylock hex nut enough to allow eccentric shafts to rotate smoothly.

- 1. To prepare existing guide wheel bearings for adjustment procedure,** loosen the 3/8-16 Nylock hex nut only enough to allow eccentric shafts to rotate smoothly. Make a mark on the edge of each bearing with a permanent marker. These marks will help you check that the bearings are turning later in this procedure.



Figure 7-4. Mark the edge of each bearing.

- 2. Rotate all eccentric shafts to position the guide wheel bearings toward the inside of the stationary ring.**



Figure 7-5. Rotate the eccentric shafts so that the high point of each bearing faces the inside of the ring.

- 3.** Slide the rotating ring into the stationary ring, then repeat with the other half of the machine.

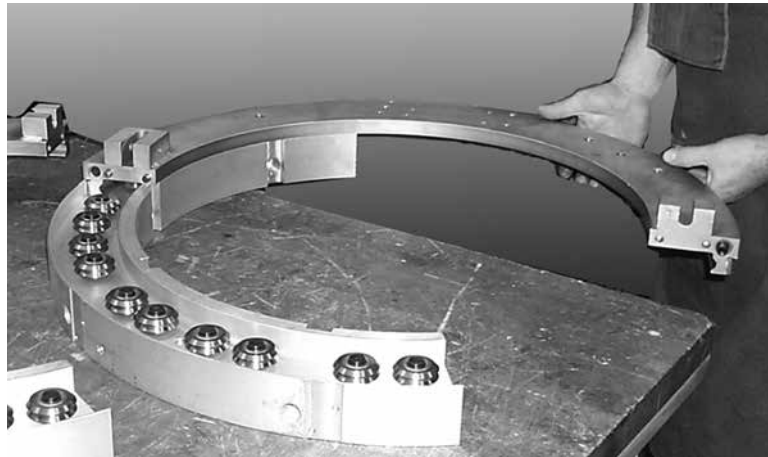

Figure 7-6. Slide rotating ring into stationary ring.

- 4.** Assemble the ring halves, tightening the captivated screws of the stationary ring first.

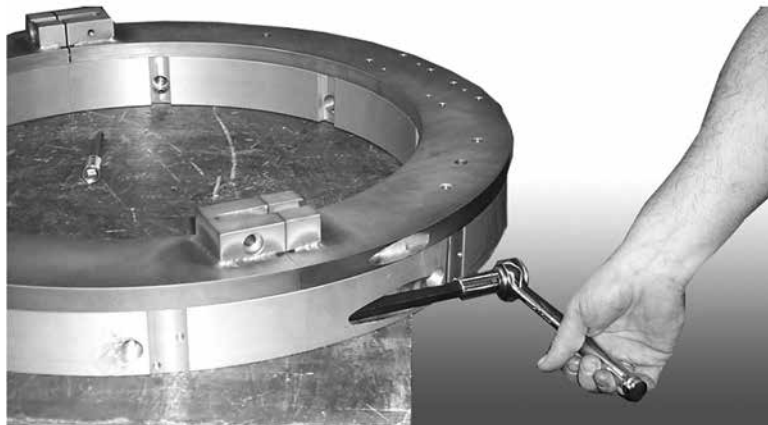

Figure 7-7. Assemble the ring halves and tighten the captivated screws.



CAUTION

Use a crane or other lifting device to lift the LCSF. There is a risk of injury from lifting the machine, or from setting or dropping it on hands or feet.

5. Position the machine with the rotating ring face down on the workbench and check for free play between the rotating and stationary rings. (The stationary ring should “wobble” on the rotating ring.) Disassemble the machine and repeat Step 2 if play is not felt.

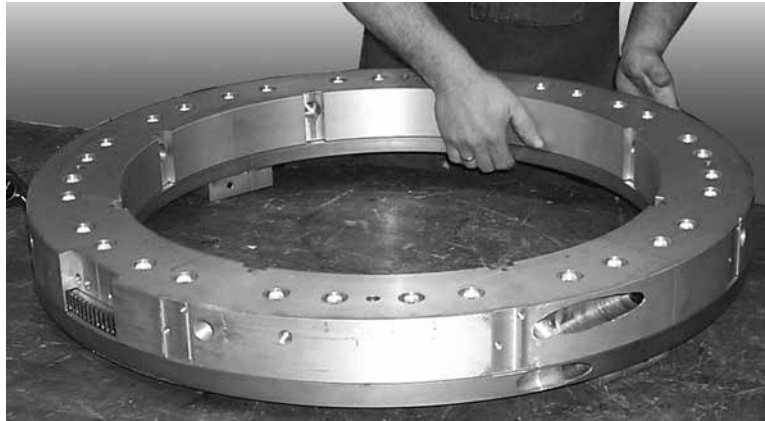

Figure 7-8. Check for play between the rotating and stationary rings.

6. **Do not** insert the alignment pins.
7. Starting at position #1 shown in the figures below, turn the eccentric shaft counter-clockwise until you feel the bearing just touch the groove. Tighten the 9/16 nylock hex nut.

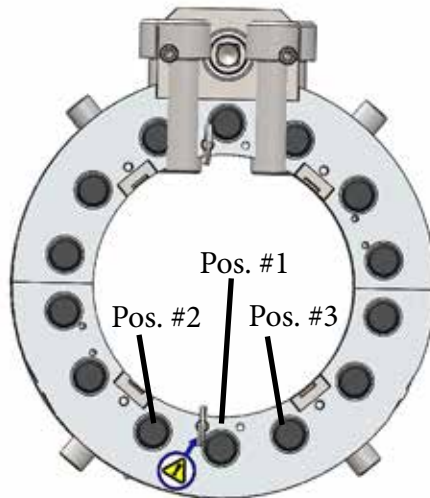

Figure 7-9. Adjust the bearings in the order shown, then work around the machine toward the pinion, alternating side to side. (Models 204-206.)

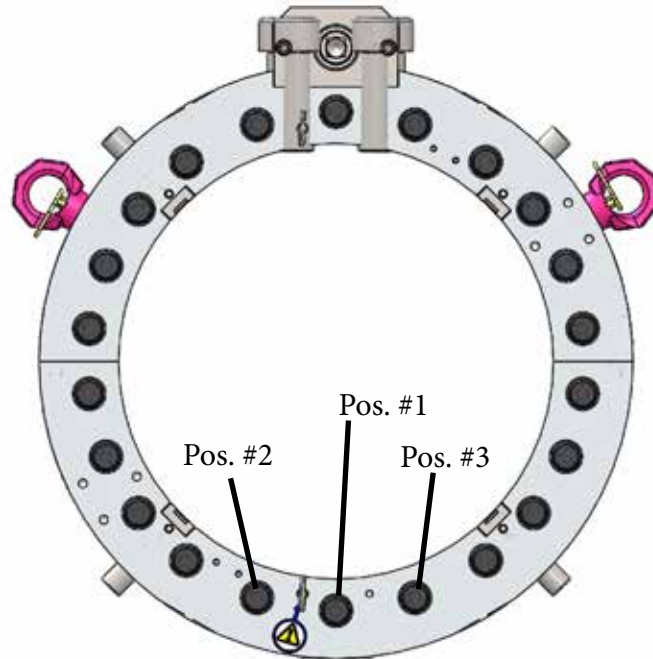

Figure 7-10. Adjust the bearings in the order shown, then work around the machine toward the pinion, alternating side to side. (Models 408-1420.)

8. Adjust the bearing at position #2 in the same way.
9. Continue to adjust the bearings around the ring, alternating side to side. Finish with the bearings below the pinion, between the fixed bearings.
10. Rotate the machine through at least one full revolution, looking through an alignment pin hole to check that all guide wheel bearings turn with the machine. (The marks you made earlier will help you see if the bearings are turning.)
 - You should be able to rotate the machine by hand. If you cannot, repeat the entire adjustment procedure.
 - The machine should rotate smoothly, with no sticking points. If it sticks or catches at any point, try to re-adjust the bearings at the split lines where the machine catches. If you cannot get it to operate smoothly with a slight adjustment, repeat the entire adjustment procedure.
 - If any adjustable bearing is not turning, try to adjust it again. If you cannot get it to turn with a slight adjustment, repeat the entire adjustment procedure.
 - If either of the fixed bearings is not turning, repeat the entire adjustment procedure.

Pre-2009 Machine (Without Fixed Reference Bearings)

The following procedure is for LCSFs with a serial number starting with **08** or less (08-XXXX), manufactured before 2009.

11. Remove any tool slides installed on the rotating ring.
12. Using a 1/4" hex wrench, split the LCSF. Remove the rotating ring from the stationary frame.

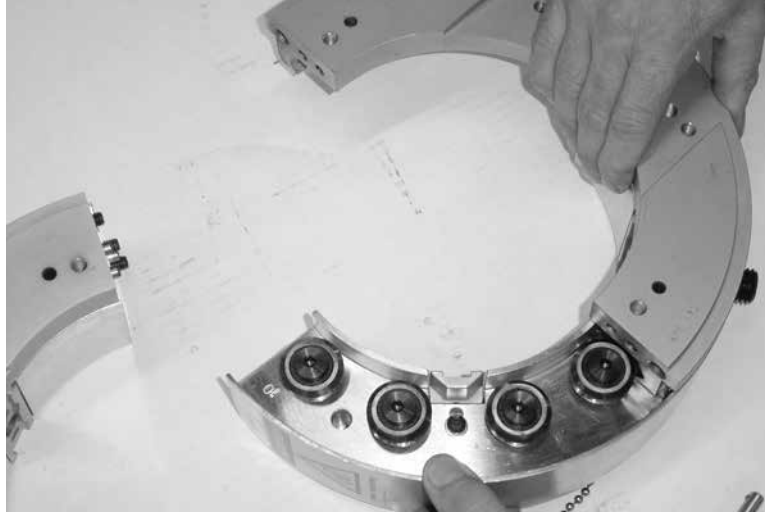

Figure 7-11. Separate the stationary and rotating rings.

- 13.** Clean out the area around the guide wheel bearings (37-005-00) in the stationary frame and the “V” groove area of the rotating ring.



Figure 7-12. Clean debris from the stationary ring.

- 14.** Inspect the “V” groove area of the rotating ring for deformation, cracking, and/or pitting. If the ring is damaged, you will need to replace it.

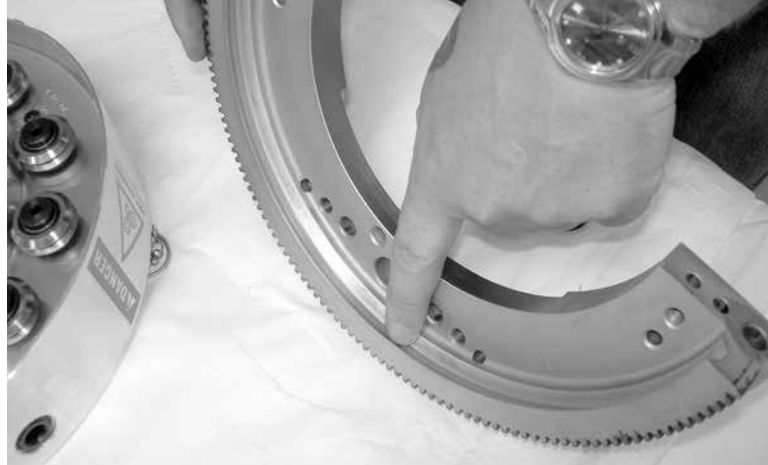

Figure 7-13. Inspect the “V” groove of the rotating ring for wear or damage.

15. Check to make sure each bearing spins freely by hand.
16. Remove the plastic caps on the back of the stationary ring and inspect the bearing assemblies. Replace any worn or broken components.



NOTE

Each bearing assembly consists of a bearing, a spacer, an eccentric shaft, a washer, and a lock nut). See assembly drawings in Chapter 8 for specific part numbers for your LCSF model.





Figure 7-14. Remove the plastic caps to inspect the bearing assemblies.

- 17.** Using a 1/2" socket wrench, break loose the 5/16"-18 lock nuts (90-065-03).



Figure 7-15. Loosen the lock nuts.

- 18.** Turn the eccentric shafts so that the lines on top of them point toward the frame center.



Figure 7-16. Set the marks on the eccentric shafts toward the center of the ring.

- 19.** Insert the rotating ring halves back into the stationary ring halves.
- 20.** Reassemble the machine halves using a 1/4" hex wrench.
- 21.** An optional **bearing fixture plate** (60-205-00) is available to make adjusting the bearings easier. Install the plate on the rotating ring at one of the slide mounting positions, using two (2) 5/16"-18 x 7/8" SHCS and a 1/4" hex wrench.

 **NOTE**

The bearing fixture plate keeps the eccentric shafts from turning as you tighten the bearing lock nuts. This keeps the guide wheel bearings within the “V” groove preload of 10-15 in-lb.

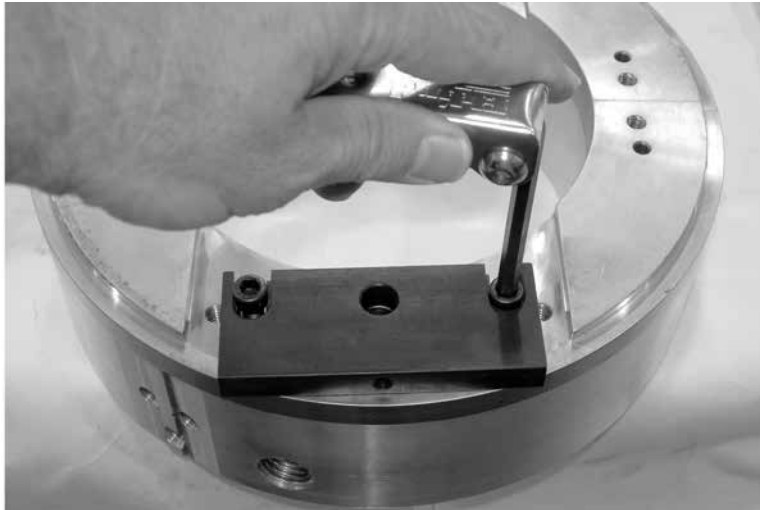

Figure 7-17. Install the bearing fixture plate on the rotating ring at the slide mounting position.

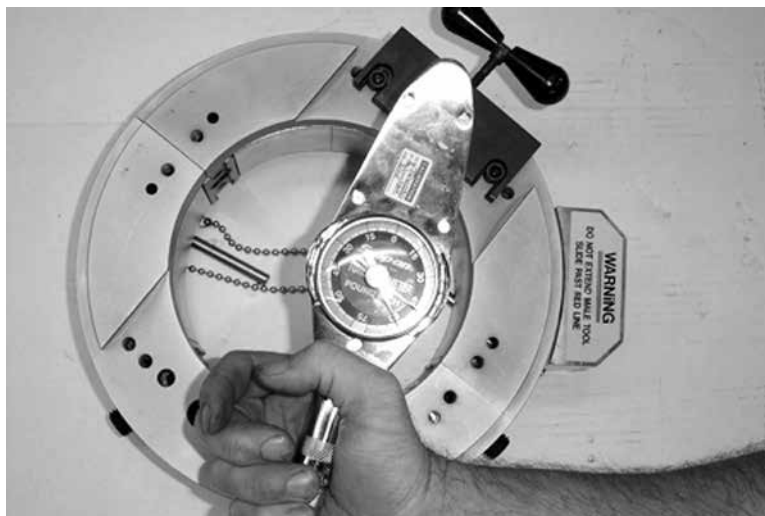

Figure 7-18. The fixture plate will hold the eccentric shaft as you set the bearing wheel against the “V” groove.

- 22. If you do not have the bearing fixture plate**, you will need to use a 3/16” hex wrench to hold the eccentric shaft. Since this is done while tightening the 5/16”-18 lock nut, you must be careful to keep adequate “V” groove preload (10-15 in-lb) on the eccentric shaft.

23. Refer to the Figure 7-9 for your LCSF model, and locate the #1 position eccentric shaft.

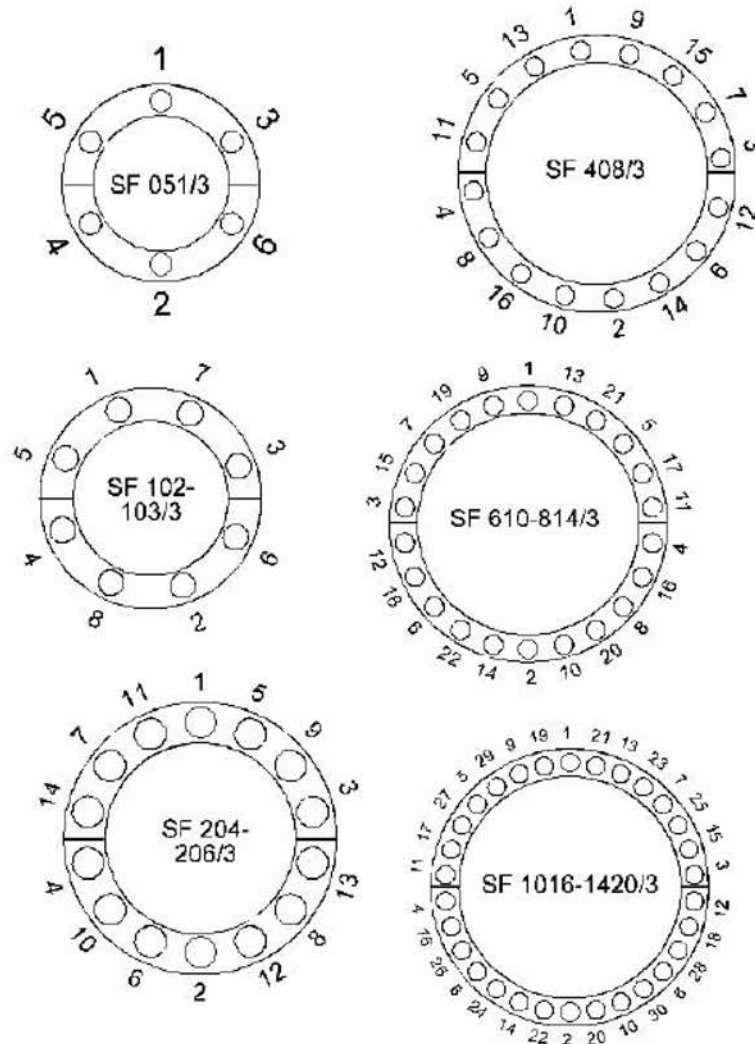

Figure 7-19. Bearing Adjustment Sequence Chart

- 24.** Turn the eccentric shaft counter-clockwise until the guide wheel bearing touches the rotating ring “V” groove. Torque 10-15 in-lb.
- 25.** Secure the eccentric shaft using the bearing fixture plate and tighten the lock nut to 150 in-lb.



Figure 7-20. Secure the eccentric shaft.

26. Repeat Steps 14 and 15 for the #2, #3, and #4 positions.
27. Check that the rotating ring is centered to the stationary frame using the supplied square. If not centered, repeat Steps 14 and 15.

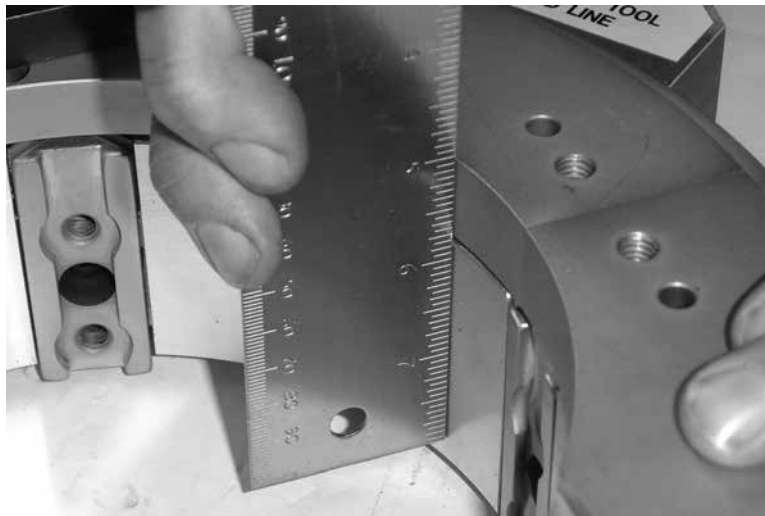

Figure 7-21. Center the rotating ring to the stationary frame.

28. Turn the rotating ring by hand around the stationary frame. The machine should turn smoothly and consistently. Check the backlash between the rotating ring and the pinion gear.
29. Repeat Steps 14 and 15 for the remaining bearings.
30. Check that all guide wheel bearings rotate while the machine turns. Look through the holes in the rotating ring while turning the machine.



Figure 7-22. Check for bearing rotation as you turn the rotating ring.

31. Turn the rotating ring by hand around the stationary ring. The machine should turn smoothly and consistently, and should stop immediately when you stop turning it. If it doesn't operate this way, repeat the bearing adjustment procedure.

TOOL SLIDE ADJUSTMENT

To check the tension on the tool slide, attempt to turn the starwheel at the front of the slide. It should be very difficult to turn with your bare hand, but you should be able to turn it by hand with a rag or some form of cushion.



NOTE

The star wheel should require approximately 15-17 in-lbs of torque to turn.

The slide tension is adjusted using four (4) set screws on the dovetail on one side of the slide. The dovetail “clamps” the male tool slide, and the screws adjust how tightly the dovetail holds the male slide.

Use the following procedure to completely reset the slide tension.

1. Loosen the four (4) 1/4-20 jam nuts and set screws on the side of the slide.

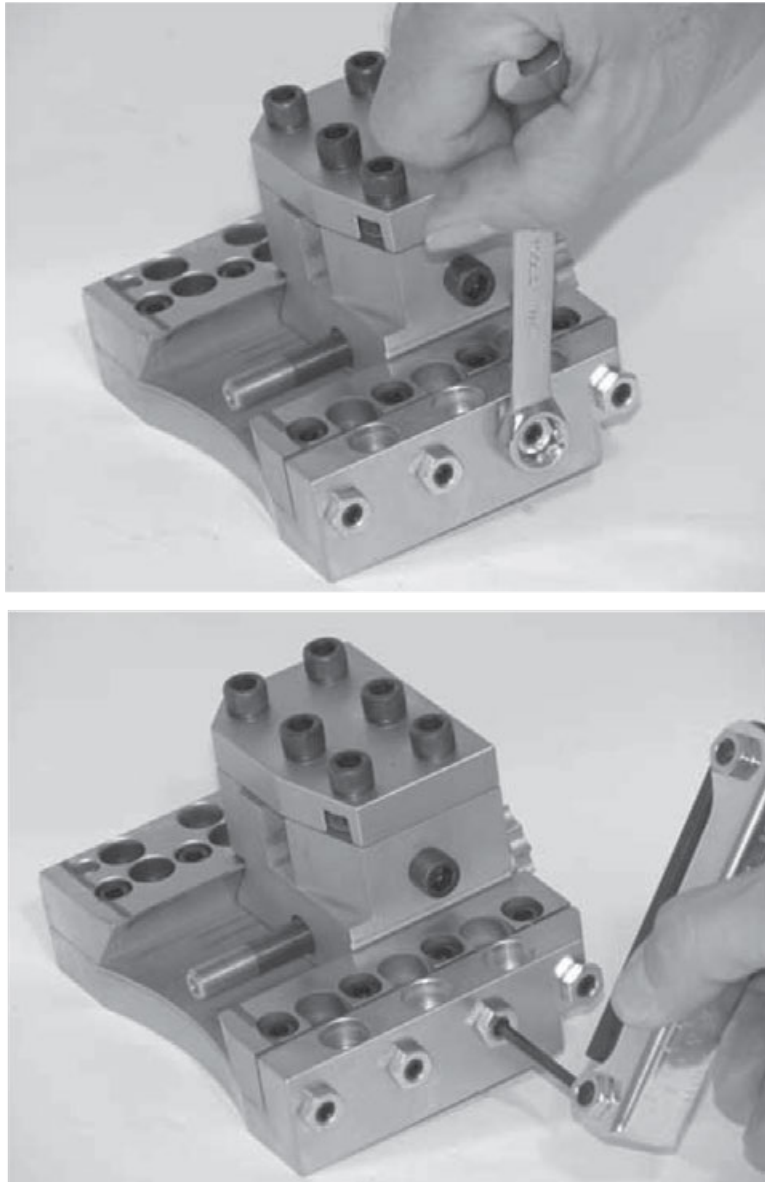

Figure 7-23. Loosen the jam nuts (top), then loosen the set screws (bottom).

2. Remove the four (4) 1/4-20 x 7/8" socket head cap screws from the adjustable dovetail.
3. Remove the four (4) 1/4-20" cap screws from the starwheel plate.
4. Clean the slide as best you can and apply a thin layer of grease on the face of the adjustable dovetail.

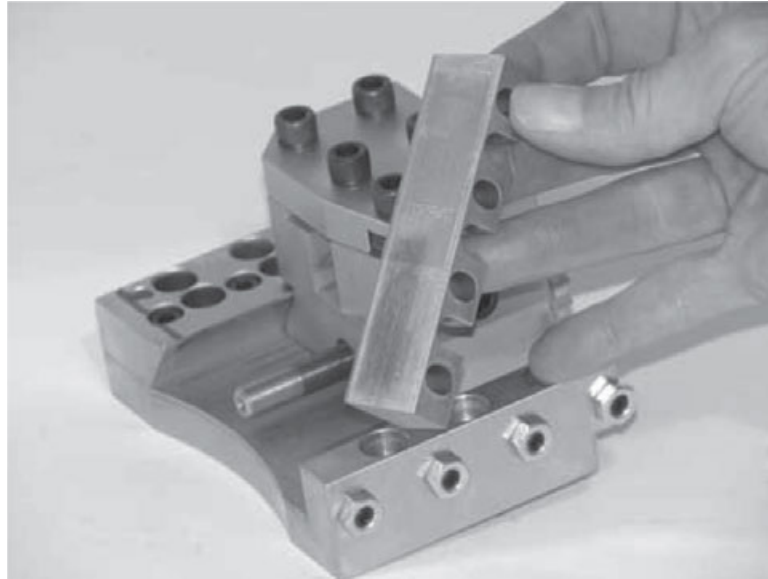

Figure 7-24. Remove the dovetail and clean the slide.

5. Turn the starwheel until the tool slide is in the central position.
6. Replace the adjustable dovetail and the four (4) 1/4-20 x 7/8" socket head cap screws.

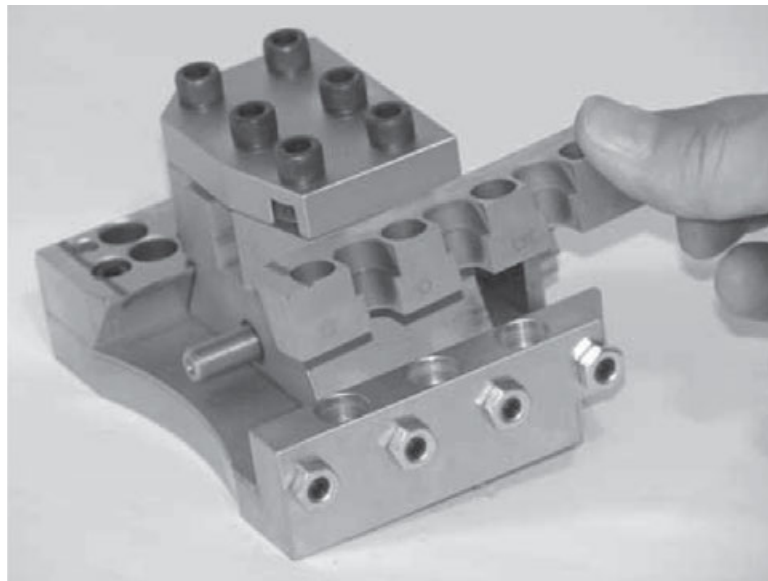

Figure 7-25. Replace the dovetail and SHCS.

7. Position the adjustable dovetail so that there is no gap between it and the slide base.
8. Tighten the 1/4-20 x 7/8" socket head cap screws so they are "snug". You do not want them to be fully tightened or the tension will not be set correctly.

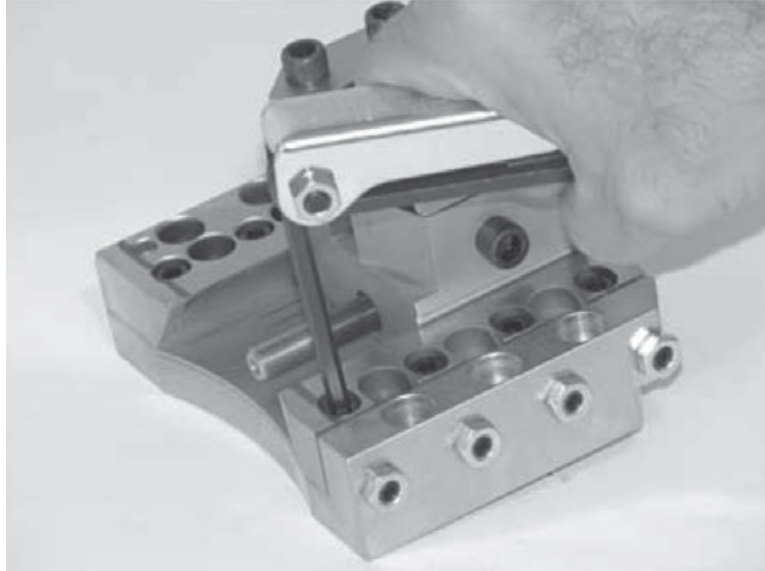

Figure 7-26. Tighten the SHCS until snug.

- 9.** Replace the center two (2) 1/4-20 set screws and tighten them until the adjustable dovetail is touching the tool slide.

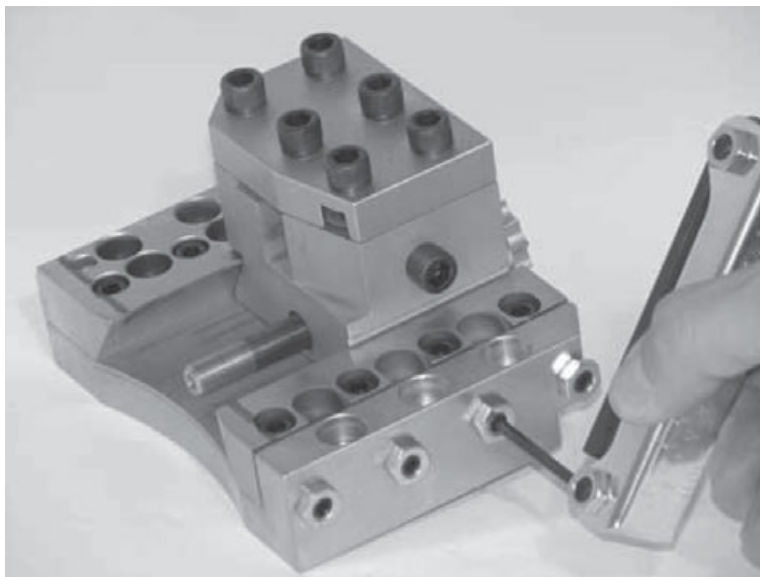

Figure 7-27. Replace the set screws and tighten.

- 10.** Make sure the dovetail stays as straight as possible.
- 11.** Tighten the 1/4-20 set screws and turn the star wheel at the same time until you feel tension in the star wheel. Try to keep the tension on the set screws as even as possible.

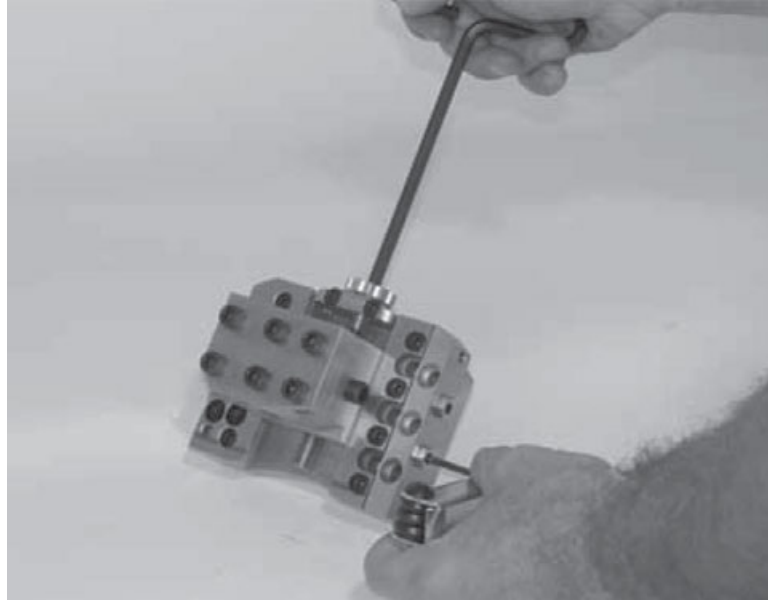

Figure 7-28. Tighten set screws while turning the star wheel.

12. Move the tool slide to the top and adjust the 1/4-20 set screw until you feel the same amount of tension as in the middle.
13. Repeat the process for the bottom of the slide.
14. Fully tighten the four (4) 1/4-20 x 7/8" socket head cap screws on the adjustable dovetail.

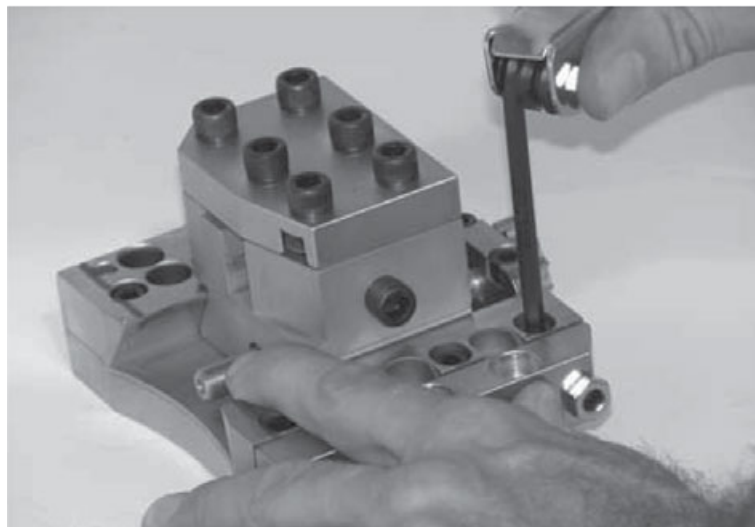

Figure 7-29. Tighten SHCS on dovetail.

15. Tighten the four (4) 1/4-20" socket cap screws on the starwheel plate.
16. Check the tension on the full range of the slide. It should be the same.

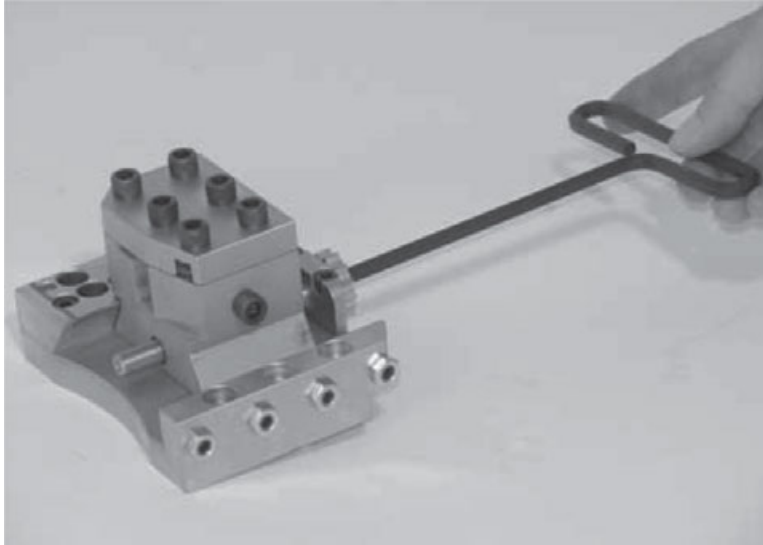

Figure 7-30. Check the tension on the slide by driving it to both ends of the feed screw.

- 17.** If you can still turn the starwheel with your bare hand, you need to slightly tighten the four (4) set screws once again so that the tension is the same throughout the travel of the tool slide.
- 18.** If a torque wrench is available, attach to the feed screw while turning the star wheel. Turning the starwheel should require 15-17 in/lb of torque.

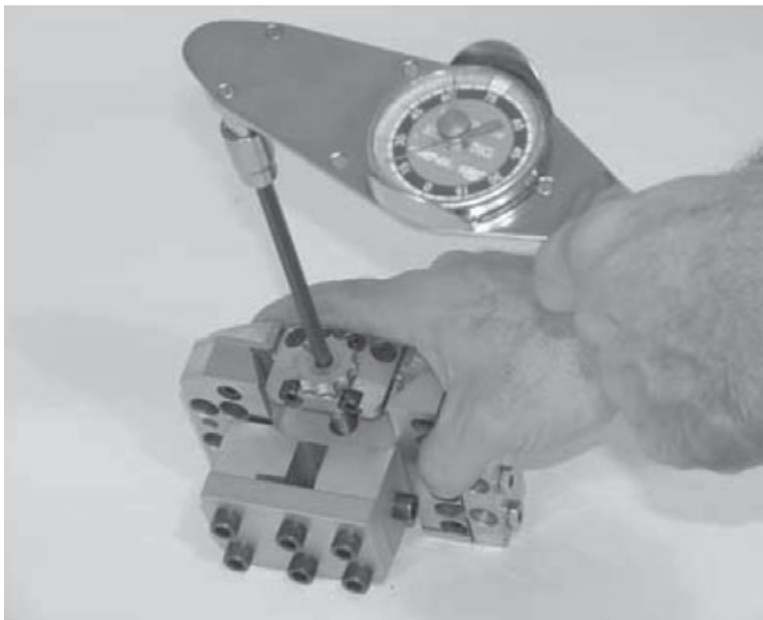

Figure 7-31. Adjust the feed screw with the torque wrench.

AIR MOTOR MAINTENANCE

See the exploded view drawings for air motors in the “Parts Lists and Drawing” section of this manual.

1. Clamp the flats of the handle in a vise with the tool in a vertical position.
2. Using a suitable wrench, loosen (left hand threads) the clamp nut and remove the angle head assembly. Unscrew and remove the clutch housing and gear case assemblies. Clamp the gear case in the vise and unscrew the clutch housing.
3. Slip the motor unit out the front of the handle. It may be necessary to bump the handle on the work bench to loosen the motor.

Disassembling Air Motor Subassemblies

Right Angle Head

1. Remove the bearing cap lock screw (1/16 hex) and unscrew (left hand threads) the bearing cap. Clamp the square drive in the vise and use a soft mallet to drive the angle head off. Press the spindle out of the driven gear and then press the spindle out of the ball bearing.
2. Unscrew and remove the bearing retainer and grease plug. Use a suitable driver to drive the pinion gear out of the housing.

Gear Case

1. Slip the entire gear train out the rear of the gear case. The 2nd reduction idler gears may be removed for inspection by driving the idler gear pins out the rear of the spider.

Motor

1. Use a soft faced mallet to drive the rotor out of the front rotor bearing. This will allow the removal of the front bearing plate, cylinder, and five (5) rotor blades from the rotor.
2. Clamp the rotor lightly in the vise and unscrew the rotor lock nut.
3. Rest the rear bearing plate on the vise jaws and use a soft faced mallet to drive the rotor out of the rear rotor bearing.

Handle

1. Unscrew the inlet bushing for inspection of the throttle components. Wash the air inlet screen in a solvent and blow it out in the reverse direction of normal airflow. Replace if damaged or clogged.

Reassembly

The tool is reassembled in the reverse order of disassembly.

1. Clean all parts thoroughly in a solvent and inspect for damage or wear.
2. Check all bearings for wear which can be detected by excessive end play and/or roughness that would indicate a brinelled condition.
3. The rotor blades should be replaced if they measure less than 3/8" (9.5 mm) at either end.
4. All gear teeth, bearings, and pins should receive a close inspection and be replaced if necessary. All gears and open bearings should receive a generous amount of No. 2 Moly grease during reassembly.

Motor

1. Install the rear rotor bearing into the rear bearing plate. Make sure the outer bearing race is firmly seated in the bearing plate.

IMPORTANT

During reassembly of the complete tool, it is important that the motor be free. After the tool is completely assembled, the right angle square drive spindle should turn freely using a small hand wrench. If the spindle does not turn freely, the motor should be checked for proper spacing. Do not run the tool until the spindle turns freely. Failure to do this could result in damage to motor components.

2. Clamp the rotor body lightly in the vise with the threaded end up and slip the rear bearing plate assembly onto the rotor shaft far enough for the bearing lock nut to start.
3. Tighten the lock nut until there is approximately .0015" clearance between the rotor and bearing plate. The outer bearing race should be firmly seated and the rotor bumped forward when checking this clearance.
4. Pack both rotor bearings with a good grade of No. 2 Moly grease after assembly of the motor unit.

Air Motor Vanes

Before installing new rotor vanes, you may need to grind them to ensure precise sizing according to the following chart.

Air Motor Part No.	Description	Rotor Blade Part No.	Min. Length	Max. Length
60-329-00	2-1/2 HP	899927	2.745"	2.748"
60-211-00	1-1/2 HP	869569	2.244"	2.247"

Right Angle Head

When installing needle bearings, press only on the bearing's stamped end. The pinion needle bearing should be slipped on the pinion gear and pressed into the housing to the following depth:



NOTE

When assembling the angle head to the complete tool, the clamp nut (left hand threads) must be torqued to 100/110 lb-ft (135/149 Nm).

- 3- 3/16" (81 mm).
- 1.** Tighten the pinion bearing retainer to 35 to 40 lb-ft (47.5 to 54.2 Nm) ensure proper gear make-up.
- 2.** Torque the driven gear bearing cap to 100/110 lb-ft (135/149 Nm).

Chapter 8

Parts Lists and Drawings

This chapter contains exploded view drawings with parts lists for LCSF models 204-1420, including sub-assemblies. To identify and order parts, locate the assembly for your LCSF model. Sub-assemblies are called out by part number on top-level assemblies.

Model 204 (4-inch LCSF), 60-000-04

ITEM NO.	PART NUMBER	QTY	DESCRIPTION
1	37-005-00	14	BEARING, GUIDE WHEEL
2	56-150-00	1	STORAGE CASE (NOT SHOWN)
3	60-028-00	2	LABEL, NO GAPS
4	60-099-00	1	LABEL (NOT SHOWN)
5	60-1105-04	1	4" ROTATING RING ASSEMBLY
6	60-1176-00	2	WIPER, 4-8 LCSF
7	60-1177-00	2	BRACKET, 4-8 LCSF WIPER
8	60-122-00	2	SCREW, CAPTIVATED 5/16-18
9	60-1242-00	2	SHAFT, SMALL FIXED BEARING
10	60-1243-00	12	SHAFT, SMALL ADJUSTABLE BEARING
11	60-1260-04	1	ASSEMBLY 4" STATIONARY FRAME
12	60-1274-00	2	TAG, LCSF
13	60-1275-00	1	LABEL, PIN LOCATION
14	60-129-00	2	PIN, FRAME LOCKING
15	60-130-00	14	PLUG, BEARING CAP
16	60-166-04	2	GUARD, CHIP LC4-12
17	60-351-08	1	INSERT FOAM (NOT SHOWN)
18	60-363-00	1	LABEL, MOVING PARTS
19	60-408-05	1	1/2" EXTENSION LEG SET (NOT SHOWN)
20	60-408-07	1	3/4" EXTENSION LEG SET (NOT SHOWN)
21	60-408-10	1	1.0" EXTENSION LEG SET (NOT SHOWN)
22	60-412-00	1	PINION HOUSING ASSEMBLY LCSF 4-20
23	60-447-02	4	CLAMP PAD ASSEMBLY 4-8
24	60-560-01	1	KIT, LCSF 4"-20" FASTENERS (NOT SHOWN)
25	60-600-00	1	TOOLS, 4"-20" LCSF HAND (NOT SHOWN)
26	60-MAN-07	1	MANUAL, 4"-20" LCSF (NOT SHOWN)
27	80-0080-00	1	NAME PLATE
28	90-025-01	4	WASHER, #8 FLAT
29	90-042-03	4	BHCS, 10-24 X 3/8
30	90-049-06	4	SCREW, #2-3/16 U-DRIVE
31	90-056-05	4	PIN, 1/4 X 1/2 DOWEL
32	90-065-01	14	NUT, 5/16-18 HEX
33	90-065-10	14	NUT, 5/16-18 HEAVY JAM
34	90-165-53	14	WASHER, 5/16 SECURING
35	90-900-01	1	LABEL, READ MANUAL .75 DIA.

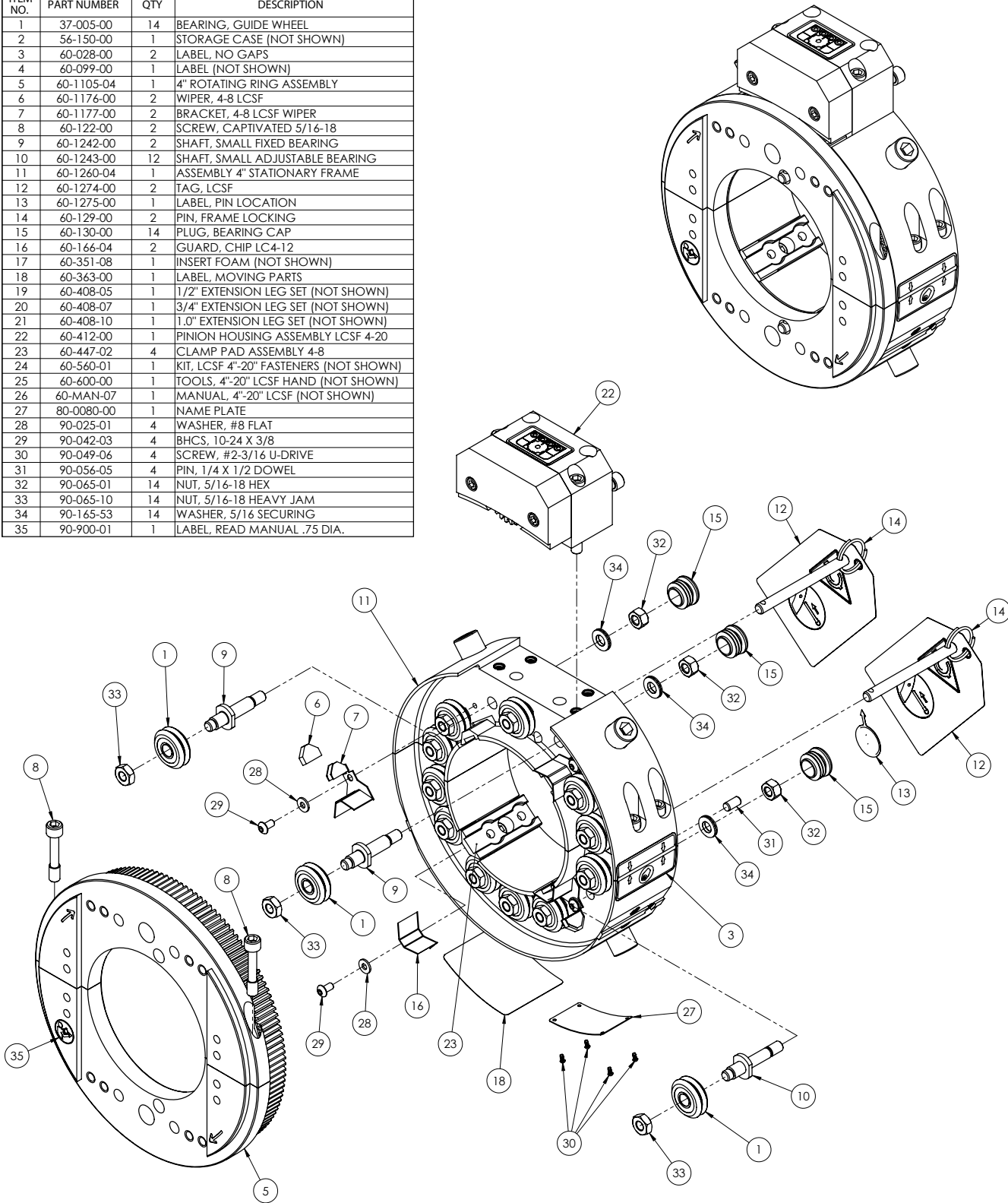

WIPERS (ITEM NO.: 6) REQUIRE WAY OIL (PART NO.: 60-1184-00) SOLD SEPARATELY.
OPERATING WEIGHT: 23 LB. [10.5 kg]

Model 206 (6-inch LCSF), 60-000-06

ITEM	PART NUMBER	QTY.	DESCRIPTION
1	37-005-00	14	BEARING, GUIDE WHEEL
2	56-150-00	1	CASE STORAGE (NOT SHOWN)
3	60-028-00	2	LABEL, NO GAPS
4	60-099-00	1	LABEL (NOT SHOWN)
5	60-1105-06	1	6" ROTATING RING ASSEMBLY
6	60-1178-00	2	WIPER, 10-20 LCSF
7	60-122-00	2	SCREW, CAPTIVATED 5/16-18
8	60-1242-00	2	SHAFT, SMALL FIXED BEARING
9	60-1243-00	12	SHAFT, SMALL ADJUSTABLE BEARING
10	60-1260-06	1	6" STATIONARY FRAME ASSEMBLY
11	60-1261-00	2	ASSEMBLY, 10-20 LCSF WIPER BRACKET
12	60-1274-00	2	TAG, LCSF
13	60-1275-00	1	LABEL, PIN LOCATION
14	60-1279-06	1	LABEL, WEIGHT-LCSF 206
15	60-129-00	2	PIN, FRAME LOCKING
16	60-130-00	14	PLUG, BEARING CAP
17	60-166-04	4	GUARD, CHIP LC4-12
18	60-351-08	1	INSERT FOAM (NOT SHOWN)
19	60-363-00	1	LABEL, MOVING PARTS
20	60-408-05	1	1/2" EXTENSION LEG SET (NOT SHOWN)
21	60-408-10	1	1.0" EXTENSION LEG SET (NOT SHOWN)
22	60-408-15	1	1-1/2" EXTENSION LEG SET (NOT SHOWN)
23	60-408-20	1	2.0" EXTENSION LEG SET (NOT SHOWN)
24	60-412-00	1	PINION HOUSING ASSEMBLY LCSF 4-20
25	60-447-02	4	CLAMP PAD ASSEMBLY 4-8
26	60-560-01	1	KIT, LCSF 4" - 20" FASTENERS (NOT SHOWN)
27	60-600-00	1	TOOLS, 4" - 20" LCSF HAND (NOT SHOWN)
28	60-MAN-07	1	MANUAL, SPLIT FRAME (NOT SHOWN)
29	80-0080-00	1	NAME PLATE
30	90-022-03	4	BHCS #8-32 x .375
31	90-025-01	4	WASHER, #8 FLAT
32	90-042-03	4	BHCS, 10-24 X 3/8
33	90-049-06	4	SCREW, #2-3/16 U-DRIVE
34	90-056-05	4	PIN, 1/4 X 1/2 DOWEL
35	90-065-01	14	NUT, 5/16-18 HEX
36	90-065-10	14	NUT, 5/16-18 HEAVY JAM
37	90-165-53	14	WASHER, 5/16 SECURING
38	90-900-00	1	LABEL, READ MANUAL 1.50 DIA.

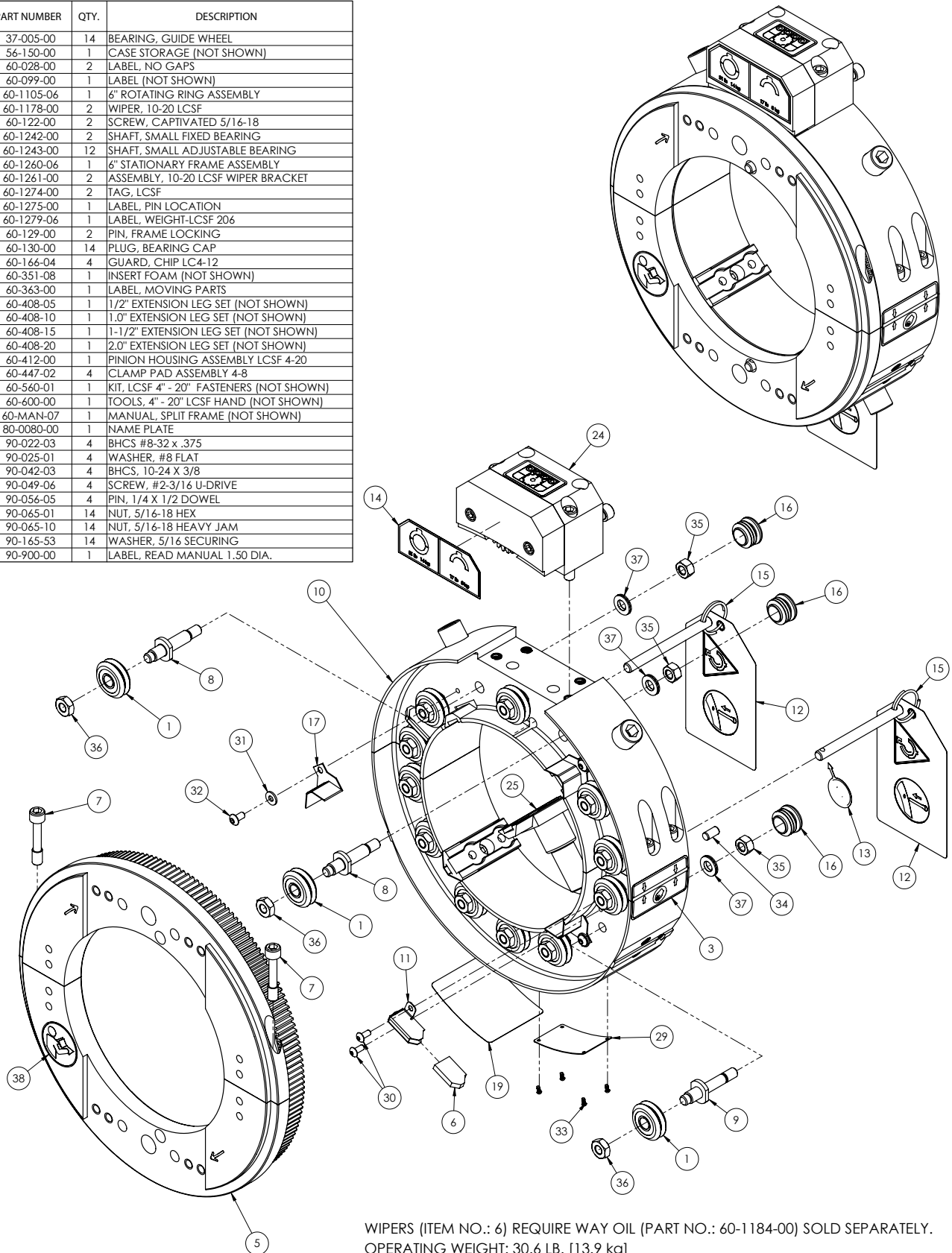

WIPERS (ITEM NO.: 6) REQUIRE WAY OIL (PART NO.: 60-1184-00) SOLD SEPARATELY.
 OPERATING WEIGHT: 30.6 LB. [13.9 kg]

Model 408 (8-inch LCSF), 60-000-08

ITEM	PART NUMBER	QTY.	DESCRIPTION
1	37-005-00	18	BEARING, GUIDE WHEEL
2	60-096-00	1	CASE, STORAGE (NOT SHOWN)
3	60-028-00	2	LABEL, NO GAPS
4	60-099-00	1	LABEL (NOT SHOWN)
5	60-1105-08	1	8" ROTATING RING ASSEMBLY
6	60-1178-00	2	WIPER, 10-20 LCSF
7	60-122-00	2	SCREW, CAPTIVATED 5/16-18
8	60-1242-00	2	SHAFT, SMALL FIXED BEARING
9	60-1243-00	16	SHAFT, SMALL ADJUSTABLE BEARING
10	60-1260-08	1	8" STATIONARY FRAME ASSEMBLY
11	60-1261-00	2	ASSEMBLY, 10-20 LCSF WIPER BRACKET
12	60-1274-00	2	TAG, LCSF
13	60-1275-00	1	LABEL, PIN LOCATION
14	60-129-00	2	PIN, FRAME LOCKING
15	60-130-00	18	PLUG, BEARING CAP
16	60-166-04	4	GUARD, CHIP LC4-12
17	60-094-00	1	INSERT, FOAM (NOT SHOWN)
18	60-363-00	1	LABEL, MOVING PARTS
19	60-408-10	1	1.0' EXTENSION LEG SET (NOT SHOWN)
20	60-408-20	1	2.0' EXTENSION LEG SET (NOT SHOWN)
21	60-412-00	1	PINION HOUSING ASSEMBLY LCSF 4-20
22	60-447-02	4	CLAMP PAD ASSEMBLY 4-8
23	60-560-01	1	KIT, LCSF 4" - 20" FASTENERS (NOT SHOWN)
24	60-600-00	1	TOOLS, 4" - 20" LCSF, HAND (NOT SHOWN)
25	60-MAN-07	1	MANUAL, SPLIT FRAME (NOT SHOWN)
26	80-0080-00	1	NAME PLATE
27	90-022-03	4	BHCS #8-32 x .375
28	90-025-01	4	WASHER, #8 FLAT
29	90-042-03	4	BHCS, 10-24 X 3/8
30	90-049-04	4	SCREW, #2-3/16 U-DRIVE
31	90-056-05	4	PIN, 1/4 X 1/2 DOWEL
32	90-065-01	18	NUT, 5/16-18 HEX
33	90-065-10	18	NUT, 5/16-18 HEAVY JAM
34	90-165-53	18	WASHER, 5/16 SECURING
35	90-900-00	1	LABEL, READ MANUAL 1.50 DIA.

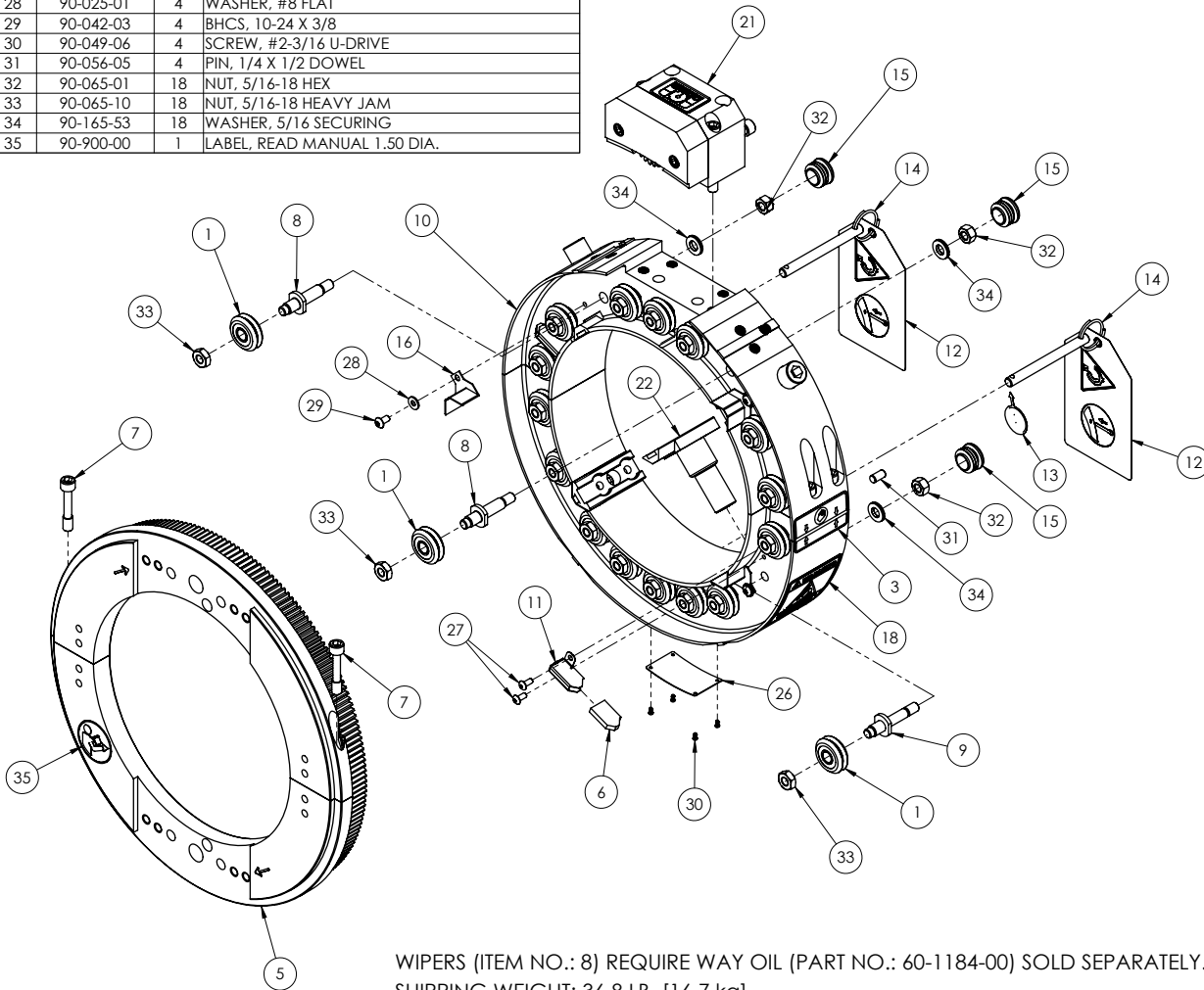
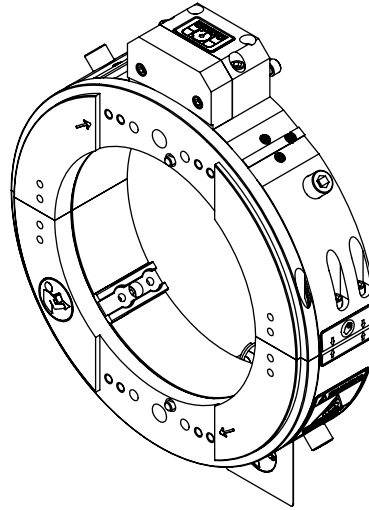

WIPERS (ITEM NO.: 8) REQUIRE WAY OIL (PART NO.: 60-1184-00) SOLD SEPARATELY.
SHIPPING WEIGHT: 36.8 LB. [16.7 kg]

Model 610 (10-inch LCSF), 60-000-10

ITEM	PART NUMBER	QTY.	DESCRIPTION
1	37-005-00	22	BEARING, GUIDE WHEEL
2	60-028-00	2	LABEL, NO GAPS
3	60-094-00	1	INSERT, FOAM (NOT SHOWN)
4	60-096-00	1	CASE (NOT SHOWN)
5	60-099-00	1	LABEL (NOT SHOWN)
6	60-1105-10	1	10" ROTATING RING ASSEMBLY
7	60-1178-00	2	WIPER, 10-20 LCSF
8	60-122-00	2	SCREW, CAPTIVATED 5/16-18
9	60-1242-00	2	SHAFT, SMALL FIXED BEARING
10	60-1243-00	20	SHAFT, SMALL ADJUSTABLE BEARING
11	60-1260-10	1	10" STATIONARY FRAME ASSEMBLY
12	60-1261-00	2	ASSEMBLY, 10-20 LCSF WIPER BRACKET
13	60-1274-00	2	TAG, LCSF
14	60-1275-00	1	LABEL, PIN LOCATION
15	60-129-00	2	PIN, FRAME LOCKING
16	60-130-00	22	PLUG, BEARING CAP
17	60-166-04	4	GUARD, CHIP LC4-12
18	60-363-00	1	LABEL, MOVING PARTS
19	60-408-10	1	1.0" EXTENSION LEG SET (NOT SHOWN)
20	60-408-20	1	2.0" EXTENSION LEG SET (NOT SHOWN)
21	60-412-00	1	PINION HOUSING ASSEMBLY LCSF 4-20
22	60-447-03	4	CLAMP PAD ASSEMBLY 10-20
23	60-560-01	1	KIT, LCSF 4" - 20" FASTENERS (NOT SHOWN)
24	60-600-00	1	TOOLS, 4" - 20" LCSF HAND (NOT SHOWN)
25	60-MAN-07	1	MANUAL, SPLIT FRAME (NOT SHOWN)
26	80-0080-00	1	NAME PLATE
27	90-022-03	4	BHCS #8-32 x .375
28	90-025-01	4	WASHER, #8 FLAT
29	90-042-03	4	BHCS, 10-24 X 3/8
30	90-049-06	4	SCREW, #2-3/16 U-DRIVE
31	90-056-05	4	PIN, 1/4 X 1/2 DOWEL
32	90-065-01	22	NUT, 5/16-18 HEX
33	90-065-10	22	NUT, 5/16-18 HEAVY JAM
34	90-099-92	2	EYE BOLT
35	90-165-53	22	WASHER, 5/16 SECURING
36	90-900-00	1	LABEL, READ MANUAL 1.50 DIA.

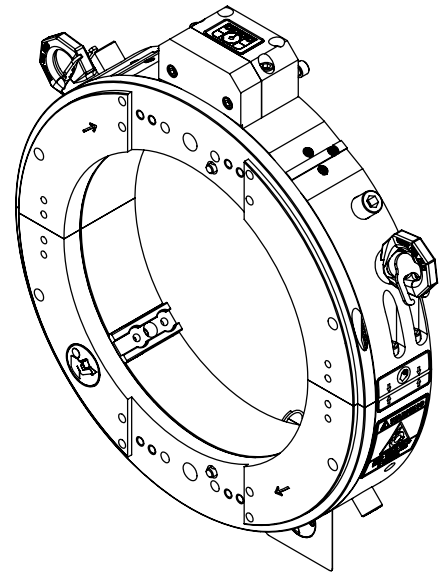

WIPERS (ITEM NO.: 9) REQUIRE WAY OIL
(PART NO.: 60-1184-00) SOLD SEPARATELY.

OPERATING WEIGHT: 48.6 LB. [22.1 kg]

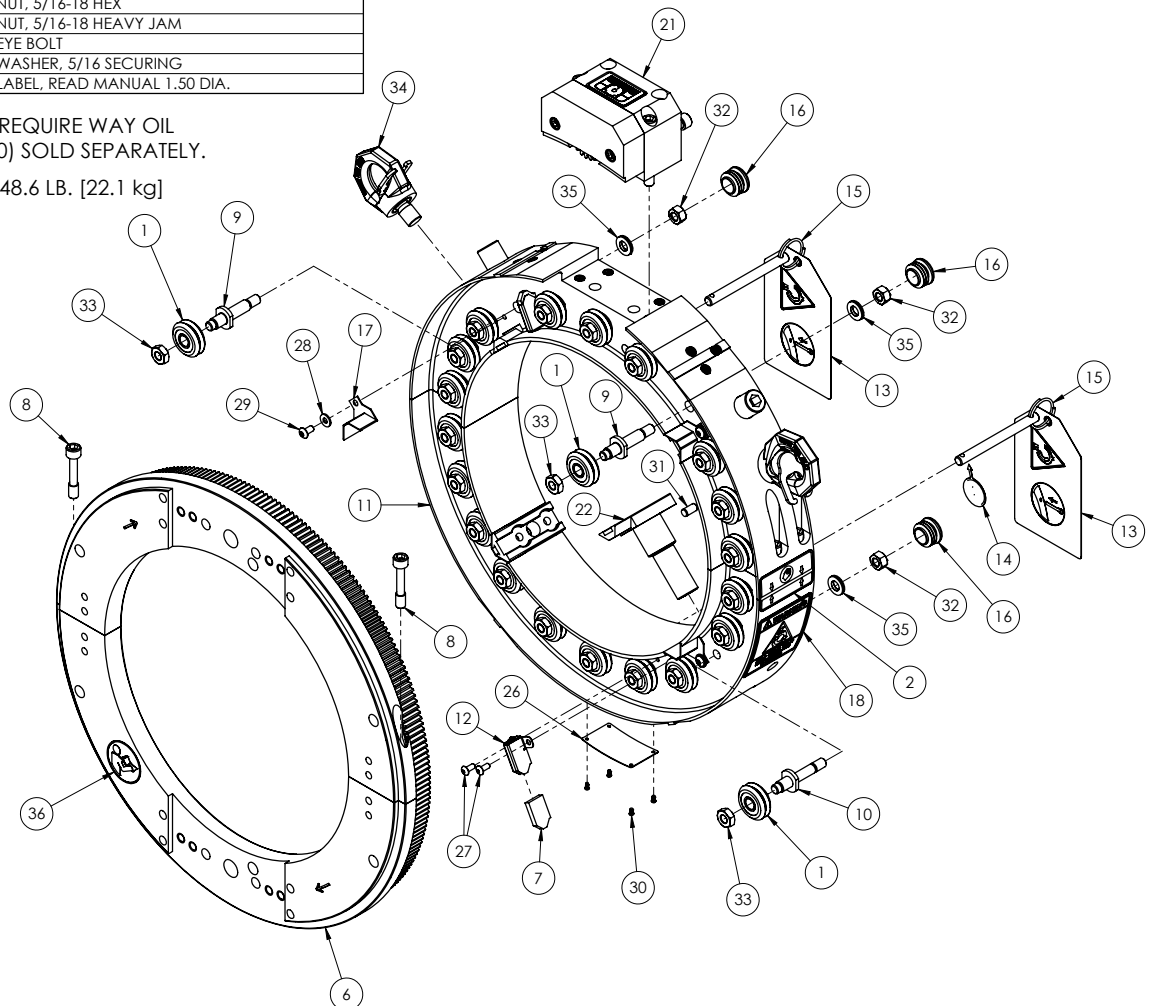

Model 612 (12-inch LCSF), 60-000-12

ITEM	PART NUMBER	QTY.	DESCRIPTION
1	37-005-00	22	BEARING, GUIDE WHEEL
2	60-028-00	2	LABEL, NO GAPS
3	60-094-00	1	INSERT FOAM (NOT SHOWN)
4	60-096-00	1	CASE (NOT SHOWN)
5	60-099-00	1	LABEL (NOT SHOWN)
6	60-1105-12	1	12" ROTATING RING ASSEMBLY
7	60-1178-00	2	WIPER, 10-20 LCSF
8	60-122-00	2	SCREW, CAPTIVATED 5/16-18
9	60-1242-00	2	SHAFT, SMALL FIXED BEARING
10	60-1243-00	20	SHAFT, SMALL ADJUSTABLE BEARING
11	60-1260-12	1	12" STATIONARY FRAME ASSEMBLY
12	60-1261-00	2	ASSEMBLY, 10-20 LCSF WIPER BRACKET
13	60-1274-00	2	TAG, LCSF
14	60-1275-00	1	LABEL, PIN LOCATION
15	60-1279-12	1	LABEL, WEIGHT-LCSF 612
16	60-129-00	2	PIN, FRAME LOCKING
17	60-130-00	22	PLUG, BEARING CAP
18	60-166-04	4	GUARD, CHIP LC4-12
19	60-363-00	1	LABEL, MOVING PARTS
20	60-408-10	1	1.0" EXTENSION LEG SET (NOT SHOWN)
21	60-408-20	1	2.0" EXTENSION LEG SET (NOT SHOWN)
22	60-408-30	1	3.0" EXTENSION LEG SET (NOT SHOWN)
23	60-412-00	1	PINION HOUSING ASSEMBLY LCSF 4-20
24	60-447-03	4	CLAMP PAD ASSEMBLY 10-20
25	60-560-01	1	KIT, LCSF 4" - 20" FASTENERS (NOT SHOWN)
26	60-600-00	1	TOOLS, 4" - 20" LCSF HAND (NOT SHOWN)
27	60-MAN-07	1	MANUAL, SPLIT FRAME (NOT SHOWN)
28	80-0080-00	1	NAME PLATE
29	90-022-03	4	BHCS #8-32 x .375
30	90-025-01	4	WASHER, #8 FLAT
31	90-042-03	4	BHCS, 10-24 X 3/8
32	90-049-06	4	SCREW, #2-3/16 U-DRIVE
33	90-056-05	4	PIN, 1/4 X 1/2 DOWEL
34	90-065-01	22	NUT, 5/16-18 HEX
35	90-065-10	22	NUT, 5/16-18 HEAVY JAM
36	90-099-92	2	EYE BOLT
37	90-165-53	22	WASHER, 5/16 SECURING
38	90-900-00	1	LABEL, READ MANUAL 1.50 DIA.

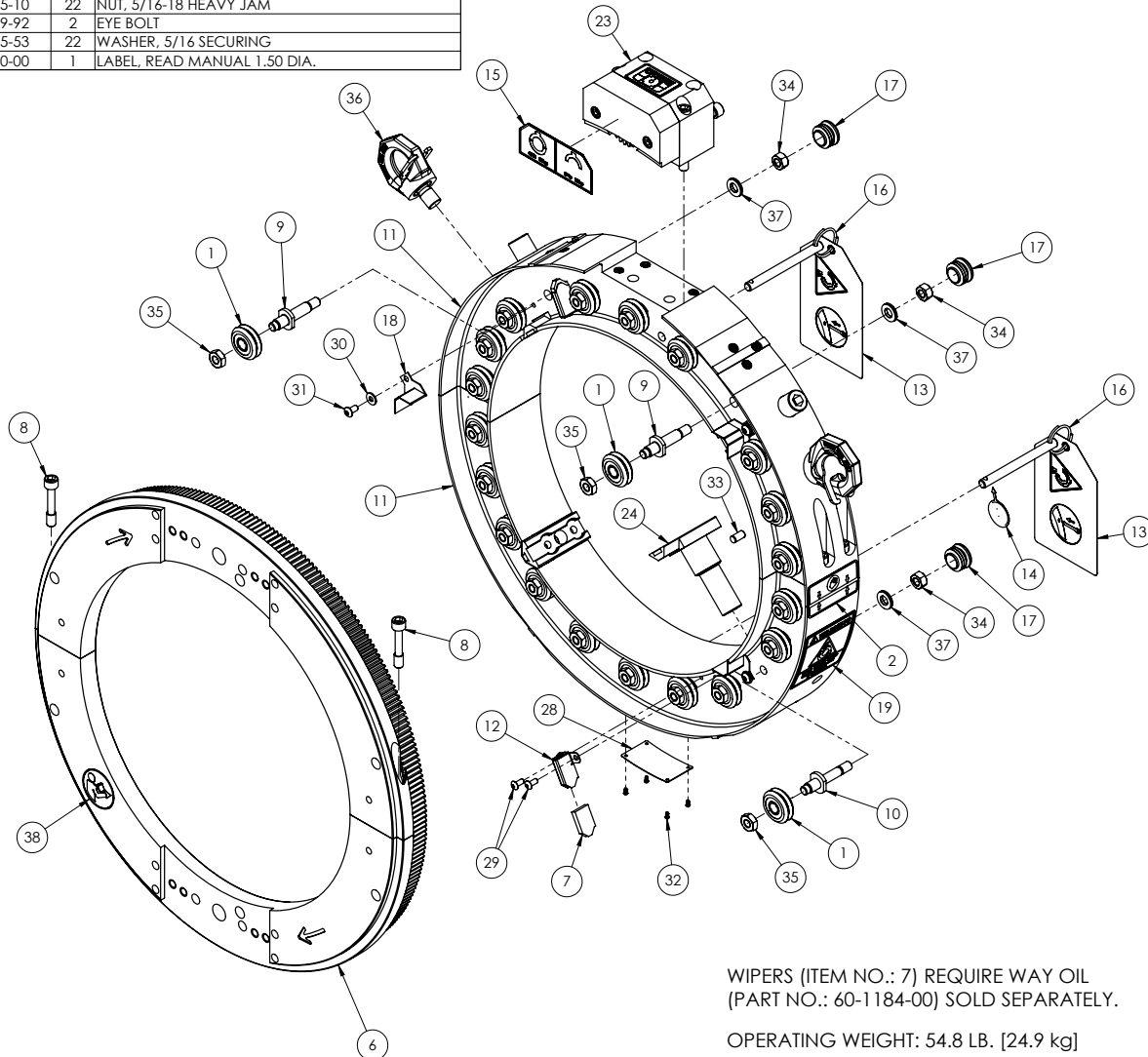
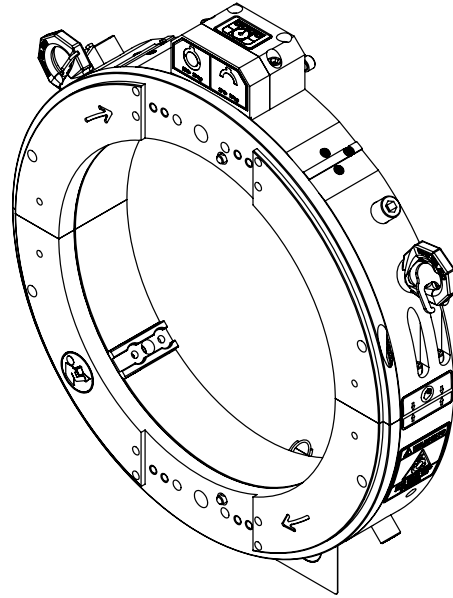

WIPERS (ITEM NO.: 7) REQUIRE WAY OIL
(PART NO.: 60-1184-00) SOLD SEPARATELY.

OPERATING WEIGHT: 54.8 LB. [24.9 kg]

Model 814 (14-inch LCSF), 60-000-14

ITEM	PART NUMBER	QTY.	DESCRIPTION
1	37-005-00	22	BEARING, GUIDE WHEEL
2	60-028-00	2	LABEL, NO GAPS
3	60-094-00	1	INSERT FOAM (NOT SHOWN)
4	60-096-00	1	CASE (NOT SHOWN)
5	60-099-00	1	LABEL (NOT SHOWN)
6	60-1105-14	1	14" ROTATING RING ASSEMBLY
7	60-1178-00	2	WIPER, 10-20 LCSF
8	60-122-00	2	SCREW, CAPTIVATED 5/16-18
9	60-1242-00	2	SHAFT, SMALL FIXED BEARING
10	60-1243-00	20	SHAFT, SMALL ADJUSTABLE BEARING
11	60-1260-14	1	14" STATIONARY FRAME ASSEMBLY
12	60-1261-00	2	ASSEMBLY, 10-20 LCSF WIPER BRACKET
13	60-1274-00	2	TAG, LCSF
14	60-1275-00	1	LABEL, PIN LOCATION
15	60-1279-14	1	LABEL, WEIGHT-LCSF 814
16	60-129-00	2	PIN, FRAME LOCKING
17	60-130-00	22	PLUG, BEARING CAP
18	60-166-04	4	GUARD, CHIP LC4-12
19	60-363-00	1	LABEL, MOVING PARTS
20	60-408-05	1	1/2" EXTENSION LEG SET (NOT SHOWN)
21	60-408-15	1	1-1/2" EXTENSION LEG SET (NOT SHOWN)
22	60-408-25	1	2-1/2" EXTENSION LEG SET (NOT SHOWN)
23	60-412-00	1	PINION HOUSING ASSEMBLY LCSF 4-20
24	60-447-03	4	CLAMP PAD ASSEMBLY 10-20
25	60-560-01	1	KIT, LCSF 4" - 20" FASTENERS (NOT SHOWN)
26	60-600-00	1	TOOLS, 4" - 20" LCSF HAND (NOT SHOWN)
27	60-MAN-07	1	MANUAL, SPLIT FRAME (NOT SHOWN)
28	80-0080-00	1	NAME PLATE
29	90-022-03	4	BHCS #8-32 x .375
30	90-025-01	4	WASHER, #8 FLAT
31	90-042-03	4	BHCS, 10-24 X 3/8
32	90-049-06	4	SCREW, #2-3/16 U-DRIVE
33	90-056-05	4	PIN, 1/4 X 1/2 DOWEL
34	90-065-01	22	NUT, 5/16-18 HEX
35	90-065-10	22	NUT, 5/16-18 HEAVY JAM
36	90-099-92	2	EYE BOLT
37	90-165-53	22	WASHER, 5/16 SECURING
38	90-900-00	1	LABEL, READ MANUAL 1.50 DIA.

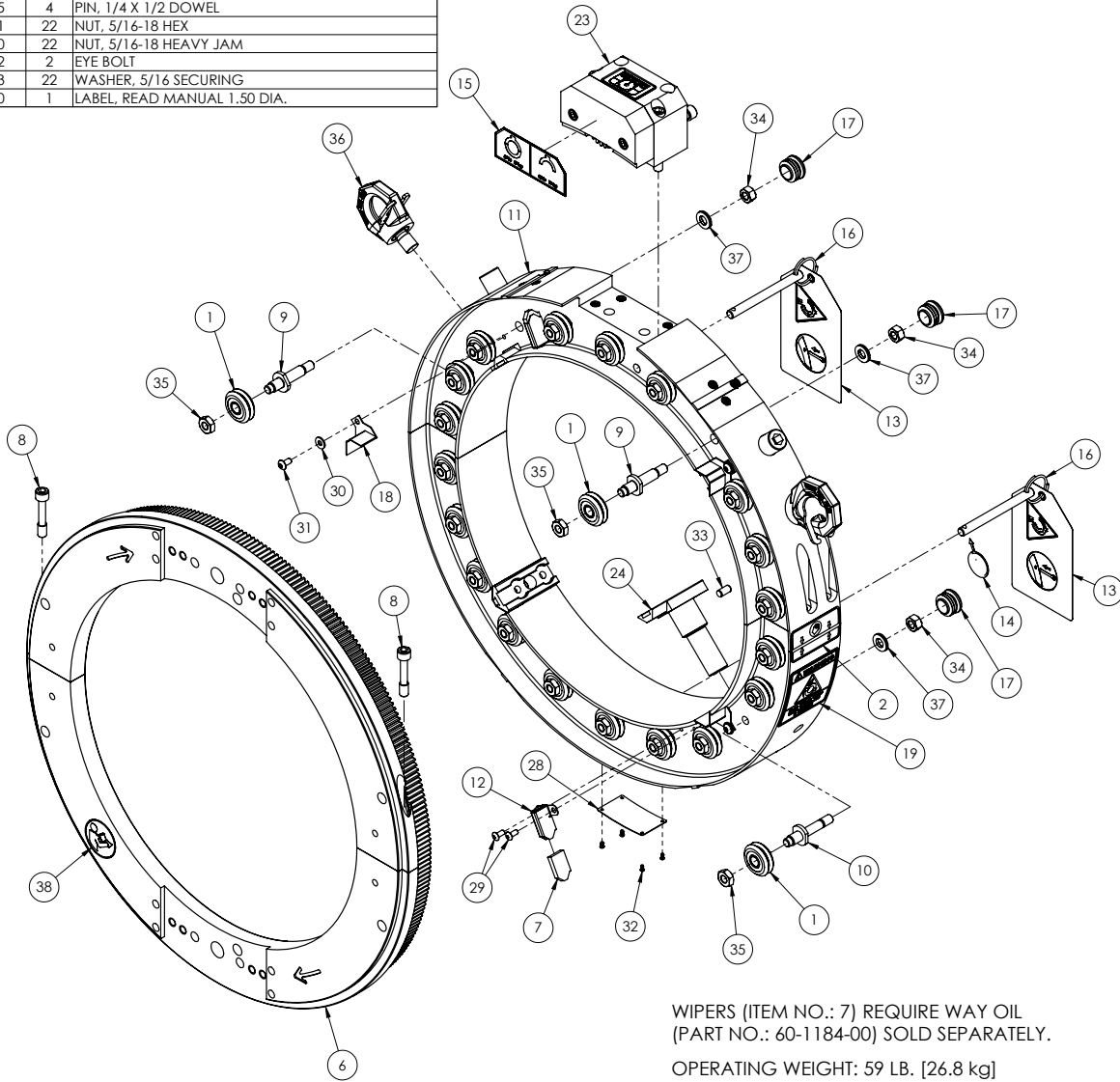
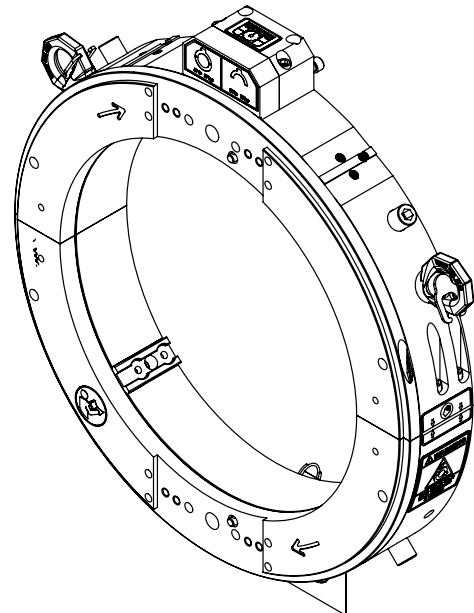

WIPERS (ITEM NO.: 7) REQUIRE WAY OIL
(PART NO.: 60-1184-00) SOLD SEPARATELY.
OPERATING WEIGHT: 59 LB. [26.8 kg]

Model 1016 (16-inch LCSF), 60-000-16

ITEM	PART NUMBER	QTY.	DESCRIPTION
1	37-005-00	30	BEARING, GUIDE WHEEL
2	60-028-00	2	LABEL, NO GAPS
3	60-095-00	1	INSERT, FOAM (NOT SHOWN)
4	60-096-00	1	CASE (NOT SHOWN)
5	60-099-00	1	LABEL (NOT SHOWN)
6	60-1105-16	1	16" ROTATING RING ASSEMBLY
7	60-1178-00	2	WIPER, 10-20 LCSF
8	60-1242-00	2	SHAFT, SMALL FIXED BEARING
9	60-1243-00	28	SHAFT, SMALL ADJUSTABLE BEARING
10	60-1260-16	1	16" STATIONARY FRAME ASSEMBLY
11	60-1261-00	2	ASSEMBLY, 10-20 LCSF WIPER BRACKET
12	60-1274-00	2	TAG, LCSF
13	60-1275-00	1	LABEL, PIN LOCATION
14	60-129-00	2	PIN, FRAME LOCKING
15	60-130-00	30	PLUG, BEARING CAP
16	60-207-00	2	SCREW, CAPTIVE FRAME
17	60-363-00	1	LABEL, MOVING PARTS
18	60-408-10	1	1.0" EXTENSION LEG SET (NOT SHOWN)
19	60-408-15	1	1-1/2" EXTENSION LEG SET (NOT SHOWN)
20	60-408-25	1	2-1/2" EXTENSION LEG SET (NOT SHOWN)
21	60-412-00	1	PINION HOUSING ASSEMBLY LCSF 4-20
22	60-447-03	4	CLAMP PAD ASSEMBLY 10-20
23	60-560-01	1	KIT, LCSF 4" - 20" FASTENERS (NOT SHOWN)
24	60-600-00	1	TOOLS, 4" - 20" LCSF HAND (NOT SHOWN)
25	60-MAN-07	1	MANUAL, SPLIT FRAME (NOT SHOWN)
26	80-0080-00	1	NAME PLATE
27	90-022-03	4	BHCS #8-32 x .375
28	90-049-06	4	SCREW, #2-3/16 U-DRIVE
29	90-056-05	4	PIN, 1/4 X 1/2 DOWEL
30	90-065-01	30	NUT, 5/16-18 HEX
31	90-065-10	30	NUT, 5/16-18 HEAVY JAM
32	90-099-92	2	EYE BOLT
33	90-165-53	30	WASHER, 5/16 SECURING
34	90-900-00	1	LABEL, READ MANUAL 1.50 DIA.

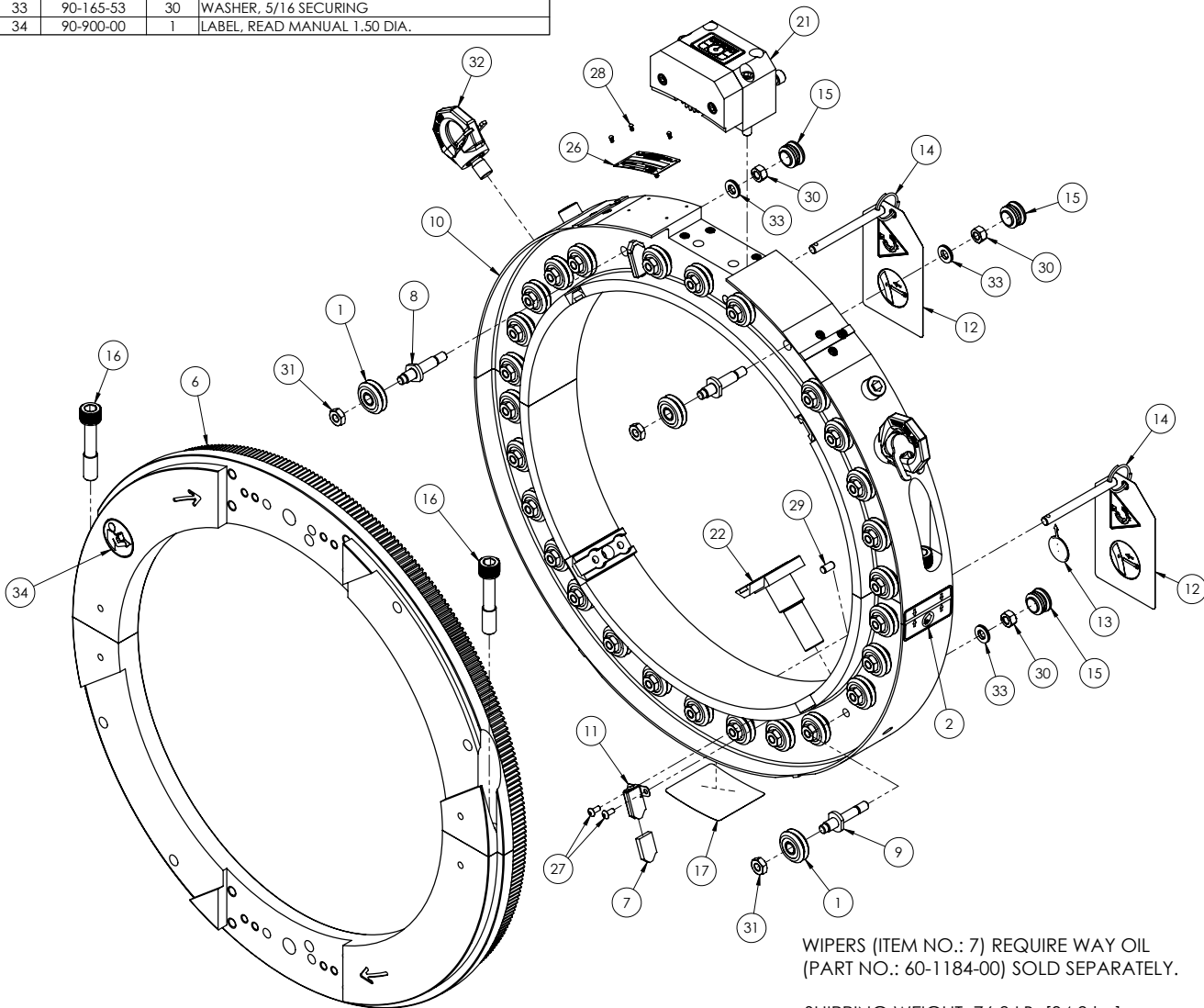
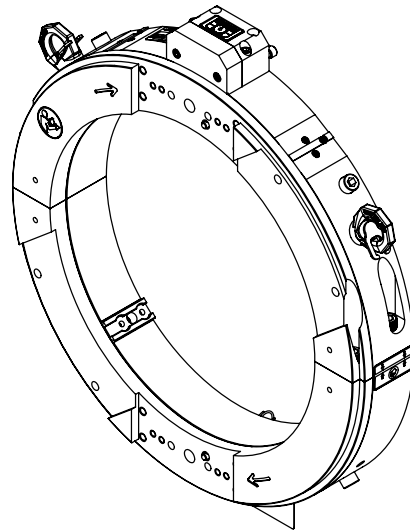

WIPERS (ITEM NO.: 7) REQUIRE WAY OIL
(PART NO.: 60-1184-00) SOLD SEPARATELY.

SHIPPING WEIGHT: 76.8 LB. [34.9 kg]

Model 1420 (20-inch LCSF), 60-000-20

ITEM	PART NUMBER	QTY.	DESCRIPTION
1	37-005-00	30	BEARING, GUIDE WHEEL
2	60-028-00	2	LABEL, NO GAPS
3	60-095-00	1	INSERT, FOAM (NOT SHOWN)
4	60-096-00	1	CASE (NOT SHOWN)
5	60-099-00	1	LABEL (NOT SHOWN)
6	60-1105-20	1	20" ROTATING RING ASSEMBLY
7	60-1178-00	2	WIPER, 10-20 LCSF
8	60-1242-00	2	SHAFT, SMALL FIXED BEARING
9	60-1243-00	28	SHAFT, SMALL ADJUSTABLE BEARING
10	60-1260-20	1	20" STATIONARY FRAME ASSEMBLY
11	60-1261-00	2	ASSEMBLY, 10-20 LCSF WIPER BRACKET
12	60-1274-00	2	TAG, LCSF
13	60-1275-00	1	LABEL, PIN LOCATION
14	60-1279-20	1	LABEL, WEIGHT-LCSF 1420
15	60-129-00	2	PIN, FRAME LOCKING
16	60-130-00	30	PLUG, BEARING CAP
17	60-207-00	2	SCREW, CAPTIVE FRAME
18	60-363-00	1	LABEL, MOVING PARTS
19	60-408-10	1	1.0" EXTENSION LEG SET (NOT SHOWN)
20	60-408-20	1	2.0" EXTENSION LEG SET (NOT SHOWN)
21	60-408-30	1	3.0" EXTENSION LEG SET (NOT SHOWN)
22	60-412-00	1	PINION HOUSING ASSEMBLY LCSF 4-20
23	60-447-03	4	CLAMP PAD ASSEMBLY 10-20
24	60-560-01	1	KIT, LCSF 4" - 20" FASTENERS (NOT SHOWN)
25	60-600-00	1	TOOLS, 4" - 20" LCSF HAND (NOT SHOWN)
26	60-MAN-07	1	MANUAL, SPLIT FRAME (NOT SHOWN)
27	80-0080-00	1	NAME PLATE
28	90-022-03	4	BHCS #8-32 x .375
29	90-049-06	4	SCREW, #2-3/16 U-DRIVE
30	90-056-05	4	PIN, 1/4 X 1/2 DOWEL
31	90-065-01	30	NUT, 5/16-18 HEX
32	90-065-10	30	NUT, 5/16-18 HEAVY JAM
33	90-099-92	2	EYE BOLT
34	90-165-53	30	WASHER, 5/16 SECURING
35	90-900-00	1	LABEL, READ MANUAL 1.50 DIA.

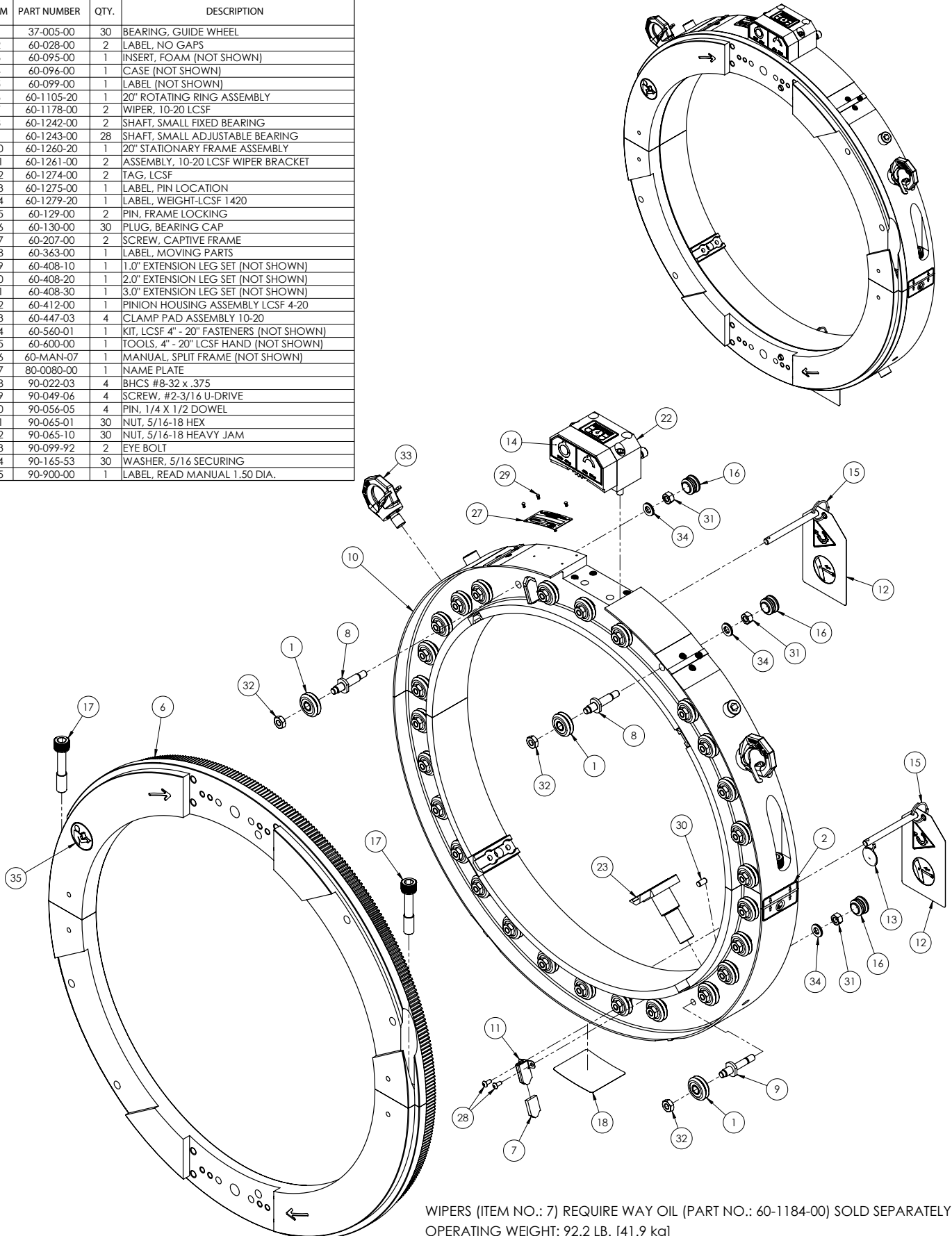

WIPERS (ITEM NO.: 7) REQUIRE WAY OIL (PART NO.: 60-1184-00) SOLD SEPARATELY.
 OPERATING WEIGHT: 92.2 LB. [41.9 kg]

Stationary Ring Assembly (Models 204 through 814)

ITEM	PART NUMBER	QTY.	DESCRIPTION
1	43-038-00	2	BUSHING, OUTER-RING
2	60-122-00	4	SCREW, CAPTIVATED 5/16-18
3	SEE TABLE	1	STATIONARY RING
4	SEE TABLE	1	STATIONARY RING
5	90-056-05	2	PIN, 1/4 X 1/2 DOWEL
6	90-069-12	14	INSERT, 5/16-18 X 1.5 D (.47 LG.) HELICAL
7	90-219-75	4	INSERT, 3/4-10 X 1 D (.75 LG.) HELICAL

TABLE		
LCSF MODEL	STATIONARY RING, UPPER	STATIONARY RING, LOWER
60-000-04	60-100-04	60-101-04
60-000-06	60-100-06	60-101-06
60-000-08	60-100-08	60-101-08
60-000-10	60-100-10	60-101-10
60-000-12	60-100-12	60-101-12
60-000-14	60-100-14	60-101-14

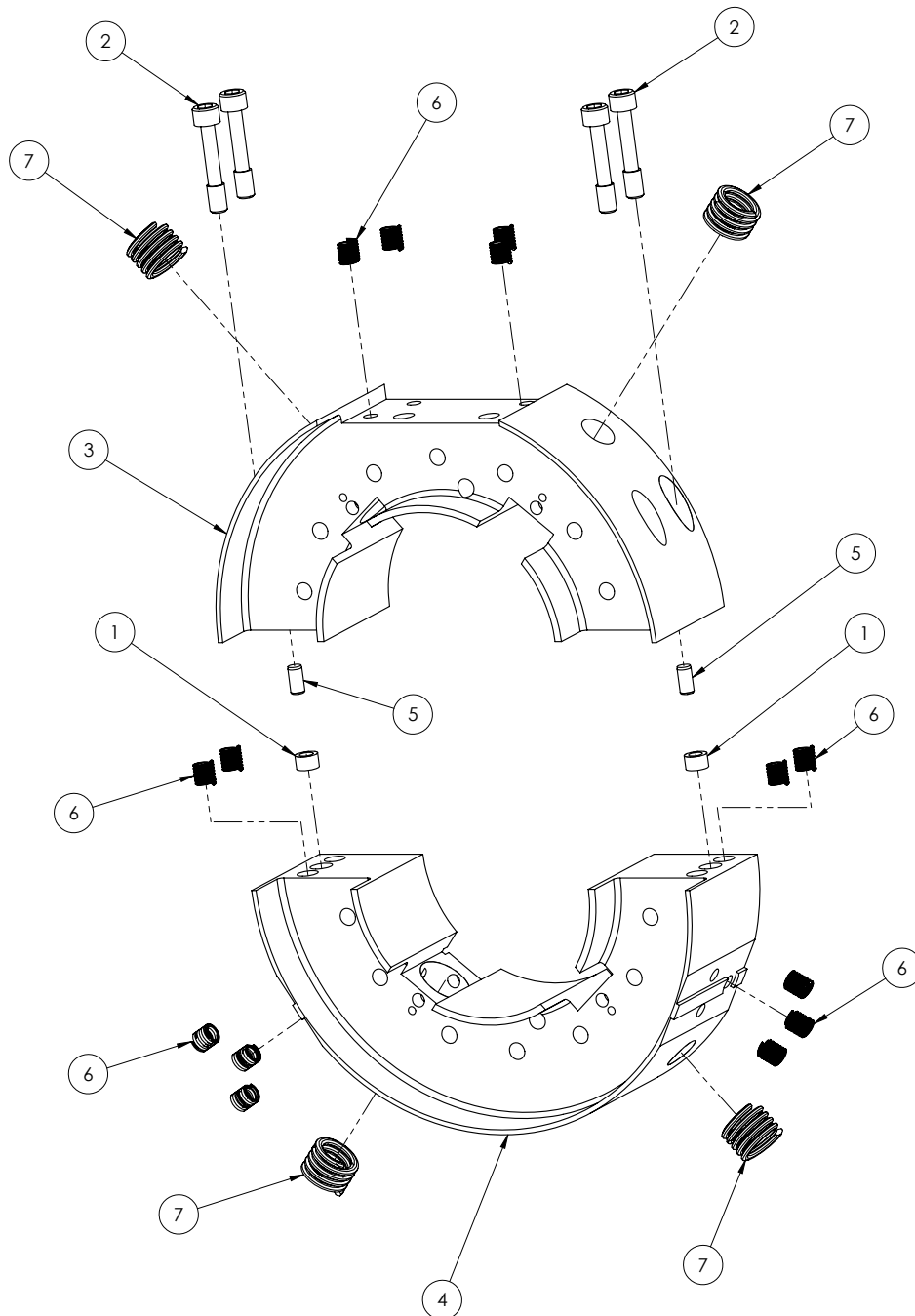

Stationary Ring Assembly (Models 1016 and 1420)

ITEM	PART NUMBER	QTY.	DESCRIPTION
1	60-207-00	2	SCREW, CAPTIVE FRAME
2	60-208-00	2	BUSHING, JIG
3	SEE TABLE	1	STATIONARY RING
4	SEE TABLE	1	STATIONARY RING
5	90-069-12	10	INSERT, 5/16-18 X 1.5 D (.47 LG) HELICAL
6	90-076-07	2	PIN, 3/8 X 3/4 DOWEL
7	90-099-13	2	INSERT, 1/2-13 X 1.5D (.75 LG.) HELICAL
8	90-219-75	4	INSERT, 3/4-10 X 1D (.75 LG.) HELICAL

TABLE		
LCSF MODEL	STATIONARY RING, UPPER	STATIONARY RING, LOWER
60-000-16	60-365-16	60-366-16
60-000-20	60-365-20	60-366-20

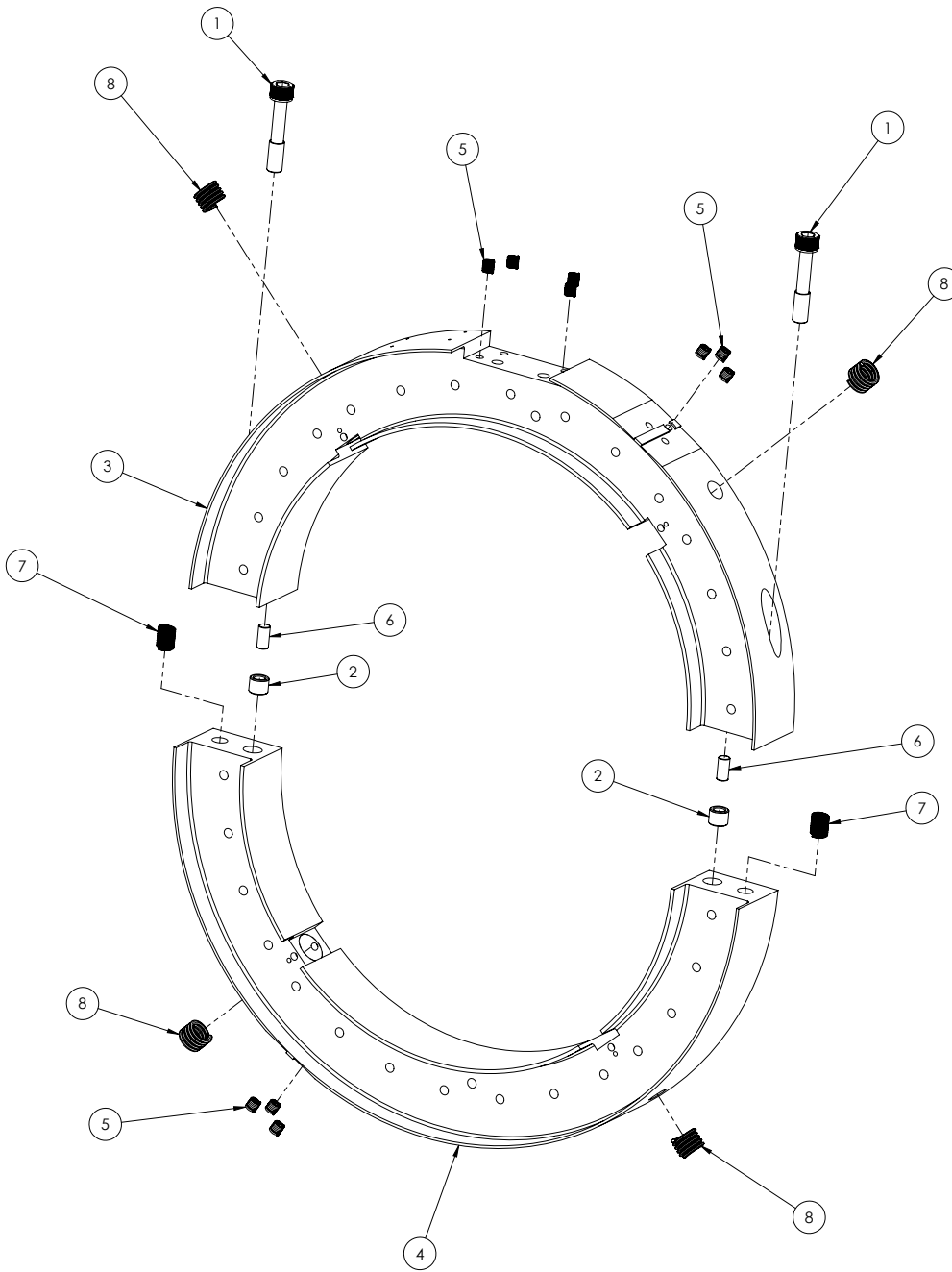

Wiper Kit Assemblies, 60-552-01 and 60-552-02

ITEM	PART NUMBER	QTY.	DESCRIPTION
1	60-1176-00	2	WIPER, 4-8 LCSF
2	60-1177-00	2	BRACKET, 4-8 LCSF WIPER

Wiper Kit, 60-552-01.

Used with these LCSF models:
60-000-04, 60-000-06, 60-000-08.

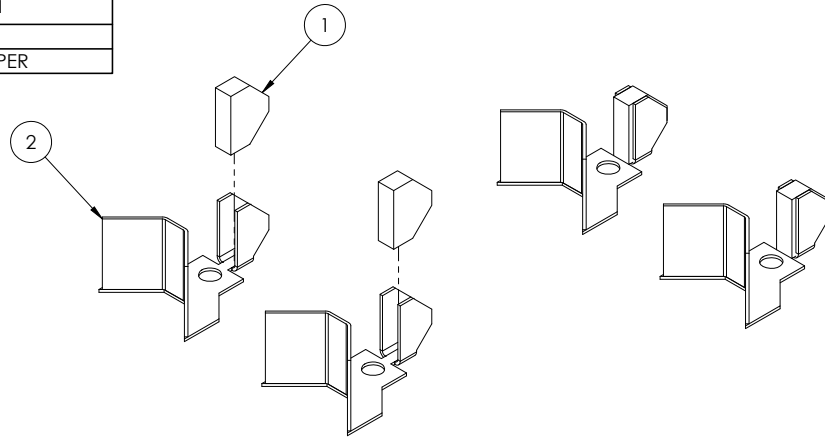

ITEM	PART NUMBER	QTY.	DESCRIPTION
1	60-1178-00	2	WIPER, 10-20 LCSF
2	60-1179-00	2	SPACER, 10-20 LCSF WIPER
3	60-1180-00	2	BRACKET, LCSF 10-20 WIPER

Wiper Kit, 60-552-02.

Used with these LCSF models:
60-000-10, 60-000-12, 60-000-14,
60-000-16, 60-000-20.

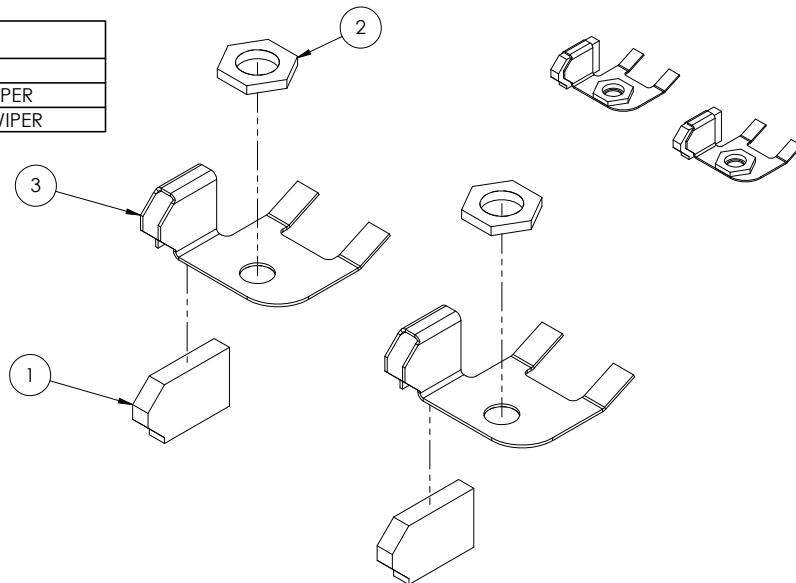

Pinion Housing, 60-412-00

This is the standard pinion housing for LCSF models 204-1420.

ITEM	PART NUMBER	QTY	DESCRIPTION
1	60-1235-00	1	BEARING, DEEP GROOVE BALL
2	60-1237-00	1	GEAR, 23T PINION
3	60-1238-00	1	HOUSING, 23T PINION
4	60-1239-00	1	COVER, 23T PINION
5	60-1240-00	1	BEARING, DBL ROW ANGULAR CONTACT
6	60-1241-00	1	RING, RETAINING
7	60-181-00	1	LABEL, STARWHEEL
8	90-050-11	2	SHCS, 1/4-20 x 1-1/8
9	90-060-07	2	SHCS, 5/16-18 X 3/4
10	90-060-22	4	SHCS, 5/16-18 x 2-1/4
11	90-076-05	2	PIN, 3/8 X 1/2 DOWEL

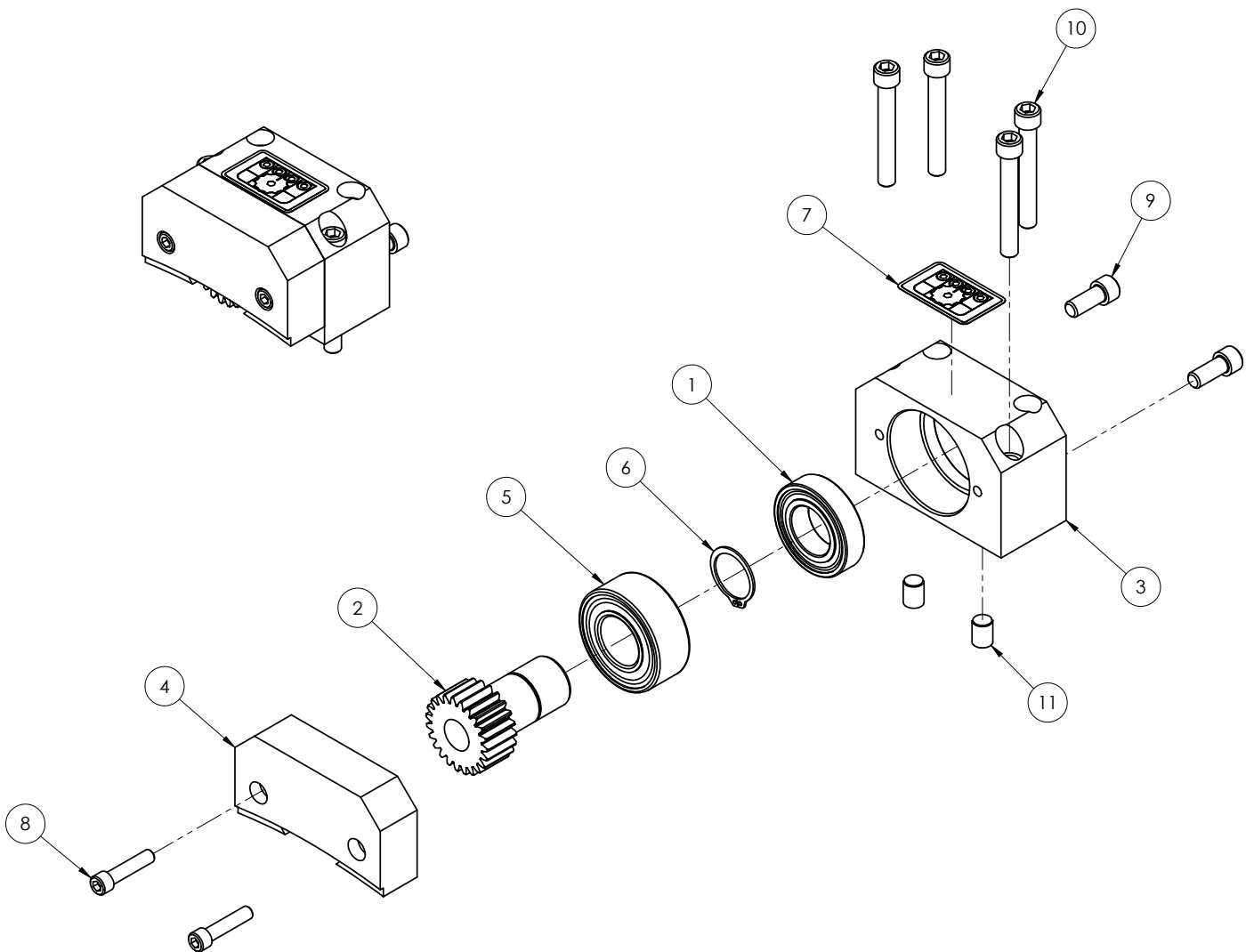

Front Drive Pinion Housing, 60-425-03

The front drive pinion housing is optional on LCSF models 204-1420.

ITEM	PART NUMBER	QTY.	DESCRIPTION
1	60-125-00	3	BEARING, PINION-REAR
2	60-341-00	1	HOUSING, PINION-FRONT 4"-20" LCSF
3	60-342-00	1	HOUSING, PINION-REAR 4"-20" LCSF
4	60-343-00	1	GEAR, PINION-FRONT DRIVE 4"-20" LCSF
5	60-344-00	1	GEAR, IDLER-FRONT DRIVE LCSF 4"-20"
6	60-345-00	1	BEARING, PINION GEAR
7	90-060-07	2	SHCS, 5/16-18 X 3/4
8	90-060-10	4	SHCS, 5/16-18 X 1
9	90-060-20	4	SHCS, 5/16-18 X 2
10	90-069-12	2	INSERT, 5/16-18 X 1.5 D (.47 LG) HELICAL
11	90-076-07	2	PIN, 3/8 X 3/4 DOWEL
12	90-076-10	2	PIN, 3/8 X 1.0 DOWEL

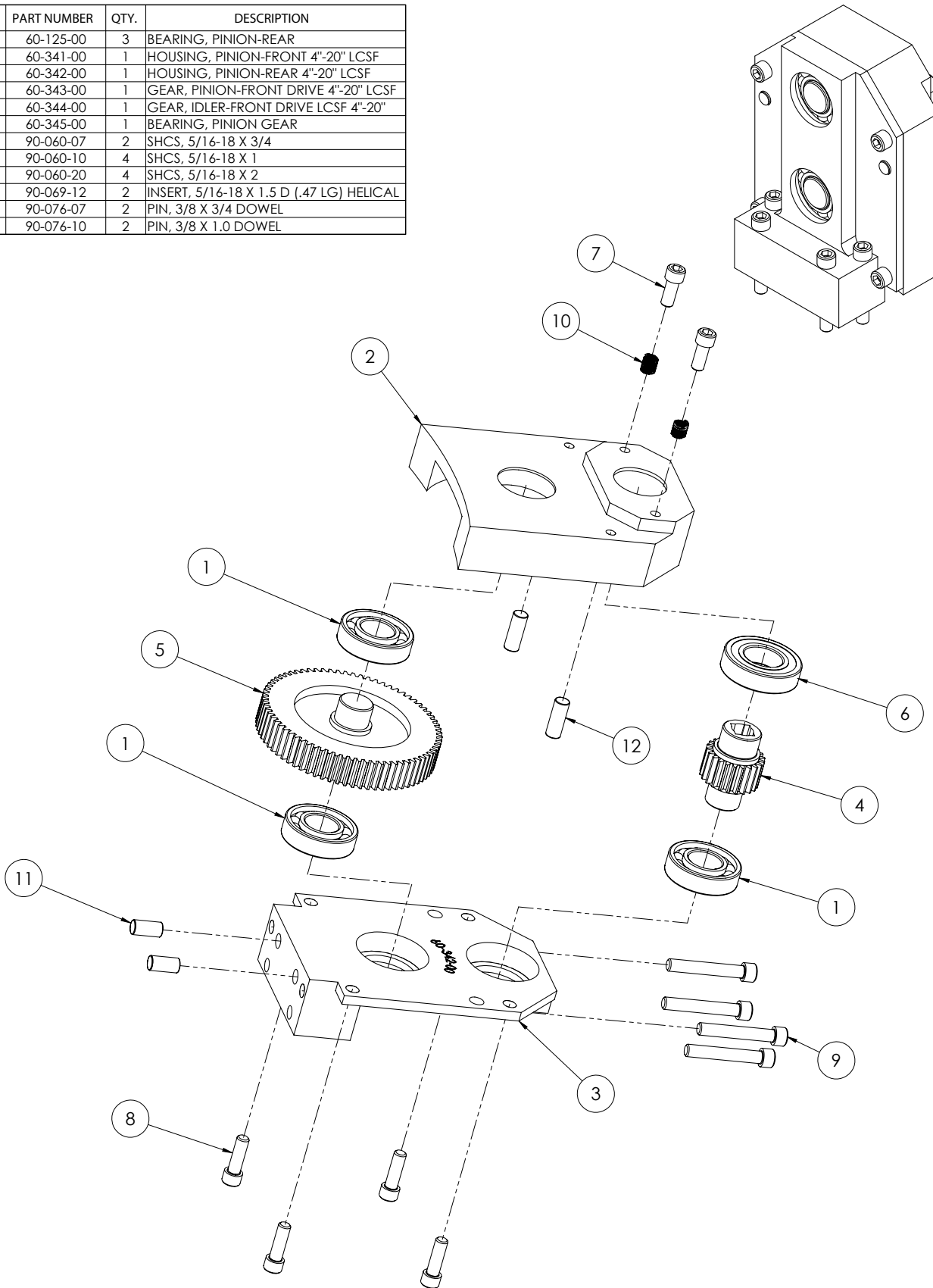

Clamp Legs, 60-127-XX

ITEM	PART NUMBER	QTY.	DESCRIPTION
1	WHERE USED	1	EXTENSIONS, CLAMP PAD
2	90-060-05	2	SHCS, 5/16-18 X 1/2
3	90-065-09	2	NUT, 5/16 PUSH

-WHERE USED-				
ITEM	PART NUMBER	QTY.	DESCRIPTION	ASSEMBLY NUMBER
1	60-027-05	1	EXTENSIONS, CLAMP LEG	60-127-05
	60-027-07			60-127-07
	60-027-10			60-127-10
	60-027-15			60-127-15
	60-027-20			60-127-20
	60-027-25			60-127-25
	60-027-28			60-127-28
	60-027-30			60-127-30
	60-027-31			60-127-31
	60-027-35			60-127-35
	60-027-40			60-127-40

ORDERING NUMBERS		
INDIVIDUAL CLAMP PADS	SIZE	CLAMP PAD SETS (QTY. 4)
60-127-05	0.5"	60-408-05
60-127-07	0.75"	60-408-07
60-127-10	1.0"	60-408-10
60-127-15	1.5"	60-408-15
60-127-20	2.0"	60-408-20
60-127-25	2.5"	60-408-25
60-127-28	2.8"	60-408-28
60-127-30	3.0"	60-408-30
60-127-31	3.1"	60-408-31
60-127-35	3.5"	60-408-35
60-127-40	4.0"	60-408-40

NOTE: LCSF models 204 through 1420 have 4 clamp legs.
See clamp leg charts in Chapter 5 for pipe size configurations.

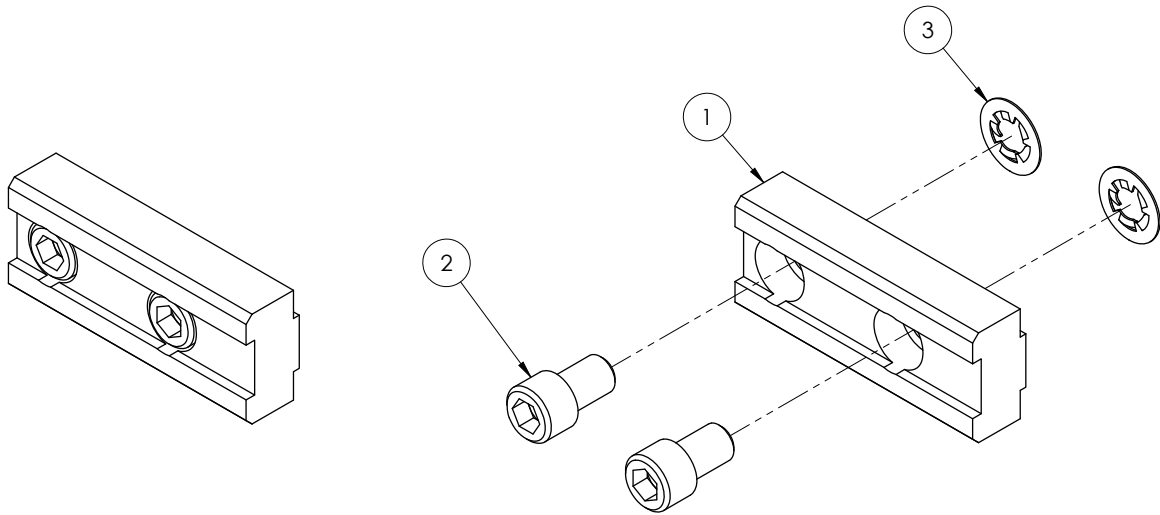

Trip Assembly, 60-401-00

ITEM	PART NUMBER	QTY.	DESCRIPTION
1	60-107-00	1	BLOCK, HOUSING-TRIP PIN
2	60-338-00	1	PIN, TRIP
3	60-1048-00	1	SPOOL
4	60-1049-00	1	LEVER
5	60-1050-00	1	QUICK PIN
6	90-026-55	1	1/8" X 1/2" PIN
7	90-055-04	1	NUT, 1/4-20 JAM
8	90-059-08	1	SPRING PLUNGER
9	90-060-07	3	SHCS, 5/16-18 X 3/4
10	90-060-17	3	SHCS, 5/16-18 X 1-3/4 (NOT SHOWN)

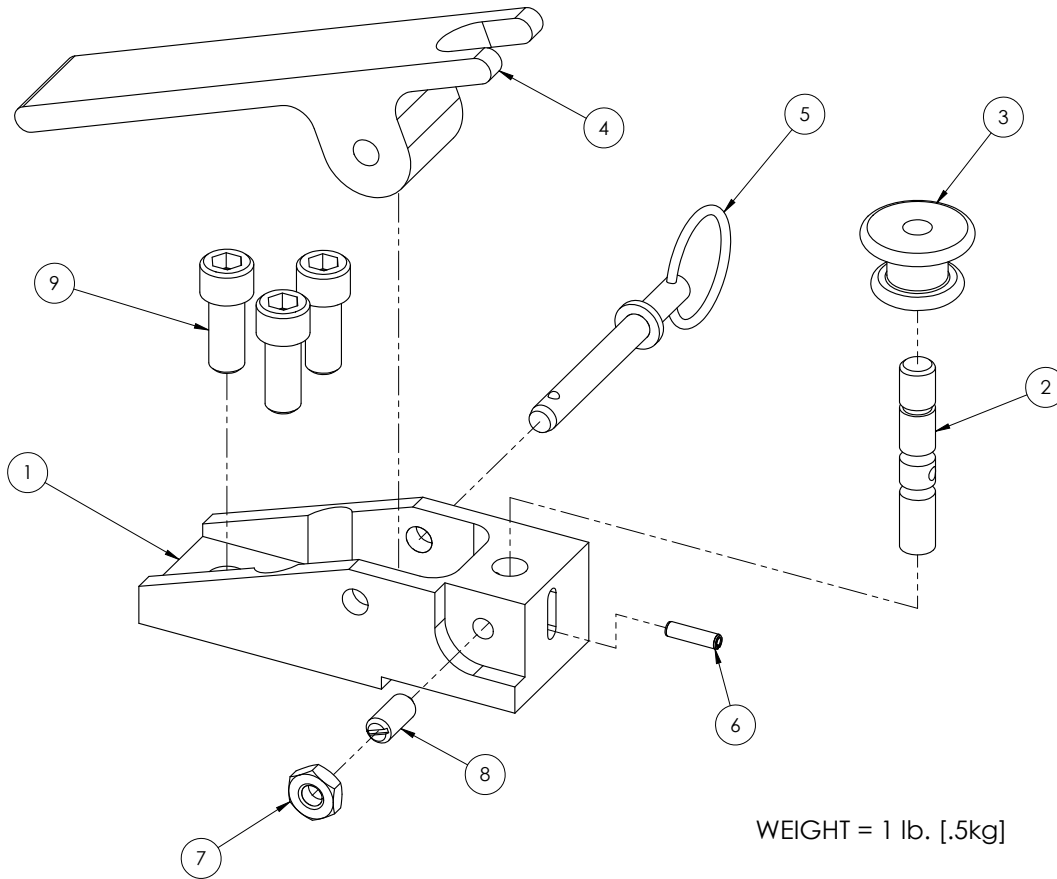
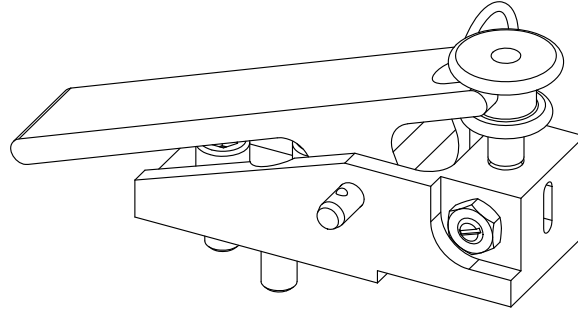

Low Clearance Parting Slide, 60-402-04

ITEM	PART NUMBER	QTY.	DESCRIPTION
1	60-110-04	1	SUPPORT, TOOL SLIDE-4,6,8
2	60-111-04	1	PLATE, WEAR-4,6,8
3	60-112-04	1	DOVETAIL, ADJUSTABLE-4,6,8
4	60-113-04	1	DOVETAIL, FIXED-4,6,8
5	60-114-00	1	SLIDE, MALE-PARTING
6	60-116-00	1	NUT, FEED (STARWHEEL)
7	60-117-00	1	COVER, TOOL SLIDE
8	60-118-04	1	SCREW, FEED (STARWHEEL)
9	60-119-00	1	PLATE ASSEMBLY, FEED SCREW
10	90-050-05	2	SHCS, 1/4-20 X 1/2
11	90-050-08	4	SHCS, 1/4-20 X 7/8
12	90-054-05	1	SSS, 1/4-20 X 1/2
13	90-054-08	1	SSS, 1/4-20 X 7/8
14	90-055-04	1	NUT, 1/4-20 JAM
15	90-056-12	2	PIN, 1/4 X 1-1/4 DOWEL
16	90-059-05	2	LH SHCS, 1/4-20 X 1/2
17	90-059-23	10	INSERT, 1/4-20 x 1-1/2D (.38 LG) HELICAL
18	90-060-12	4	SHCS, 5/16-18 X 1-1/4
19	90-065-09	2	NUT, 5/16 PUSH
20	90-076-07	2	PIN, 3/8 X 3/4 DOWEL
21	90-060-08	3	SHCS, 5/16-18 X 7/8

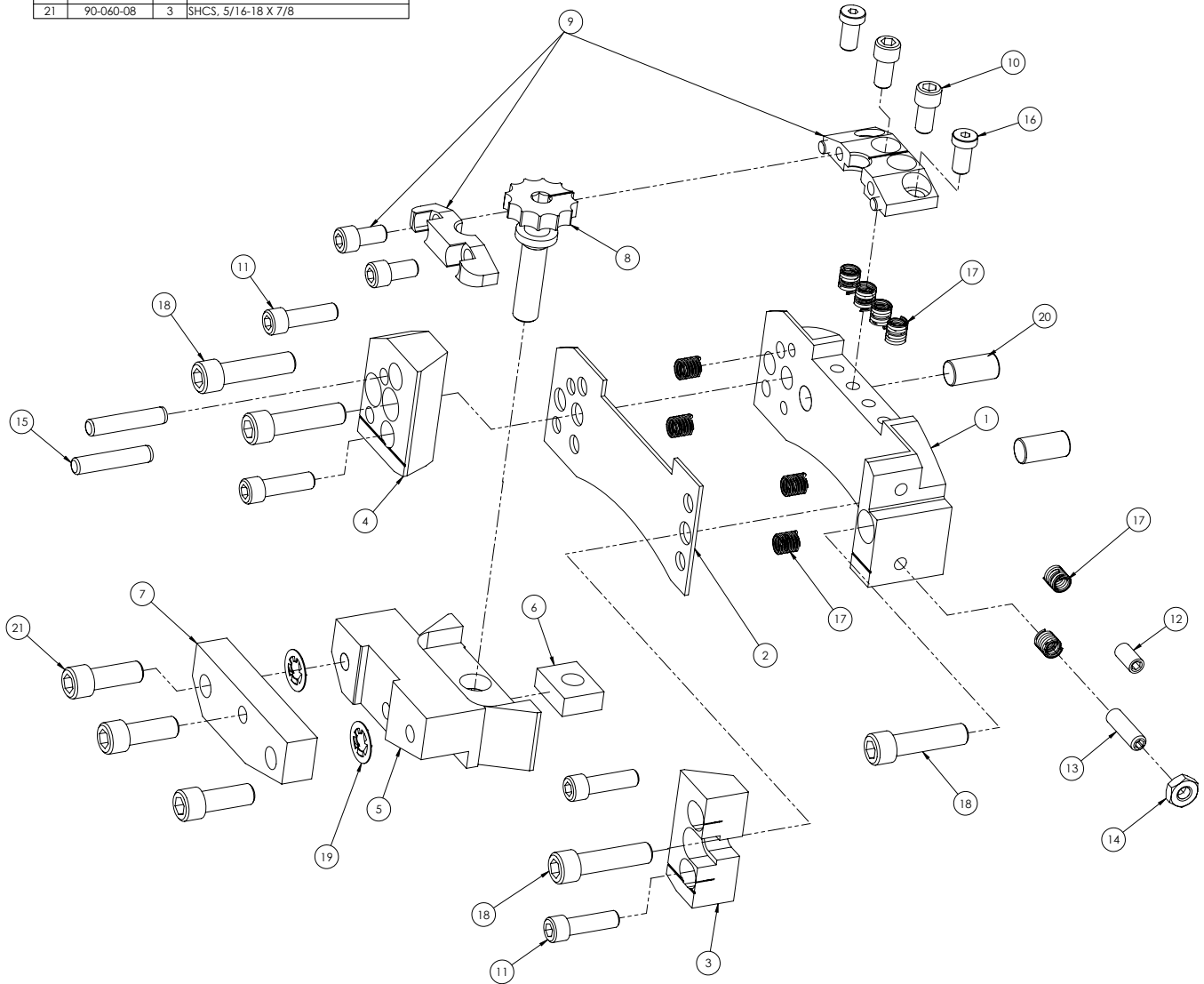
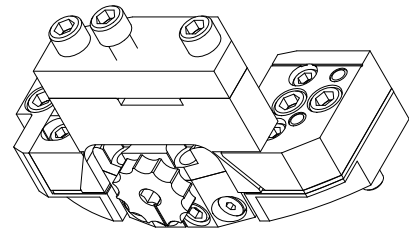

Low Clearance Beveling Slide, 60-403-04

ITEM	PART NUMBER	QTY.	DESCRIPTION
1	60-110-04	1	SUPPORT, TOOL SLIDE-4,6,8
2	60-111-04	1	PLATE, WEAR-4,6,8
3	60-112-04	1	DOVETAIL, ADJUSTABLE-4,6,8
4	60-113-04	1	DOVETAIL, FIXED-4,6,8
5	60-115-00	1	SLIDE, MALE-FORM TOOL
6	60-116-00	1	NUT, FEED (STARWHEEL)
7	60-117-00	1	COVER, TOOL SLIDE
8	60-118-04	1	SCREW, FEED (STARWHEEL)
9	60-119-00	1	PLATE ASSEMBLY, FEED SCREW
10	60-184-00	1	COVER, DBL. BEVEL
11	90-050-05	2	SHCS, 1/4-20 X 1/2
12	90-050-08	4	SHCS, 1/4-20 X 7/8
13	90-054-05	1	SSS, 1/4-20 X 1/2
14	90-054-08	1	SSS, 1/4-20 X 7/8
15	90-055-04	2	NUT, 1/4-20 JAM
16	90-056-12	2	PIN, 1/4 X 1-1/4 DOWEL
17	90-059-05	2	LH SHCS, 1/4-20 X 1/2
18	90-059-19	1	INSERT, 1/4-20 x 1D (.25 LG) HELICAL
19	90-059-23	9	INSERT, 1/4-20 x 1-1/2D (.38 LG) HELICAL
20	90-060-08	4	SHCS, 5/16-18 X 7/8
21	90-060-12	5	SHCS, 5/16-18 X 1-1/4
22	90-060-17	2	SHCS, 5/16-18 X 1-3/4 (NOT SHOWN)
23	90-065-09	4	NUT, 5/16 PUSH
24	90-076-07	2	PIN, 3/8 X 3/4 DOWEL

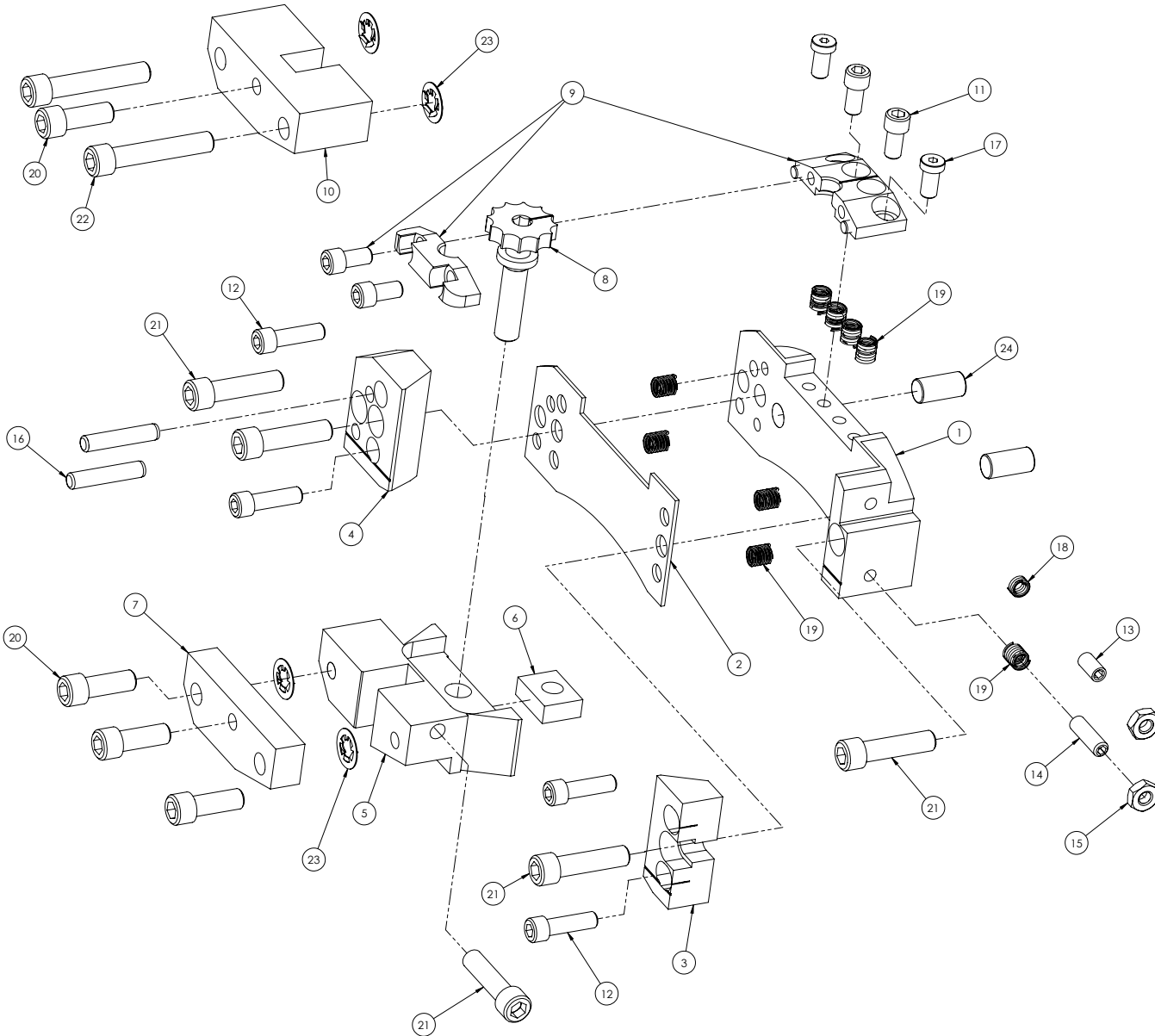
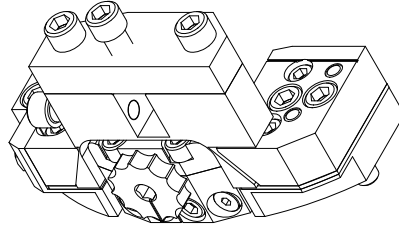

Extended Parting Slide, 60-415-00

ITEM	PART NUMBER	QTY.	DESCRIPTION
1	60-119-00	1	PLATE ASSEMBLY, FEED SCREW
2	60-188-01	1	SUPPORT, TOOL SLIDE
3	60-189-00	1	PLATE, WEAR (H.D.)
4	60-190-00	1	DOVETAIL, ADJUSTABLE (H.D.)
5	60-191-00	1	DOVETAIL, FIXED (H.D.)
6	60-192-00	1	SLIDE, MALE-PARTING (H.D.)
7	60-194-00	1	COVER, TOOL SLIDE (H.D.)
8	60-195-00	1	SCREW, FEED (H.D.)
9	60-196-00	2	PIN, ALIGNMENT
10	60-229-00	1	NUT, FEED (H.D. STAR-FEED)
11	90-050-05	2	SHCS, 1/4-20 X 1/2
12	90-050-08	8	SHCS, 1/4-20 X 7/8
13	90-054-08	4	SSS, 1/4-20 X 7/8
14	90-055-04	4	NUT, 1/4-20 JAM
15	90-056-12	2	PIN, 1/4 X 1-1/4 DOWEL
16	90-059-05	2	LH SHCS, 1/4-20 X 1/2
17	90-060-12	4	SHCS, 5/16-18 X 1-1/4
18	90-065-09	4	NUT, 5/16 PUSH
19	90-060-08	6	SHCS, 5/16-18 X 7/8

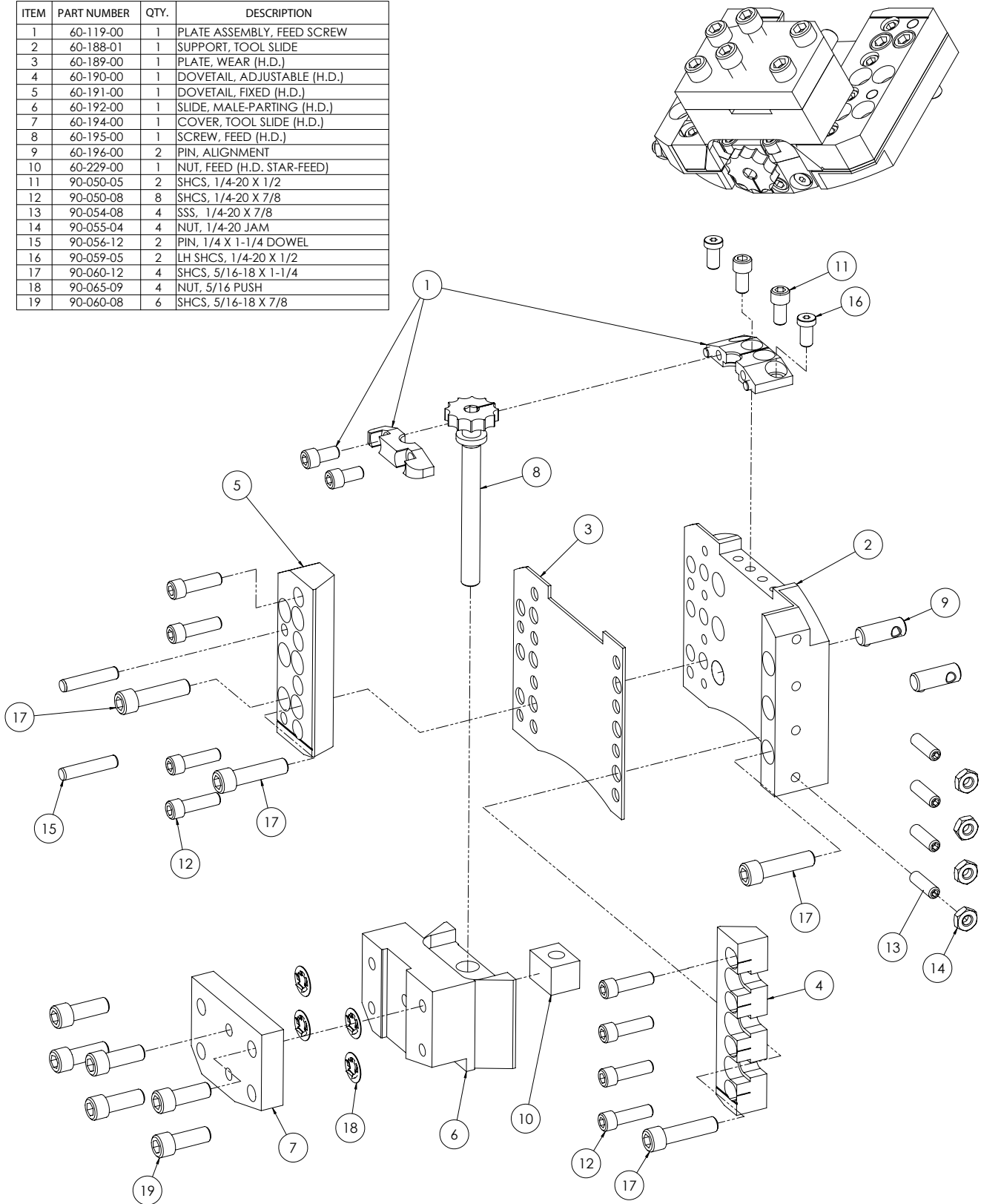

Extended Beveling Slide, 60-416-00

ITEM	PART NUMBER	QTY.	DESCRIPTION
1	60-119-00	1	PLATE ASSEMBLY, FEED SCREW
2	60-188-01	1	SUPPORT, TOOL SLIDE
3	60-189-00	1	PLATE, WEAR (H.D.)
4	60-190-00	1	DOVETAIL, ADJUSTABLE (H.D.)
5	60-191-00	1	DOVETAIL, FIXED (H.D.)
6	60-193-00	1	SLIDE, MALE FORM TOOL (H.D.)
7	60-194-00	1	COVER, TOOL SLIDE (H.D.)
8	60-195-00	1	SCREW, FEED (H.D.)
9	60-196-00	2	PIN, ALIGNMENT
10	60-214-00	1	COVER, H.D. DBL. BEVEL
11	60-229-00	1	NUT, FEED (H.D. STAR-FEED)
12	90-050-05	2	SHCS, 1/4-20 X 1/2
13	90-050-08	8	SHCS, 1/4-20 X 7/8
14	90-054-08	4	SSS, 1/4-20 X 7/8
15	90-055-04	4	NUT, 1/4-20 JAM
16	90-056-12	2	PIN, 1/4 X 1-1/4 DOWEL
17	90-059-05	2	LH SHCS, 1/4-20 X 1/2
18	90-060-12	5	SHCS, 5/16-18 X 1-1/4
19	90-060-17	4	SHCS, 5/16-18 X 1-3/4
20	90-065-09	8	NUT, 5/16 PUSH
21	90-060-08	8	SHCS, 5/16-18 X 7/8

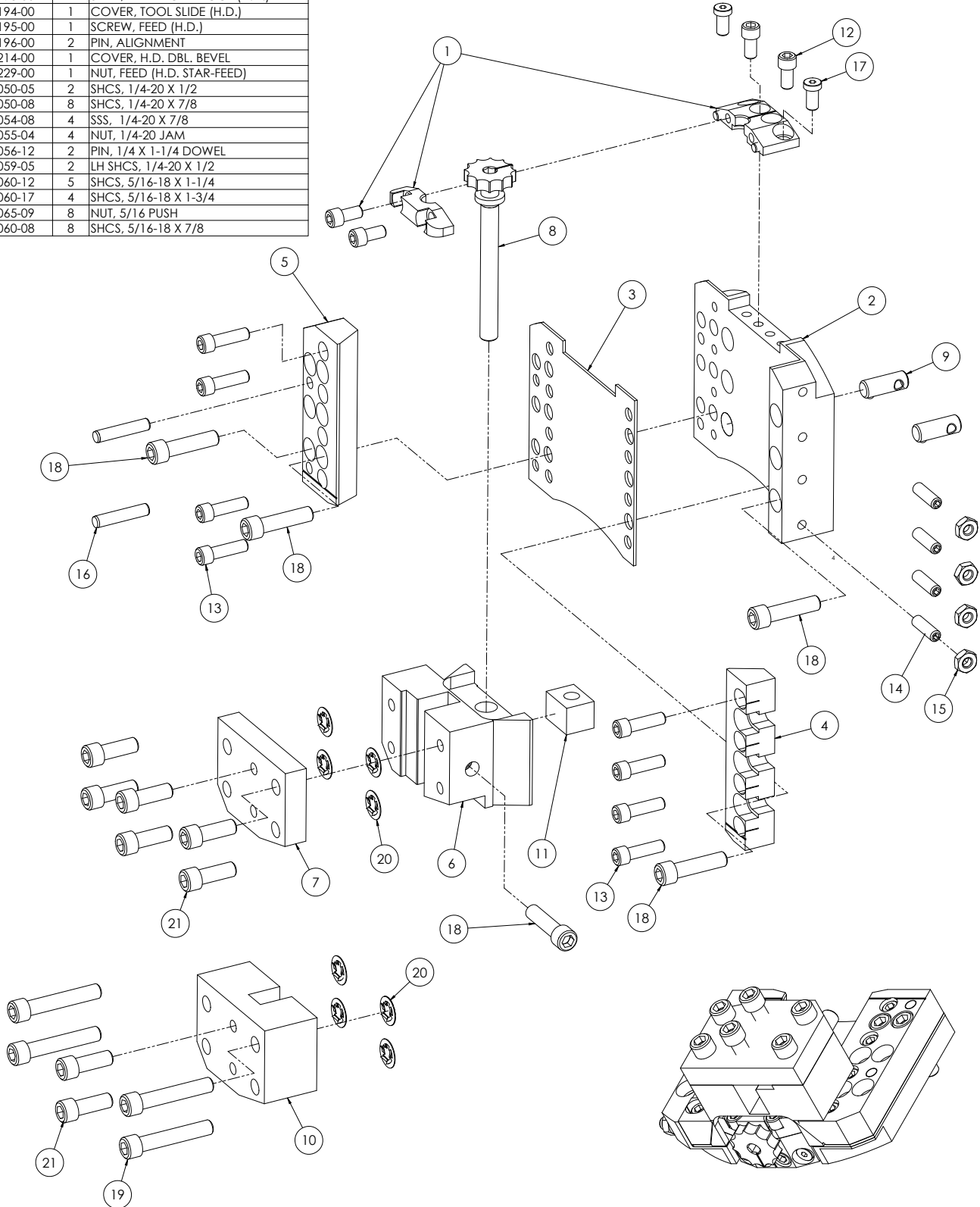

Universal Counterbore Slide, 60-405-UC

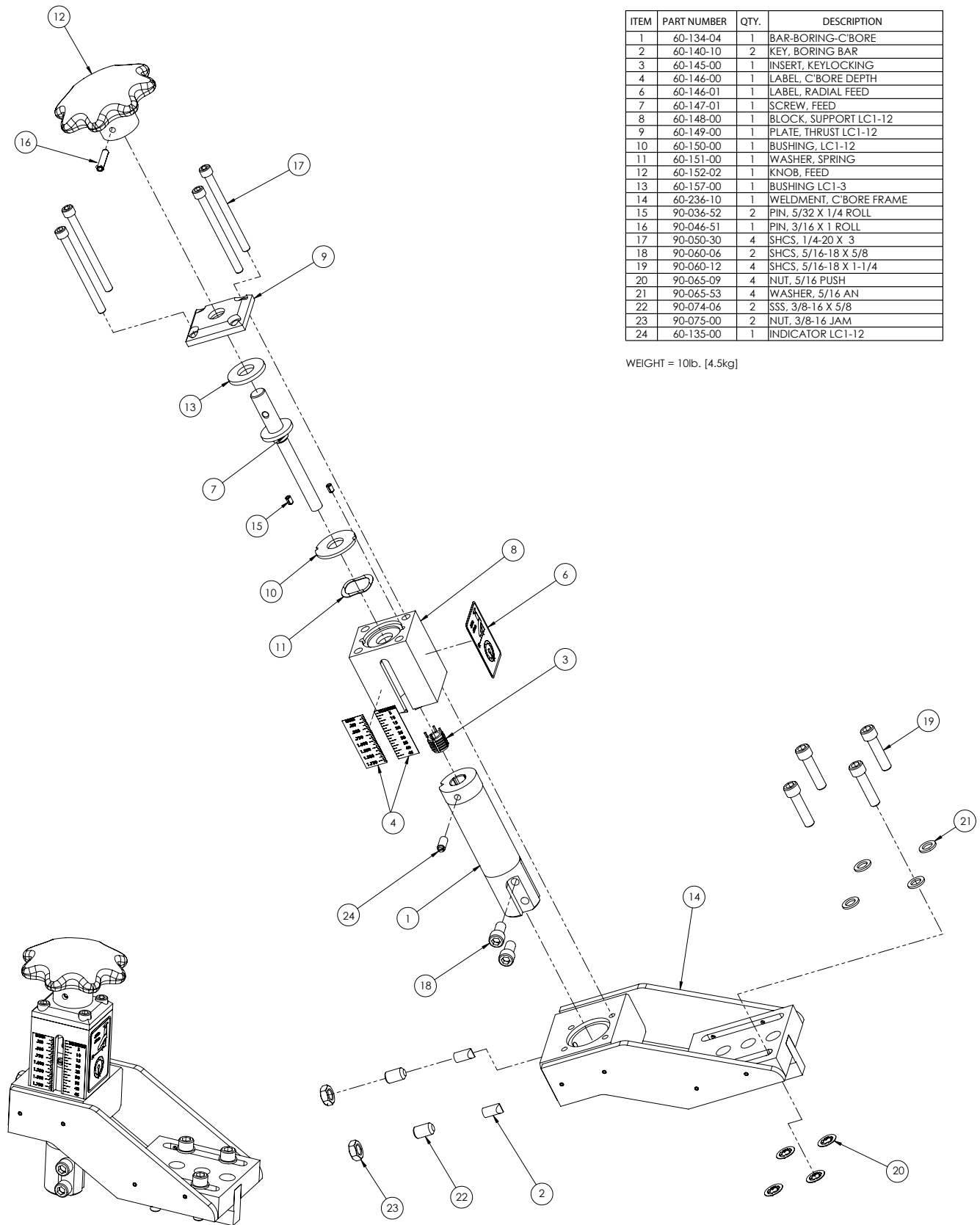

ITEM	PART NUMBER	QTY.	DESCRIPTION
1	60-134-04	1	BAR-BORING-C'BORE
2	60-140-10	2	KEY, BORING BAR
3	60-145-00	1	INSERT, KEYLOCKING
4	60-146-00	1	LABEL, C'BORE DEPTH
6	60-146-01	1	LABEL, RADIAL FEED
7	60-147-01	1	SCREW, FEED
8	60-148-00	1	BLOCK, SUPPORT LC1-12
9	60-149-00	1	PLATE, THRUST LC1-12
10	60-150-00	1	BUSHING, LC1-12
11	60-151-00	1	WASHER, SPRING
12	60-152-02	1	KNOB, FEED
13	60-157-00	1	BUSHING LC1-3
14	60-236-10	1	WELDMENT, C'BORE FRAME
15	90-036-52	2	PIN, 5/32 X 1/4 ROLL
16	90-046-51	1	PIN, 3/16 X 1 ROLL
17	90-050-30	4	SHCS, 1/4-20 X 3
18	90-060-06	2	SHCS, 5/16-18 X 5/8
19	90-060-12	4	SHCS, 5/16-18 X 1-1/4
20	90-065-09	4	NUT, 5/16 PUSH
21	90-065-53	4	WASHER, 5/16 AN
22	90-074-06	2	SSS, 3/8-16 X 5/8
23	90-075-00	2	NUT, 3/8-16 JAM
24	60-135-00	1	INDICATOR LC1-12

WEIGHT = 10lb. [4.5kg]

1.5 HP Air Drive, 60-423-00

ITEM NO.	PART NUMBER	DESCRIPTION	QTY.
1	05-082-00	OILER, AIR LINE	1
2	60-210-00	FLANGE, 1.5 HP CLECO-AIR	1
3	60-211-00	CLECO AIR MOTOR (55NL-3T-960)	1
3.1	CLE-201812	SUBASSY; HANDLE	1
3.1.1	CLE-202632	PAD; MUFFLER	1
3.1.2	CLE-203109	PAD; MUFFLER	1
3.1.3	CLE-202481	PIN; VALVE	1
3.1.4	CLE-202011	SEAL RING	1
3.1.5	CLE-617754	O-RING	2
3.1.6	CLE-202626	DEFLECTOR; EXHAUST	1
3.1.7	CLE-202055	THROTTLE VALVE	1
3.1.8	CLE-202508	INLET SPACER	1
3.1.9	CLE-864195	PIN; LEVER	1
3.1.10	CLE-869933	BUSHING; INLET	1
3.1.11	CLE-843656	SCREEN	1
3.1.12	CLE-864973	SPRING; THROTTLE VALVE	1
3.1.13	CLE-622062	O-RING	1
3.1.14	CLE-869931	SEAT; THROTTLE VALVE	1
3.1.15	CLE-622881	O-RING	1
3.1.16	CLE-203111	HANDLE - REVERSIBLE	1
3.1.17	CLE-832079	SPRING	1
3.1.18	CLE-203203	NUT, METERING	1
3.1.19	CLE-201638	SUBASSY; LOCKOFF LEVER	1
3.1.19.1	CLE-204178	LEVER; LOCKOFF	1
3.1.19.2	CLE-202105	TOGGLE	1
3.1.19.3	CLE-845409	PIN; SPRING	1
3.1.19.4	CLE-869855	SPRING; TOGGLE	1
3.2	CLE-201311	SUBASSY, GEAR TRAIN	1
3.2.1	CLE-201308	GEAR SPIDER	1
3.2.1.1	CLE-203105	2ND RED GEAR SPIDER	1
3.2.1.2	CLE-204809	2ND GEAR PIN (3/16 DOWEL)	3
3.2.1.3	CLE-203107	IDLER GEAR; 2ND RED.	3
3.2.1.3.1	CLE-203062	BUSHING	2
3.2.1.3.2	CLE-846659	GEAR 20T, IDLER GEAR	1
3.2.2	CLE-861485	SPIDER; OPEN	1

ITEM NO.	PART NUMBER	DESCRIPTION	QTY.
3.2.2.1	CLE-832125	IDLE GEAR PIN	3
3.2.2.2	CLE-867532	GEAR SPIDER	1
3.2.3	CLE-867526	GEAR; IDLER	3
3.2.3.1	CLE-844774	BEARING; NEEDLE (B-36)	1
3.2.4	CLE-867544	GEAR CASE (50T)	1
3.3	CLE-203101	CYLINDER	1
3.3.1	CLE-863887	PIN; SLOTTED SPRING	1
3.4	CLE-203102	ROTOR	1
3.5	CLE-843444	BEARING; BALL	1
3.6	CLE-861496	HEAD, ANGLE (T-4)	1
3.6.1	CLE-867507	ANGLE HEAD; LONG HEAVY DUTY	1
3.6.2	CLE-842517	BALL BEARING	1
3.6.3	CLE-867511	PINION	1
3.6.4	CLE-867512	GEAR	1
3.6.5	CLE-867546	PLUG, PIPE	1
3.6.6	CLE-867547	BALL BEARING	1
3.6.7	CLE-867548	BEARING	1
3.6.8	CLE-882661	NEEDLE BEARING	1
3.6.9	CLE-207288	SPINDLE, 1/2" SQ. DRIVE	1
3.7	CLE-865352	ROTOR LOCK NUT	1
3.8	CLE-867520	PLATE, MAKE-UP	1
3.9	CLE-867521	LOCK NUT	1
3.10	CLE-867522	SNAP RING	2
3.11	CLE-867528	MOTOR MAKE UP PLATE	1
3.12	CLE-867536	PLATE; FRONT BEARING	1
3.13	CLE-869569	ROTOR BLADE	5
3.14	CLE-869572	PLATE; REAR BEARING	1
3.15	CLE-203989	BEARING CAP	1
3.16	CLE-619377	BEARING	1
3.17	CLE-382633	PROTECTOR, SPLINE	1
4	66-100-00	VALVE; SPEED CONTROL	1
5	90-098-01	NIPPLE, 1/2 CLOSE LP BLACK	2
6	90-403-00	LABEL, BURN HAZARD/HOT SURFACE	1
7	90-401-02	LABEL, PRESSURE-AIR	1
8	90-401-03	LABEL, EAR AND EYE PROTECTION	1

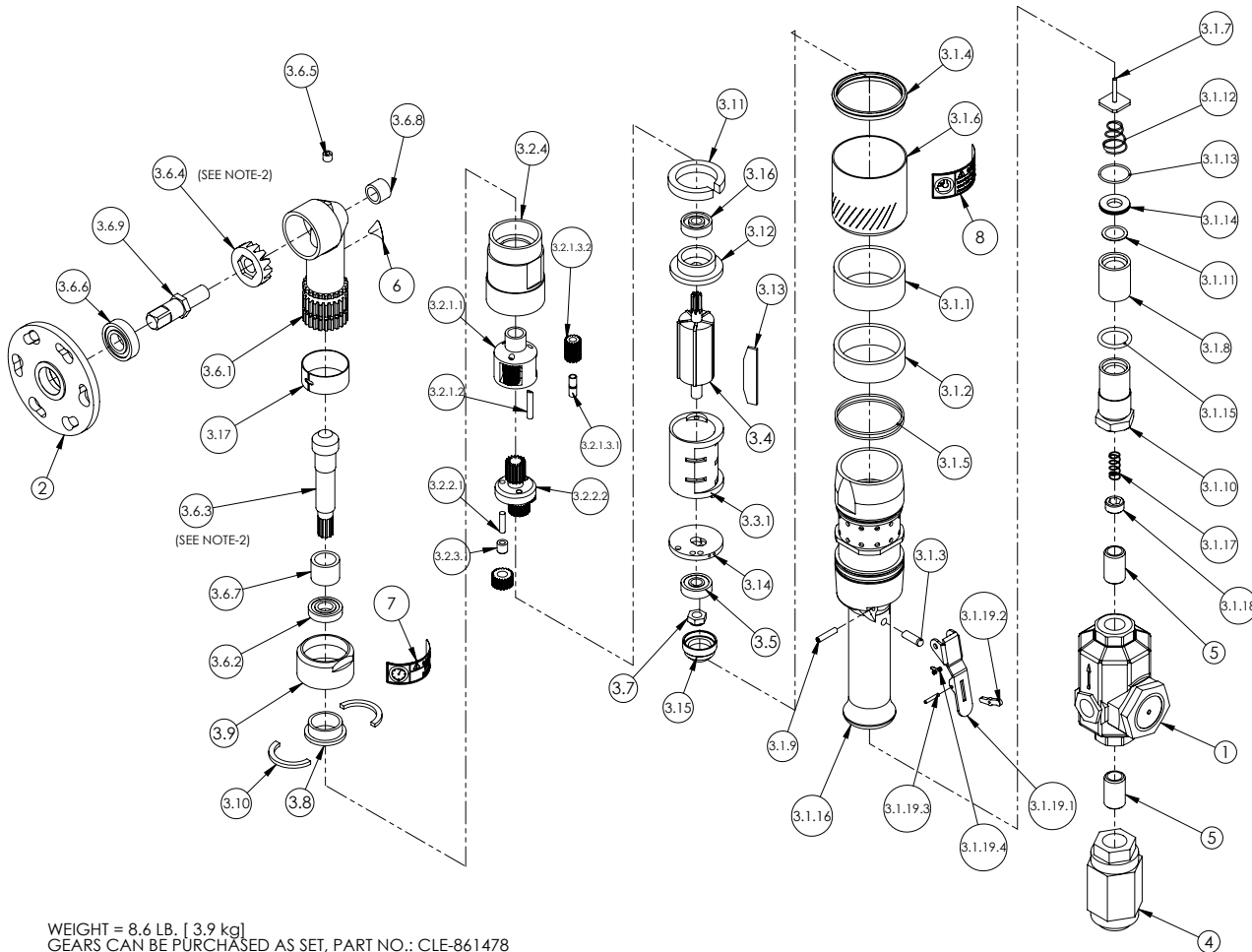

WEIGHT = 8.6 LB. [3.9 kg]
 GEARS CAN BE PURCHASED AS SET, PART NO.: CLE-861478

1.5 HP Air Drive, Ported Exhaust, 60-407-00

ITEM NO.	PART NUMBER	DESCRIPTION	QTY.
1	60-211-00	CLECO AIR MOTOR (55NL-3T-960)	1
1.1	CLE-201812	SUBASSY; HANDLE	1
1.1.1	CLE-202632	PAD; MUFFLER	1
1.1.2	CLE-203109	PAD; MUFFLER	1
1.1.3	CLE-202481	PIN; VALVE	1
1.1.4	CLE-202011	SEAL; RING	1
1.1.5	CLE-617754	O-RING	2
1.1.7	CLE-202055	THROTTLE VALVE	1
1.1.8	CLE-202508	INLET SPACER	1
1.1.9	CLE-864195	PIN; LEVER	1
1.1.10	CLE-869933	BUSHING; INLET	1
1.1.11	CLE-843656	SCREEN	1
1.1.12	CLE-864973	SPRING; THROTTLE VALVE	1
1.1.13	CLE-622062	O-RING	1
1.1.14	CLE-869931	SEAT; THROTTLE VALVE	1
1.1.15	CLE-622881	O-RING	1
1.1.16	CLE-203111	HANDLE - REVERSIBLE	1
1.1.17	CLE-201638	SUBASSY; LOCKOFF LEVER	1
1.1.17.1	CLE-204178	LEVER; LOCKOFF	1
1.1.17.2	CLE-202105	TOGGLE	1
1.1.17.3	CLE-867509	PIN; SPRING	1
1.1.17.4	CLE-869885	SPRING; TOGGLE	1
1.1.18	CLE-832079	SPRING	1
1.1.19	CLE-203203	NUT; METERING	1
1.2	CLE-201311	SUBASSY; GEAR TRAIN	1
1.2.1	CLE-201308	GEAR SPIDER	1
1.2.1.1	CLE-203105	2ND RED GEAR SPIDER	1
1.2.1.2	CLE-204809	2ND GEAR PIN (3/16 DO WEL)	3
1.2.1.3	CLE-203107	IDLER GEAR; 2ND RED.	3
1.2.1.3.1	CLE-203062	BUSHING	2
1.2.1.3.2	CLE-846659	GEAR 20T, IDLER GEAR	1
1.2.2	CLE-861485	SPIDER; OPEN	1
1.2.2.1	CLE-832125	IDLE GEAR PIN	3
1.2.2.2	CLE-867532	GEAR SPIDER	1
1.2.3	CLE-867526	GEAR; IDLER	3
1.2.3.1	CLE-844774	BEARING; NEEDLE (B-36)	1
1.2.4	CLE-867544	GEAR CASE (50T)	1
1.3	CLE-203101	CYLINDER	1
1.3.1	CLE-863887	PIN; SLOTTED SPRING	1
1.4	CLE-203102	ROTOR	1
1.5	CLE-843444	BEARING; BALL	1
1.6	CLE-861496	HEAD, ANGLE (T-4)	1
1.6.1	CLE-203097	ANGLE HEAD; LONG HEAVY DUTY	1
1.6.2	CLE-842517	BALL BEARING	1
1.6.3	CLE-867511	PINION	1
1.6.4	CLE-867512	GEAR	1
1.6.5	CLE-867546	PLUG; PIPE	1
1.6.6	CLE-867547	BALL BEARING	1
1.6.7	CLE-867548	BEARING	1
1.6.8	CLE-868261	NEEDLE BEARING	1
1.6.9	CLE-207888	SPINDLE; 1/2" SQ. DRIVE	1
1.7	CLE-845352	ROTOR LOCK NUT	1
1.8	CLE-867520	PLATE; MAKE-UP	1
1.9	CLE-867521	LOCK NUT	1
1.10	CLE-867522	SNAP RING	2
1.11	CLE-867528	MOTOR MAKE UP PLATE	1
1.12	CLE-867536	PLATE; FRONT BEARING	1
1.13	CLE-869569	ROTOR BLADE	5
1.14	CLE-869572	PLATE; REAR BEARING	1
1.15	CLE-203989	BEARING CAP	1
1.16	CLE-619377	BEARING	1
1.17	CLE-382633	PROTECTOR, SPLINE	1
2	60-210-00	FLANGE, T.5 HP CLECO-AIR	1
3	66-100-00	VALVE; SPEED CONTROL	1
4	90-098-01	NIFFLE; 1/2" LOSE LP BLACK	2
5	60-215-00	COLLECTOR; EXHAUST	1
6	05-082-00	OILER; AIR LINE	1

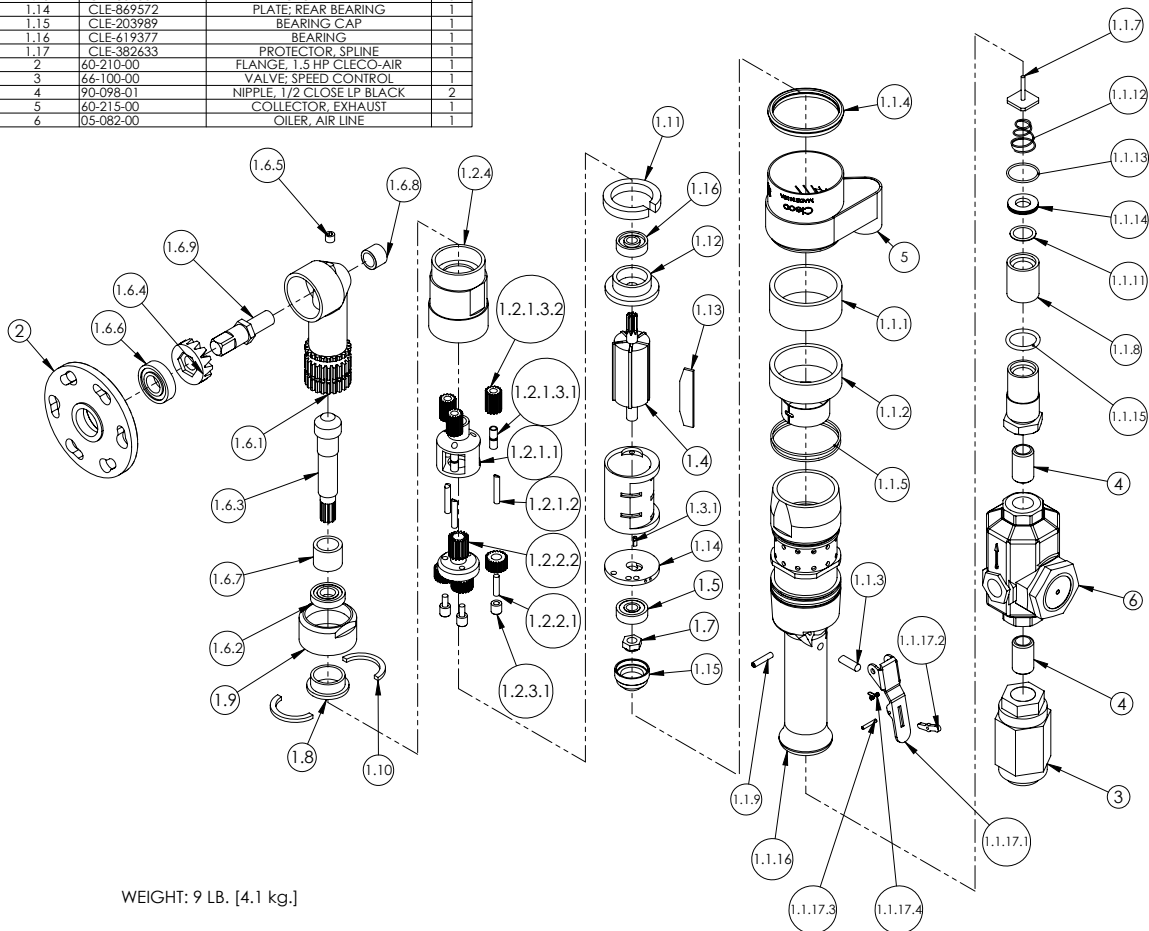
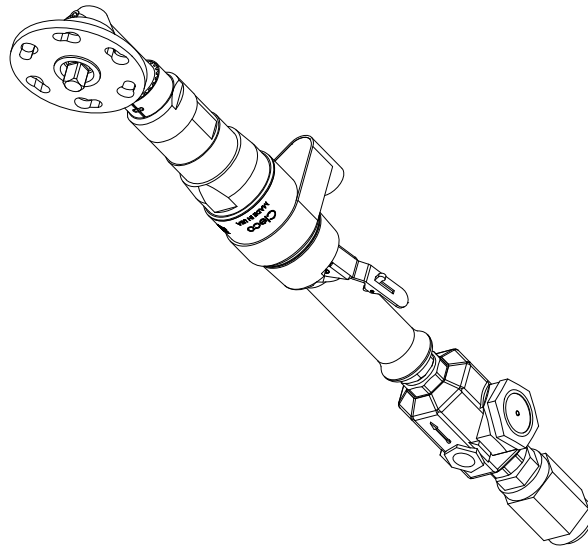

WEIGHT: 9 LB. [4.1 kg.]

2.5 HP Air Drive, 60-423-01

ITEM NO.	PART NUMBER	DESCRIPTION	QTY.
1	05-082-00	OILER AIR LINE	1
2	60-328-00	FLANGE, H.D. CLECO-MOTOR	1
3	60-329-00	CLECO AIR MOTOR - 75-NL-3V-959	1
3.1	CLE-201811	SUB ASSY. HANDLE - 230959	1
3.1.1	CLE-H203150	HANDLE	1
3.1.2	CLE-864195	PIN; LEVER	1
3.1.3	CLE-202481	PIN; VALVE	1
3.1.4	CLE-869943	MUFFLER	1
3.1.5	CLE-615018	O-RING	4
3.1.6	CLE-202050	SPACER, EXHAUST DEFLECTOR	1
3.1.7	CLE-202051	DEFLECTER, EXHAUST	1
3.1.8	CLE-869933	BUSHING; INLET	1
3.1.9	CLE-622581	O-RING	1
3.1.10	CLE-202508	INLET SPACER	1
3.1.11	CLE-843556	SCREEN	1
3.1.12	CLE-864973	SPRING; THROTTLE VALVE	1
3.1.13	CLE-202055	THROTTLE VALVE	1
3.1.14	CLE-622062	O-RING	1
3.1.15	CLE-869931	SEAT; THROTTLE VALVE	1
3.1.16	CLE-201638	SUBASSY; LOCKOFF LEVER	1
3.1.16.1	CLE-204178	LEVER; LOCKOFF	1
3.1.16.2	CLE-202105	TOGGLE	1
3.1.16.3	CLE-845409	PIN; SPRING	1
3.1.16.4	CLE-869855	SPRING; TOGGLE	1
3.2	CLE-203147	ROTOR	1
3.3	CLE-203149	CYLINDER	1
3.3.1	CLE-848909	CYLINDER CASTING	1
3.3.2	CLE-812918	PIN; CYLINDER	1
3.4	CLE-869927	ROTOR BLADE	5
3.5	CLE-869925	REAR BRG PLT	1
3.6	CLE-865352	ROTOR LOCK NUT	1
3.7	CLE-861914	SUBASSY; GEAR TRAIN (75-3)	1
3.7.1	CLE-869906	GEAR CASE 50T	1

ITEM NO.	PART NUMBER	DESCRIPTION	QTY.
3.7.2	CLE-869905	SPIDER; CAGE	1
3.7.3	CLE-869908	GEAR SHAFT	3
3.7.4	CLE-869907	NEEDLE ROLLER	39
3.7.5	CLE-869903	2ND RED IDGEAR	3
3.7.6	CLE-869898	OPEN SPIDER	1
3.7.6.1	CLE-869898-X	OPEN SPIDER CAST	1
3.7.6.2	CLE-832125	IDLE GEAR PIN	6
3.7.7	CLE-869900	IDLER GEAR 1ST RED IDL GR	3
3.7.7.1	CLE-866160	SEMI; IDLER GEAR	1
3.7.7.2	CLE-844774	BEARING; NEEDLE (B-36)	1
3.8	CLE-869923	FRONT BRG PLT	1
3.9	CLE-869929	SPACER; MOTOR	1
3.10	CLE-861904	SUBASM; RA HEAD (V-1/2 SQ)	1
3.10.1	CLE-869874	ANGLE HEAD	1
3.10.2	CLE-861903B	GEAR SET*	1
3.10.3	CLE-861903A	GEAR SET*	1
3.10.4	CLE-207289	1/2 S.D. SPINDLE	1
3.10.5	CLE-869882	BEARING	1
3.10.6	CLE-867546	PLUG; PIPE	1
3.10.7	CLE-869881	SPINDLE BEARING	1
3.10.8	CLE-847960	THRUST BRG	1
3.10.9	CLE-869877	BEARING RETAIN	1
3.10.10	CLE-847659	BEARING	1
3.11	CLE-869878	CLAMP NUT	1
3.12	CLE-869879	CLAMP RING	2
3.13	CLE-847528	BALL BEARING	1
3.14	CLE-847960	SET SCREW	1
4	66-100-00	VALVE; SPEED CONTROL	1
5	90-098-01	NIPPLE, 1/2 CLOSE LP BLACK	2
3.6	CLE-203989	BEARING CAP	1
7	90-403-00	LABEL, BURN HAZARD/HOT SURFACE	1
8	90-401-02	LABEL, PRESSURE-AIR	1
9	90-401-03	LABEL, EAR AND EYE PROTECTION	1

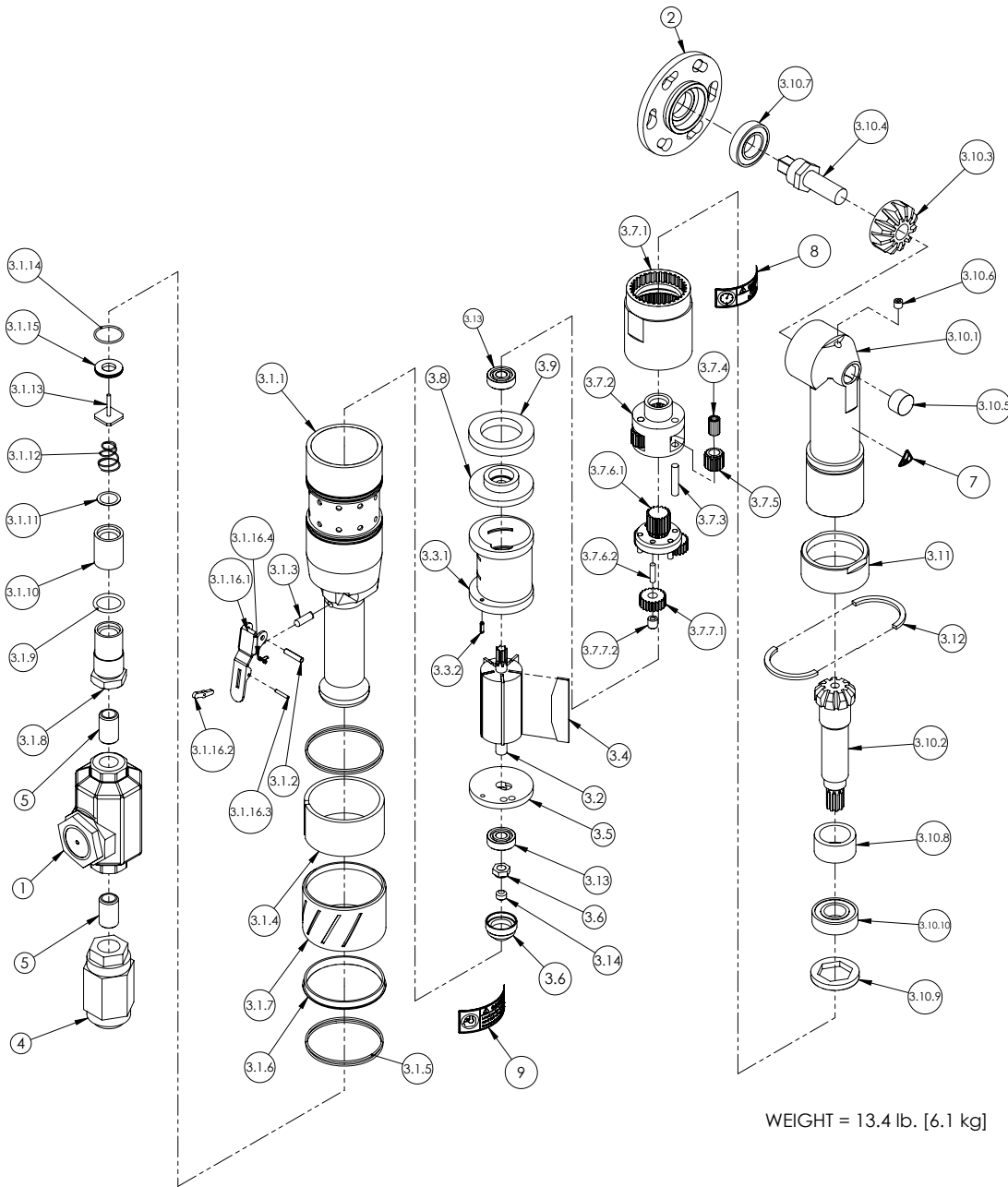

WEIGHT = 13.4 lb. [6.1 kg]

2.5 HP Reversible Air Drive, 60-4010-00

ITEM NO.	PART NUMBER	DESCRIPTION	QTY.
1	60-329-01	CLECO AIR MOTOR - 75RNL-4V-4	1
1.1	CLE-201330	SUBASSY; HANDLE	1
1.1.1	CLE-203151	HANDLE	1
1.1.2	CLE-202050	SPACER, EXHAUST DEFLECTOR	1
1.1.3	CLE-202051	DEFLECTER, EXHAUST	1
1.1.4	CLE-615018	O-RING	4
1.1.5	CLE-869943	MUFFLER	1
1.1.6	CLE-202055	THROTTLE VALVE	1
1.1.7	CLE-202508	INLET SPACER	1
1.1.8	CLE-622062	O-RING	1
1.1.9	CLE-843656	SCREEN	1
1.1.10	CLE-864973	SPRING; THROTTLE VALVE	1
1.1.11	CLE-869931	SEAT; THROTTLE VALVE	1
1.1.12	CLE-869933	BUSHING; INLET	1
1.1.13	CLE-202481	PIN; VALVE	1
1.1.14	CLE-864195	PIN; LEVER	1
1.1.15	CLE-865063	LEVER, THROTTLE	1
1.1.16	CLE-869942	REVERSE RING	1
1.1.17	CLE-847234	O-RING	1
1.1.18	CLE-867554	SCREW, REVERSING VALVE	1
1.1.19	CLE-869939	SPACER	1
1.1.20	CLE-869940	VALVE, REVERSING	1
1.1.21	CLE-617510	O-RING	1
1.1.22	CLE-622881	O-RING	1
1.2	CLE-203148	CYLINDER	1
1.2.1	CLE-848810	CYLINDER CASTING	1
1.2.2	CLE-812918	PIN, CYLINDER	1
1.3	CLE-203147	ROTOR	1
1.4	CLE-861913	SUBASM; GEAR TRAIN	1
1.4.1	CLE-869906	GEAR CASE 50T	1
1.4.2	CLE-869904	2ND RED SPIDER	1
1.4.3	CLE-869902	IDLER GEAR 2ND RED IDL GR	3

ITEM NO.	PART NUMBER	DESCRIPTION	QTY.
1.4.4	CLE-869907	NEEDLE ROLLER	39
1.4.5	CLE-869908	GEAR SHAFT	3
1.4.6	CLE-869897	1ST RED SPIDER	1
1.4.6.1	CLE-832125	IDLER GEAR PIN	6
1.4.6.2	CLE-869897-X	OPEN SPIDER CAST	1
1.4.7	CLE-869899	1ST RED IDLER GEAR (A&B)	3
1.4.7.1	CLE-844774	BEARING; NEEDLE (B-36)	1
1.4.7.2	CLE-869899-X	SEMI; IDLER GEAR	1
1.5	CLE-865352	ROTOR LOCK NUT	1
1.6	CLE-869901	1ST RED. PINION (A&B)	1
1.7	CLE-869923	FRONT BRG PLT	1
1.8	CLE-869928	REAR BRG PLATE	1
1.9	CLE-869929	SPACER, MOTOR	1
1.10	CLE-869927	ROTOR BLADE	5
1.11	CLE-861904	SUBASM; RA HEAD (V-1/2 SQ)	1
1.11.1	CLE-869874	ANGLE HEAD	1
1.11.2	CLE-861903B	GEAR SET*	1
1.11.3	CLE-861903A	GEAR SET*	1
1.11.4	CLE-207289	1/2 S.D. SPINDLE	1
1.11.5	CLE-869882	BEARING	1
1.11.6	CLE-867546	PLUG, PIPE	1
1.11.7	CLE-869881	SPINDLE BEARING	1
1.11.8	CLE-869880	THRUST BRG	1
1.11.9	CLE-869877	BEARING RETAIN	1
1.11.10	CLE-847659	BEARING	1
1.12	CLE-869879	CLAMP RING	2
1.13	CLE-869878	CLAMP NUT	1
1.14	CLE-847528	BALL BEARING	2
2	05-082-00	OILER, AIR LINE	1
3	60-328-00	FLANGE, H.D. CLECO-MOTOR	1
4	66-100-00	VALVE; SPEED CONTROL	1
5	90-098-01	NIPPLE, 1/2 CLOSE LP BLACK	2
6	90-403-00	LABEL, BURN HAZARD/HOT SURFACE	1

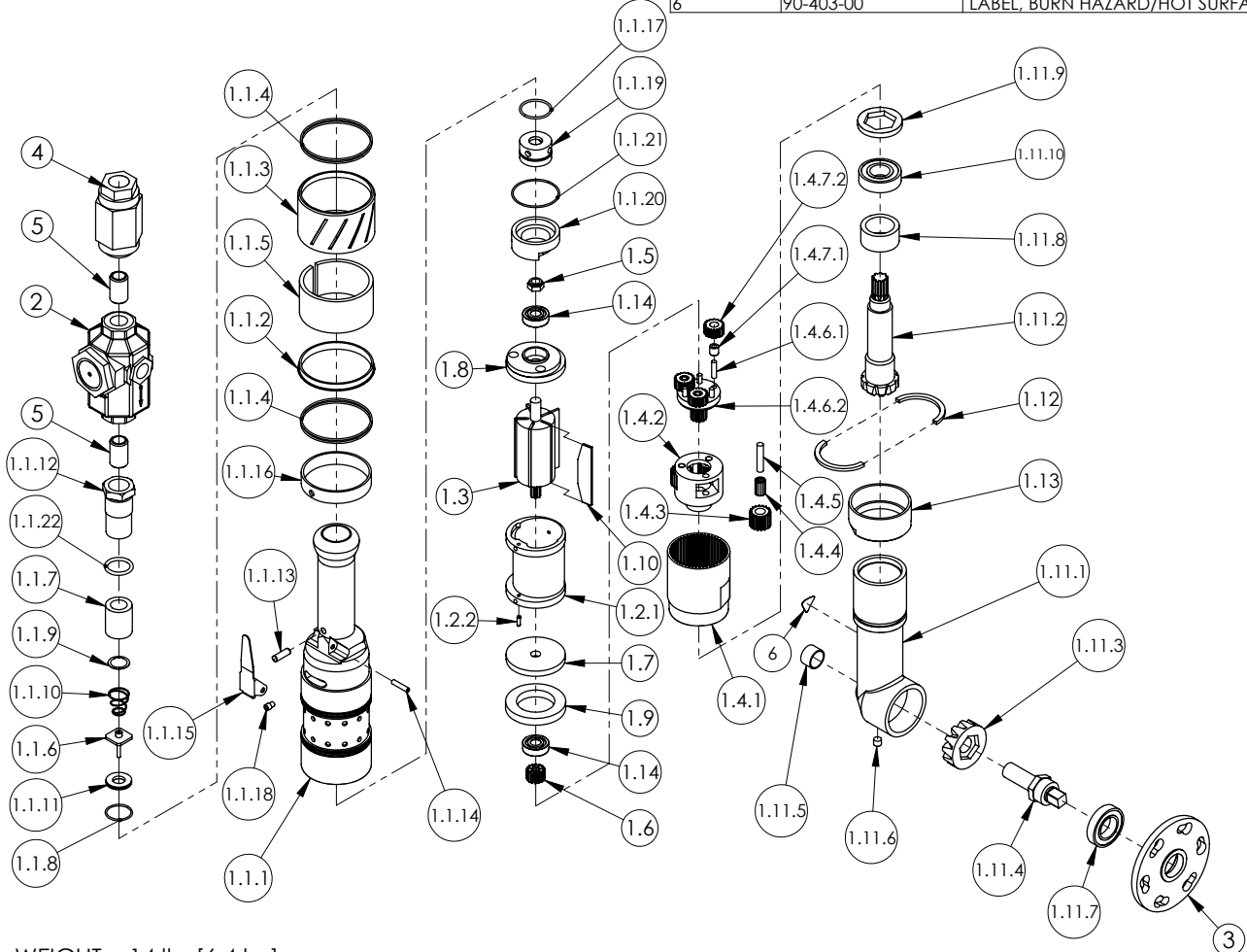

WEIGHT = 14 lb. [6.4 kg]

Hydraulic Drive, 60-424-02

ITEM	PART NUMBER	QTY	DESCRIPTION
1	02-199-00	1	MOTOR COUPLING, DRIVE PIN
2	02-203-00	1	ADAPTOR, DRIVE MOTOR
3	09-025-00	1	QUICK DISCONNECT, FEMALE
4	09-026-00	1	QUICK DISCONNECT-MALE
5	09-027-00	1	DUST CAP, MALE QUICK-DISCONNECT
6	09-028-00	1	DUST CAP, FEMALE QUICK-DISCONNECT
7	53-073-00	1	HYDRAULIC MOTOR
8	60-199-02	1	MANIFOLD
9	60-213-00	1	HYD. MOTOR MOUNT
10	76-175-00	1	RETAINING RING, 43/64
11	90-054-02	1	SSS, 1/4-20 x 1/4
12	90-059-48	0	1/4 x 1 (#808) WOODDRUFF KEY
13	90-060-12	2	SHCS, 5/16-18 X 1-1/4
14	90-061-20	4	HHCS 5/16-18 X 2
15	90-065-53	4	WASHER, 5/16 AN
16	90-078-67	0	O-RING -112
17	90-088-86	2	PLUG, -06 ZERO-LEAK ORB
18	90-090-15	2	SHCS, 1/2-13 X 1-1/2
19	90-098-79	2	ADAPTER, 1/2 NPT M X 1/2 ORB M - STRAIGHT
20	90-401-01	1	LABEL, EYE PROTECTION
21	90-402-01	1	LABEL, PRESSURE-HYD.
22	90-403-02	1	LABEL, BURN HAZARD/HOT SURFACE

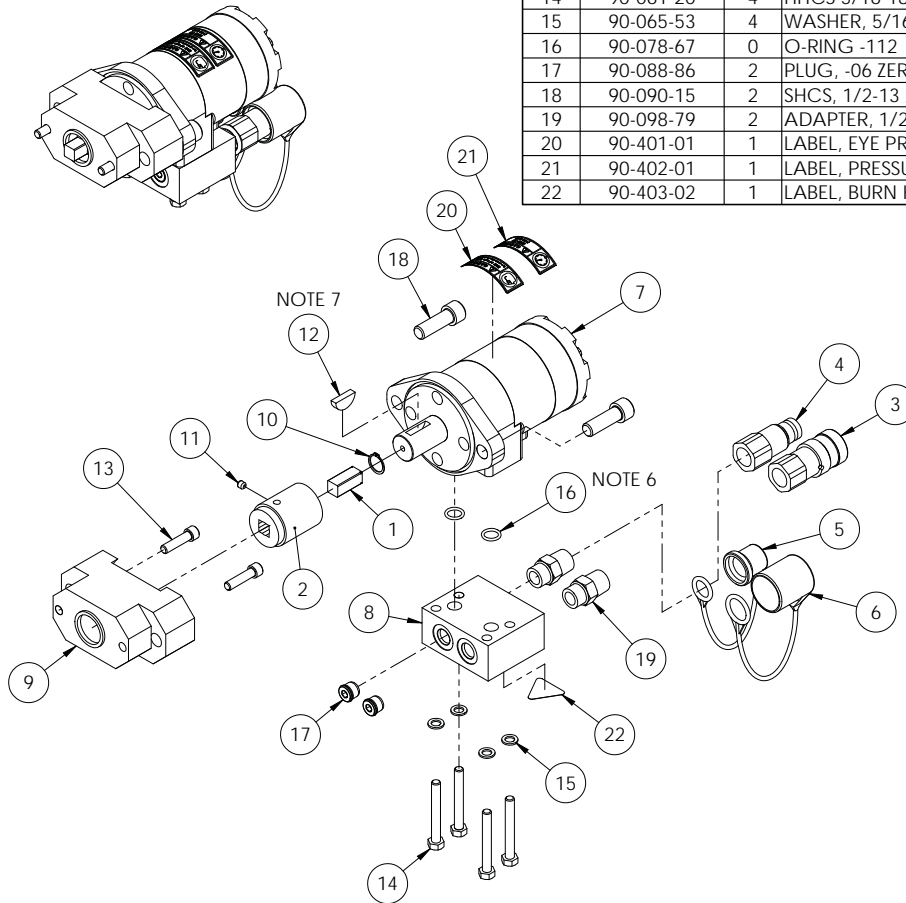

NOTES:

1. WARNING! - ASSEMBLY REQUIRES APPROVED HYDRAULIC POWER UNIT OR CONTROLS FOR SAFE LCSF OPERATION. SYSTEM INTEGRATOR RESPONSIBILITY
2. MUST ATTACH MOTOR MOUNT (ITEM 9) TO PINION HOUSING PRIOR TO MOUNTING HYDRAULIC MOTOR
3. MAX CONTINUOUS FLOW: 15 GPM [57 LPM]
4. MAX CONTINUOUS PRESSURE: 1650 PSI [114 BAR]
5. MAX INTERMITTENT PRESSURE (10% OF EVERY MINUTE): 2250 PSI [155 BAR]
6. (2) -112 O-RINGS (BUNA-N) INCLUDED WITH HYDRAULIC MOTOR 53-073-00
7. # 808 WOODRUFF KEY INCLUDED WITH MOTOR 53-073-00

Hydraulic Drive, 60-424-01 (OBSOLETE)

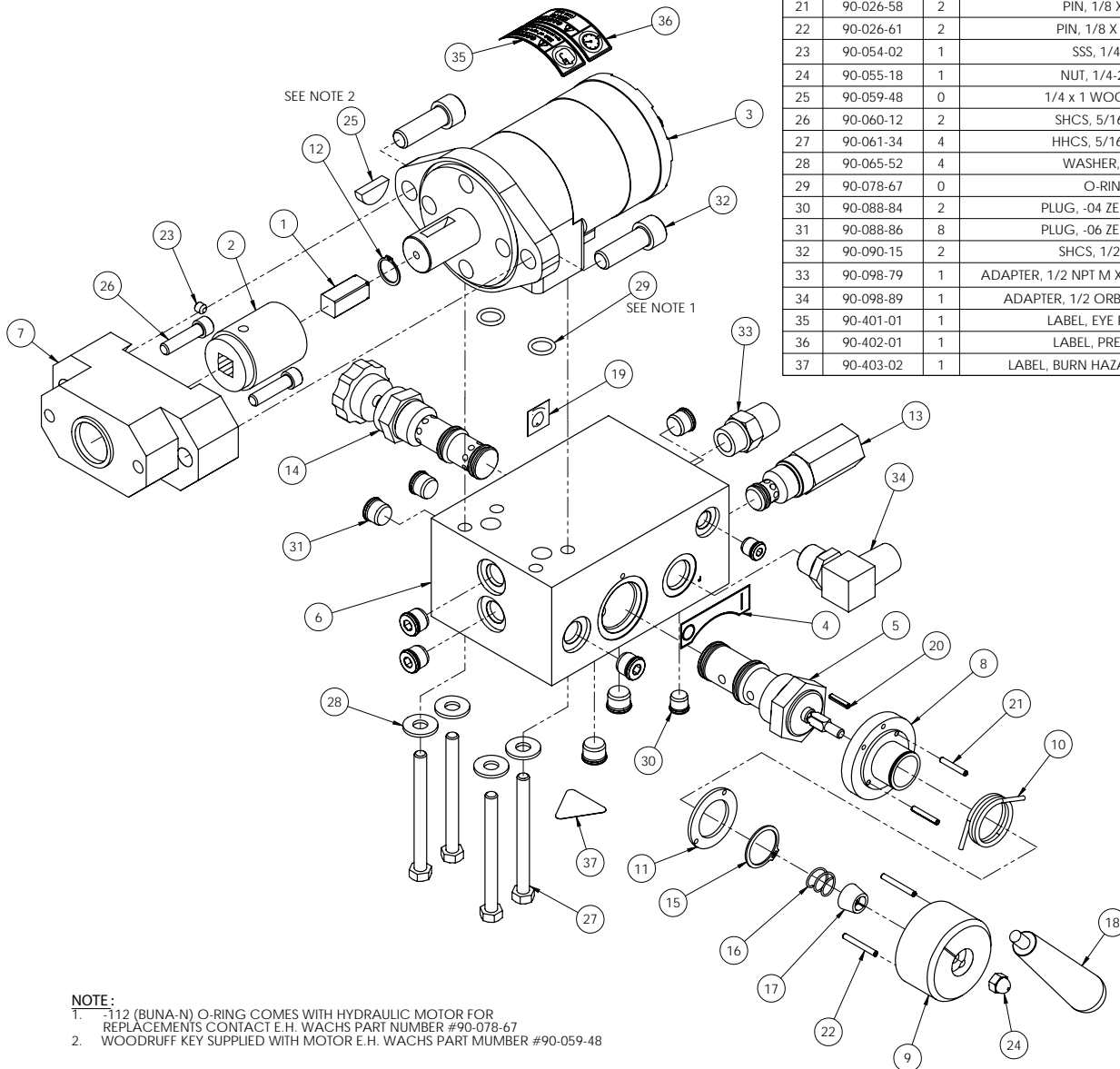
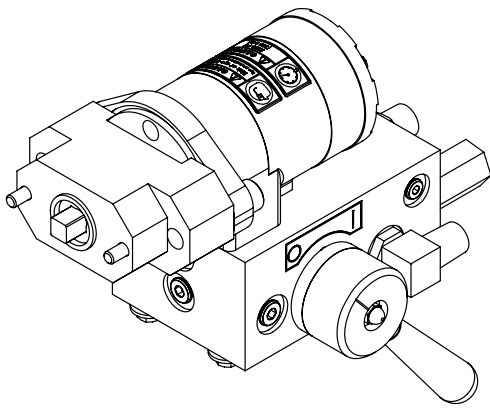

ITEM	PART NUMBER	QTY.	DESCRIPTION
1	02-199-00	1	MOTOR COUPLING, DRIVE PIN
2	02-203-00	1	ADAPTOR, DRIVE MOTOR
3	53-073-00	1	HYDRAULIC MOTOR
4	60-1186-00	1	LCSF FLOW DIRECTION LABEL
5	60-198-00	1	VALVE, MRV DIRECTIONAL CONTROL
6	60-199-00	1	MANIFOLD, SDB HYDRAULIC
7	60-213-00	1	HYD. MOTOR MOUNT
8	76-072-00	1	PLATE, MRV ANTI-ROTATION
9	76-073-00	1	CAP. MRV OPERATOR
10	76-074-00	1	SPRING, TORSION
11	76-075-00	1	PLATE, SPRING COVER
12	76-175-00	1	RETAINING RING, 43/64
13	76-176-00	1	VALVE, PRESSURE RELIEF
14	76-177-00	1	VALVE, PRESSURE COMPENSATED FLOW CONTROL
15	76-180-00	1	RING, 26MM EXT RETAINING
16	76-181-00	1	DETENT SPRING
17	76-182-00	1	SPACER
18	76-183-00	1	HANDLE, 5/16"-18
19	76-185-00	1	FLOW CONTROL LABEL
20	90-026-56	1	PIN, 1/8 x 5/8 ROLL
21	90-026-58	2	PIN, 1/8 X 7/8 ROLL
22	90-026-61	2	PIN, 1/8 X 1.125 ROLL
23	90-054-02	1	SSS, 1/4-20 x 1/4
24	90-055-18	1	NUT, 1/4-20 ACORN
25	90-059-48	0	1/4 x 1 WOODDRUFF KEY
26	90-060-12	2	SHCS, 5/16-18 X 1-1/4
27	90-061-34	4	HHCS, 5/16-18 X 3-1/2"
28	90-065-52	4	WASHER, 5/16 FLAT
29	90-078-67	0	O-RING -112
30	90-088-84	2	PLUG, -.04 ZERO-LEAK ORB
31	90-088-86	8	PLUG, -.06 ZERO-LEAK ORB
32	90-090-15	2	SHCS, 1/2-13 X 1-1/2
33	90-098-79	1	ADAPTER, 1/2 NPT M X 1/2 ORB M - STRAIGHT
34	90-098-89	1	ADAPTER, 1/2 ORB M X 1/2 NPT M - 90
35	90-401-01	1	LABEL, EYE PROTECTION
36	90-402-01	1	LABEL, PRESSURE-HYD.
37	90-403-02	1	LABEL, BURN HAZARD/HOT SURFACE

NOTE:
 1. -.112 (BUNA-N) O-RING COMES WITH HYDRAULIC MOTOR FOR REPLACEMENTS CONTACT E.H. WACHS PART NUMBER #90-078-67
 2. WOODRUFF KEY SUPPLIED WITH MOTOR E.H. WACHS PART NUMBER #90-059-48

Split Frame Air Control Module (60-420-00)

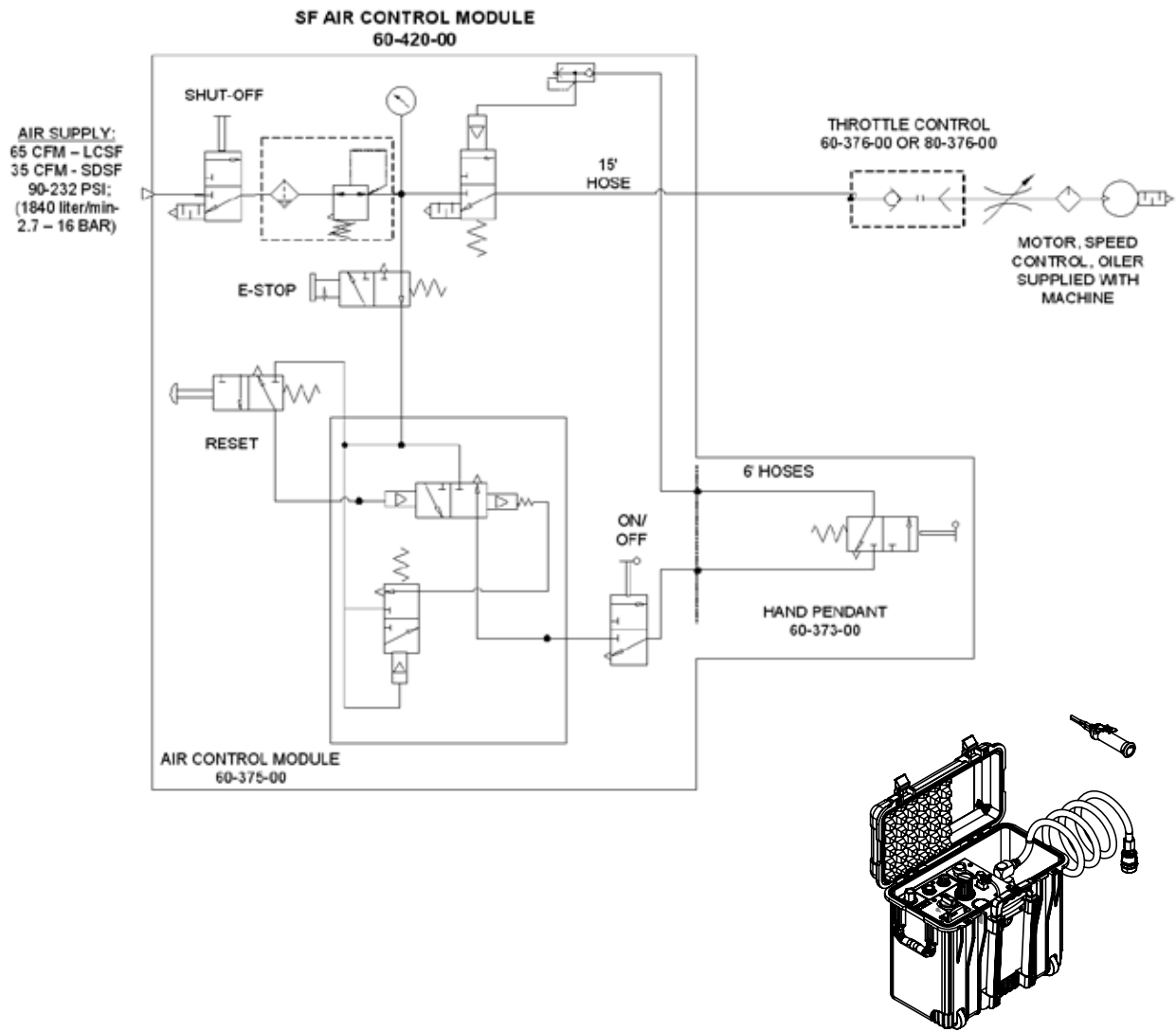

Air Control Module Subassembly (60-375-00)

ITEM	PART NUMBER	QTY	DESCRIPTION
1	60-1283-00	1	FILTER, PRESSURE REGULATOR
2	60-1284-00	1	VALVE, 3/2-SHUT-OFF
3	60-1285-00	1	3/2 DIR DUMP VALVE- PNEUM OPERATED
4	60-1286-00	2	BECK ASSEMBLY
5	60-1287-00	1	CASES OPERATOR PLATE
6	60-1291-00	2	A33 BRACKET
7	60-1292-00	1	CASE, 1440
8	60-1293-00	1	LABEL, STOP BACKGROUN
9	60-1294-00	1	LABEL, STOP BACKGROUN
10	60-1295-00	1	LABEL, STOP BACKGROUN
11	60-1296-00	1	LABEL, STOP BACKGROUN
12	60-1297-00	1	NO AIR SPOOL VALVE
13	60-1298-00	2	NC AIR SPOOL VALVE
14	60-1299-00	1	MANIFOLD, AIR
15	60-1300-00	1	MANIFOLD, AIR
16	60-1301-00	1	MANIFOLD, AIR
17	60-1302-00	1	MANIFOLD, AIR
18	60-1303-00	1	MANIFOLD, AIR
19	60-1304-00	1	MANIFOLD, AIR
20	60-1305-00	1	MANIFOLD, AIR
21	60-1306-00	1	MANIFOLD, AIR
22	60-1307-00	1	MANIFOLD, AIR
23	60-1308-00	1	MANIFOLD, AIR
24	60-1309-00	1	MANIFOLD, AIR
25	60-1310-00	1	MANIFOLD, AIR
26	60-1311-00	1	MANIFOLD, AIR
27	60-1312-00	1	MANIFOLD, AIR
28	60-1313-00	1	MANIFOLD, AIR
29	60-1314-00	1	MANIFOLD, AIR
30	60-1315-00	1	MANIFOLD, AIR
31	60-1316-00	1	MANIFOLD, AIR
32	60-1317-00	1	MANIFOLD, AIR
33	60-1318-00	1	MANIFOLD, AIR
34	60-1319-00	1	MANIFOLD, AIR
35	60-1320-00	1	MANIFOLD, AIR
36	60-1321-00	1	MANIFOLD, AIR
37	60-1322-00	1	MANIFOLD, AIR
38	60-1323-00	1	MANIFOLD, AIR
39	60-1324-00	1	MANIFOLD, AIR
40	60-1325-00	1	MANIFOLD, AIR
41	60-1326-00	1	MANIFOLD, AIR
42	60-1327-00	1	MANIFOLD, AIR
43	60-1328-00	1	MANIFOLD, AIR
44	60-1329-00	1	MANIFOLD, AIR
45	60-1330-00	1	MANIFOLD, AIR
46	60-1331-00	1	MANIFOLD, AIR
47	60-1332-00	1	MANIFOLD, AIR
48	60-1333-00	1	MANIFOLD, AIR
49	60-1334-00	1	MANIFOLD, AIR
50	60-1335-00	1	MANIFOLD, AIR
51	60-1336-00	1	MANIFOLD, AIR

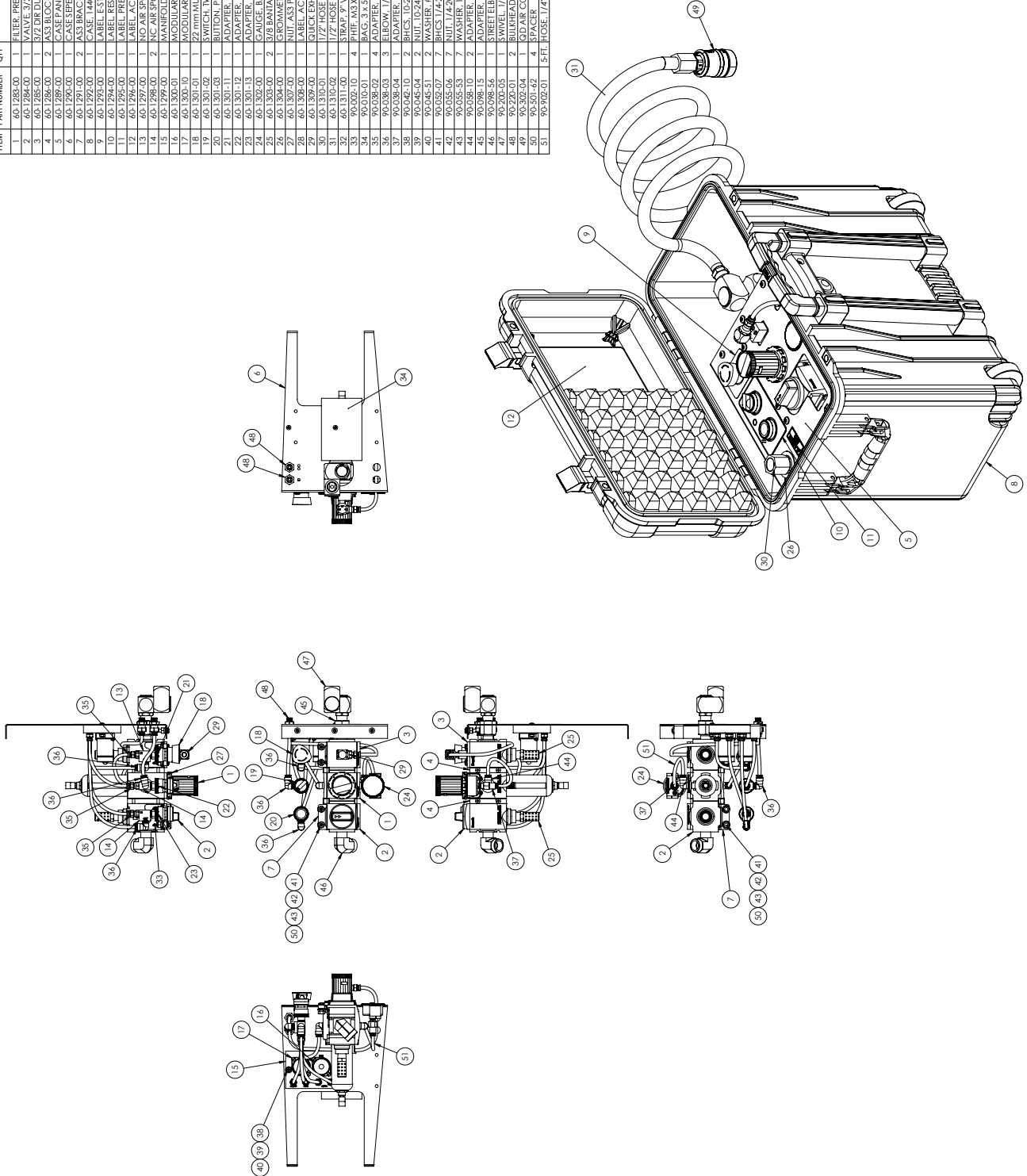

Remote Control Hand Pendant Assembly (60-373-00)

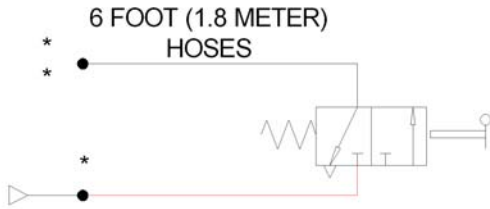

ITEM	PART NUMBER	QTY.	DESCRIPTION
1	56-206-00	1	LEVER, LOCKOFF
2	60-1280-00	1	HANDLE, SF REMOTE CONTROL
3	60-1281-00	1	VALVE, CARTRIDGE
4	60-1282-00	1	RING, SNAP .375 INTERNAL
5	90-038-02	2	ADAPTER, 1/8 NPTM X 1/4 PTC BRASS
6	90-046-51	1	PIN, 3/16 X 1 ROLL
7	90-902-02	6 FT	HOSE, 1/4" OD x 1/8" ID TWIN-LINE PU

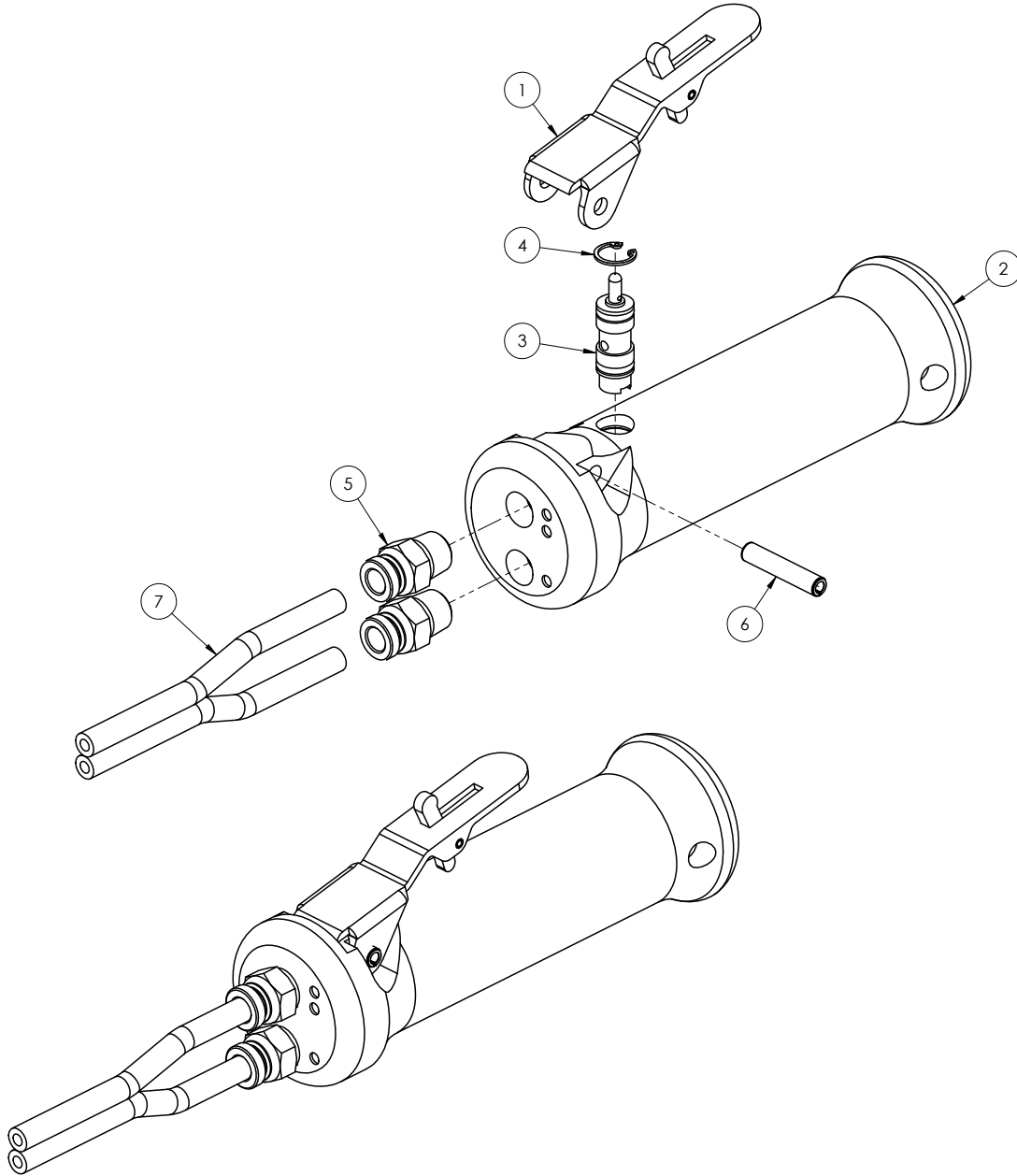

Air Control Module Schematic (60-375-00)

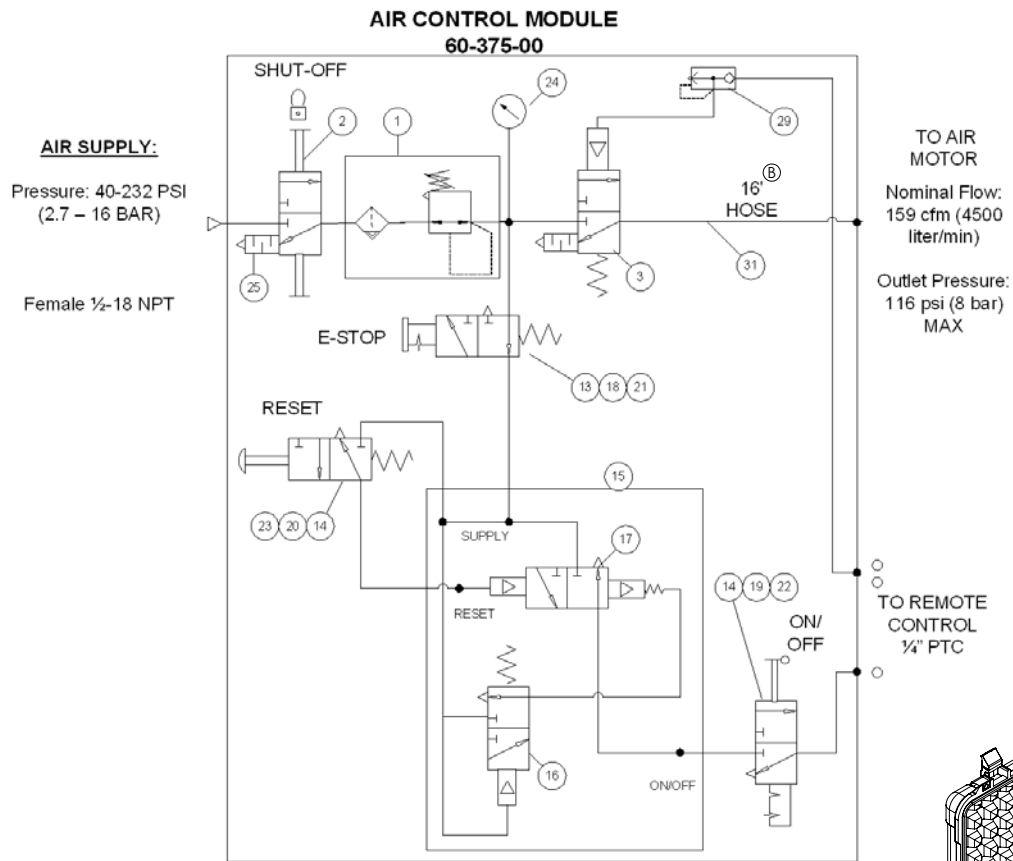

1. Ambient Temperature: 14° to 122° F (-10° to 50° C)
2. Refer to Manual or Label (Item #12) for sequence of operation
3. 90 psi (6.2 bar) required for optimal air motor performance

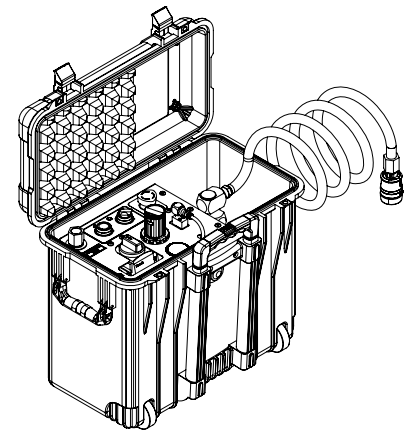

Chapter 9

Accessories and Spare Parts

ACCESSORIES

The following equipment accessories expand the operating capabilities of the low clearance split frame.

Table 1: Tool Slide Assemblies

Accessory	Description	Part No.
Standard Low Clearance Tool Slides (One setting only)	Parting slide	60-402-04
	Beveling slide	60-403-04
	Slide kit (parting slide, beveling slide, trip)	60-421-04
Extended Tool Slides	Parting slide	60-415-00
	Beveling slide	60-416-00
	Slide kit (parting slide, beveling slide, trip, extension blocks)	60-422-01
O.D. Tracking Slides (spring-loaded slides to track the surface of out-of-round pipe) for 610 through 1420 models	Parting slide	60-451-01
	Beveling slide	60-451-02
	Trip	60-451-03
Counterbore slide	Mounts to bevel slide for I.D. counterboring	60-405-UC
Bridge slide	Single point beveling and counterboring applications with LCSF models 612 through 1420	60-428-20

Table 2: Drive Motors and Components

Description	Part No.
1.5 HP right angle air drive	60-423-00
1.5 HP right angle air drive with ported exhaust collector	60-407-00
Heavy duty 2.5 HP right angle air motor	60-423-01
Hydraulic drive	60-424-00
Front drive pinion housing for 4"-20" LCSF	60-425-03
Air treatment module (for all air motors)	26-407-00

TOOLING

Table 3: LCSF Parting Tools







Part No.	Description	
43-711-00 43-711-00P	3/16" x 3-7/16" (4.76 x 87 mm) HSS parting tool	
43-711-01 43-711-01P	3/16" x 5" (4.76 x 127 mm) HSS parting tool	
60-711-00 60-711-00P	1/4" x 6" (6.35 x 152 mm) HSS parting tool	
60-716-00	4.3" (110 mm) carbide insert holder kit for 3/16" (4.76 mm) parting insert	
60-717-00	3/16" (4.76 mm) carbide insert	
60-714-00	4.3" (110 mm) carbide insert holder kit for 1/4" (6.35 mm) parting insert	
60-715-00	1/4" (6.35 mm) carbide insert	
60-SPT-11	3/16" wide special order	Design depends on application
60-SPT-12	1/4" wide special order	
60-SPT-13	1/2" wide special order	
<p>HSS = High Speed Steel 60-SPT-XX are made to customer specifications; call for quotation. Part numbers with "P" suffix are Premium Wachs tooling for high-alloy materials.</p>		

Table 4: LCSF Beveling and Counterbore Tools

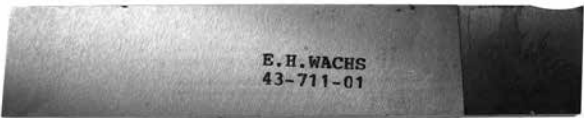







Description	Part No.	Application	
HSS Inside Bevel Tool			
30° x 3-1/8" (79 mm)	43-702-05	Short bevel tool for most materials. 30° - 1" (25 mm) and 37.5° - 3/4" (19 mm) maximum wall.	
37.5° x 3-1/8" (79 mm)	43-703-05		
30° x 5" (127 mm)	53-701-01 53-703-01P	Long bevel tool for most materials. 30° - 1" (25 mm) and 37.5° - 3/4" (19 mm) maximum wall.	
37.5° x 5" (127 mm)	53-701-00 53-703-00P		
HSS Outside Bevel Tool			
30° x 3-1/8" (79 mm)	43-707-05	Outside bevel tool for most materials. 30° - 1" (25 mm) and 37.5° - 3/4" (19 mm) maximum wall.	
30° x 5" (127 mm)	43-707-06		
37.5° x 3-1/8" (79 mm)	43-708-05		
37.5° x 5" (127 mm)	43-708-06		
HSS Double Bevel Tool			
30° x 3-1/8" (79 mm)	43-709-05	Double bevel tool for most materials. 3/4" (19 mm) maximum wall.	
30° x 5" (127 mm)	43-709-06		
37.5° x 3-1/8" (79 mm)	43-710-05		
37.5° x 5" (127 mm)	43-710-06		
HSS Compound Bevel Tool			
10° x 37.5° x 4" (102 mm) inside	43-712-01	Compound bevel tool for most materials. 1-1/4" (32 mm) maximum wall for both tools.	
10° x 37.5° x 4" (102 mm) outside	43-712-02		
10° x 37.5° x 5" (127 mm) inside	53-705-00		
10° x 30° x 5" (127 mm) inside	53-704-00		
HSS Counterbore Tool	60-700-04	4:1 taper; counterbores most materials. Requires 60-405-US universal counterbore slide or 60-420-XX bridge slide.	
HSS = High Speed Steel Part numbers with "P" suffix are Premium Wachs tooling for high-alloy materials.			
Special Application Tooling			

Table 4: LCSF Beveling and Counterbore Tools

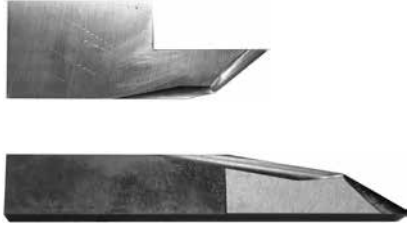

Description	Part No.	Application
3/4" wide x 3-1/8" HSS single angle bevel	60-SPT-02	Design depends on application
1-1/2" wide x 3-1/8" HSS single angle outside bevel	60-SPT-03	
1-1/2" wide x 3-1/8" HSS double bevel	60-SPT-05	
3/4" wide x 5" HSS single angle bevel	60-SPT-02	
1-1/2" wide x 5" HSS single angle outside bevel	60-SPT-04	
1-1/2" wide x 5" HSS double bevel	60-SPT-06	
60-SPT-XX are made to customer specifications; call for quotation.		

Table 5: LCSF Compound Angle Beveling Tools

Part No.	Description	
43-712-01	10° x 37.5° inside bevel	
53-704-00	10° x 30° inside bevel	
53-705-00	10° x 37.5° inside bevel	
43-712-02	10° x 37.5° outside bevel	
60-SPT-07	Custom HSS compound bevel tool	Design depends on application
60-SPT-08	Custom single-angle HSS J-Prep bevel tool	
60-SPT-09	Custom compound-angle HSS J-Prep bevel tool	

HSS = High Speed Steel
 60-SPT-XX are made to customer specifications; call for quotation.

Table 6: Single Point Tooling (Used with Bridge Slide)

Part No.	Description	
52-701-01 52-701-00P	HSS tool bit for single point facing and beveling. Standard 3/8" x 3/8" (9.53 x 9.53 mm).	
52-711-01	HSS 3/32" (2.38 mm) radius tool bit for J-prep	
52-711-02	HSS 1/8" (3.18 mm) radius tool bit for J-prep	
52-711-03	HSS 3/16" (4.76 mm) radius tool bit for J-prep	
60-707-00	Tool holder for HSS tool bits	

HSS = High Speed Steel

Part numbers with "P" suffix are Premium Wachs tooling for high-alloy materials.

HYDRAULIC POWER UNITS

The following Wachs hydraulic power units (HPUs) are designed to operate low clearance split frames and similar tools.

Table 7: Hydraulic Power Units for LCSF

Power Unit	Part No.
HCM-1G gas powered, 8 gpm @ 1500 psi (30 l/min @ 103 bar)	14-000-01
HCM-2E2 electric powered, 8 gpm @ 1500 psi (30 l/min @ 103 bar)	14-000-06
HCM-2E4 electric powered, 8 gpm @ 1500 psi (30 l/min @ 103 bar)	14-000-07
HCM-2G gas powered, 10 gpm @ 1500 psi (38 l/min @ 103 bar)	14-000-08
HCM-3D diesel powered, 10 gpm @ 1500 psi (38 l/min @ 103 bar)	14-000-09
HCM-3G gas powered, 14 gpm @ 1500 psi (53 l/min @ 103 bar)	14-000-25
HCM-4D diesel powered, 14 gpm @ 1500 psi (53 l/min @ 103 bar)	14-000-26
HPU-15 electric powered, 0-15 gpm @ 1500 psi (0-57 l/min @ 103 bar)	14-000-20
HSM-5D diesel powered (skid mount), 14 gpm @ 1500 psi (53 l/min @ 103 bar)	14-000-31
HTM-5D diesel powered (trailer mount), 14 gpm @ 1500 psi (53 l/min @ 103 bar)	14-000-32
Tandem Pump Offshore diesel powered, 15 gpm @ 2000 psi (57 l/min @ 140 bar)	14-000-12

RECOMMENDED SPARES

Spare parts and fastener kits are available for the LCSF. Select the kit(s) appropriate for your LCSF model. Separate kits are provided for the base LCSF machine and for the tool slides.

(Note that the spare parts kits include fastener kits. Fastener kits can also be purchased separately.)

Table 8: LCSF Spare Parts Kits

Kit No.	Description	Part Description	Part No.	Qty
60-551-01	Spare Parts Kit for LCSF, 4" through 20" (models 204 through 1420)	Bearing, Guide Wheel	37-005-00	5
		Lock Pin Chain	46-067-00	2
		Eccentric Bearing Shaft	60-105-02	3
		SHCS, 5/16-18 x 1-5/8 Captivated	60-122-00	2
		Rear Pinion Bearing	60-125-00	1
		Front Pinion Bearing	60-126-00	1
		Frame Bearing Spacer	60-128-01	5
		Pin, Frame Locking	60-129-00	2
		Plug, Bearing Cap	60-130-00	5
		SHCS, 1/2-13 x 2-1/2 Captivated	60-207-00	2
		Kit, LCSF 4"-20" Fasteners	60-550-01	1
60-551-03	Spare Parts Kit for Low-Clearance Slide Set (60-421-04)	Feed Nut	60-116-00	2
		Feed Screw	60-118-04	1
		Trip Pin	60-338-00	2
		Kit, LC Slide Fasteners	60-550-03	1
		Spring Plunger, 1/4-20 x 1/2	90-059-08	1
60-551-04	Spare Parts Kit for Extended Slide Set (60-422-01)	Feed Screw	60-195-00	1
		Alignment Pin	60-196-00	2
		Feed Nut	60-229-00	2
		Shim Kit	60-232-00	1
		Trip Pin	60-338-00	2
		Kit, LC Slide Fasteners	60-550-03	1
		Spring Plunger, 1/4-20 x 1/2	90-059-08	1
60-551-07	Spare Parts Kit for Universal Counterbore Slide	Feed Screw	60-147-00	1
		Bushing LC1-12	60-150-00	1
		Bushing LC1-3	60-157-00	1
		Rev. 1 to Rev 2 Upgrade Kit	60-370-00	1
		Kit, Universal Counterbore Slide Fasteners	60-550-07	1

Chapter 10

Ordering Information

To place an order, request service, or get more detailed information on any E.H. Wachs products, call us at one of the following numbers:

U.S. 800-323-8185
International: 847-537-8800

You can also visit our Web site at:

www.ehwachs.com

ORDERING REPLACEMENT PARTS

When ordering parts, refer to the drawings and parts lists in Chapter 8. Please provide the part description and part number for all parts you are ordering.

REPAIR INFORMATION

Please call us for an authorization number before returning any equipment for repair or factory service. We will advise you of shipping and handling. When you send the equipment, please include the following information:

- Your name/company name
- Your address
- Your phone number
- A description of the problem or the work to be done.

Before we perform any repair, we will estimate the work and inform you of the cost and the time to complete it.

WARRANTY INFORMATION

Enclosed with the manual is a warranty card. Please fill out the registration card and return to E.H. Wachs. Retain the owner's registration record and warranty card for your information.

RETURN GOODS ADDRESS

Return equipment for repair to the following address.

E.H. Wachs
600 Knightsbridge Parkway
Lincolnshire, Illinois 60069 USA