



# Operator's Manual

## Serial Number Range

**GS™-1530/32**

from GS30P-200101

**GS™-1930/32**

from GS32P-200101

**GS™-1932 XH**

from GS46P-200101

**GS™-2032**

from GS30D-40101

**GS™-2632**

from GS32D-10101

**GS™-3232**

from GS46D-20101

**GS™-2046**

**GS™-2646**

**GS™-2646 XH**

**GS™-3246**

**GS™-3246 XH**

**GS™-4046**

CE

with  
Maintenance  
Information

Original Instructions  
Eleventh Edition  
Second Printing  
Part No. 1307633GT

**Manufacturer:**

Terex South Dakota, Inc.  
500 Oakwood Road  
Watertown, SD 57201, USA

Terex (Changzhou) Machinery Co., Ltd.  
No 139, Hanjiang Road  
Xinbei District  
Changzhou City  
Jiangsu Province  
China

**Authorized representative:**

Genie Industries B. V.  
Boekerman 5  
4751 XK OUD GASTEL  
The Netherlands

**Contents**

Introduction .....	1
Symbol and Hazard Pictorials Definitions .....	6
General Safety .....	9
Personal Safety .....	18
Work Area Safety .....	19
Legend .....	27
Controls .....	30
Inspections .....	34
Operating Instructions .....	54
Transport and Lifting Instructions .....	71
Maintenance .....	76
Specifications .....	78

Copyright © 1997 Terex Corporation

Eleventh Edition: Second Printing, November 2020

Genie is a registered trademark of Terex South Dakota, Inc. in the U.S.A. and many other countries. "GS" is a trademark of Terex South Dakota, Inc.

 Complies with EC Directive 2006/42/EC  
See EC Declaration of Conformity



# Introduction

## About this manual

Genie appreciates your choice of our machine for your application. Our number one priority is user safety, which is best achieved by our joint efforts. This book is an operation and daily maintenance manual for the user or operator of a Genie machine.

This manual should be considered a permanent part of your machine and should remain with the machine at all times. If you have any questions, contact Genie.

## Product Identification

The machine serial number is located on the serial label.

Serial label located on chassis

Serial number stamped on chassis

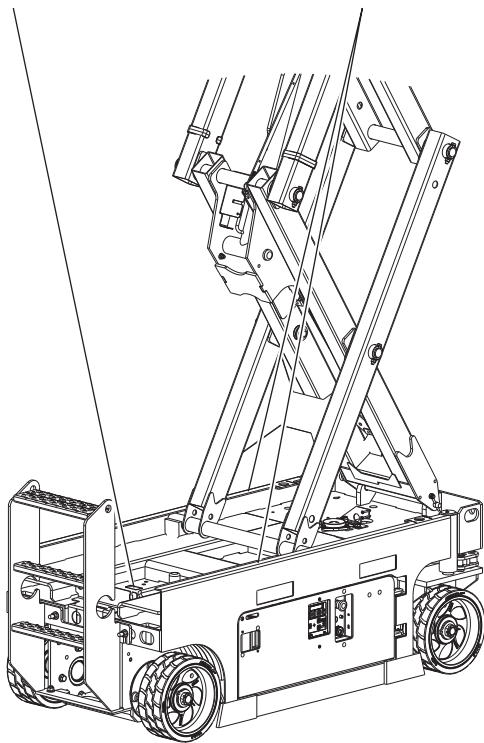

## Intended Use and Familiarization Guide

The intended use of this machine is to lift personnel, including tools, and materials to an aerial work site. Before operating the machine, it's the operator's responsibility to read and understand this familiarization guide.

- Each person must be trained to operate a Mobile Elevating Work Platform (MEWP).
- Familiarization with the MEWP must be given to each person who is authorized, competent and trained.
- Only trained and authorized personnel should be permitted to operate the machine.
- The operator is responsible to read, understand, and obey the manufacturer's instructions and safety rules provided in the Operator's Manual.
- The Operator's Manual is located in the manual storage container, at the platform.
- For specific product applications, see **Contacting The Manufacturer**.

# Introduction

## Platform controls symbology and related machine movement:



Lift function enable button



Drive function enable button



Outrigger function button



Platform up/down (when lift function selected)



Drive forward/reverse (when drive function selected)



Steer right/left (when drive function selected)



Area of operation, indoor use button



Area of operation, outdoor use button

## Ground controls symbology and related machine movement:



Lift function enable button



Platform up/down button

## Sequential functions and movement:

- Drive and steer.

## Interlocked functions:

- Elevated drive speed.
- Elevated drive in an off-level condition.
- All platform and ground controls.

## Limitations of use:

- The intended use of this machine is to lift personnel, including tools, and materials to an aerial work site.
- Do not elevate the platform unless the machine is on firm level ground.



---

# Introduction

## Bulletin Distribution and Compliance

Safety of product users is of paramount importance to Genie. Various bulletins are used by Genie to communicate important safety and product information to dealers and machine owners.

The information contained in the bulletins is tied to specific machines using the machine model and serial number.

Distribution of bulletins is based on the most current owner on record along with their associated dealer, so it is important to register your machine and keep your contact information up to date.

To ensure safety of personnel and the reliable continued operation of your machine, be sure to comply with the action indicated in a respective bulletin.

To view any open bulletins for your machine, visit us on the web at [www.genielift.com](http://www.genielift.com).

## Contacting the Manufacturer

At times it may be necessary to contact Genie. When you do, be ready to supply the model number and serial number of your machine, along with your name and contact information. At minimum, Genie should be contacted for:

Accident reporting

Questions regarding product applications and safety

Standards and regulatory compliance information

Current owner updates, such as changes in machine ownership or changes in your contact information. See Transfer of Ownership, below.

## Transfer of Machine Ownership

Taking a few minutes to update owner information will ensure that you receive important safety, maintenance and operating information that applies to your machine.

Please register your machine by visiting us on the web at [www.genielift.com](http://www.genielift.com) or by calling us toll free at 1-800-536-1800.

---

# Introduction



---

## Danger

Failure to obey the instructions and safety rules in this manual will result in death or serious injury.

---

## Do Not Operate Unless:

- You learn and practice the principles of safe machine operation contained in this operator's manual.
  - 1 Avoid hazardous situations.**
    - Know and understand the safety rules before going on to the next section.**
    - 2 Always perform a pre-operation inspection.
    - 3 Always perform function tests prior to use.
    - 4 Inspect the workplace.
    - 5 Only use the machine as it was intended.
- You read, understand and obey the manufacturer's instructions and safety rules—safety and operator's manuals and machine decals.
- You read, understand and obey employer's safety rules and worksite regulations.
- You read, understand and obey all applicable governmental regulations.
- You are properly trained to safely operate the machine.

## Safety Sign Maintenance

Replace any missing or damaged safety signs. Keep operator safety in mind at all times. Use mild soap and water to clean safety signs. Do not use solvent-based cleaners because they may damage the safety sign material.

# Introduction

## Hazard Classification

Decals on this machine use symbols, color coding, and signal words to identify the following:



Safety alert symbol—used to alert you to potential personal injury hazards. Obey all safety messages that follow this symbol to avoid possible injury or death.

**⚠ DANGER**

Indicates a hazardous situation which, if not avoided, will result in death or serious injury.

**⚠ WARNING**

Indicates a hazardous situation which, if not avoided, could result in death or serious injury.















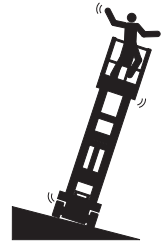
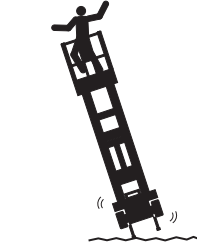

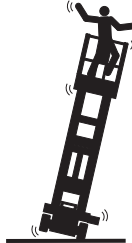
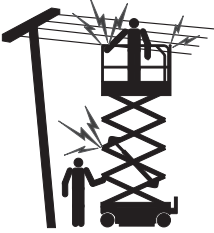
**⚠ CAUTION**

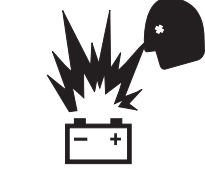
Indicates a hazardous situation which, if not avoided, could result in minor or moderate injury.

**NOTICE**

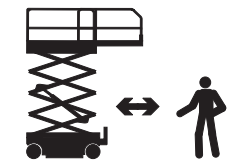
Indicates a property damage message.







# Symbol and Hazard Pictorials Definitions

				
Read the operator's manual	Read the service manual	Crush hazard	Crush hazard	Collision hazard
				
Tip-over hazard	Tip-over hazard	Tip-over hazard	Tip-over hazard	Electrocution hazard
				
Electrocution hazard	Explosion hazard	Fire hazard	Burn hazard	Skin injection hazard
				
Engage safety arm	Keep away from moving parts	Keep clear of outriggers and tires	Move machine to level ground	Close chassis tray

## Symbol and Hazard Pictorials Definitions

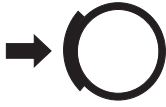
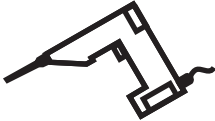
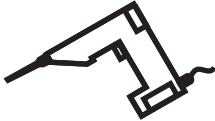
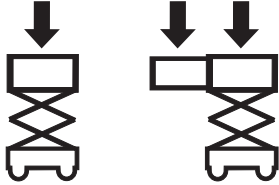
 <p>Lower the platform.</p>	 <p>Do not set up where it cannot be leveled with outriggers</p>	 <p>Maintain required clearance</p>	 <p>Access by trained and authorized personnel only</p>	 <p>Use a piece of cardboard or paper to search for leaks</p>
 <p>Batteries used as counterweights</p>	 <p>Chock the wheels</p>	 <p>No smoking</p>	 <p>Grounded AC 3-wire only</p>	 <p>Replace damaged wires and cords</p>
 <p>Wheel load</p>	 <p>Lifting &amp; tie down instructions</p>	 <p>Lifting point</p>	 <p>Lanyard anchorage points</p>	 <p>Wind speed</p>

# Symbol and Hazard Pictorials Definitions

 <p>Tiedown</p>	 <p>Release brakes</p>	 <p>Engage brake</p>	 <p>Pressure rating for air line to platform</p>	 <p>Voltage rating for power to platform</p>
 <p>Maximum capacity</p>		 <p>Indoor</p>	 <p>Outdoor</p>	 <p>Manual force</p>
 <p>Platform overloaded</p>				

# General Safety

## GS-1530, GS-1532, GS-1930, GS-1932, GS-1932 XH

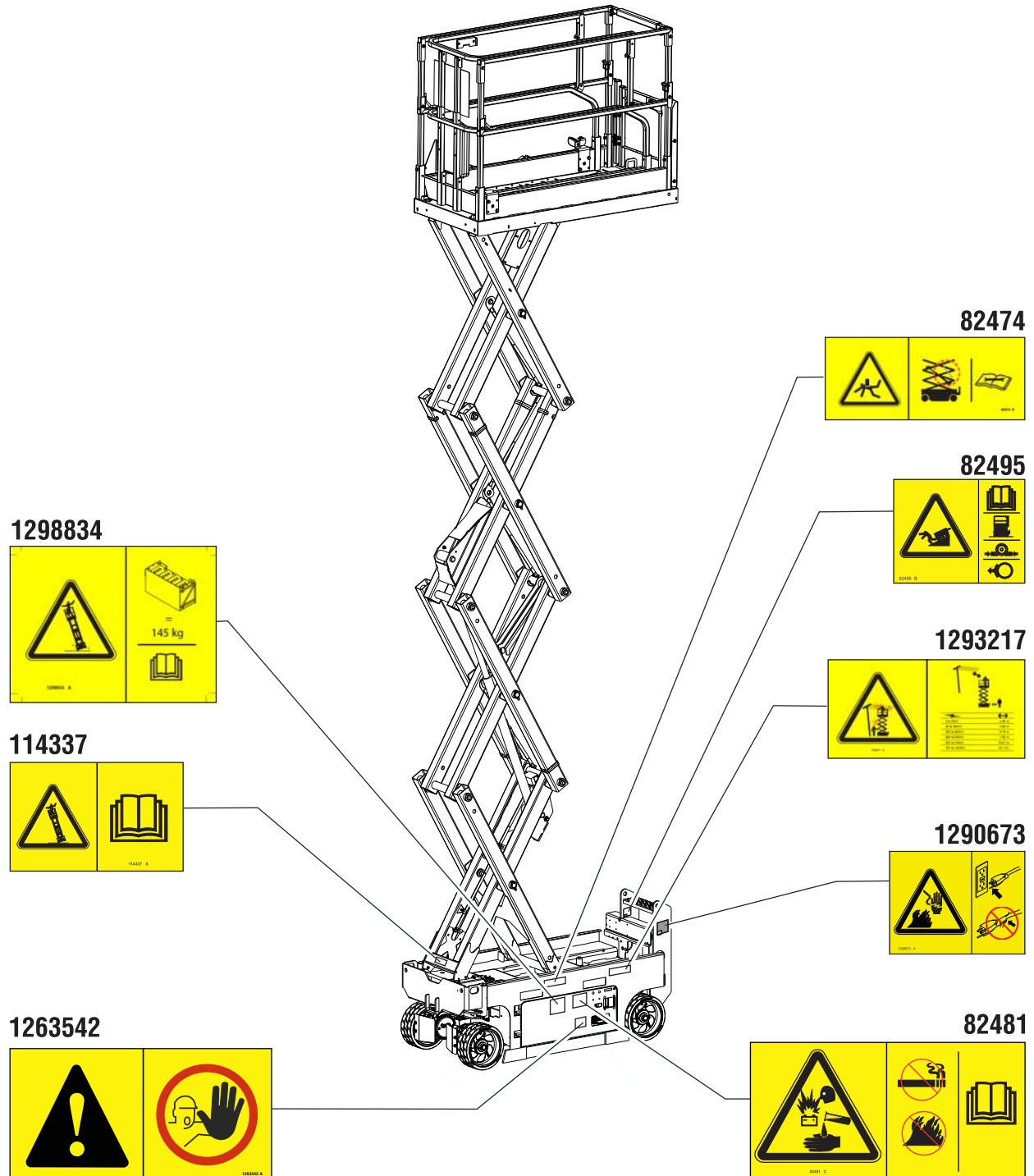

# General Safety

## GS-1530, GS-1532, GS-1930, GS-1932, GS-1932 XH

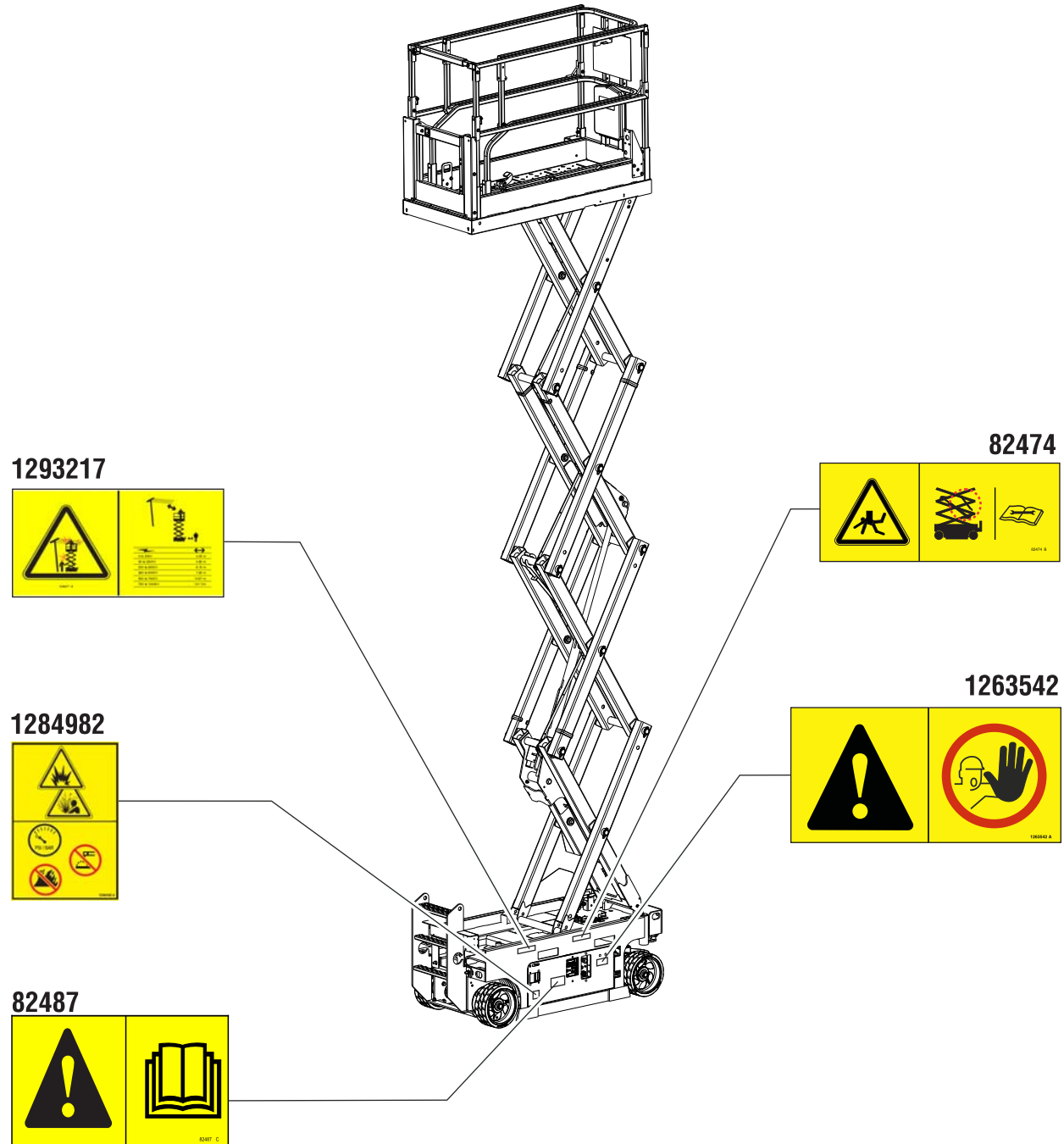



# General Safety

## GS-1530, GS-1532, GS-1930, GS-1932, GS-1932 XH

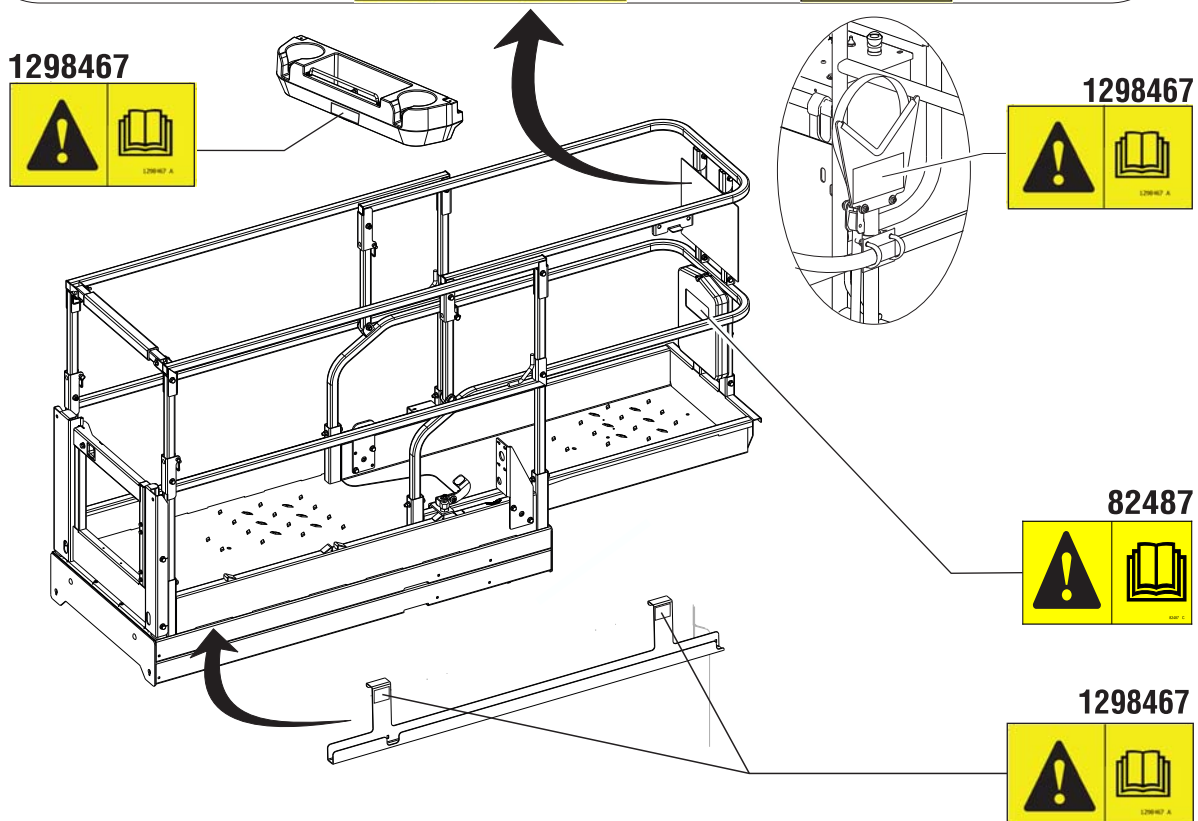
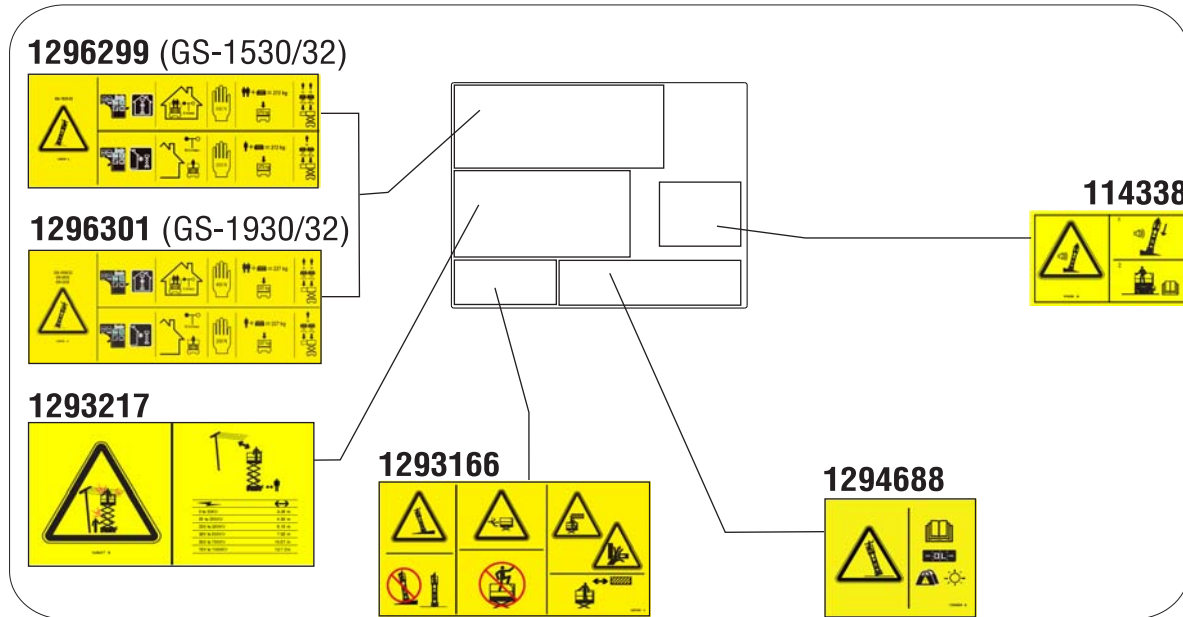

# General Safety

## GS-2032, GS-2632, GS-3232

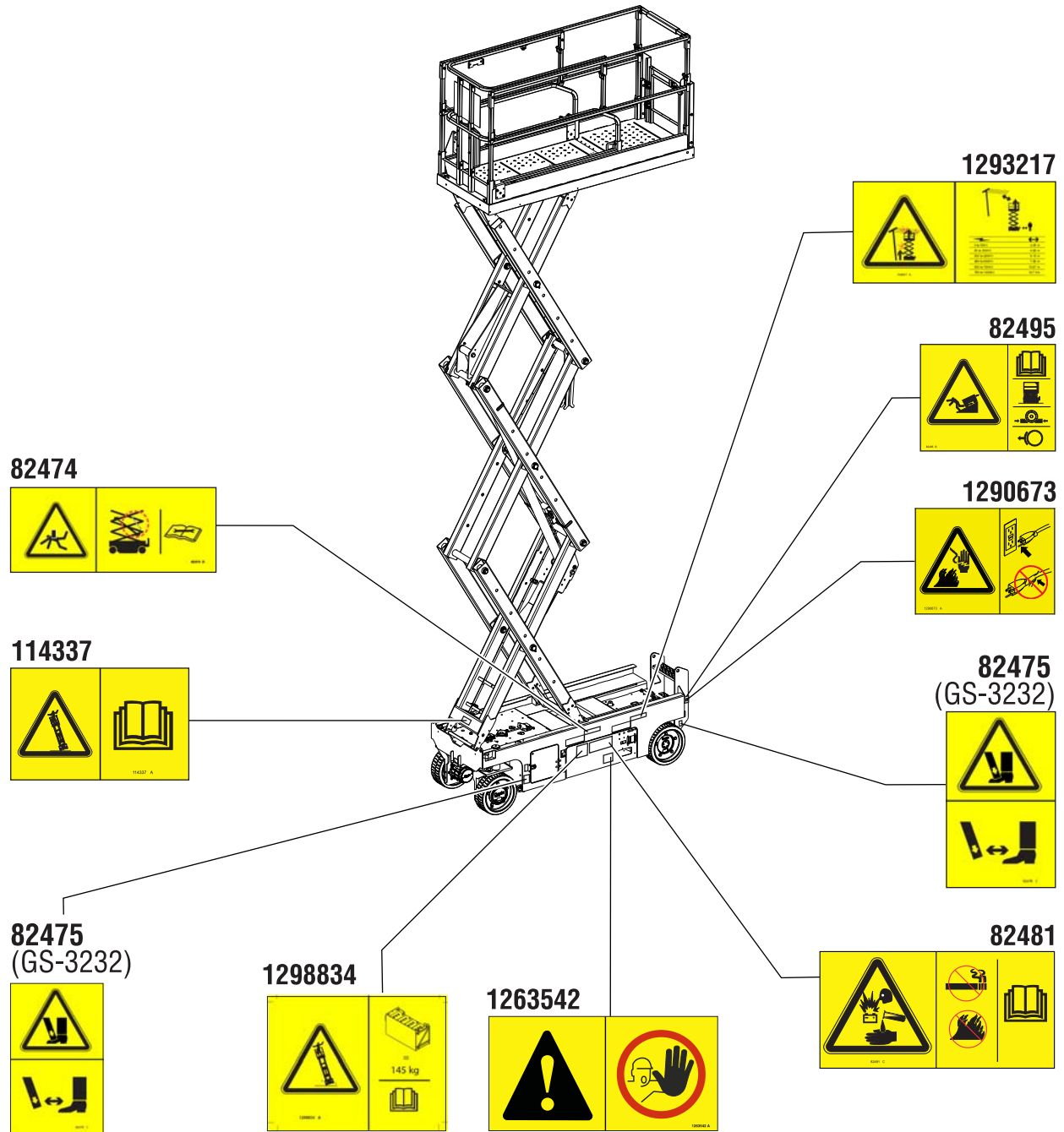

# General Safety

## GS-2032, GS-2632, GS-3232

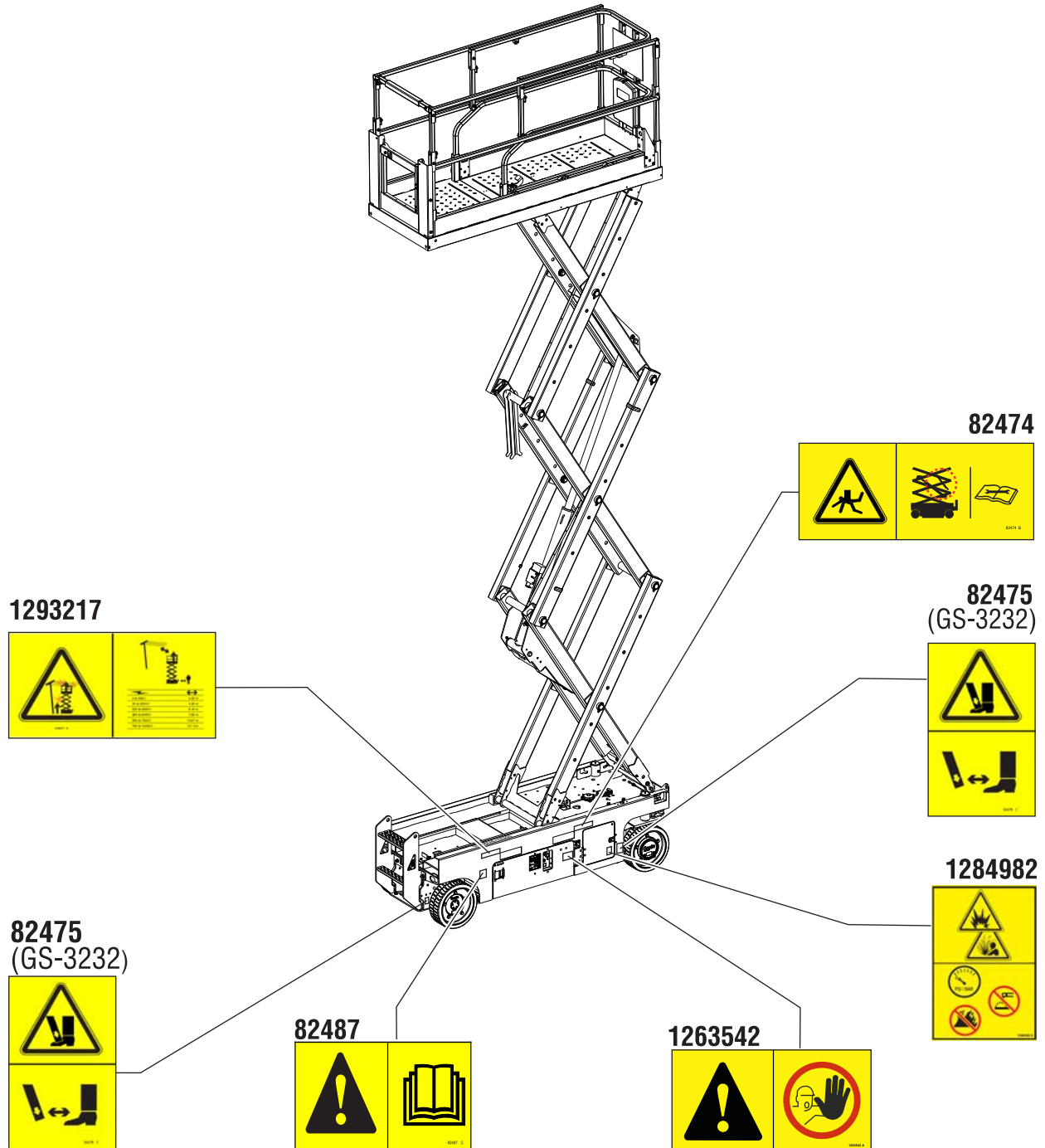

# General Safety

## GS-2032, GS-2632, GS-3232

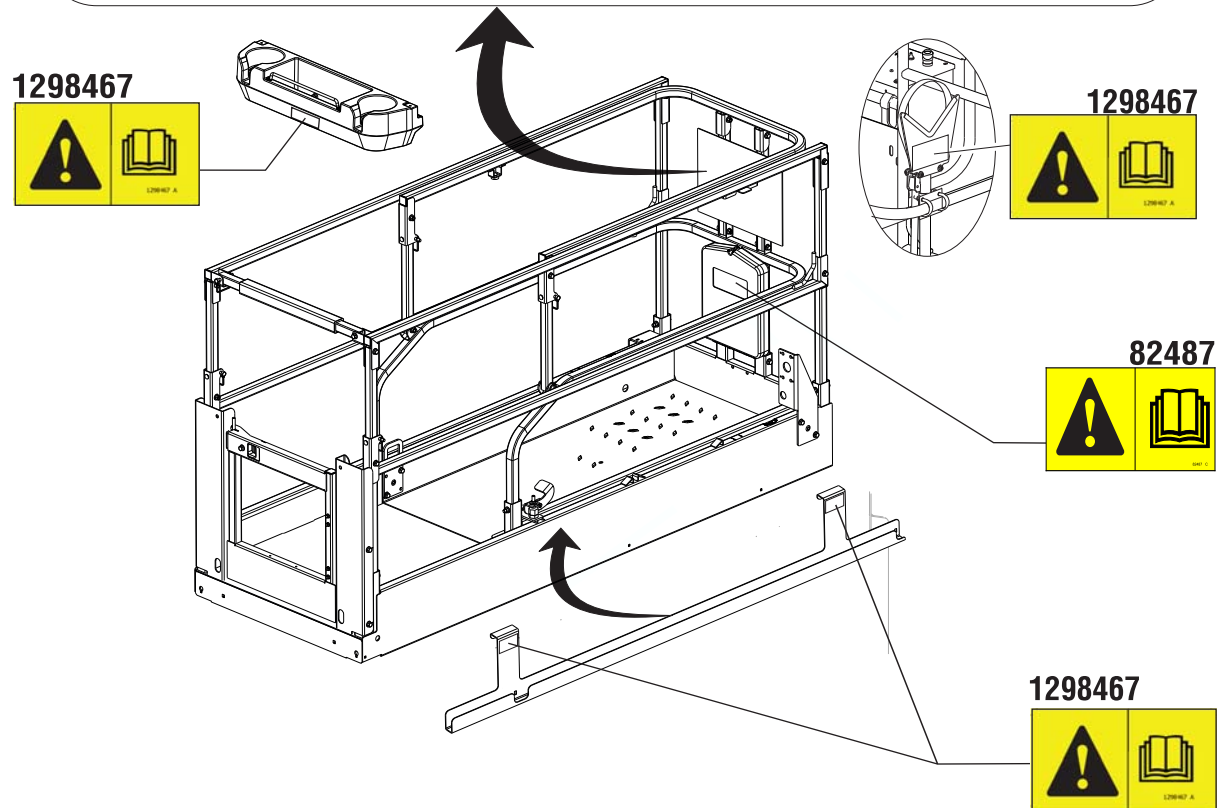
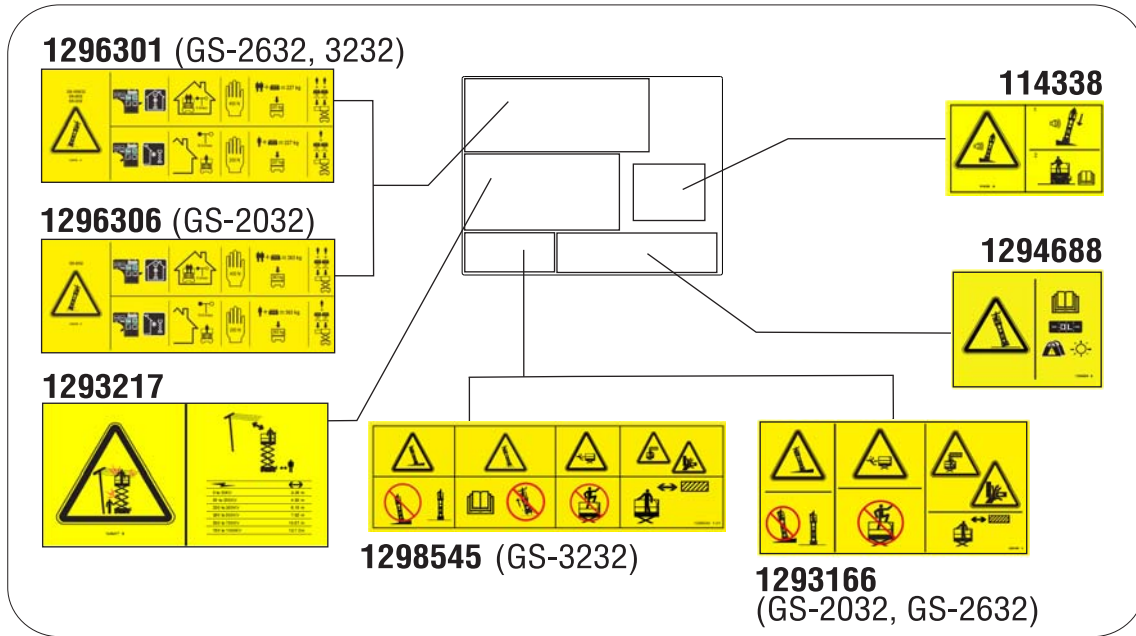

# General Safety

## GS-2046, GS-2646, GS-2646XH, GS-3246, GS-3246 XH, GS-4046

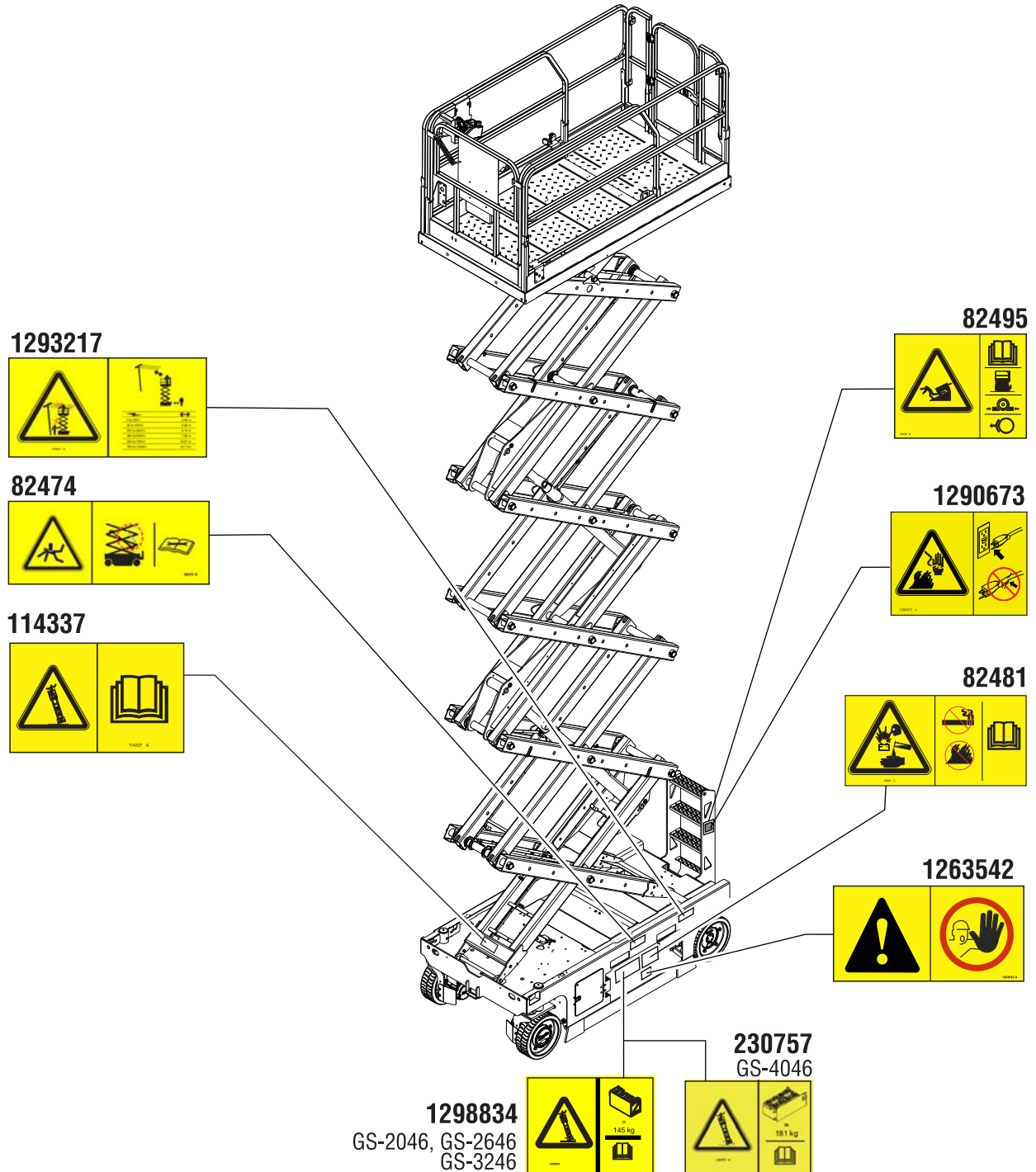

# General Safety

GS-2046, GS-2646, GS-2646XH, GS-3246, GS-3246 XH, GS-4046

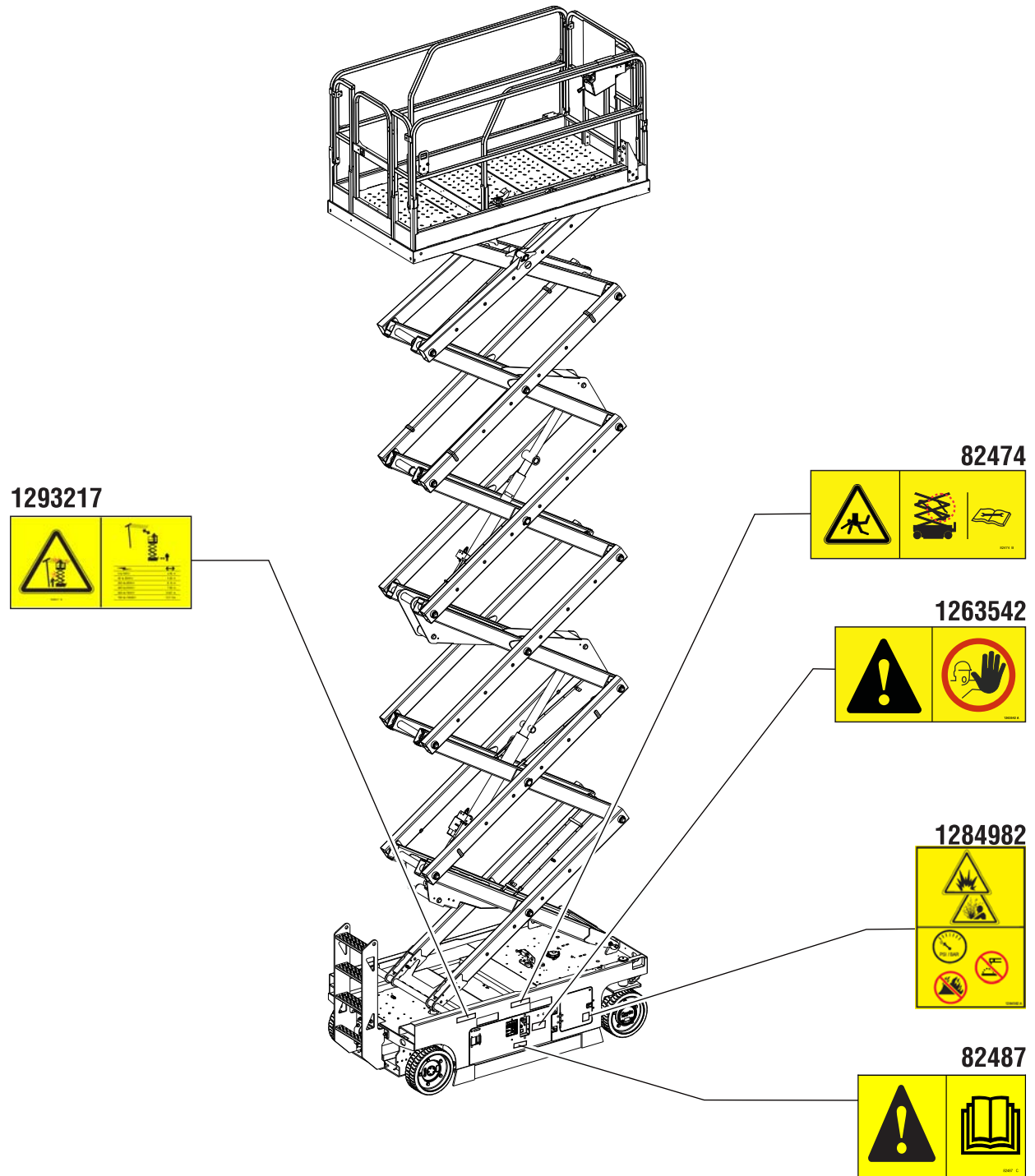



# General Safety

## GS-2046, GS-2646, GS-2646XH, GS-3246, GS-3246 XH, GS-4046

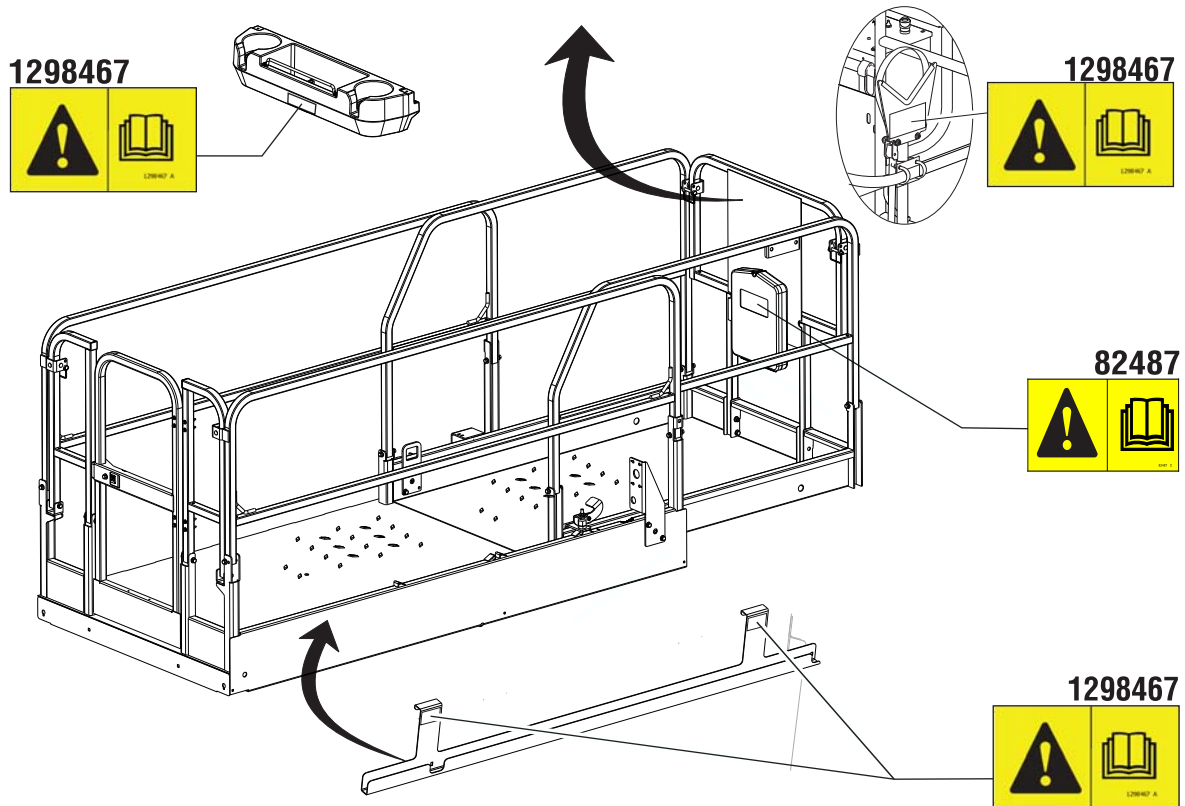
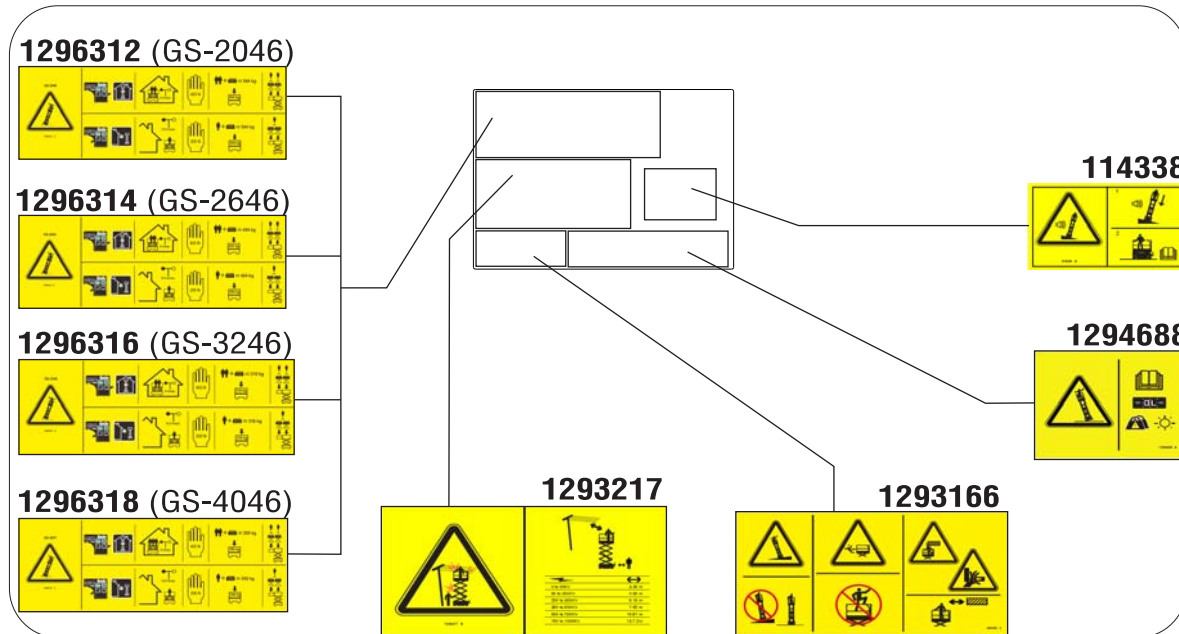

---

# Personal Safety

## Personal Fall Protection

Personal fall protection equipment (PFPE) is not required when operating this machine. If PFPE is required by job site or employer rules, the following shall apply:

All PFPE must comply with applicable governmental regulations and must be inspected and used in accordance with the manufacturer's instructions.



# Work Area Safety

## ⚠ Electrocuting Hazards

This machine is not electrically insulated and will not provide protection from contact with or proximity to electrical current.



Obey all local and governmental regulations regarding required clearance from electrical power lines. At a minimum, the required clearance contained in the chart below must be followed.

Line Voltage	Required Clearance	
0 to 50KV	10 ft	3.05 m
50 to 200KV	15 ft	4.60 m
200 to 350KV	20 ft	6.10 m
350 to 500KV	25 ft	7.62 m
500 to 750KV	35 ft	10.67 m
750 to 1000KV	45 ft	13.72 m

Allow for platform movement, electrical line sway or sag, and beware of strong or gusty winds.



Keep away from the machine if it contacts energized power lines. Personnel on the ground or in the platform must not touch or operate the machine until energized power lines are shut off.

Do not operate the machine during lightning or storms.

Do not use the machine as a ground for welding.

## ⚠ Tip-over Hazards

Occupants, equipment and materials shall not exceed the maximum platform capacity or the maximum platform capacity of the platform extension.

### Maximum capacity

Model	Platform extended			
	Platform retracted	Platform only	Extension only	Maximum occupants
GS-1530	600 lbs	350 lbs	250 lbs	Indoor – 2
	272 kg	159 kg	113 kg	Outdoor – 1
GS-1532	600 lbs	350 lbs	250 lbs	Indoor – 2
	272 kg	159 kg	113 kg	Outdoor – 1
GS-1930	500 lbs	250 lbs	250 lbs	Indoor – 2
	227 kg	113 kg	113 kg	Outdoor – 1
GS-1932, GS-1932 XH	500 lbs	250 lbs	250 lbs	Indoor – 2
	227 kg	113 kg	113 kg	Outdoor – 1
GS-2032	800 lbs	550 lbs	250 lbs	Indoor – 2
	363 kg	250 kg	113 kg	Outdoor – 1
GS-2632	500 lbs	250 lbs	250 lbs	Indoor – 2
	227 kg	113 kg	113 kg	Outdoor – 1
GS-3232	500 lbs	250 lbs	250 lbs	Indoor – 2
	227 kg	113 kg	113 kg	Outdoor – 1
GS-2046	1200 lbs	950 lbs	250 lbs	Indoor – 2
	544 kg	431 kg	113 kg	Outdoor – 1
GS-2646, GS-2646 XH	1000 lbs	750 lbs	250 lbs	Indoor – 2
	454 kg	340 kg	113 kg	Outdoor – 1
GS-3246	700 lbs	450 lbs	250 lbs	Indoor – 2
	318 kg	204 kg	113 kg	Outdoor – 1
GS-3246 XH	700 lbs	450 lbs	250 lbs	Indoor – 2
	318 kg	204 kg	113 kg	Outdoor – 1
GS-4046	770 lbs	520 lbs	250 lbs	Indoor – 3
	350 kg	236 kg	113 kg	Outdoor – 1

Platform retracted



Platform extended



Extension only

Platform only

## Work Area Safety

The weight of options and accessories, such as panel carriers, will reduce the rated platform capacity and must be subtracted from the platform capacity. See the decals with the options and accessories.

If using accessories, read, understand and obey the decals, instructions and manuals with the accessory.



Do not raise the platform unless the machine is on a firm, level surface.



Do not depend on the tilt alarm as a level indicator. The tilt alarm sounds on the chassis only when the machine is on a severe slope.

If the tilt alarm sounds:

Lower the platform. Move the machine to a firm, level surface. If the tilt alarm sounds when the platform is raised, use extreme caution to lower the platform.

Do not drive over 0.5 mph / 0.8 km/h with the platform raised.

Follow ratings for allowable side force and number of occupants shown below.

Do not raise the platform when wind speeds may exceed 28 mph / 12.5 m/s. If wind speeds exceed 28 mph / 12.5 m/s when the platform is raised, lower the platform and do not continue to operate the machine.

Outdoor use: Do not operate the machine outdoors with the indoor use button selected.

## Work Area Safety



Do not operate the machine in strong or gusty winds. Do not increase the surface area of the platform or the load. Increasing the area exposed to the wind will decrease machine stability.



Do not push off or pull toward any object outside of the platform.



Use extreme care and slow speeds while driving the machine in the stowed position across uneven terrain, debris, unstable or slippery surfaces and near holes and drop-offs.

Do not drive the machine on or near uneven terrain, unstable surfaces or other hazardous conditions with the platform raised.

Do not use the machine as a crane.

Do not push the machine or other objects with the platform.

Do not contact adjacent structures with the platform.

Do not tie the platform to adjacent structures.

Do not place loads outside the platform perimeter.

Do not operate the machine with the chassis trays open.

Model	Maximum allowable side force	Maximum occupants
<b>GS-1530</b>	Indoor – 90 lbs/400N	Indoor – 2
	Outdoor – 45 lbs/200 N	Outdoor – 1
<b>GS-1532</b>	Indoor – 90 lbs/400N	Indoor – 2
	Outdoor – 45 lbs/200 N	Outdoor – 1
<b>GS-1930</b>	Indoor – 90 lbs/400N	Indoor – 2
	Outdoor – 45 lbs/200 N	Outdoor – 1
<b>GS-1932, GS-1932 XH</b>	Indoor – 90 lbs/400N	Indoor – 2
	Outdoor – 45 lbs/200 N	Outdoor – 1
<b>GS-2032</b>	Indoor – 90 lbs/400N	Indoor – 2
	Outdoor – 45 lbs/200 N	Outdoor – 1
<b>GS-2632</b>	Indoor – 90 lbs/400N	Indoor – 2
	Outdoor – 45 lbs/200 N	Outdoor – 1
<b>GS-3232</b>	Indoor – 90 lbs/400N	Indoor – 2
	Outdoor – 45 lbs/200 N	Outdoor – 1
<b>GS-2046</b>	Indoor – 90 lbs/400N	Indoor – 2
	Outdoor – 45 lbs/200 N	Outdoor – 1
<b>GS-2646, GS-2646 XH</b>	Indoor – 90 lbs/400N	Indoor – 2
	Outdoor – 45 lbs/200 N	Outdoor – 1
<b>GS-3246, GS-3246 XH</b>	Indoor – 90 lbs/400N	Indoor – 2
	Outdoor – 45 lbs/200 N	Outdoor – 1
<b>GS-4046</b>	Indoor – 90 lbs/400N	Indoor – 3
	Outdoor – 45 lbs/200 N	Outdoor – 1

## Work Area Safety

Do not alter or disable the limit switches.

Do not alter or disable machine components that in any way affect safety and stability.

Do not replace items critical to machine stability with items of different weight or specification.

Do not use batteries that weigh less than the original equipment. Batteries are used as counterweight and are critical to machine stability. Each battery must weigh a minimum of 62 lbs/28.1 kg. Battery tray including batteries must weigh a minimum of 319 lbs/145 kg.

For GS-4046 units, each battery must weigh a minimum of 82 lbs/37 kg. The battery tray including batteries must weigh a minimum of 399 lbs/181 kg.

Do not modify or alter a mobile elevated work platform without prior written permission from the manufacturer. Mounting attachments for holding tools or other materials onto the platform, toeboards, or guard rail system can increase the weight in the platform and the surface area of the platform or the load.



Do not place or attach fixed or overhanging loads to any part of this machine.



Do not place ladders or scaffolds in the platform or against any part of this machine.

Do not transport tools and materials unless they are evenly distributed and can be safely handled by person(s) in the platform.

Do not use the machine on a moving or mobile surface or vehicle.

Be sure all tires are in good condition, castle nuts are properly tightened and cotter pins are properly installed.

### If equipped with outriggers

Do not set the machine up where it cannot be leveled using only the outriggers.

Do not adjust the outriggers while the platform is raised.

Do not drive while the outriggers are lowered.

## Work Area Safety

### ▲ Crushing Hazard

Keep hands and limbs out of scissors.

Keep hands clear when folding rails.

Do not work under the platform or in the scissor links without the safety arm in place.

Use common sense and planning when operating the machine with the controller from the ground. Maintain safe distances between the operator, the machine and fixed objects.

### ▲ Operation on Slopes Hazards

Do not drive the machine on a slope that exceeds the slope and side slope rating of the machine. Slope rating applies to machines in the stowed position.

Model	Maximum slope rating, stowed position	Maximum side slope rating, stowed position
<b>GS-1530</b>	30% (16.7°)	30% (16.7°)
<b>GS-1930</b>	25% (14°)	25% (14°)
<b>GS-1932, GS-1932 XH</b>	25% (14°)	25% (14°)
<b>GS-2032</b>	30% (16.7°)	30% (16.7°)
<b>GS-2632</b>	25% (14°)	25% (14°)
<b>GS-3232</b>	25% (14°)	25% (14°)
<b>GS-2046</b>	30% (16.7°)	30% (16.7°)
<b>GS-2646, GS-2646 XH</b>	30% (16.7°)	30% (16.7°)
<b>GS-3246, GS-3246 XH</b>	25% (14°)	25% (14°)
<b>GS-4046</b>	25% (14°)	25% (14°)

Note: Slope rating is subject to ground conditions with one person in the platform and adequate traction. Additional platform weight may reduce slope rating. See Driving on a Slope in the Operating Instructions section.

## Work Area Safety

### ▲ Fall Hazards

The guard rail system provides fall protection. If occupant(s) of the platform are required to wear personal fall protection equipment (PFPE) due to job site or employer rules, PFPE and its use shall be in accordance with the PFPE manufacturer's instructions and applicable governmental requirements. Use approved lanyard attachment point provided.



Do not sit, stand, or climb on the platform guard rails. Maintain a firm footing on the platform floor at all times.



Do not climb down from the platform when raised.

Keep the platform floor clear of debris.

Close the entry gate before operating.

Do not operate the machine unless the guard rails are properly installed and the entry is secured for operation.

Do not enter or exit the platform unless the machine is in the stowed position.

### ▲ Collision Hazards

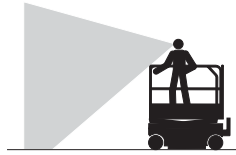

Be aware of limited sight distance and blind spots when driving or operating.

Be aware of extended platform position when moving the machine.

The machine must be on a level surface and wheels chocked or secured before releasing the brakes.

Operators must comply with employer, job site, and governmental rules regarding use of personal protective equipment.



Check the work area for overhead obstructions or other possible hazards.



Be aware of crushing hazards when grasping the platform guard rail.

Observe and use color-coded direction arrows on the platform controls and the platform decal plate for drive and steer functions.

## Work Area Safety



Do not lower the platform unless the area below is clear of personnel and obstructions.



Limit travel speed according to the condition of the ground surface, congestion, slope, location of personnel, and any other factors which may cause collision.

Do not operate a machine in the path of any crane or moving overhead machinery unless the controls of the crane have been locked out and/or precautions have been taken to prevent any potential collision.

No stunt driving or horseplay while operating a machine.

### **⚠ Bodily Injury Hazard**

Do not operate the machine with a hydraulic oil or air leak. An air leak or hydraulic leak can penetrate and/or burn skin.

Improper contact with components under any cover will cause serious injury. Only trained maintenance personnel should access compartments. Access by the operator is only advised when performing a pre-operation inspection. All compartments must remain closed and secured during operation.

### **⚠ Explosion and Fire Hazards**

Do not operate the machine or charge the battery in hazardous locations or locations where potentially flammable or explosive gases or particles may be present.

### **⚠ Damaged Machine Hazards**

Do not use a damaged or malfunctioning machine.

Conduct a thorough pre-operation inspection of the machine and test all functions before each work shift. Immediately tag and remove from service a damaged or malfunctioning machine.

Be sure all maintenance has been performed as specified in this manual and the appropriate Genie service manual.

Be sure all decals are in place and legible.

Be sure the operator's, safety, and responsibilities manuals are complete, legible, and in the storage container located on the machine.

### **⚠ Component Damage Hazards**

Do not use any battery charger greater than 24V to charge the batteries.

Do not use the machine as a ground for welding.

## Work Area Safety

### ▲ Battery Safety

#### Burn Hazards



Batteries contain acid. Always wear protective clothing and eye wear when working with batteries.

Avoid spilling or contacting battery acid. Neutralize battery acid spills with baking soda and water.

Do not expose the batteries or the charger to water or rain during charging.

#### Explosion Hazards



Keep sparks, flames, and lighted tobacco away from batteries. Batteries emit explosive gas.

The battery tray may remain open during the entire charging cycle.

Do not contact the battery terminals or the cable clamps with tools that may cause sparks.

#### Component Damage Hazard

Do not use any battery charger greater than 24V to charge the batteries.

#### Electrocution/Burn Hazards



Connect the battery charger to a grounded, AC 3-wire electrical outlet only.

Inspect daily for damaged cords, cables and wires. Replace damaged items before operating.

Avoid electrical shock from contact with battery terminals. Remove all rings, watches and other jewelry.

#### Lifting Hazard

Use the appropriate number of people and proper lifting techniques when lifting batteries.

#### Lockout After Each Use

- 1 Select a safe parking location—firm level surface, clear of obstruction and traffic.
- 2 Lower the platform.
- 3 Turn the key switch to the off position and remove the key to secure from unauthorized use.
- 4 Charge the batteries.



# Legend

GS-1530  
 GS-1532  
 GS-1930  
 GS-1932  
 GS-1932 XH

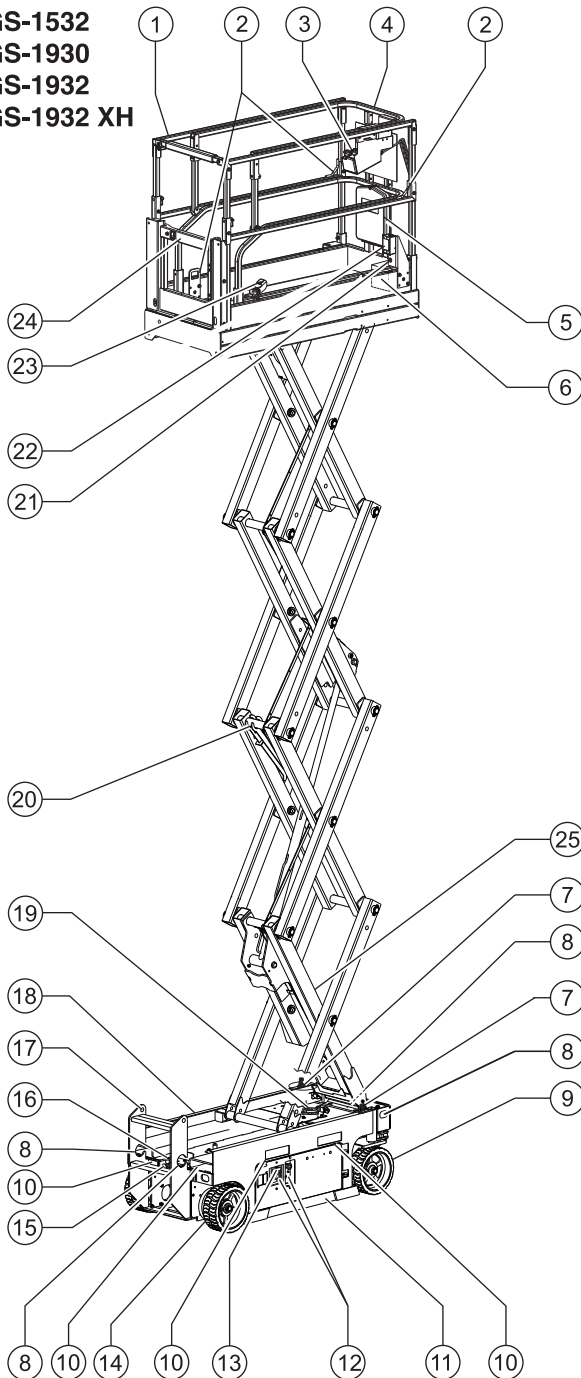

- 1 Platform guard rails
- 2 Lanyard anchorage points
- 3 Platform controls
- 4 Platform extension
- 5 Manual storage container
- 6 Foot switch (if equipped)
- 7 Flashing beacon
- 8 Transport tie-down
- 9 Steer tire
- 10 Forklift pocket
- 11 Pothole guard
- 12 Ground controls
- 13 LCD readout
- 14 Non-steer tire
- 15 Auxiliary lowering knob
- 16 Brake release pump (hydraulic drive models) or Brake release switch (E-drive models)
- 17 Entry ladder / transport tie-down
- 18 Battery charger (on battery side of machine)
- 19 Tilt alarm
- 20 Safety arm
- 21 Air line to platform (optional)
- 22 GFCI outlet
- 23 Platform extension release pedal
- 24 Platform entry gate
- 25 Inverter (optional)

# Legend

GS-2032  
GS-2632  
GS-3232

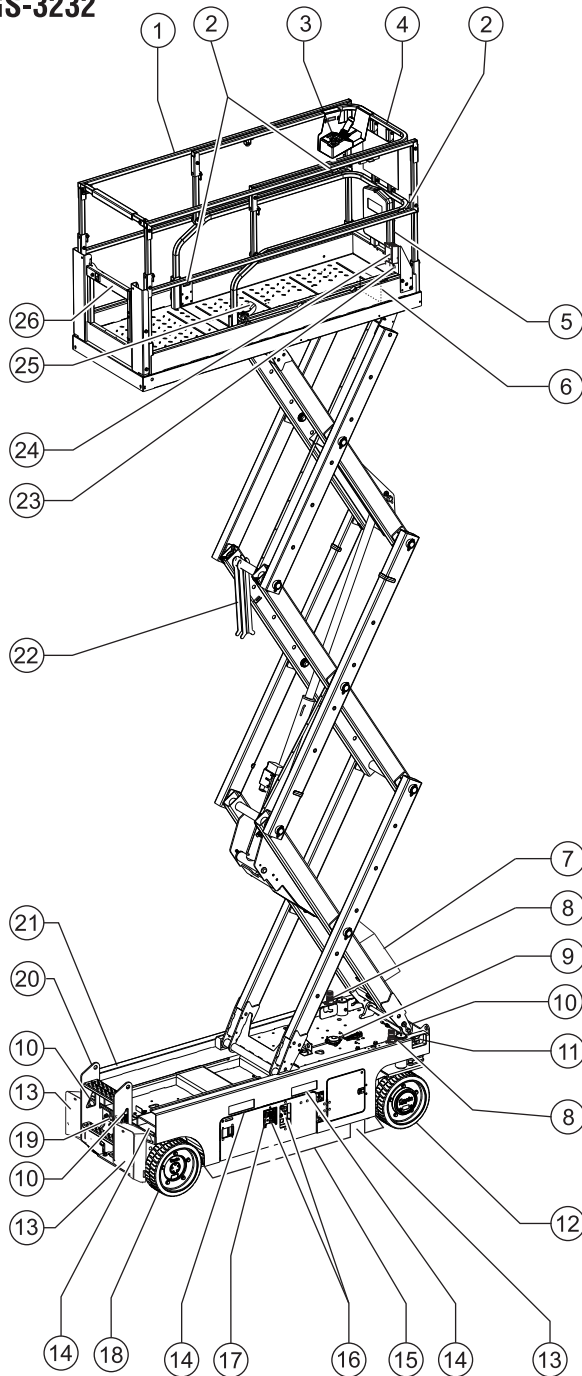

- 1 Platform guard rails
- 2 Lanyard anchorage points
- 3 Platform controls
- 4 Platform extension
- 5 Manual storage container
- 6 Foot switch (if equipped)
- 7 Inverter (optional)
- 8 Flashing beacon
- 9 Tilt alarm
- 10 Transport tie-down
- 11 Auxiliary lowering knob
- 12 Steer tire
- 13 Outrigger (GS-3232 only)
- 14 Forklift pocket
- 15 Pothole guard
- 16 Ground controls
- 17 LCD readout
- 18 Non-steer tire
- 19 Brake release pump (hydraulic drive models)  
or Brake release switch (E-drive models)
- 20 Entry ladder / transport tie-down
- 21 Battery charger (on battery side of machine)
- 22 Safety arm
- 23 Air line to platform (optional)
- 24 GFCI outlet
- 25 Platform extension release pedal
- 26 Platform entry gate

# Legend

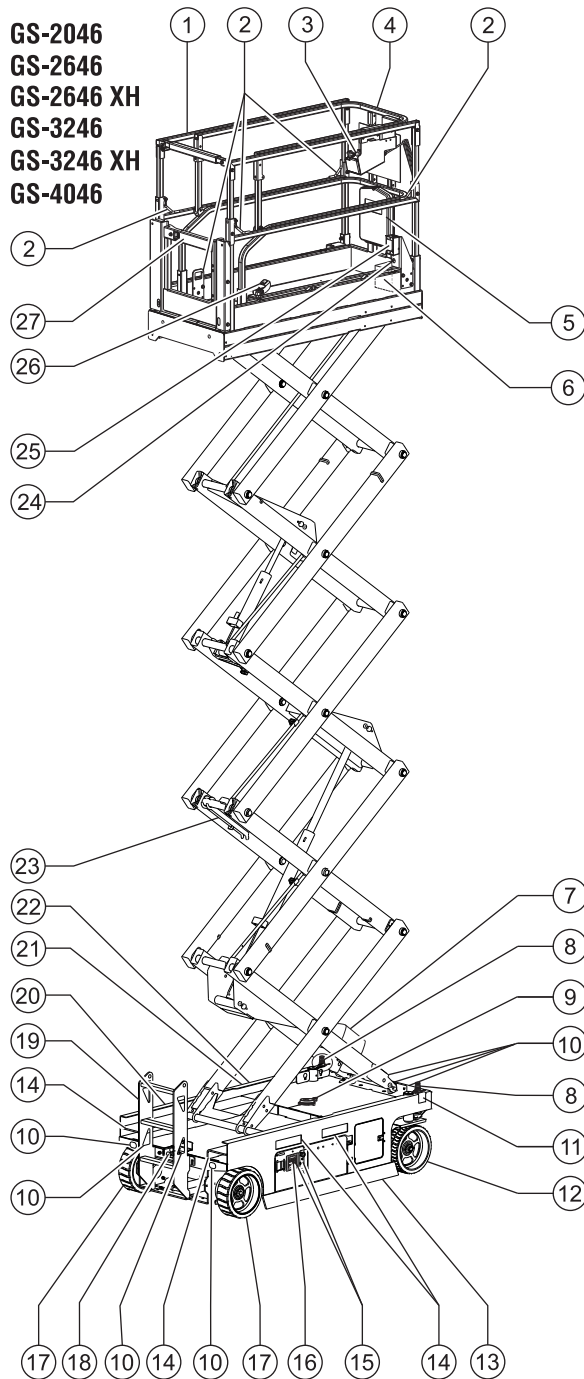

- 1 Platform guard rails
- 2 Lanyard anchorage points
- 3 Platform controls
- 4 Platform extension
- 5 Manual storage container
- 6 Foot switch (if equipped)
- 7 Inverter (optional), GS-46
- 8 Flashing beacon
- 9 Tilt alarm
- 10 Transport tie-down
- 11 Auxiliary lowering knob
- 12 Steer tire
- 13 Pothole guard
- 14 Forklift pocket
- 15 Ground controls
- 16 LCD readout
- 17 Non-steer tire
- 18 Brake release switch
- 19 Entry ladder / transport tie-down
- 20 Battery charger (on battery side of machine)  
GS-4046
- 21 Inverter (optional)
- 22 Battery charger (on battery side of machine)
- 23 Safety arm
- 24 Air line to platform (optional)
- 25 GFCI outlet
- 26 Platform extension release pedal
- 27 Platform entry gate

## Controls

The ground control station is to be used as a means to raise the platform for function tests and for storage purposes. The ground control station can be used in the event of an emergency to rescue an incapacitated person in the platform.

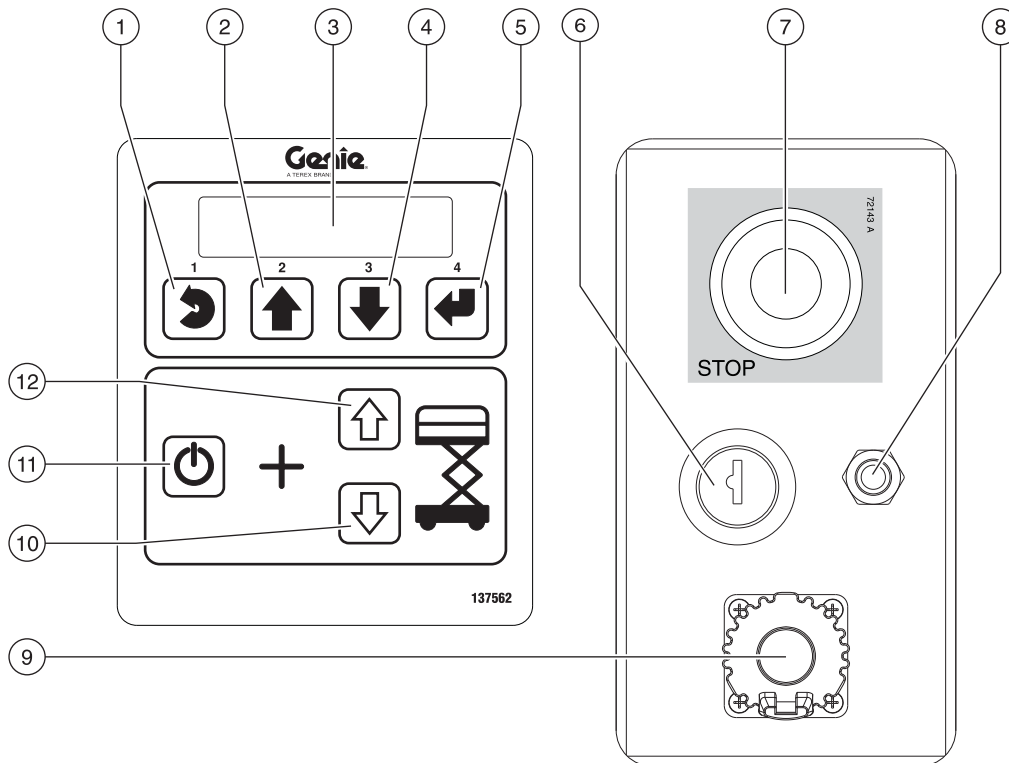

### Ground Control Panel

- |  |   |
|--|---|
| <ul style="list-style-type: none"> <li>1 Menu escape button</li> <li>2 Menu up button</li> <li>3 LCD diagnostic readout</li> <li>4 Menu down button</li> <li>5 Menu enter button</li> <li>6 Key switch for platform/off/ground selection<br/>Turn the key switch to the platform position and the platform controls will operate. Turn the key switch to the off position and the machine will be off. Turn the key switch to the ground position and the ground controls will operate.</li> </ul> | <ul style="list-style-type: none"> <li>7 Red Emergency Stop button<br/>Push in the red Emergency Stop button to the off position to stop all functions. Pull out the red Emergency Stop button to the on position to operate the machine.</li> <li>8 7A breaker for electrical circuits</li> <li>9 Tech Pro Link Connector</li> <li>10 Platform down button</li> <li>11 Lift function enable button<br/>Press and hold this button to activate the lift function.</li> <li>12 Platform up button</li> </ul> |
|--|---|

# Controls

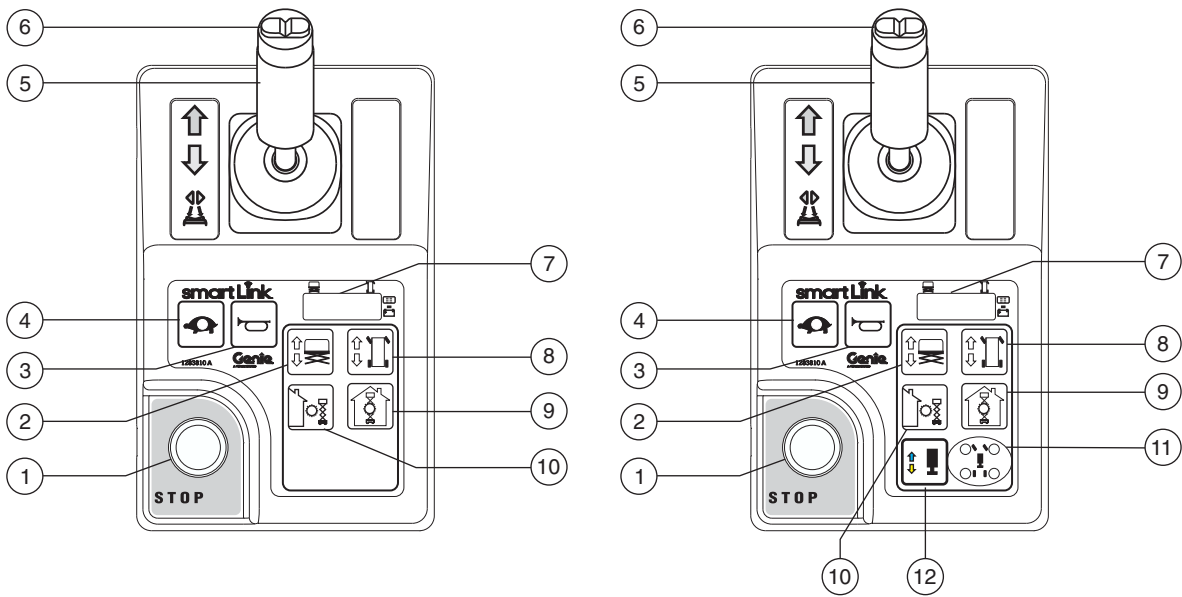

## Platform Control Panel

### 1 Red Emergency Stop button

Push in the red Emergency Stop button to the off position to stop all functions. Pull out the red Emergency Stop button to the on position to operate the machine.

### 2 Lift function button

Push this button to activate the lift function.

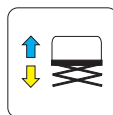

### 3 Horn button

Press the horn button and the horn will sound. Release the horn button and the horn will not sound.



### 4 Drive speed select button

Press this button to activate the slow drive function. The indicator light will be on when slow drive is selected.



## Controls

- 5 Proportional control handle and function enable switch for drive, steer, lift and outrigger functions

Lift function: Press and hold the function enable switch to enable the lift function on the platform control handle. Move the control handle in the direction indicated by the blue arrow and the platform will raise. Move the control handle in the direction indicated by the yellow arrow and the platform will lower. The descent alarm should sound while the platform is lowering.

Drive function: Press and hold the function enable switch to enable the drive function on the platform control handle. Move the control handle in the direction indicated by the blue arrow on the control panel and the machine will move in the direction that the blue arrow points. Move the control handle in the direction indicated by the yellow arrow on the control panel and the machine will move in the direction that the yellow arrow points.

Outrigger function: Press and hold the function enable switch to enable the outrigger function on the platform control handle. Move the control handle in the direction indicated by the blue arrow and the outriggers will retract. Move the control handle in the direction indicated by the yellow arrow and the outriggers will extend.

- 6 Thumb rocker switch for steer function

Press the left side of the thumb rocker and the machine will turn in the direction the blue triangle points on the platform control panel.



Press the right side of the thumb rocker and the machine will turn in the direction the yellow triangle points on the platform control panel.



- 7 LED diagnostic readout / battery charge indicator and mode indicator.
- 8 Drive function button

Push this button to activate the drive function.

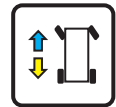

- 9 Indoor use button

Press this button for indoor use

Note: Selecting indoor use permits elevating to maximum indoor platform height. Refer to specification pages.



# Controls

## 10 Outdoor use button

Press this button for outdoor use

Note: Selecting outdoor use permits elevating to maximum outdoor platform height. Refer to specification pages.

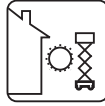

## 11 Outrigger indicator lights

During outrigger extension, lights flash green. As each outrigger contacts the ground, lights turn solid green. Any time the outrigger extension procedure is interrupted, the lights will flash green indicating the outriggers are not contacting the ground or the outriggers are not fully deployed. During outrigger retraction lights turn solid green. As each outrigger fully retracts, lights turn off. Lights will turn solid red, indicating the corresponding outrigger is at end of stroke.

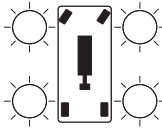

## 12 Outrigger function button

Press this button to activate the outrigger function.

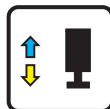

# Inspections



---

## Do Not Operate Unless:

- You learn and practice the principles of safe machine operation contained in this operator's manual.
  - 1 Avoid hazardous situations.
  - 2 **Always perform a pre-operation inspection.**
- Know and understand the pre-operation inspection before going on to the next section.**
  - 3 Always perform function tests prior to use.
  - 4 Inspect the workplace.
  - 5 Only use the machine as it was intended.

## Pre-operation Inspection Fundamentals

It is the responsibility of the operator to perform a pre-operation inspection and routine maintenance.

The pre-operation inspection is a visual inspection performed by the operator prior to each work shift. The inspection is designed to discover if anything is apparently wrong with a machine before the operator performs the function tests.

The pre-operation inspection also serves to determine if routine maintenance procedures are required. Only routine maintenance items specified in this manual may be performed by the operator.

Refer to the list on the next page and check each of the items.

If damage or any unauthorized variation from factory delivered condition is discovered, the machine must be tagged and removed from service.

Repairs to the machine may only be made by a qualified service technician, according to the manufacturer's specifications. After repairs are completed, the operator must perform a pre-operation inspection again before going on to the function tests.

Scheduled maintenance inspections shall be performed by qualified service technicians, according to the manufacturer's specifications and the requirements listed in the responsibilities manual.



# Inspections

## Pre-operation Inspection

- Be sure that the operator's, safety, and responsibilities manuals are complete, legible and in the storage container located in the platform.
- Be sure that all decals are legible and in place. See Inspections section.
- Check for hydraulic oil leaks and proper oil level. Add oil if needed. See Maintenance section.
- Check for battery fluid leaks and proper fluid level. Add distilled water if needed. See Maintenance section.

Check the following components or areas for damage, improperly installed, or missing parts and unauthorized modifications:

- Electrical components, wiring, and electrical cables
- Hydraulic hoses, fittings, cylinders, and manifolds
- Drive motors
- Wear pads
- Tires and wheels
- Limit switches, alarms and horn
- Beacons (if equipped)
- Nuts, bolts and other fasteners
- Brake release components

- Safety arm
- Platform extension
- Scissor pins and retaining fasteners
- Platform control joystick
- Battery pack and connections
- Ground strap
- Platform entry gate
- Pothole guards
- Lanyard anchorage points
- Platform overload components
- Outrigger housing and footpads (if equipped)

Check entire machine for:

- Cracks in welds or structural components
- Dents or damage to machine
- Excessive rust, corrosion or oxidation
- Verify that all structural and other critical components are present and all associated fasteners and pins are in place and properly tightened.
- Be sure side rails are installed and bolts are fastened.
- Be sure that the chassis trays are closed and latched and the batteries are properly connected.

Note: If the platform must be raised to inspect the machine, make sure the safety arm is in place. See Operating Instructions section.

# Inspections



---

## Do Not Operate Unless:

- You learn and practice the principles of safe machine operation contained in this operator's manual.
  - 1 Avoid hazardous situations.
  - 2 Always perform a pre-operation inspection.
  - 3 **Always perform function tests prior to use.**

**Know and understand the function tests before going on to the next section.**

- 4 Inspect the workplace.
- 5 Only use the machine as it was intended.

## Function Test Fundamentals

The function tests are designed to discover any malfunctions before the machine is put into service. The operator must follow the step-by-step instructions to test all machine functions.

A malfunctioning machine must never be used. If malfunctions are discovered, the machine must be tagged and removed from service. Repairs to the machine may only be made by a qualified service technician, according to the manufacturer's specifications.

After repairs are completed, the operator must perform a pre-operation inspection and function tests again before putting the machine into service.

# Inspections

## At the Ground Controls

- 1 Select a test area that is firm, level and free of hazards.
- 2 Be sure the batteries are connected.
- 3 Pull out the platform and ground red Emergency Stop button to the on position.
- 4 Turn the key switch to ground control.
- 5 Observe the diagnostic LED readout on the platform controls.
- ⊙ Result: The LED should look like the picture below.



- 6 Observe the diagnostic LCD readout on the ground controls.
- ⊙ Result: The LCD should look like the picture below.

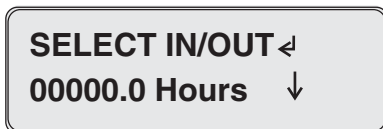

## Test Emergency Stop

- 7 Push in the ground red Emergency Stop button to the off position.
- ⊙ Result: No functions should operate.
- 8 Pull out the red Emergency Stop button to the on position.

## Test the Up/Down Functions

The audible warnings on this machine and the standard horn all come from the same central alarm. The horn is a constant tone. The descent alarm sounds at 60 beeps per minute. The alarm sounds at 180 beeps per minute when the pothole guards have not deployed and when the machine is not level. An optional automotive-style horn is also available.

- 9 Do not press the lift function enable button.
- 10 Press the platform up or platform down button.
- ⊙ Result: The lift function should not operate.
- 11 Do not press the platform up or platform down buttons.
- 12 Press the lift function enable button.
- ⊙ Result: The lift function should not operate.
- 13 Press and hold the lift function enable button, and press the platform up button.
- ⊙ Result: The outdoor area of operation should be selected and the platform should raise.
- 14 Press and hold the lift function enable button, and press the platform down button.
- ⊙ Result: The platform should lower. The descent alarm should sound while the platform is lowering.

# Inspections

## Test Auxiliary Lowering

- 15 Activate the up function by pressing the lift enable button and platform up button, and raise the platform approximately 2 ft. / 60 cm.
- 16 **GS-1530, GS-1532, GS-1930, GS-1932 & GS-1932 XH Models**

Pull the auxiliary lowering knob located behind the entry ladder.

**GS-2032, GS-2632, GS-3232, GS-2046, GS-2646, GS-2646 XH, GS-3246, GS-3246 XH & GS-4046 Models**

Pull the auxiliary lowering knob located on the ground controls side of the machine, at the steer end.

- ⊙ Result: The platform should lower. The descent alarm will not sound.

## Test the Tilt Sensor Operation

- 17 Press the ground control down button (button 3)



- ⊙ Result: The ground control LCD screen will display the status of the tilt sensor. For all models except the GS-3232 the X and Y values (pitch and roll) will be displayed. For the GS-3232, the GCON shall display "TILT SENSOR: LEVEL".
- 18 Turn the key switch to platform control.

## At the Platform Controls

### Test Emergency Stop

- 19 Push in the platform red Emergency Stop button to the off position.
- ⊙ Result: No functions should operate.

### Test the Alarm for Tilt Sensor

- 20 Pull out the red Emergency Stop button to the on position.
- 21 Press the horn button.
- ⊙ Result: The platform alarm, chassis alarm, and automotive horn (if equipped) should sound.

## Inspections

### Test the Function Enable Switch and the Up/Down Functions

- 22 Do not hold the function enable switch on the control handle.
- 23 Slowly move the control handle in the direction indicated by the blue arrow, then in the direction indicated by the yellow arrow.
  - ⊙ Result: No functions should operate.
- 24 Press the lift function button.
- 25 Wait seven seconds for the lift function to time out.
- 26 Slowly move the control handle in the direction indicated by the blue arrow, then in the direction indicated by the yellow arrow.
  - ⊙ Result: The lift function should not operate.
- 27 Press the lift function button.
- 28 Press and hold the function enable switch on the control handle. Slowly move the control handle in the direction indicated by the blue arrow.

Machines equipped with foot switch: Press and hold the foot switch and press and hold the function enable switch on the control handle at the same time.

- ⊙ Result: The platform should raise. The pothole guards should deploy. The outdoor use button should illuminate.

- 29 Release the control handle.
  - ⊙ Result: The platform should stop raising.
- 30 Press and hold the function enable switch on the control handle. Slowly move the control handle in the direction indicated by the yellow arrow.
  - ⊙ Result: The platform should lower. The descent alarm should sound while the platform is lowering.

# Inspections

## Test the Outdoor Use Button

31 Do not press and hold the function enable switch on control handle.

32 Press the outdoor use button.

⊙ Result: The LED under the outdoor button will illuminate.

33 Press the lift function enable button.

34 Press and hold the function enable switch on the control handle. Slowly move the control handle in the direction indicated by the blue arrow.

⊙ **GS-1530:** Result: The platform should raise to a maximum of 12 ft 8 in/3.86 m and stop. The alarm should sound. The platform controls LED readout should display OHL.

⊙ **GS-1532:** Result: The platform should raise to a maximum of 12 ft 8 in/3.86 m and stop. The alarm should sound. The platform controls LED readout should display OHL.

⊙ **GS-1930/32:** Result: The platform should raise to a maximum of 14 ft 8 in/4.47 m and stop. The alarm should sound. The platform controls LED readout should display OHL.

⊙ **GS-1932XH:** Result: The platform should raise to a maximum of 19 ft 3 in/5.85 m and stop. The alarm should sound. The platform controls LED readout should display OHL.

⊙ **GS-2032:** Result: The platform should raise to a maximum of 16 ft/4.88 m and stop. The alarm should sound. The platform controls LED readout should display OHL.

⊙ **GS-2632:** Result: The platform should raise to a maximum of 19 ft/5.79 m and stop. The alarm should sound. The platform controls LED readout should display OHL.

⊙ **GS-3232 (on wheels):** Result: The platform should raise to a maximum of 15 ft 9 in/4.80 m and stop. The alarm should sound. The platform controls LED readout should display OHL.

⊙ **GS-2046:** Result: The platform should raise to a maximum of 16 ft 4 in/4.98 m and stop. The alarm should sound. The platform controls LED readout should display OHL.

⊙ **GS-2646:** Result: The platform should raise to a maximum of 19 ft 8 in/5.99 m and stop. The alarm should sound. The platform controls LED readout should display OHL.

⊙ **GS-2646XH:** Result: The platform should raise to a maximum of 26 ft 1 in/7.96 m and stop. The alarm should sound. The platform controls LED readout should display OHL.

⊙ **GS-3246:** Result: The platform should raise to a maximum of 22 ft/6.71 m and stop. The alarm should sound. The platform controls LED readout should display OHL.

⊙ **GS-3246XH:** Result: The platform should raise to a maximum of 32 ft 1 in/9.78 m and stop. The alarm should sound. The platform controls LED readout should display OHL.

⊙ **GS-4046:** Result: The platform should raise to a maximum of 23 ft/7.01 m and stop. The alarm should sound. The platform controls LED readout should display OHL.

# Inspections

## Test the Drive Function Button

35 Press the drive function button.

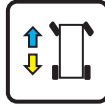

36 Wait seven seconds for the drive function to time out. Slowly move the control handle in the direction indicated by the blue arrow, then in the direction indicated by the yellow arrow.

⦿ Result: No functions should operate.

## Test the Steering

Note: When performing the steer and drive function tests, stand in the platform facing the steer end of the machine.

37 Press the drive function button.

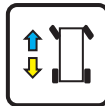

38 Press and hold the function enable switch on the control handle.

39 Press the thumb rocker switch on top of the control handle in the direction indicated by the blue triangle on the control panel.

⦿ Result: The steer wheels should turn in the direction indicated by the blue triangle.

40 Press the thumb rocker switch on top of the control handle in the direction indicated by the yellow triangle, on the control panel.

⦿ Result: The steer wheels should turn in the direction indicated by the yellow triangle.

## Test Drive and Braking

41 Press the drive function button.

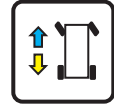

42 Press and hold the function enable switch on the control handle.

Machines equipped with foot switch: Press and hold the foot switch and press and hold the function enable switch on the control handle at the same time.

43 Slowly move the control handle in the direction indicated by the blue arrow on the control panel until the machine begins to move, then return the control handle to the center position.

⦿ Result: The machine should move in the direction that the blue arrow points on the control panel, then come to an abrupt stop when the control handle is returned to the center position.

44 Slowly move the control handle in the direction indicated by the yellow arrow on the control panel until the machine begins to move, then return the control handle to the center position.

⦿ Result: The machine should move in the direction that the yellow arrow points on the control panel, then come to an abrupt stop when the control handle is returned to the center position.

Note: The brakes must be able to hold the machine on any slope it is able to climb.

# Inspections

## Test the Tilt Sensor Operation (GS-3232 only)

Note: Perform this test from the ground with the platform controller. Do not stand in the platform.

- 45 Fully lower the platform.
- 46 Place a 2x4 or similar piece of wood under both wheels on one side and drive the machine up onto them.
- 47 Raise the platform approximately 7 ft / 2.13 m.
- ⊙ Result: The platform should stop and the tilt alarm will sound at 180 beeps per minute. The platform controls LED readout should display LL and the ground controls LCD should display LL: Machine Tilted.
- 48 Press the drive function button.

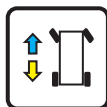

- 49 Press and hold the function enable switch on the control handle.
- 50 Move the control handle in the direction indicated by the blue arrow, then move the control handle in the direction indicated by the yellow arrow.
- ⊙ Result: The drive function should not work in either direction.
- 51 Lower the platform and remove both pieces of wood.

## Test Drive Tilt Cutout

Note: Perform this test from the ground with the platform controller. Do not stand in the platform.

- 52 Fully lower the platform.
- 53 Drive the machine onto a slope where the chassis angle is greater than 1.5° side to side.
- 54 Raise the platform to approximately 9 ft/2.74 m.
- ⊙ Result: The platform should stop and the tilt alarm will sound at 180 beeps per minute. The platform controls LED readout should display LL and the ground controls LCD should display LL: Machine Tilted.
- 55 Press the drive function button.
- 56 Press and hold the function enable switch on the control handle.
- 57 Move the control handle in the direction indicated by the blue arrow, then move the control handle in the direction indicated by the yellow arrow.
- ⊙ Result: The drive function should not work in either direction.
- 58 Fully lower the platform.
- 59 Drive the machine.
- ⊙ Result: The machine should drive.
- 60 Return to level ground and raise the platform in excess of approximately 9 ft/2.74 m.



## Inspections

- 61 Drive the machine onto a slope where the pitch angle is greater than 1.5° side to side.
- ⊙ Result: The machine should stop once the machine reaches 1.5° of chassis tilt and the tilt alarm will sound at 180 beeps per minute. The platform controls LED readout should display LL and the ground controls LCD should display LL: Machine Tilted
- 62 Return to level ground and fully lower the platform.
- 63 Drive the machine onto a slope where the chassis angle is greater than 3° front to back.
- 64 Raise the platform to approximately 9 ft/2.74 m.
- ⊙ Result: The platform should stop and the tilt alarm will sound at 180 beeps per minute. The platform controls LED readout should display LL and the ground controls LCD should display LL: Machine Tilted.
- 65 Press the drive function button.
- 66 Press and hold the drive/steer function enable switch on the control handle.
- 67 Move the control handle in the direction indicated by the blue arrow, then move the control handle in the direction indicated by the yellow arrow.
- ⊙ Result: The drive function should not work in either direction.

68 Fully lower the platform.

69 Drive the machine.

- ⊙ Result: The machine should drive.

70 Return to level ground and raise the platform in excess of approximately 9 ft/2.74 m.

71 Drive the machine onto a slope where the pitch angle is greater than 3° front to back.

- ⊙ Result: The machine should stop once the machine reaches 3° of chassis tilt and the tilt alarm will sound at 180 beeps per minute. The platform controls LED readout should display LL and the ground controls LCD should display LL: Machine Tilted

- ⊙ Fully lower the platform and return to level ground.

### Test Elevated Drive Speed

72 Raise the platform approximately 9.1 ft/2.78 m from the ground.

73 Press the drive function button.

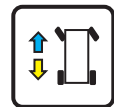

74 Press and hold the function enable switch on the control handle. Slowly move the control handle to full drive position.

- ⊙ Result: The maximum achievable drive speed with the platform raised should not exceed 0.72 ft / 22 cm per second.

If the drive speed with the platform raised exceeds 0.72 ft / 22 cm per second, immediately tag and remove the machine from service.

# Inspections

## Test the Pothole Guards

Note: The pothole guards should automatically deploy when the platform is raised. The pothole guards activate limit switches that allow the machine to continue to function. If the pothole guards do not deploy, an alarm sounds and the machine will not drive or steer.

75 Raise the platform.

- ⊙ Result: When the platform is raised 4 ft / 1.2 m from the ground, the pothole guards should deploy.

76 Press on the pothole guards on one side, and then the other.

- ⊙ Result: The pothole guards should not move.

77 Lower the platform.

- ⊙ Result: The pothole guards should return to the stowed position.

78 Place a 2x4 or similar piece of wood under a pothole guard.

79 Raise the platform.

- ⊙ Result: Before the platform is raised 7 ft / 2.1 m from the ground, an alarm should sound. The platform controls LED readout should display PHS and the ground controls LCD should display PHS: Pothole Guard Stuck.

80 Press the drive function button.

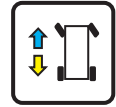

81 Press and hold the function enable switch on the control handle.

82 Slowly move the control handle in the direction indicated by the blue arrow, then in the direction indicated by the yellow arrow.

- ⊙ Result: The machine should not move forward or backward.

83 Press the drive function button.

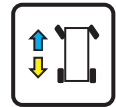

84 Press and hold the function enable switch on the control handle.

85 Press the thumb rocker switch on top of the control handle in the direction indicated by the blue and yellow triangles on the control panel.

- ⊙ Result: The steer wheels should not turn left or right.

86 Fully lower the platform.

87 Remove the 2x4 or similar piece of wood.

# Inspections

## Test the Outrigger Function (GS-3232)

- 88 Press the outrigger function button.  
On the LCD screen, a circle below the outrigger function symbol will turn on.

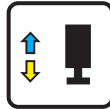

If the control handle is not moved within seven seconds of pushing the outrigger function button, the circle below the outrigger function symbol will turn off and outrigger function will not operate. Press the outrigger function button again.

- 89 Press and hold the function enable switch on the control handle.
- 90 Move the control handle in the direction indicated by the yellow arrow.
- ⊙ Result: The outriggers should extend. The individual outrigger indicator lights will flash green as the corresponding outrigger extends.
- 91 Continue holding the control handle in the direction indicated by the yellow arrow until all outrigger indicator lights turn solid green and a long beep is heard from the platform controls alarm. The machine is now level. At this point, the drive and steer functions are disabled.

Note: If the control handle or foot switch (if equipped) are released too soon during extension, the outrigger indicator lights will continue to flash green, indicating the outriggers are not contacting the ground.

Note: If the control handle or foot switch (if equipped) are released too soon after the outriggers have contacted the ground, a long beep will not be heard at the platform controls and the outrigger indicator lights will be solid green. If a long beep is not heard and the outrigger indicator lights are solid green, this condition may indicate the outriggers are not fully deployed or the machine is not level.

- 92 Press the drive function button.
- 93 Press and hold the function enable switch on the control handle.
- 94 Slowly move the control handle in the direction indicated by the blue arrow, then in the direction indicated by the yellow arrow.
- ⊙ Result: The machine should not move in the directions indicated by the blue and yellow arrows.
- 95 Press the drive function button.
- 96 Press and hold the function enable switch on the control handle.
- 97 Press the thumb rocker switch on top of the control handle in the direction indicated by the blue and yellow triangles on the control panel.
- ⊙ Result: The steer wheels should not turn in the directions indicated by the blue and yellow triangles.
- 98 Press the outdoor use button.
- 99 Raise the platform.
- ⊙ Result: The platform should raise to a maximum of 18 ft 0 in/6.71 m. The alarm should sound. The platform controls LED readout should display OHL.
- 100 Fully lower the platform.
- 101 Press the outrigger function button.

---

# Inspections

102 Wait seven seconds for the outrigger function enable to time out.

103 Slowly move the control handle in the direction indicated by the blue arrow, then in the direction indicated by the yellow arrow.

⊙ Result: The outriggers should not retract.

104 Press the outrigger function button.

105 Move the control handle in the direction indicated by the blue arrow.

⊙ Result: The outriggers should retract. The individual outrigger indicator lights will turn solid green as the corresponding outrigger retracts.

106 Continue holding the control handle and the foot switch (if equipped) until the outriggers are completely retracted. Release the control handle when all outrigger indicator lights turn off. All functions are now restored.

Note: If the control handle or foot switch (if equipped) are released too soon during retraction, the outrigger indicator lights will flash green, indicating the outriggers are not fully retracted.

# Inspections



## Do Not Operate Unless:

- You learn and practice the principles of safe machine operation contained in this operator's manual.
  - 1 Avoid hazardous situations.
  - 2 Always perform a pre-operation inspection.
  - 3 Always perform function tests prior to use.
  - 4 Inspect the workplace.**

**Know and understand the workplace inspection before going on to the next section.**
  - 5 Only use the machine as it was intended.

## Workplace Inspection Checklist

Be aware of and avoid the following hazardous situations:

- drop-offs or holes
- bumps, floor obstructions, or debris
- sloped surfaces
- unstable or slippery surfaces
- overhead obstructions and high voltage conductors
- hazardous locations
- inadequate surface support to withstand all load forces imposed by the machine
- wind and weather conditions
- the presence of unauthorized personnel
- other possible unsafe conditions

## Workplace Inspection Fundamentals

The workplace inspection helps the operator determine if the workplace is suitable for safe machine operation. It should be performed by the operator prior to moving the machine to the workplace.

It is the operator's responsibility to read and remember the workplace hazards, then watch for and avoid them while moving, setting up, and operating the machine.

## Inspections

### Inspection for Decals with Symbols GS-1530, GS-1532, GS-1930 and GS-1932

Determine whether the decals on your machine have words or symbols. Use the appropriate inspection to verify that all decals are legible and in place.

Part No.	Decal Description	Qty
28174	Label – Power to Platform, 230V*	2
28235	Label – Power to Platform, 115V*	2
38149	Label – Patent	1
43618	Label – Directional Arrows	2
43658	Label – Power to Charger, 230V*	1
44980	Label – Power to Charger, 115V*	1
44981	Label – Air Line to Platform*	2
52475	Label – Transport Tie-down	4
72086	Label – Lifting Point	4
72143	Label – Emergency Stop	1
82474	Label – Use Safety Chock	2
82481	Label – Battery/Charger Safety	1
82487	Label – Read the Manual	2
82495	Label – Brake Release Safety and Operating Instructions	1
82666	Label - Forklift Pocket	4
97719	Label – Safety Arm	1
114337	Label – Tip-over Hazard, Limit Switch	1
114338	Label – Tip-over Hazard, Tilt Alarm	1
137605	Label – Emergency Stop, Platform Control	1
137656	Label – Drive/Steer Direction, Platform Control	1
1263542	Label – Compartment Access	2
1272242	Label – Machine Registration/Owner Transfer	1

Part No.	Decal Description	Qty
1278704	Label – Battery Charger Indicator	1
1281174	Label – Lanyard Anchorage Point, Fall Arrest/Fall Restrained	3
1283810	Label – Platform Control Panel	1
1283878	Label – Tech Pro Link	1
1284982	Warning – Explosion Hazard, Accumulator	1
1290673	Label – Electrocutation Hazard, Plug	1
1290699	Label – Transport Diagram	2
1292990	Label – Release Brake	1
1293166	Danger, Warning – Tip-over, Crush Hazard	1
1293217	Label – Danger, Electrocutation Hazard	3
1294688	Label – Platform Overload LED Indicator Light	1
1296034	Label – Smartlink Dual Zone	2
1296299	Danger – Max. Capacity, Side Force, GS-1530*	1
1296301	Danger – Max. Capacity, Side Force, GS-1930/32, GS-2632, GS-3232*	1
1298467	Label – Read the Manual, (panel cradle)*	2
1298467	Label – Read the Manual, (pipe cradle)*	2
1298467	Label – Read the Manual, (work tray)*	1
1298834	Danger – Tip-over Hazard, Batteries	1
1305532	Label – Wheel Load, E-drive, GS-1530/32	4
1305533	Label – Wheel Load, E-drive, GS-1930	4
1305534	Label – Wheel Load, E-drive, GS-1932	4
T112804	Label – Ground Control Panel	1

\* These decals are model, option or configuration specific.

 Shading indicates decal is hidden from view, i.e. under covers

# Inspections

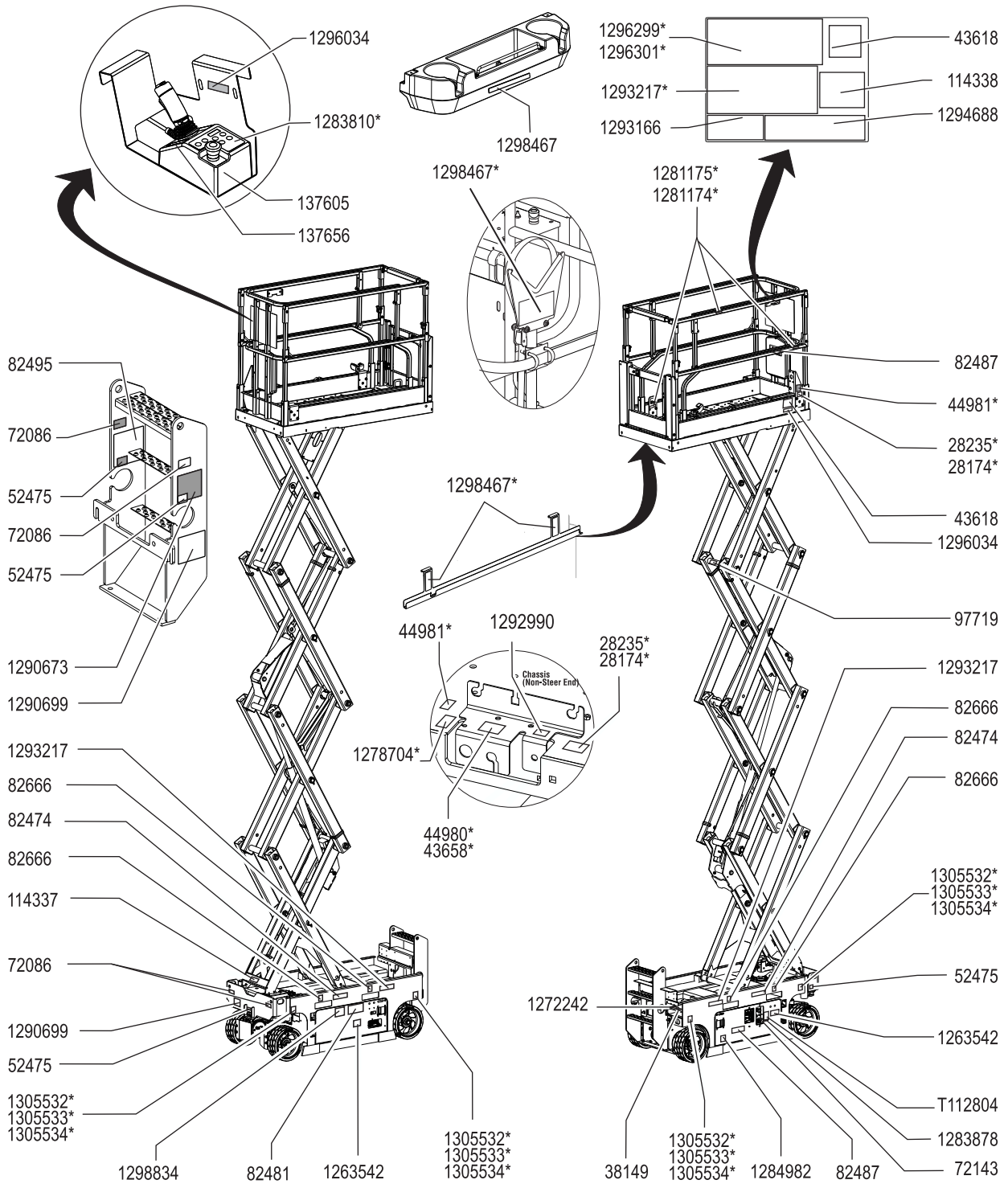

## Inspections

### Inspection for Decals with Symbols GS-2032, GS-2632 and GS-3232

Determine whether the decals on your machine have words or symbols. Use the appropriate inspection to verify that all decals are legible and in place.

Part No.	Decal Description	Qty
28174	Label – Power to Platform, 230V*	2
28235	Label – Power to Platform, 115V*	2
38149	Label – Patent	1
43618	Label – Directional Arrows	2
43658	Label – Power to Charger, 230V*	1
44980	Label – Power to Charger, 115V*	1
44981	Label – Air Line to Platform*	2
52475	Label – Transport Tie-down	3
72086	Label – Lifting Point	4
72143	Label – Emergency Stop	1
82474	Label – Use Safety Chock	2
82475	Label – Crushing Hazard, Outriggers(GS-3232 only)*	3
82481	Label – Battery/Charger Safety	2
82482	Label – Emergency Lowering	1
82487	Label – Read the Manual	2
82495	Label – Brake Release Safety and Operating Instructions	1
82666	Label - Forklift Pocket	4
97719	Label – Safety Arm	1
114337	Label – Tip-over Hazard, Limit Switch	1
114338	Label – Tip-over Hazard, Tilt Alarm	1
137605	Label – Emergency Stop, Platform Control	1
137656	Label – Drive/Steer Direction, Platform Control	1
1263542	Label – Compartment Access	2
1272242	Label – Machine Registration/Owner Transfer	1

Part No.	Decal Description	Qty
1278704	Label – Battery Charger Indicator	1
1281174	Label – Lanyard Anchorage Point, Fall Arrest/Fall Restrained	3
1283810	Label – Platform Control Panel	1
1283812	Label – O/R Dual Zone, GS	1
1283878	Label – Tech Pro Link	1
1284982	Warning – Explosion Hazard, Accumulator	1
1290673	Label – Electrocutation Hazard, Plug	1
1292990	Label – Release Brake	1
1293166	Danger, Warning – Tip-over, Crush Hazard	1
1293217	Label – Danger, Electrocutation Hazard	3
1294688	Label – Platform Overload LED Indicator Light	1
1296034	Label – Smartlink Dual Zone	2
1296301	Danger – Max. Capacity, Side Force, GS-1930/32, GS-2632, GS-3232*	1
1296306	Danger – Max. Capacity, Side Force, GS-2032*	1
1297194	Label – Outrigger Load, GS-3232*	4
1297195	Label – Transport Diagram	2
1298467	Label – Read the Manual, (panel cradle)*	2
1298467	Label – Read the Manual, (pipe cradle)*	2
1298467	Label – Read the Manual, (work tray)*	1
1298545	Danger – Tip-over, Fall, Crush Hazard, Outrigger*	1
1298834	Danger – Tip-over Hazard, Batteries	1
1305535	Label – Wheel Load, E-drive, GS-2032	4
1305536	Label – Wheel Load, E-drive, GS-2632	4
1305537	Label – Wheel Load, E-drive, GS-3232	4
T112804	Label – Ground Control Panel	1

\* These decals are model, option or configuration specific.

 Shading indicates decal is hidden from view, i.e. under covers



# Inspections

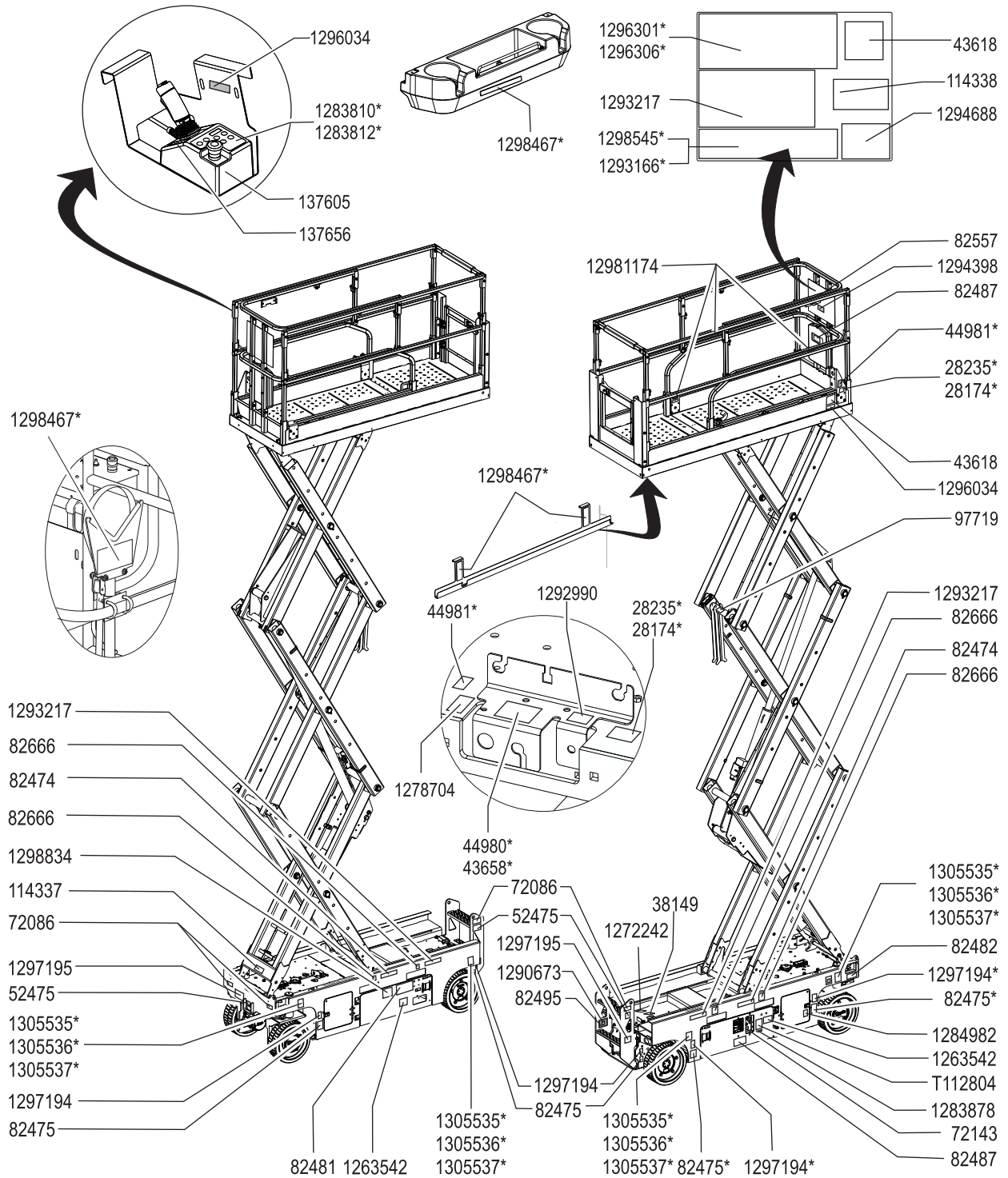

## Inspections

### Inspection for Decals with Symbols GS-2046, GS-2646, GS-3246 and GS-4046

Determine whether the decals on your machine have words or symbols. Use the appropriate inspection to verify that all decals are legible and in place.

Part No.	Decal Description	Qty
28174	Label – Power to Platform, 230V*	2
28235	Label – Power to Platform, 115V*	2
38149	Label – Patent	1
43618	Label – Directional Arrows	2
43658	Label – Power to Charger, 230V*	1
44980	Label – Power to Charger, 115V*	1
44981	Label – Air Line to Platform*	2
52475	Label – Transport Tie-down	6
72086	Label – Lifting Point	4
72143	Label – Emergency Stop	1
82474	Label – Use Safety Chock	2
82481	Label – Battery/Charger Safety	1
82487	Label – Read the Manual	2
82495	Label – Brake Release Safety and Operating Instructions	1
82666	Label - Forklift Pocket	4
97719	Label – Safety Arm	1
114337	Label – Tip-over Hazard, Limit Switch	1
114338	Label – Tip-over Hazard, Tilt Alarm	1
137605	Label – Emergency Stop, Platform Control	1
137656	Label – Drive/Steer Direction, Platform Control	1
230757	Label – Tip-over Hazard, Batteries, GS-4046*	1
1263542	Label – Compartment Access	2
1272242	Label – Machine Registration/Owner Transfer	1
1278704	Label – Battery Charger Indicator	1
1281174	Label – Lanyard Anchorage Point, Fall Arrest/Fall Restrained	5

Part No.	Decal Description	Qty
1283810	Label – Platform Control Panel	1
1283878	Label – Tech Pro Link	1
1284982	Warning – Explosion Hazard, Accumulator	1
1290673	Label – Electrocutation Hazard, Plug	1
1292052	Label – Emergency Lowering GS-1330m	1
1292990	Label – Release Brake	1
1293166	Danger, Warning – Tip-over, Crush Hazard	1
1293217	Label – Danger, Electrocutation Hazard	3
1294688	Label – Platform Overload LED Indicator Light	1
1296034	Label – Smartlink Dual Zone	2
1296312	Danger – Max. Capacity, Side Force, GS-2046*	1
1296314	Danger – Max. Capacity, Side Force, GS-2646*	1
1296316	Danger – Max. Capacity, Side Force, GS-3246*	1
1296318	Danger – Max. Capacity, Side Force, GS-4047*	1
1297195	Label – Transport Diagram, GS-2046*	2
1297196	Label – Transport and Lifting, GS-2646, GS-3246, GS-4046*	2
1298467	Label – Read the Manual, (panel cradle)*	2
1298467	Label – Read the Manual, (pipe cradle)*	2
1298467	Label – Read the Manual, (work tray)*	1
1298834	Danger – Tip-over Hazard, Batteries, GS-2046, GS-2646, GS-3246*	1
1305512	Label – Wheel Load, E-drive, GS-2046*	4
1305513	Label – Wheel Load, E-drive, GS-2646*	4
1305514	Label – Wheel Load, E-drive, GS-3246*	4
1305515	Label – Wheel Load, E-drive, GS-4046*	4
T112804	Label – Ground Control Panel	1

\* These decals are model, option or configuration specific.  Shading indicates decal is hidden from view, i.e. under covers

# Inspections

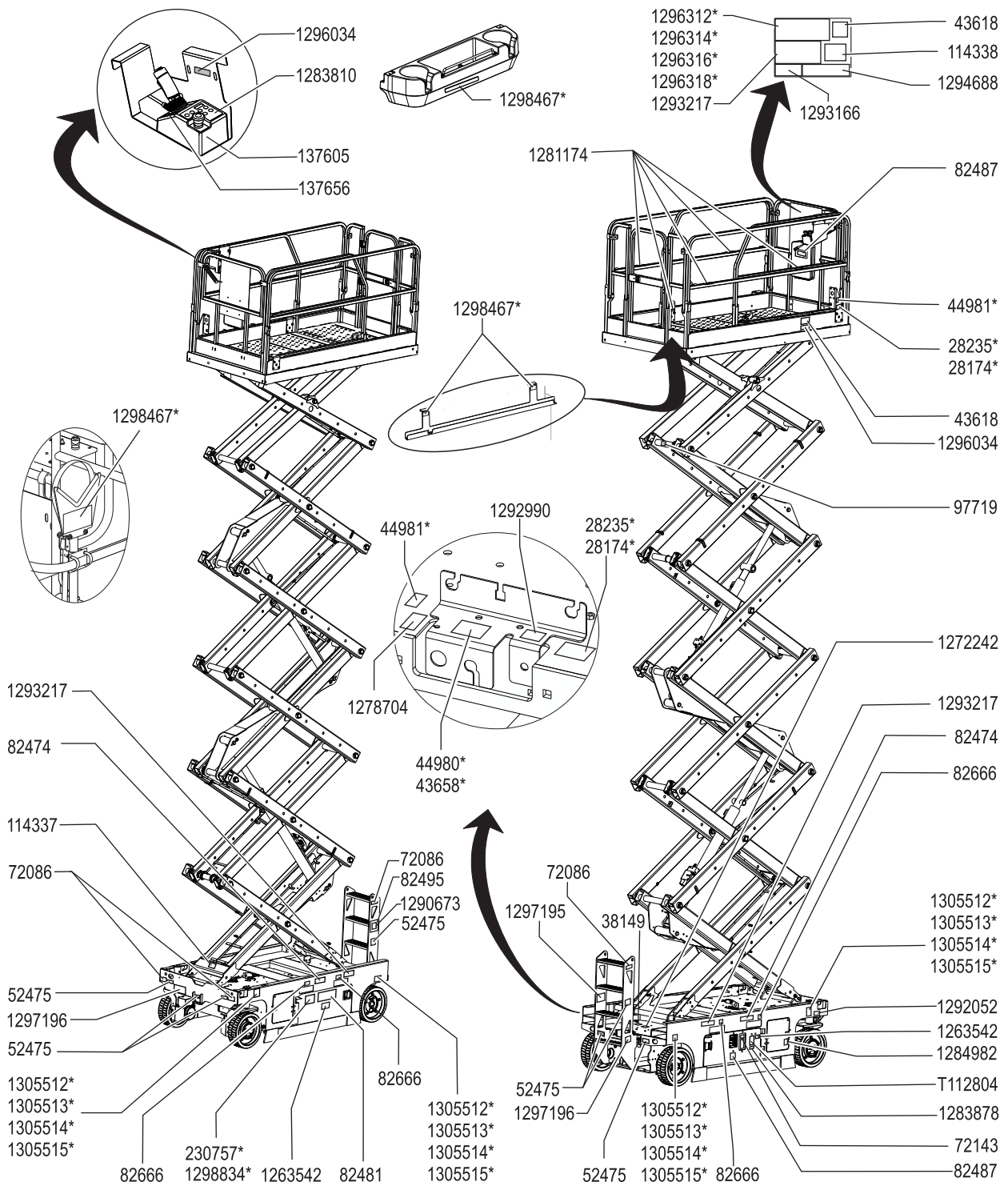

---

# Operating Instructions



---

## Do Not Operate Unless:

- You learn and practice the principles of safe machine operation contained in this operator's manual.
  - 1 Avoid hazardous situations.
  - 2 Always perform a pre-operation inspection.
  - 3 Always perform function tests prior to use.
  - 4 Inspect the workplace.
  - 5 **Only use the machine as it was intended.**

## Fundamentals

The Operating Instructions section provides instructions for each aspect of machine operation. It is the operator's responsibility to follow all the safety rules and instructions in the operator's, safety, and responsibilities manuals.

Using the machine for anything other than lifting personnel, along with their tools and materials, to an aerial work site is unsafe and dangerous.

Only trained and authorized personnel should be permitted to operate a machine. If more than one operator is expected to use a machine at different times in the same work shift, they must all be qualified operators and are all expected to follow all safety rules and instructions in the operator's, safety, and responsibilities manuals. That means every new operator should perform a pre-operation inspection, function tests, and a workplace inspection before using the machine.

# Operating Instructions

## Emergency Stop

Push in the red Emergency Stop button to the off position at the ground controls or the platform controls to stop all functions.

Repair any function that operates when either red Emergency Stop button is pushed in.

## Auxiliary Lowering

- 1 Pull the auxiliary lowering knob to lower the platform.

## Operation from Ground

- 1 Be sure the battery pack is connected before operating the machine.
- 2 Turn the key switch to ground control.
- 3 Pull out both ground and platform red Emergency Stop buttons to the on position.

## To Position Platform

- 1 At the control panel, press Enter button to cycle between indoor and outdoor area of operations.
- 2 Press and hold the lift function enable.
- 3 Press the platform up or down button.

## Operation from Platform

- 1 Be sure the battery pack is connected before operating the machine.
- 2 Turn the key switch to platform control.
- 3 Pull out both ground and platform red Emergency Stop buttons to the on position.

## To Position Platform

- 1 Press the Indoor or Outdoor use button.

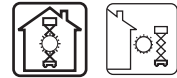

Note: If no area of operation is selected the Outdoor area of operation will automatically be selected.

- 2 Press the lift function button. On the LED screen, a circle below the lift function symbol will be displayed.



If the control handle is not moved within seven seconds of pushing the lift function button, the circle below the lift function symbol will turn off and lift function will not operate. Press the lift function button again.

- 3 Press and hold the function enable switch on the control handle.
- 4 Machines equipped with foot switch: Press and hold the foot switch and press and hold the function enable switch on the control handle at the same time.
- 5 Move the control handle in the direction indicated by the markings on the control panel.

# Operating Instructions

## To Position Outriggers (GS-3232 models)

To Extend Outriggers:

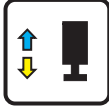
- 1 Press the outrigger function button. On the LCD screen, a circle below the outrigger function symbol will turn on. 
- 2 Machines equipped with foot switch: Press and hold the foot switch and press and hold the function enable switch on the control handle at the same time.
- 3 Move the control handle in the direction indicated by the yellow arrow.

The outriggers will begin to extend. The individual outrigger indicator light will turn solid green as the corresponding outrigger makes contact with the ground. Continue moving the control handle until the lift enable indicator light turns green and a beep is heard. The machine is now level. When the lift error indicator light turns red, the up/down and drive functions are disabled. The lift error indicator light will turn red under the following conditions:

- The platform is raised to the maximum indoor or outdoor drivable height and the outriggers are not deployed.
- Not all outriggers are in contact with the ground.
- All four outriggers are in contact with the ground but the machine is not level.
- Error code.

Note: If the outrigger enable and extend buttons are released too soon during extension, the outrigger indicator lights will continue to flash green, indicating the outriggers are not contacting the ground.

Note: If the outrigger lights are solid green, the machine may not be level or the outriggers may not be fully deployed if a long beep is not heard at the platform controls alarm.

To Retract Outriggers:

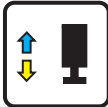
- 1 Press the outrigger function button. 
- 2 Machines equipped with foot switch: Press and hold the foot switch and press and hold the function enable switch on the control handle at the same time.
- 3 Move the control handle in the direction indicated by the blue arrow.

Release the control handle once the outriggers are off the ground. After approximately 5 seconds, the outrigger indicator lights will turn off. All functions are now restored.

Note: If the outrigger enable and retract buttons are released too soon during retraction, the outrigger indicator lights will flash green, indicating the outriggers are not fully retracted.

# Operating Instructions

## To Steer

- 1 Press the drive function button. On the LED screen, a circle below the drive function symbol will turn on.

If the control handle is not moved within seven seconds of pushing the drive function button, the circle below the drive function symbol will turn off and drive function will not operate. Press the drive function button again.

- 2 Press and hold the foot switch (if equipped).
- 3 Turn the steer wheels with the thumb rocker switch located on the top of the control handle.



## To Drive

- 1 Press the drive function button. On the LED screen, a circle below the drive function symbol will turn on.

If the control handle is not moved within seven seconds of pushing the drive function button, the circle below the drive function symbol will turn off and drive function will not operate. Press the drive function button again.

- 2 Machines equipped with foot switch: Press and hold the foot switch and press and hold the function enable switch on the control handle at the same time.

- 3 Increase speed: Slowly move the control handle off center.

Decrease speed: Slowly move the control handle toward center.

Stop: Return the control handle to center or release the function enable switch.

Use the color-coded direction arrows on the platform controls and on the platform to identify the direction the machine will travel.

Machine travel speed is restricted when the platform is raised.

Battery condition will affect machine performance. Machine drive speed and function speed will drop when the battery level indicator is flashing.



# Operating Instructions

## To select drive speed

The drive controls can operate in two different drive speed modes. When the drive speed button light is on, slow drive speed mode is active. When the button light is off, fast drive speed mode is active.

Press the drive speed button to select the desired drive speed.



Note: When the platform is elevated, the drive speed button light is always on, indicating elevated drive speed.

## ▲ Driving on a slope

Determine the slope and side slope ratings for the machine and determine the slope grade.

### Maximum slope rating, stowed position:



GS-1530, GS-1532, GS-2032, GS-2046, GS-2646, GS-2646 XH	30%	16.7°
GS-1930, GS-1932, GS-1932 XH, GS-2632, GS-3232, GS-3246, GS-3246 XH, GS-4046	25%	14°

### Maximum side slope rating, stowed position:



GS-1530, GS-2032, GS-2046, GS-2646, GS-2646 XH	30%	16.7°
GS-1930, GS-1932, GS-1932 XH, GS-2632, GS-3232, GS-3246, GS-3246 XH, GS-4046	25%	14°

Note: Slope rating is subject to ground conditions with one person in the platform and adequate traction. Additional platform weight may reduce slope rating.

## To determine the slope grade:

Measure the slope with a digital inclinometer OR use the following procedure.

You will need:

- carpenter's level
- straight piece of wood, at least 3 feet/1 m long
- tape measure

Lay the piece of wood on the slope.

At the downhill end, lay the level on the top edge of the piece of wood and lift the end until the piece of wood is level.

While holding the piece of wood level, measure the vertical distance from the bottom of the piece of wood to the ground.

Divide the tape measure distance (rise) by the length of the piece of wood (run) and multiply by 100.

Example:



Piece of wood = 144 inches (3.6 m)

Run = 144 inches (3.6 m)

Rise = 12 inches (0.3 m)

$12 \text{ in} \div 144 \text{ in} = 0.083 \times 100 = 8.3\% \text{ grade}$   
 $0.3 \text{ m} \div 3.6 \text{ m} = 0.083 \times 100 = 8.3\% \text{ grade}$

If the slope exceeds the maximum slope or side slope rating, then the machine must be winched or transported up or down the slope. See Transport and Lifting section.



# Operating Instructions

## Operational indicator codes

If the platform controls LED or ground controls LCD diagnostic readout displays an operational indicator code such as LL, the fault condition must be repaired or removed before resuming machine operation. Push in and pull out the red Emergency Stop button to reset the system.



LED Readout

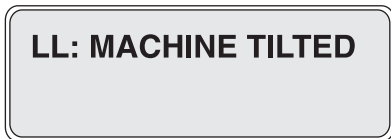

LCD Readout

### Operational Indicator Codes

Code	Condition
LL	Off-Level
OL	Platform Overloaded
CH	Chassis Mode Operation
PHS	Pothole Guard Stuck
ND	No Drive (option)
LD	Lifting Disabled (GS-3232 only)
OHL	Outdoor Height Limit

For further information, please consult the appropriate Genie Service Manual. A code and a description of a code can also be viewed at the ground controls LCD display.

## Platform Overload

If the platform controls LED diagnostic readout displays a flashing OL and the ground controls LCD diagnostic readout displays OL: Platform Overloaded, the platform is overloaded and no functions will operate. An alarm will sound.

- 1 Push in the red Emergency Stop button to the off position.
- 2 Remove weight from the platform.
- 3 Pull out the red Emergency Stop button to the on position.

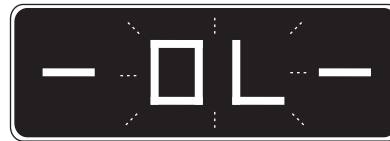

LED Readout



LCD Readout

When the platform is being raised or lowered, a self-check function will be performed near maximum height. The machine may stop and an alarm may sound. If the machine is not overloaded, normal operation will resume.

## Overload Recovery

If the ground controls LCD diagnostic readout displays Overload Recovery, the auxiliary lowering system has been used while the platform was overloaded. For information on how to reset the message, please consult the appropriate Genie Service Manual.

# Operating Instructions

## Tilt Sensor Activation Settings

Tilt Sensor Activation Settings	
Chassis Angle (side to side)	1.5°
Chassis Angle (front to back)	3°

If the tilt alarm sounds while raising the platform, lower the platform and move the machine to a firm, level surface. If the tilt alarm sounds when the platform is raised, use extreme caution to lower the platform.

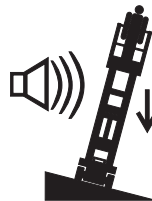

When the platform controls LED readout displays LL, the ground controls LCD displays LL: Machine Tilted, and the tilt alarm sounds at 180 beeps per minute, the following functions are affected: drive, steer, and elevate functions are disabled.

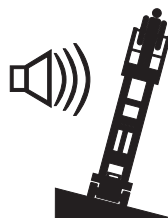

Return the machine to level ground to restore lift functions.

## Operation from Ground with Controller

Maintain safe distances between the operator, machine and fixed objects.

Be aware of the direction the machine will travel when using the controller.

## Battery Level Indicator

Use the LED diagnostic readout to determine the battery level.

Note: When a blinking LO code appears on the platform controls LED display, the machine must be taken out of service and charged, otherwise all machine functions will be disabled.



Full Charge



Half Charge



Low Charge



LO Flashing

## Operating Instructions

### How to Use the Safety Arm

- 1 Raise the platform approximately 8ft/2.4 m to 13 ft/4.0 m from the ground.
- 2 Rotate the safety arm away from the machine and let it hang down.
- 3 Lower the platform until the safety arm rests securely on the link. Keep clear of the safety arm when lowering the platform.

### How to Fold Down the Guardrails

#### **GS-1530, GS-1532, GS-1930, GS-1932, GS-2032, GS-2632 and GS-3232**

The platform railing system consists of one fold down rail section for the extension deck and one section for the main deck. All sections are held in place by four wire lock pins.

- 1 Fully lower the platform and retract the platform extension.
- 2 Remove the platform controls.
  - ▲ Fall hazard. Use caution and maintain a firm footing on the platform floor at all times while folding the guard rails.
- 3 From inside the platform, remove the two extension deck lock pins.
  - ▲ Keep hands free of pinch points.
- 4 From the middle of the extension deck railing, fold down the extension deck rail assembly toward the rear of the unit.

- 5 At the rear of the main deck, remove the two main deck lock pins.
  - ▲ Keep hands free of pinch points.
- 6 From the middle of the unit, fold down the main deck railing assembly toward the front of the unit.
- 7 Remove the lock pin from the entry swing tube. Raise and step through the entry swing tube, lower the entry swing tube, and insert the lock pin.
- 8 Carefully open the gate and exit the platform.
- 9 Insert the four lock pins back into each side rail bracket.

Note: To assist in the removal and replacement of the wire lock pins, pull or push back on the railing to compress the rubber bumpers.

---

# Operating Instructions

## GS-2046, GS-2646, GS-3246

The platform railing system consists of three fold down rail sections for the extension deck and three sections for the main deck. All six sections are held in place by four wire lock pins.

- 1 Fully lower the platform and retract the platform extension.
- 2 Remove the platform controls.
- 3 From inside the platform, remove the two front wire lock pins.
- 4 Fold down the front rail assembly. Keep hands clear of pinch points.
- 5 Replace the two removed pins back into each side rail bracket.
- 6 Fold down each side rail assembly. Keep hands clear of pinch points.
- 7 At the rear of the main deck, remove the two wire lock pins.
- 8 Carefully open the gate and move to the ground.
- 9 Fold down the rear gate and entry side rails as one unit. Keep hands clear of pinch points.
- 10 Fold down the left and right side rails. Keep hands clear of pinch points.
- 11 Replace the two removed pins back into each side rail bracket.

## How to Raise the Guardrails

Follow the fold down instructions but in reverse order, ensuring all lock pins are in place and installed properly.

## Operating Instructions

### Lift Tools Pipe Cradle Instructions

The Lift Tools Pipe Cradle assembly consists of 2 pipe cradles positioned at either side of the platform and mounted to the guardrails with U-bolts.

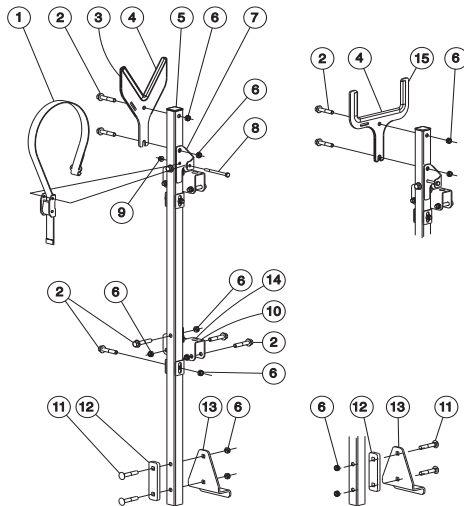

GS-1530 GS-1930  
GS-1932 GS-1932 XH  
GS-2032 GS-2632 GS-3232

GS-2046  
GS-2646 GS-2646 XH  
GS-3246 GS-3246 XH  
GS-4046

- 1 strap
- 2 bolt, 3/8-16 x 2"
- 3 cradle
- 4 edge trim
- 5 cap
- 6 nut, 3/8-16
- 7 strap brace
- 8 bolt, 1/4-20 x 3.25"
- 9 nut, 1/4-20
- 10 pin bracket
- 11 carriage bolt, 3/8-16 x 2.25"
- 12 spacer
- 13 foot mount
- 14 rubber bumper
- 15 large pipe cradle

### Observe and Obey:

- Lift Tools Pipe Cradle must be mounted on the inside of the platform.
- Lift Tools Pipe Cradles cannot be used with any other option, except Lift Tools Work Tray and Lift Guard Contact Alarm.
- Lift Tools Pipe Cradles must not obstruct the platform controls or the platform entrance.
- Lift Tools Pipe Cradle assembly is restricted to indoor use only.
- Platform is restricted to one person when Lift Tools Pipe Cradles option is in use.
- The bottom foot mount of the Lift Tools Pipe Cradles tube must rest on the platform toe-board.
- Be sure the Lift Tools Pipe Cradles is secured to the platform.

### Lift Tools Pipe Cradle Installation

- 1 Slide the railing mounting brackets until the rubber bumper lands on the railings.
- 2 Tighten the bolts on foot mount bracket.
- 3 Tighten the bolts on railing mounting brackets.

## Operating Instructions

### Lift Tools Pipe Cradle Operation

- 1 Place the load so that it rests in both Lift Tools Pipe Cradles. The length of the load should be parallel with the length of the platform and centered between the Lift Tools Pipe Cradles.
- 2 Secure the load to each Lift Tools Pipe Cradle. Pass the nylon strap over the load. Depress the buckle and slide the strap through. Tighten the strap.
- 3 Gently push and pull on the load to make sure the Lift Tools Pipe Cradles and load are secure.
- 4 Keep the load secured when the machine is moving.

The Lift Tools Pipe Cradles assembly weighs 25 lbs/11.4 kg.

---

#### Maximum Lift Tools Pipe Cradles Capacity

GS-1530, GS-1532, GS-1930, GS-1932, GS-1932 XH, GS-2032	215 lbs 97.5 kg
GS-2632, GS-3232	100 lbs 45.4 kg
GS-2046, GS-2646, GS-2646 XH	445 lbs 202.0 kg
GS-3246, GS-3246 XH, GS-4046	100 lbs 45.4 kg

- ▲ Tip-over hazard. The weight of the Lift Tools Pipe Cradle assembly and the load in the Lift Tools Pipe Cradle assembly will reduce the rated platform capacity of the machine and must be factored into the total platform load.
- ▲ Tip-over hazard. The weight of the Lift Tools Pipe Cradle assembly and the load in the Lift Tools Pipe Cradle may limit the maximum number of occupants in the platform.

Large pipe cradle capacity: 6" Maximum diameter. See load chart for weight capacity.

Do not operate unless you are adequately instructed and are aware of all hazards associated with lifting pipes.

Do not cause a horizontal force or side load to the machine by raising or lowering a fixed or overhanging load.

Do not transport the unit with Lift Tools Pipe Cradles installed. Remove entire assembly before transporting the unit.

## Operating Instructions

### Panel Carrier Instructions

The Lift Tools Panel Carrier assembly consists of a carrier assembly and a strap assembly.

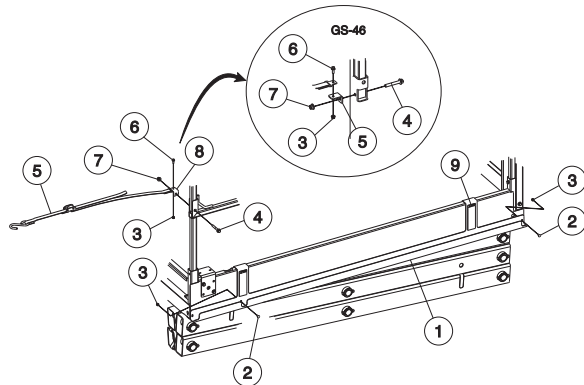

- 1 carrier
- 2 carriage bolt, 1/4-20 x 0.75"
- 3 nut, 1/4-20
- 4 bolt, 3/8-16 x 2.25"
- 5 strap
- 6 bolt, 1/4-20 x 0.75"
- 7 nut, 3/8-16
- 8 anchor, strap
- 9 decal, warning

### Observe and Obey:

- Lift Tools Panel Carrier must be mounted on the left side of the platform.
- Lift Tools Panel Carrier cannot be used with any other option, except Lift Tools Work Tray.
- Lift Tools Panel Carrier must not obstruct the platform controls or the platform entrance.
- Lift Tools Panel Carrier is restricted to indoor use only.
- The platform is restricted to one person when Lift Tools Panel Carrier option is in use.
- Be sure that the Lift Tools Panel Carrier is secured to the platform.

### Panel Carrier Installation

- 1 Hang carrier (1) onto the bottom flange of the platform, on the left side.
- 2 Secure the carrier with 2, 1/4" carriage bolts (2) and lock nuts (3).
- 3 Attach mounting tab (8) to front rail post. A 3/8" bolt (4) and nut (7) are provided.
- 4 Attach strap (5) to mounting tab.

## Operating Instructions

### Installation of Panel Carrier Strap

- 1 Open the clamp and install it on the mounting tab with the 1/4" x 0.75" bolt (6).
- 2 Install the strap assembly end plate onto the bolt.
- 3 Insert the bolt through the other side of the clamp.

### Panel Carrier Operation

- 1 Place the load so that it rests in the center of the Lift Tools Panel Carrier.
- 2 Secure the load to the platform using the strap by passing it in front of the load and securing the S-hook around the upper rail near the rear of the platform.
- 3 Gently push and pull on the load to make sure the panel carrier and load are secure.
- 4 Keep the load secured when the machine is moving.

The Lift Tools Panel Carrier assembly weighs 22 lbs/10 kg.

### Maximum Lift Tools Panel Carrier Capacity Load Chart

GS-1530, GS-1532, GS-1930, GS-1932, GS-1932 XH GS-2032, GS-2632, GS-3232	100 lbs 45.4 kg
GS-2046, GS-2646, GS-2646 XH, GS-3246, GS-3246 XH, GS-4046	200 lbs 90.7 kg

- ▲ Tip-over hazard. The weight of the Lift Tools Panel Carrier assembly and the load in the Lift Tools Panel Carrier assembly will reduce the rated platform capacity of the machine and must be factored into the total platform load.
- ▲ Tip-over hazard. The weight of the Lift Tools Panel Carrier assembly and the load in the Lift Tools Panel Carrier may limit the maximum number of occupants in the platform.
- ▲ Maximum panel size allowed: 4 feet high x 8 feet long. See load chart for weight capacity.

Do not operate unless you are adequately instructed and are aware of all hazards associated with lifting panels.

Do not cause a horizontal force or side load to machine by raising or lowering a fixed or overhanging load.

Do not transport the unit with Lift Tools Panel Carrier installed. Remove entire assembly before transporting the unit.



## Operating Instructions

### Lift Tools Work Tray Instructions

The Lift Tools Work Tray assembly consists of one tray and two mounting brackets with hardware.

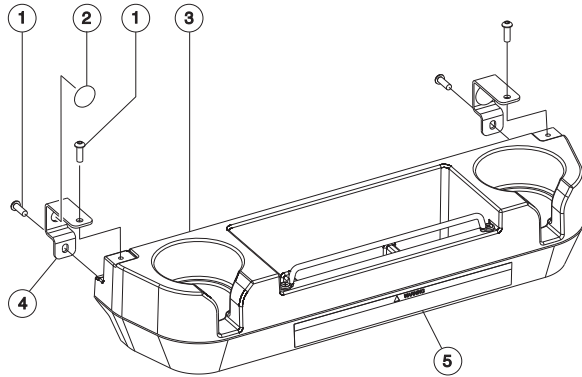

- 1 bolt, 1/4-20 x 0.75"
- 2 rubber bumper
- 3 lift tool work tray
- 4 tool tray bracket
- 5 decal, warning

### Observe and Obey: Lift Tools Work Tray Installation

- Lift Tools Work Tray must be installed on the inside of the platform.
- Only one Lift Tools Work Tray can be used per machine.
- GS-1530, GS-1532, GS-1930, GS-1932, GS-1932 XH: mount Lift Tools Work Tray on the Extension Deck rail on the opposite side of the PCON.
- GS-2032, GS-2632, GS-3232, GS-2046, GS-2646, GS-2646 XH, GS-3246, GS-3246 XH, GS-4046: mount Lift Tools Work Tray on the extension deck rail opposite the PCON or on main deck rail behind the extension deck when retracted on either side of machine.
- Lift Tools Work Tray can be on either upper or lower rail.
- Be sure the Lift Tools Work Tray is secured to the platform.
- Lift Tools Work Tray lanyard is for tools only. Do not attach personal safety lanyard.

### Lift Tools Work Tray Installation

- 1 Tighten the four 1/4-20 x 0.75 bolts (1).

---

# Operating Instructions

## Lift Tools Work Tray Operation

- 1 Place the load so that it rests inside the Lift Tools Work Tray.

The Lift Tools Work Tray assembly weighs 4 lbs/1.8 kg.

Maximum capacity of Lift Tools Work Tray is 50 lbs/23 kg.

- ▲ Tip-over hazard. The weight of Lift Tools Work Tray assembly and the load in the Lift Tools Work Tray assembly will reduce the rated platform capacity of the machine and must be factored into the total platform load.

## Platform Height Restriction Instructions

Platform Height Restriction allows the platform to be limited to a specific height.

## Observe and Obey: Platform Height Restriction

- Read, understand and obey all warnings and instructions provided with the Platform Height Restriction.

# Operating Instructions

## Platform Height Restriction Operation

### To limit height:

Note: The User Max Height option must be turned on. See Service and Repair manual.

- 1 Raise the platform to the desired maximum height with the platform control.
- 2 Press and hold the lift function selection button on the platform control for 5 seconds.
- 3 The maximum platform height limit is activated when:
  - a The platform control LED displays "LoHt", and
  - b The alarm beeps 7 times.
- 4 Perform function tests prior to use.

### To remove the height limit:

- 1 Turn the key switch to platform control.
- 2 Pull out the red Emergency Stop button to the on position at the ground controls.
- 3 Pull out the red Emergency Stop button to the on position at the platform controls.
- 4 Press and hold the lift function selection button for 5 seconds, at any height.
- 5 The maximum platform height limit has been removed when:
  - a The platform control LED displays "FLHt", and
  - b The alarm beeps 7 times.

### To test the platform height restriction:

- 1 Press and hold the lift function enable button, and press the platform up button.
  - ⊙ Result: The platform should raise to the previously set height. After reaching the maximum height restriction, platform movement will stop. If the operator continues holding the joystick in the elevate direction for more than 2 seconds after reaching the maximum platform height limit, the platform alarm will beep for one second and LoHt is displayed on the platform controls LED.

Note: The User Max Height option must be turned on and a height must have previously been set.

# Operating Instructions



## Battery and Charger Instructions

### Observe and Obey:

- Do not use an external charger or booster battery.
- Charge the battery in a well-ventilated area.
- Use proper AC input voltage for charging as indicated on the charger.
- Use only a Genie authorized battery and charger.

### To Charge Battery

- 1 Be sure the batteries are connected before charging the batteries.
- 2 Open the battery compartment. The compartment should remain open for the entire charging cycle.

### Maintenance-free batteries

- 1 Connect the battery charger to a grounded AC circuit.
- 2 The charger will indicate when the battery is fully charged.

### Standard Batteries

- 1 Remove the battery vent caps and check the battery acid level. If necessary, add only enough distilled water to cover the plates. Do not overfill prior to the charge cycle.
- 2 Replace the battery vent caps.
- 3 Connect the battery charger to a grounded AC circuit.
- 4 The charger will indicate when the battery is fully charged.
- 5 Check the battery acid level when the charging cycle is complete. Replenish with distilled water to the bottom of the fill tube. Do not overfill.

### After Each Use

- 1 Select a safe parking location—firm level surface, clear of obstruction and traffic.
- 2 Lower the platform.
- 3 Turn the key switch to the off position and remove the key to secure from unauthorized use.
- 4 Charge the batteries.

## Transport and Lifting Instructions





### Observe and Obey:



- ☑ Genie provides this securement information as a recommendation. Drivers are solely responsible for making sure machines are properly secured and the correct trailer is selected pursuant to US Department of Transportation regulations, other localized regulations, and their company policy.
  - ☑ Genie customers needing to containerize any lift or Genie product should source a qualified freight forwarder with expertise in preparing, loading and securing construction and lifting equipment for international shipment.
  - ☑ Only qualified mobile elevating work platform operators should move the machine on or off the truck.
  - ☑ The transport vehicle must be parked on a level surface.
  - ☑ The transport vehicle must be secured to prevent rolling while the machine is being loaded.
  - ☑ Be sure the vehicle capacity, loading surfaces and chains or straps are sufficient to withstand the machine weight. Genie lifts are very heavy relative to their size. See the serial label for the machine weight.
- ☑ The machine must be on a level surface or secured before releasing the brakes.
  - ☑ Do not allow the rails to fall when the snap pins are removed. Maintain a firm grasp on the rails when the rails are lowered.
  - ☑ Do not drive the machine on a slope that exceeds the uphill, downhill or side slope rating. See Driving on a Slope in the Operating Instructions section.
  - ☑ If the slope of the transport vehicle bed exceeds the uphill or downhill maximum slope rating, the machine must be loaded and unloaded using a winch or forklift as described in the brake release operation. See the Specifications section for the slope ratings.

## Transport and Lifting Instructions

### Brake Release Operation, Hydraulic Drive Option

- 1 Chock the wheels to prevent the machine from rolling. 
- 2 Be sure the winch line is properly secured to the drive chassis tie points and the path is clear of all obstructions.
- 3 Push in the black brake release knob to open the brake valve. 
- 4 Pump the red brake release pump knob.

### Brake Release Operation, E-Drive Option

- 1 Chock the wheels or tracks to prevent the machine from rolling. 
- 2 Be sure the winch line is properly secured to the drive chassis tie points and the path is clear of all obstructions.
- 3 Pull out the red Emergency Stop button at both the ground and platform controls and position the key switch to ground mode.
- 4 Locate the brake release toggle switch at the rear of unit.
- 5 Remove the protective cover from the toggle switch. 
- 6 Move the toggle switch as indicated in the image to engage the brake release. The alarm will turn on when the brakes are released.

After the machine is loaded:

- 1 Chock the wheels to prevent the machine from rolling.
- 2 Pull out the red Emergency Stop button at both the ground and platform controls to the on position.
- 3 Press and hold the drive/steer function enable switch on the control handle. Move the control handle off center and immediately release it to reset the brakes.
- 4 Push the red Emergency stop button at both the ground and platform controls to the off position.

Towing the Genie GS-1530, GS-1532, GS-1930, GS-1932, GS-1932 XH, GS-2032, GS-2632, GS-3232, GS-2046, GS-2646, GS-2646 XH, GS-3246, GS-3246 XH, and the GS-4046 is not recommended. If the machine must be towed, do not exceed 2 mph / 3.2 km/h.

# Transport and Lifting Instructions

## Securing to Truck or Trailer for Transit

Always use the extension deck lock when the machine is transported.

Turn the key switch to the off position and remove the key before transporting.

Inspect the entire machine for loose or unsecured items.

Use chains or straps of ample load capacity.

Use a minimum of 2 chains or straps.

Adjust the rigging to prevent damage to the chains.

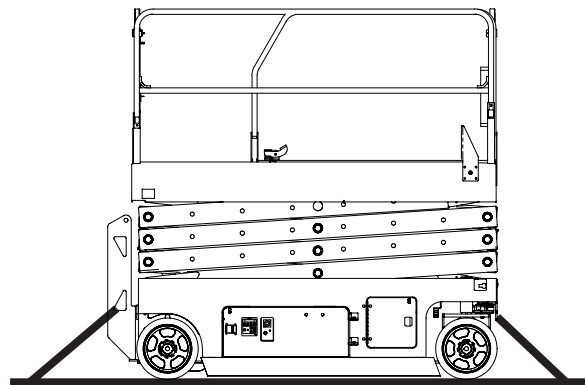
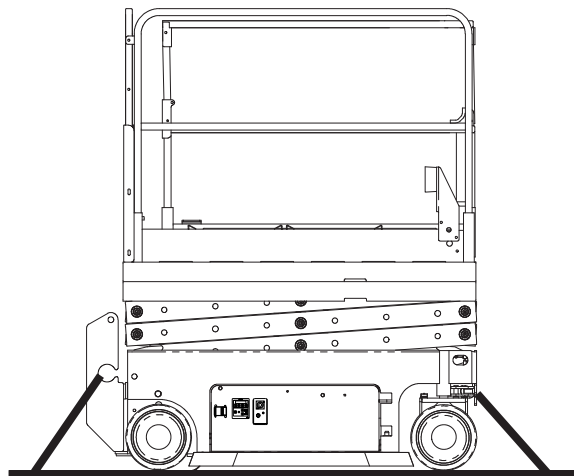
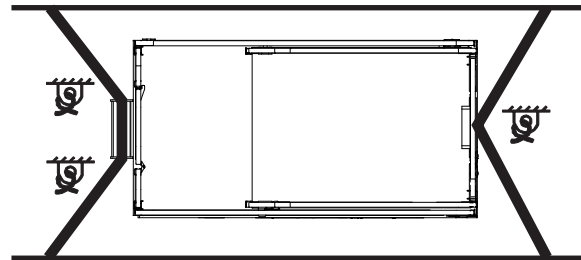
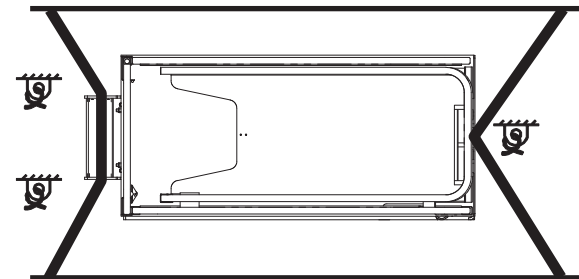

GS-1530  
GS-1532

GS-1930  
GS-1932  
GS-1932 XH

GS-2032  
GS-2632  
GS-3232

GS-2046  
GS-2646  
GS-2646 XH

GS-3246  
GS-3246 XH  
GS-4046

## Transport and Lifting Instructions



### Observe and Obey:

- ☑ Only qualified riggers should rig and lift the machine.
- ☑ Only qualified forklift operators should lift the machine with a forklift.
- ☑ Be sure the crane capacity, loading surfaces and straps or lines are sufficient to withstand the machine weight. See the serial label for the machine weight.

### Lifting the Machine with a Forklift

Be sure the extension deck, controls and component trays are secure. Remove all loose items on the machine.

Fully lower the platform. The platform must remain lowered during all loading and transport procedures.

Use the forklift pockets from the rear of the machine (both sides of the ladder) or from either side of the machine.

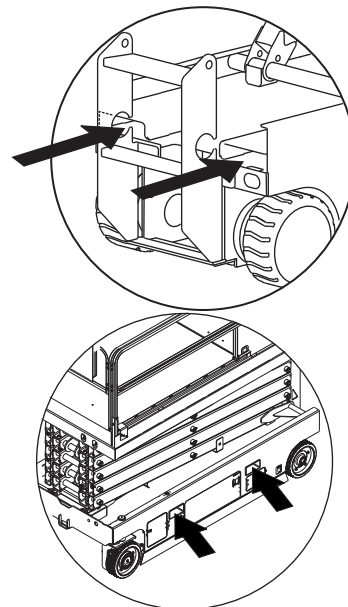

Position the forklift forks in position with the forklift pockets.

Drive forward to the full extent of the forks.

Raise the machine 16 in / 0.4 m and then tilt the forks back slightly to keep the machine secure.

Be sure the machine is level when lowering the forks.

#### **NOTICE**

Lifting the machine from the bottom can result in component damage.



---

## Transport and Lifting Instructions

### Lifting Instructions, GS-30

Fully lower the platform. Be sure the extension deck, controls and component trays are secure. Remove all loose items on the machine.

Determine the center of gravity of your machine using the table and the picture on this page.

Attach the rigging only to the designated lifting points on the machine. There are two 2.5 cm holes on the front of the machine and two holes in the ladder for lifting.

Adjust the rigging to prevent damage to the machine and to keep the machine level.

Center of Gravity Table (Actual dimensions may vary due to machine configuration, options, and manufacturing tolerances)

# Maintenance



## Observe and Obey:

- ☑ Only routine maintenance items specified in this manual shall be performed by the operator.
- ☑ Scheduled maintenance inspections shall be completed by qualified service technicians, according to the manufacturer's specifications and the requirements specified in the responsibilities manual.
- ☑ Use only Genie approved replacement parts.

## Maintenance Symbols Legend

The following symbols have been used in this manual to help communicate the intent of the instructions. When one or more of the symbols appear at the beginning of a maintenance procedure, it conveys the meaning below.



Indicates that tools will be required to perform this procedure.



Indicates that new parts will be required to perform this procedure.

## Check the Hydraulic Oil Level



Maintaining the hydraulic oil at the proper level is essential to machine operation. Improper hydraulic oil levels can damage hydraulic components. Daily checks allow the inspector to identify changes in oil level that might indicate the presence of hydraulic system problems.

- 1 Be sure that the machine is on a firm, level surface, free of obstructions, with the platform in the stowed position.
- 2 Visually inspect the oil level in the hydraulic oil tank.
- ☉ Result: The hydraulic oil level should be between the ADD and FULL marks on the tank.
- 3 Add oil as needed. Do not overfill.

---

### Hydraulic oil specifications

---

Hydraulic oil type	Chevron Rando HD equivalent
--------------------	-----------------------------

Note: For cold weather operation and information on alternative hydraulic fluids, please refer to the Genie Scissor Maintenance Manual.

# Maintenance

## Check the Batteries



Proper battery condition is essential to good machine performance and operational safety. Improper fluid levels or damaged cables and connections can result in component damage and hazardous conditions.

- ▲ **Electrocution hazard.** Contact with hot or live circuits may result in death or serious injury. Remove all rings, watches and other jewelry.
- ▲ **Bodily injury hazard.** Batteries contain acid. Avoid spilling or contacting battery acid. Neutralize battery acid spills with baking soda and water.

Note: Perform this test after fully charging the batteries.

- 1 Put on protective clothing and eye wear.
- 2 Be sure that the battery cable connections are tight and free of corrosion.
- 3 Be sure that the battery hold-down brackets are in place and secure.

Note: Adding terminal protectors and a corrosion preventative sealant will help eliminate the corrosion on the battery terminals and cables.

## Scheduled Maintenance

Maintenance performed quarterly, annually and every two years must be completed by a person trained and qualified to perform maintenance on this machine according to the procedures found in the service manual for this machine.

Machines that have been out of service for more than three months must receive the quarterly inspection before they are put back into service.

# Specifications

Model	GS-1530	
Height, working outdoor	18 ft 8 in	5.86 m
Height, platform outdoor	12 ft 8 in	3.86 m
Height, working indoor	21 ft 1 in	6.61 m
Height, platform indoor	15 ft 1 in	4.61 m
Height, stowed maximum, rails up	6 ft 11 in	2.12 m
Height, stowed maximum, rails folded	5 ft 9 in	1.76 m
Platform height, stowed maximum	3 ft 4 in	1.01 m
Height, guard rails	3 ft 7 in	1.10 m
Width	30.2 in	0.77 m
Length, stowed	6 ft 0 in	1.83 m
Length, platform extended	8 ft 11 in	2.72 m
Platform extension length	35.7 in	0.91 m
Platform dimensions (length x width)	5 ft 5 in x 29.9 in	1.66 m x 0.76 m
Maximum load capacity	600 lbs	272 kg
Maximum wind speed, outdoors	28 mph	12.5 m/s
Maximum wind speed, indoors	0 mph	0 m/s
Wheelbase	4 ft 4 in	1.32 m
Turning radius (outside)	5 ft 1 in	1.55 m
Turning radius (inside)	0 in	0 cm
Ground clearance	3.2 in	8 cm
Ground clearance Pothole guards deployed	0.9 in	2.3 cm
Weight	2739 lbs	1242 kg
(Machine weights vary with option configurations. See serial label for specific machine weight.)		
Power source	4 Batteries, 6V 210AH	
System voltage	24V	
Hydraulic pressure, maximum (E-drive)	2700 psi	186 bar
Hydraulic pressure, maximum (Hydraulic-drive)	3700 psi	255 bar
Tire size	12 x 4.5 in 31 x 11 cm	
Total vibration value to which the hand/arm system is subjected does not exceed 2.5 m/s <sup>2</sup> .		
Highest root mean square value of weighted acceleration to which the whole body is subjected does not exceed 1.6 ft/s <sup>2</sup> or 0.5 m/s <sup>2</sup> .		

## Operating temperature

Minimum	-20°F	-29°C
Maximum	120°F	48.9°C

## Airborne noise emissions

Sound pressure level at ground workstation	<70 dBA
Sound pressure level at platform workstation	<70 dBA

**Maximum slope rating, stowed position** 30% (16.7°)

**Maximum side slope rating, stowed position** 30% (16.7°)

Note: Slope rating is subject to ground conditions with one person in the platform and adequate traction. Additional platform weight may reduce slope rating.

## Drive speeds

Stowed, maximum	2.5 mph	4.0 km/h
Platform raised, maximum	0.5 mph	0.8 km/h
	40 ft/55 sec	12.2 m/55 sec

## Floor loading information, GS-1530

Tire load maximum	1370 lbs	621 kg
Tire contact pressure	152.2 psi	10.70 kg/cm <sup>2</sup> 1049 kPa
Occupied floor pressure	269 psf	1313 kg/m <sup>2</sup> 12.88 kPa

Note: Floor loading information is approximate and does not incorporate different option configurations. It should be used only with adequate safety factors.

Continuous improvement of our products is a Genie policy. Product specifications are subject to change without notice or obligation.

# Specifications

Model	GS-1532	
Height, working outdoor	18 ft 8 in	5.86 m
Height, platform outdoor	12 ft 8 in	3.86 m
Height, working indoor	21 ft 1 in	6.61 m
Height, platform indoor	15 ft 1 in	4.61 m
Height, stowed maximum, rails up	6 ft 11 in	2.12 m
Height, stowed maximum, rails folded	5 ft 9 in	1.76 m
Platform height, stowed maximum	3 ft 4 in	1.01 m
Height, guard rails	3 ft 7 in	1.10 m
Width	32.2 in	81.8 cm
Length, stowed	6 ft 0 in	1.83 m
Length, platform extended	8 ft 11 in	2.72 m
Platform extension length	35.7 in	0.91 m
Platform dimensions (length x width)	5 ft 5 in x 29.9 in	1.66 m x 0.76 m
Maximum load capacity	600 lbs	272 kg
Maximum wind speed, outdoors	28 mph	12.5 m/s
Maximum wind speed, indoors	0 mph	0 m/s
Wheelbase	4 ft 4 in	1.32 m
Turning radius (outside)	5 ft 1 in	1.55 m
Turning radius (inside)	0 in	0 cm
Ground clearance	3.2 in	8 cm
Ground clearance Pothole guards deployed	0.9 in	2.3 cm
Weight	2761 lbs	1252 kg
(Machine weights vary with option configurations. See serial label for specific machine weight.)		
Power source	4 Batteries, 6V 210AH	
System voltage	24V	
Hydraulic pressure, maximum (E-drive)	2700 psi	186 bar
Hydraulic pressure, maximum (Hydraulic-drive)	3700 psi	255 bar
Tire size	12 x 4.5 in	31 x 11 cm
Total vibration value to which the hand/arm system is subjected does not exceed 2.5 m/s <sup>2</sup> .		
Highest root mean square value of weighted acceleration to which the whole body is subjected does not exceed 1.6 ft/s <sup>2</sup> or 0.5 m/s <sup>2</sup> .		

## Operating temperature

Minimum	-20°F	-29°C
Maximum	120°F	48.9°C

## Airborne noise emissions

Sound pressure level at ground workstation	<70 dBA
Sound pressure level at platform workstation	<70 dBA

**Maximum slope rating, stowed position** 30% (16.7°)

**Maximum side slope rating, stowed position** 30% (16.7°)

Note: Slope rating is subject to ground conditions with one person in the platform and adequate traction. Additional platform weight may reduce slope rating.

## Drive speeds

Stowed, maximum	2.5 mph	4.0 km/h
Platform raised, maximum	0.5 mph	0.8 km/h
	40 ft/55 sec	12.2 m/55 sec

## Floor loading information, GS-1530

Tire load maximum	1370 lbs	621 kg
Tire contact pressure	152.2 psi	10.70 kg/cm <sup>2</sup> 1049 kPa
Occupied floor pressure	254 psf	1240 kg/m <sup>2</sup> 12.16 kPa

Note: Floor loading information is approximate and does not incorporate different option configurations. It should be used only with adequate safety factors.

Continuous improvement of our products is a Genie policy. Product specifications are subject to change without notice or obligation.

# Specifications

Model	GS-1930	
Height, working outdoor	20 ft 8 in	6.30 m
Height, platform outdoor	14 ft 8 in	4.47 m
Height, working indoor	25 ft 3 in	7.85 m
Height, platform indoor	19 ft 3 in	5.85 m
Height, stowed maximum, rails up	7 ft 1 in	2.16 m
Height, stowed maximum, rails folded	5 ft 11 in	1.80 m
Platform height, stowed maximum	3 ft 5 in	1.04 m
Height, guard rails	3 ft 7 in	1.10 m
Width	30.2 in	0.77 m
Length, stowed	6 ft 0 in	1.83 m
Length, platform extended	8 ft 11 in	2.72 m
Platform extension length	35.7 in	0.91 m
Platform dimensions (length x width)	5 ft 5 in x 29.9 in	1.66 x 0.76 m
Maximum load capacity	500 lbs	227 kg
Maximum wind speed, outdoors	28 mph	12.5 m/s
Maximum wind speed, indoors	0 mph	0 m/s
Wheelbase	4 ft 4 in	1.32 m
Turning radius (outside)	5 ft 1 in	1.55 m
Turning radius (inside)	0 in	0 cm
Ground clearance	3.2 in	8 cm
Ground clearance Pothole guards deployed	0.9 in	2.3 cm
Weight	3209 lbs	1456 kg
(Machine weights vary with option configurations. See serial label for specific machine weight.)		
Power source	4 Batteries, 6V 210AH	
System voltage	24V	
Hydraulic pressure, maximum (E-drive)	3500 psi	241 bar
Hydraulic pressure, maximum (Hydraulic-drive)	3700 psi	255 bar
Tire size	12 x 4.5 in	31 x 11 cm

Total vibration value to which the hand/arm system is subjected does not exceed 2.5 m/s<sup>2</sup>.

Highest root mean square value of weighted acceleration to which the whole body is subjected does not exceed 1.6 ft/s<sup>2</sup> or 0.5 m/s<sup>2</sup>.

## Operating temperature

Minimum	-20°F	-29°C
Maximum	120°F	48.9°C

## Airborne noise emissions

Sound pressure level at ground workstation	<70 dBA
Sound pressure level at platform workstation	<70 dBA

**Maximum slope rating, stowed position** 25% (14°)

**Maximum side slope rating, stowed position** 25% (14°)

Note: Slope rating is subject to ground conditions with one person in the platform and adequate traction. Additional platform weight may reduce slope rating.

## Drive speeds

Stowed, maximum	2.5 mph	4.0 km/h
Platform raised, maximum	0.5 mph	0.8 km/h
	40 ft/55 sec	12.2 m/55 sec

## Floor loading information, GS-1930

Tire load maximum	1483 lbs	672 kg
Tire contact pressure	164.7 psi	11.58 kg/cm <sup>2</sup> 1136kPa
Occupied floor pressure	287 psf	1400 kg/m <sup>2</sup> 13.73 kPa

Note: Floor loading information is approximate and does not incorporate different option configurations. It should be used only with adequate safety factors.

Continuous improvement of our products is a Genie policy. Product specifications are subject to change without notice or obligation.

# Specifications

Model	GS-1932	
Height, working outdoor, dual zone	20 ft 8 in	6.30 m
Height, platform outdoor, dual zone	14 ft 8 in	4.47 m
Height, working outdoor, XH	25 ft 3 in	7.85 m
Height, platform outdoor, XH	19 ft 3 in	5.85 m
Height, working indoor, dual zone/XH	25 ft 3 in	7.85 m
Height, platform indoor, dual zone/XH	19 ft 3 in	5.85 m
Height, platform outdoor	14 ft 8 in	4.47 m
Height, working indoor	25 ft 3 in	7.85 m
Height, platform indoor	19 ft 3 in	5.85 m
Height, stowed maximum, rails up	7 ft 1 in	2.16 m
Height, stowed maximum, rails folded	5 ft 11 in	1.8 m
Platform height, stowed maximum	3 ft 5 in	1.04 m
Height, guard rails	3 ft 7 in	1.10 m
Width	32.2 in	0.82 m
Length, stowed	6 ft 0 in	1.83 m
Length, platform extended	8 ft 11 in	2.72 m
Platform extension length	35.7 in	0.91 m
Platform dimensions (length x width)	5 ft 5 in x 29.9 in	1.66 x 0.76 m
Maximum load capacity	500 lbs	227 kg
Maximum wind speed, outdoors	28 mph	12.5 m/s
Maximum wind speed, indoors	0 mph	0 m/s
Wheelbase	4 ft 4 in	1.32 m
Turning radius (outside)	5 ft 1 in	1.55 m
Turning radius (inside)	0 in	0 cm
Ground clearance	3.2 in	8 cm
Ground clearance Pothole guards deployed	0.9 in	2.3 cm
Weight, dual zone	2929 lbs	1329 kg
Weight, XH	3429 lbs	1555 kg
(Machine weights vary with option configurations. See serial label for specific machine weight.)		
Power source	4 Batteries, 6V 210AH	
System voltage	24V	
Hydraulic pressure, maximum (E-drive)	3500 psi	241 bar
Hydraulic pressure, maximum (Hydraulic-drive)	3700 psi	255 bar
Tire size	12 x 4.5 in	31 x 11 cm

Total vibration value to which the hand/arm system is subjected does not exceed 2.5 m/s<sup>2</sup>.

Highest root mean square value of weighted acceleration to which the whole body is subjected does not exceed 1.6 ft/s<sup>2</sup> or 0.5 m/s<sup>2</sup>.

### Operating temperature

Minimum	-20°F	-29°C
Maximum	120°F	48.9°C

### Airborne noise emissions

Sound pressure level at ground workstation	<70 dBA
Sound pressure level at platform workstation	<70 dBA

**Maximum slope rating, stowed position** 25% (14°)

**Maximum side slope rating, stowed position** 25% (14°)

Note: Slope rating is subject to ground conditions with one person in the platform and adequate traction. Additional platform weight may reduce slope rating.

### Drive speeds

Stowed, maximum	2.5 mph	4.0 km/h
Platform raised, maximum	0.5 mph	0.8 km/h
	40 ft/55 sec	12.2 m/55 sec

### Floor loading information, GS-1932

Tire load maximum, dual zone	1473 lbs	668 kg
Tire load maximum, XH	1712 lbs	776 kg
Tire contact pressure, dual zone	163.3 psi	11.50 kg/cm <sup>2</sup> 1128 kPa
Tire contact pressure, XH	190.2 psi	13.37 kg/cm <sup>2</sup> 1311 kPa
Occupied floor pressure, dual zone	258 psf	1262 kg/m <sup>2</sup> 12.38 kPa
Occupied floor pressure, XH	294 psf	1435 kg/m <sup>2</sup> 14.07 kPa

Note: Floor loading information is approximate and does not incorporate different option configurations. It should be used only with adequate safety factors.

Continuous improvement of our products is a Genie policy. Product specifications are subject to change without notice or obligation.

# Specifications

Model	GS-2032	
Height, working outdoor	22 ft	6.88 m
Height, platform outdoor	16 ft	4.88 m
Height, working indoor	26 ft 1 in	8.13 m
Height, platform indoor	20 ft 1 in	6.13 m
Height, stowed maximum, rails up	7 ft 2 in	2.17 m
Height, stowed maximum, rails folded	5 ft 11 in	1.80 m
Platform height, stowed maximum	3 ft 6 in	1.07 m
Height, guard rails	3 ft 7 in	1.10 m
Width	32.2 in	0.82 m
Length, stowed	8 ft 0 in	2.44 m
Length, platform extended	10ft 11 in	3.33 m
Platform extension length	35.8 in	0.91 m
Platform dimensions (length x width)	7 ft 5 in x 32.9 in	2.27m x 0.84 m
Maximum load capacity	800 lbs	363 kg
Maximum wind speed, outdoors	28 mph	12.5 m/s
Maximum wind speed, indoors	0 mph	0 m/s
Wheelbase	6 ft 1 in	1.85 m
Turning radius (outside)	7 ft 0 in	2.1 m
Turning radius (inside)	0 in	0 cm
Ground clearance	5 in	12 cm
Ground clearance Pothole guards deployed	0.9 in	2.3 cm
Weight	4038 lbs	1832 kg
(Machine weights vary with option configurations. See serial label for specific machine weight.)		
Power source	4 Batteries, 6V 210AH	
System voltage	24V	
Hydraulic pressure, maximum (E-drive)	2400 psi	165 bar
Hydraulic pressure, maximum (Hydraulic-drive)	3500 psi	241 bar
Tire size	15 x 5 in	38 x 13 cm

Total vibration value to which the hand/arm system is subjected does not exceed 2.5 m/s<sup>2</sup>.

Highest root mean square value of weighted acceleration to which the whole body is subjected does not exceed 1.6 ft/s<sup>2</sup> or 0.5 m/s<sup>2</sup>.

## Operating temperature

Minimum	-20°F	-29°C
Maximum	120°F	48.9°C

## Airborne noise emissions

Sound pressure level at ground workstation	<70 dBA
Sound pressure level at platform workstation	<70 dBA

**Maximum slope rating, stowed position** 30% (16.7°)

**Maximum side slope rating, stowed position** 30% (16.7°)

Note: Slope rating is subject to ground conditions with one person in the platform and adequate traction. Additional platform weight may reduce slope rating.

## Drive speeds

Stowed, maximum, hydraulic drive	2.0 mph	3.2 km/h
Stowed, maximum, E-drive	2.5 mph	4.0 km/h
Platform raised, maximum	0.5 mph 40 ft/55 sec	0.8 km/h 12.2m/55sec

## Floor loading information, GS-2032

Tire load maximum	1653 lbs	750 kg
Tire contact pressure	108.5 psi 15622 psf	7.63 kg/cm <sup>2</sup> 748 kPa
Occupied floor pressure	256 psf	1250 kg/m <sup>2</sup> 12.26 kPa

Note: Floor loading information is approximate and does not incorporate different option configurations. It should be used only with adequate safety factors.

Continuous improvement of our products is a Genie policy. Product specifications are subject to change without notice or obligation.



# Specifications

Model	GS-2632	
Height, working outdoor	25 ft	7.79 m
Height, platform outdoor	19 ft	5.79 m
Height, working indoor	32 ft 1 in	9.96 m
Height, platform indoor	26 ft 1 in	7.96 m
Height, stowed maximum, rails up	7 ft 7 in	2.32 m
Height, stowed maximum, rails folded	6 ft 4 in	1.94 m
Platform height, stowed maximum	3 ft 11 in	1.20 m
Height, guard rails	3 ft 7 in	1.10 m
Width	32.2 in	0.82 m
Length, stowed	8 ft 0 in	2.44 m
Length, platform extended	10 ft 11 in	3.33 m
Platform extension length	35.8 in	0.91 m
Platform dimensions (length x width)	7 ft 5 in x 32.9 in	2.27 x 0.84 m
Maximum load capacity	500 lbs	227 kg
Maximum wind speed, outdoors	28 mph	12.5 m/s
Maximum wind speed, indoors	0 mph	0 m/s
Wheelbase	6 ft 1 in	185 cm
Turning radius (outside)	7 ft 0 in	2.1 m
Turning radius (inside)	0 in	0 cm
Ground clearance	5 in	12 cm
Ground clearance Pothole guards deployed	0.9 in	2.3 cm
Weight	4729 lbs	2145 kg
(Machine weights vary with option configurations. See serial label for specific machine weight.)		
Power source	4 Batteries, 6V 210AH	
System voltage	24V	
Hydraulic pressure, maximum (E-drive)	2100 psi	145 bar
Hydraulic pressure, maximum (Hydraulic-drive)	3500 psi	241 bar
Tire size	15 x 5 in	38 x 13 cm
Total vibration value to which the hand/arm system is subjected does not exceed 2.5 m/s <sup>2</sup> .		
Highest root mean square value of weighted acceleration to which the whole body is subjected does not exceed 1.6 ft/s <sup>2</sup> or 0.5 m/s <sup>2</sup> .		

## Operating temperature

Minimum	-20°F	-29°C
Maximum	120°F	48.9°C

## Airborne noise emissions

Sound pressure level at ground workstation	<70 dBA
Sound pressure level at platform workstation	<70 dBA

**Maximum slope rating, stowed position** 25% (14°)

**Maximum side slope rating, stowed position** 25% (14°)

Note: Slope rating is subject to ground conditions with one person in the platform and adequate traction. Additional platform weight may reduce slope rating.

## Drive speeds

Stowed, maximum, hydraulic drive	2.0 mph	3.2 km/h
Stowed, maximum, E-drive	2.5 mph	4.0 km/h
Platform raised, maximum	0.5 mph 40 ft/55 sec	0.8 km/h 12.2m/55 sec

## Floor loading information, GS-2632

Tire load maximum	1765 lbs	801 kg
Tire contact pressure	115.8 psi 16680 psf	8.14 kg/cm <sup>2</sup> 799 kPa
Occupied floor pressure	274 psf	1340 kg/m <sup>2</sup> 13.14 kPa

Note: Floor loading information is approximate and does not incorporate different option configurations. It should be used only with adequate safety factors.

Continuous improvement of our products is a Genie policy. Product specifications are subject to change without notice or obligation.

# Specifications

Model	GS-3232	
Height, working outdoor on outriggers	24 ft	7.49 m
Height, platform outdoor on outriggers	18 ft	5.49 m
Height, working driveable outdoor	21 ft 9 in	6.80 m
Height, platform driveable outdoor	15 ft 9 in	4.80 m
Height, working indoor on outriggers	38 ft 1 in	11.78 m
Height, platform indoor on outriggers	32 ft 1 in	9.78 m
Height, working driveable indoor	28 ft 0 in	8.71 m
Height, platform driveable indoor	22 ft 0 in	6.71 m
Height, stowed maximum, rails up	8 ft	2.43 m
Height, stowed maximum, rails folded	6 ft 10 in	2.07 m
Platform height, stowed maximum	4 ft 4 in	1.32 m
Height, guard rails	3 ft 7 in	1.10 m
Width	32.2 in	0.82 m
Length, stowed	8 ft 0 in	2.44 m
Length, platform extended	10 ft 11 in	3.33 m
Platform extension length	35.8 in	0.91 m
Platform dimensions (length x width)	7 ft 5 in x 32.9 in	2.27 m x 0.84 m
Maximum load capacity	500 lbs	227 kg
Maximum wind speed, outdoors	28 mph	12.5 m/s
Maximum wind speed, indoors	0 mph	0 m/s
Wheelbase	6 ft 1 in	1.85 m
Turning radius (outside)	7 ft 0 in	2.1 m
Turning radius (inside)	0 in	0 cm
Ground clearance	5 in	12 cm
Ground clearance Pothole guards deployed	0.9 in	2.3 cm
Weight	5367 lbs	2434 kg
(Machine weights vary with option configurations. See serial label for specific machine weight.)		
Power source	4 Batteries, 6V 210AH	
System voltage	24V	

Hydraulic pressure, maximum (E-drive)	2300 psi	159 bar
---------------------------------------	----------	---------

Tire size	15 x 5 in 38 x 13 cm	
-----------	----------------------	--

Total vibration value to which the hand/arm system is subjected does not exceed 2.5 m/s<sup>2</sup>.

Highest root mean square value of weighted acceleration to which the whole body is subjected does not exceed 1.6 ft/s<sup>2</sup> or 0.5 m/s<sup>2</sup>.

### Operating temperature

Minimum	-20°F	-29°C
Maximum	120°F	48.9°C

### Airborne noise emissions

Sound pressure level at ground workstation	<70 dBA
--	---------

Sound pressure level at platform workstation	<70 dBA
--	---------

<b>Maximum slope rating, stowed position</b>	25% (14°)
--	-----------

<b>Maximum side slope rating, stowed position</b>	25% (14°)
---	-----------

Note: Slope rating is subject to ground conditions with one person in the platform and adequate traction. Additional platform weight may reduce slope rating.

### Drive speeds

Stowed, maximum, hydraulic drive	2.0 mph	3.2 km/h
----------------------------------	---------	----------

Stowed, maximum, E-drive	2.5 mph	4.0 km/h
--------------------------	---------	----------

Platform raised, maximum	0.5 mph	0.8 km/h
	40 ft/55 sec	12.2 m/55 sec

### Floor loading information, GS-3232

Tire load maximum	1840 lbs	835 kg
-------------------	----------	--------

Outrigger load, maximum	2785 lbs	1263 kg
-------------------------	----------	---------

Tire contact pressure	120.8 psi	8.49 kg/cm <sup>2</sup>
	17389 psf	833 kPa

Maximum outrigger pad pressure	221.6 psi	15.58 kg/cm <sup>2</sup>
	31914 psf	1528 kPa

Occupied floor pressure	307 psf	1498 kg/m <sup>2</sup>
		14.69 kPa

Note: Floor loading information is approximate and does not incorporate different option configurations. It should be used only with adequate safety factors.

Continuous improvement of our products is a Genie policy. Product specifications are subject to change without notice or obligation.

# Specifications

Model	GS-2046	
Height, working outdoor	22 ft 4 in	6.98 m
Height, platform outdoor	16 ft 4 in	4.98 m
Height, working indoor	26 ft 1 in	8.13 m
Height, platform indoor	20 ft 1 in	6.13 m
Height, stowed maximum, rails up	7 ft 2 in	2.17 m
Height, stowed maximum, rails folded	5 ft 2 in	1.58 m
Platform height, stowed maximum	3 ft 6 in	1.07 m
Height, guard rails	3 ft 7 in	1.10 m
Width	3 ft 10 in	1.18 m
Length, stowed	8 ft 0 in	2.44 m
Length, platform extended	10 ft 11 in	3.32 m
Platform extension length	36 in	0.91 m
Platform dimensions (length x width)	7 ft 5 in x 3 ft 11 in	2.26 m x 1.18 m
Maximum load capacity	1200 lbs	544 kg
Maximum wind speed, outdoors	28 mph	12.5 m/s
Maximum wind speed, indoors	0 mph	0 m/s
Wheelbase	6 ft 1 in	1.85 m
Turning radius (outside)	7 ft 6 in	2.29 m
Turning radius (inside)	0 in	0 cm
Ground clearance	5 in	12 cm
Ground clearance Pothole guards deployed	0.9 in	2.3 cm
Weight	3913 lbs	1775 kg
(Machine weights vary with option configurations. See serial label for specific machine weight.)		
Power source	4 Batteries, 6V 210AH	
System voltage	24V	
Maximum hydraulic pressure (functions)	2900 psi	200 bar
Tire size	15 x 5 in	38 x 13 cm
Total vibration value to which the hand/arm system is subjected does not exceed 2.5 m/s <sup>2</sup> .		
Highest root mean square value of weighted acceleration to which the whole body is subjected does not exceed 1.6 ft/s <sup>2</sup> or 0.5 m/s <sup>2</sup> .		

## Operating temperature

Minimum	-20°F	-29°C
Maximum	120°F	48.9°C

## Airborne noise emissions

Sound pressure level at ground workstation	<70 dBA
Sound pressure level at platform workstation	<70 dBA

**Maximum slope rating, stowed position** 30% (16.7°)

**Maximum side slope rating, stowed position** 30% (16.7°)

Note: Slope rating is subject to ground conditions with one person in the platform and adequate traction. Additional platform weight may reduce slope rating.

## Drive speeds

Stowed, maximum	2.5 mph	4.0 km/h
Platform raised, maximum	0.5 mph	0.8 km/h
	40 ft/55 sec	12.2 m/55 sec

## Floor loading information, GS-2046

Tire load maximum	2017 lbs	915 kg
Tire contact pressure	134.5 psi	9.45 kg/cm <sup>2</sup>
	19363 psf	927 kPa
Occupied floor pressure	188 psf	916 kg/m <sup>2</sup>
		8.98 kPa

Note: Floor loading information is approximate and does not incorporate different option configurations. It should be used only with adequate safety factors.

Continuous improvement of our products is a Genie policy. Product specifications are subject to change without notice or obligation.

# Specifications

Model	GS-2646	
Height, working outdoor, dual zone	25 ft 8 in	7.99 m
Height, platform outdoor, dual zone	19 ft 8 in	5.99 m
Height, working outdoor, XH	32 ft 1 in	9.96 m
Height, platform outdoor, XH	26 ft 1 in	7.96 m
Height, working indoor, dual zone/XH	32 ft 1 in	9.96 m
Height, platform indoor, dual zone/XH	26 ft 1 in	7.96 m
Height, stowed maximum, rails up	7 ft 7 in	2.32 m
Height, stowed maximum, rails folded	5 ft 7 in	1.70 m
Platform height, stowed maximum	3 ft 11 in	1.2 m
Height, guard rails	3 ft 7 in	1.10 m
Width	3 ft 10 in	1.18 m
Length, stowed	8 ft 0 in	2.44 m
Length, platform extended	10 ft 11 in	3.32 m
Platform extension length	36 in	0.91 m
Platform dimensions (length x width)	7 ft 5 in x 3 ft 11 in	2.26 m x 1.18 m
Maximum load capacity	1000 lbs	454 kg
Maximum wind speed, outdoors	28 mph	12.5 m/s
Maximum wind speed, indoors	0 mph	0 m/s
Wheelbase	6 ft 1 in	1.85 m
Turning radius (outside)	7 ft 6 in	2.29 m
Turning radius (inside)	0 in	0 cm
Ground clearance	5 in	12 cm
Ground clearance Pothole guards deployed	0.9 in	2.3 cm
Weight, dual zone	4346 lbs	1971 kg
Weight, XH	5057 lb	2294 kg
(Machine weights vary with option configurations. See serial label for specific machine weight.)		
Power source	4 Batteries, 6V 210AH	
System voltage	24V	

Maximum hydraulic pressure (functions)	2800 psi	193 bar
--	----------	---------

Tire size	15 x 5 in	38 x 13 m
-----------	-----------	-----------

Vibration value does not exceed 2.5 m/s<sup>2</sup>

Highest root mean square value of weighted acceleration to which the whole body is subjected does not exceed 1.6 ft/s<sup>2</sup> or 0.5 m/s<sup>2</sup>.

### Operating temperature

Minimum	-20°F	-29°C
---------	-------	-------

Maximum	120°F	48.9°C
---------	-------	--------

### Airborne noise emissions

Sound pressure level at ground workstation	<70 dBA
--	---------

Sound pressure level at platform workstation	<70 dBA
--	---------

**Maximum slope rating, stowed position** 30% (16.7°)

**Maximum side slope rating, stowed position** 30% (16.7°)

Note: Slope rating is subject to ground conditions with one person in the platform and adequate traction. Additional platform weight may reduce slope rating.

### Drive speeds

Stowed, maximum	2.5 mph	4.0 km/h
-----------------	---------	----------

Platform raised, maximum	0.5 mph	0.8 km/h
	40 ft/55 sec	12.2 m/55 sec

### Floor loading information, GS-2646

Tire load maximum, dual zone	2127 lbs	965 kg
------------------------------	----------	--------

Tire load maximum, XH	2270 lbs	1030 kg
-----------------------	----------	---------

Tire contact pressure, dual zone	141.8 psi	9.97 kg/cm <sup>2</sup> 859 kPa
----------------------------------	-----------	------------------------------------

Tire contact pressure, XH	151.3 ps	10.64 kg/cm <sup>2</sup> 1044 kPa
---------------------------	----------	--------------------------------------

Occupied floor pressure, dual zone	195 psf	954 kg/m <sup>2</sup> 9.36 kPa
------------------------------------	---------	-----------------------------------

Occupied floor pressure, XH	220 psf	1074 kg/m <sup>2</sup> 10.53 kPa
-----------------------------	---------	-------------------------------------

Note: Floor loading information is approximate and does not incorporate different option configurations. It should be used only with adequate safety factors.

Continuous improvement of our products is a Genie policy. Product specifications are subject to change without notice or obligation.

# Specifications

Model	GS-3246	
Height, working outdoor, dual zone	28 ft	8.71 m
Height, platform outdoor, dual zone	22 ft	6.71 m
Height, working outdoor, XH	38 ft 1 in	11.78 m
Height, platform outdoor, XH	32 ft 1 in	9.78 m
Height, working indoor, dual zone/XH	38 ft 1 in	11.78 m
Height, platform indoor, dual zone/XH	32 ft 1 in	9.78 m
Height, stowed maximum, rails up	8 ft	2.43 m
Height, stowed maximum, rails folded	6 ft	1.82 m
Platform height, stowed maximum	4 ft 4 in	1.32 m
Height, guard rails	3 ft 7 in	1.10 m
Width	3 ft 10 in	1.18 m
Length, stowed	8 ft 0 in	2.44 m
Length, platform extended	10 ft 11 in	3.32 m
Platform extension length	36 in	0.91 cm
Platform dimensions (length x width)	7 ft 5 in x 3 ft 11 in	2.26 m x 1.18 m
Maximum load capacity	700 lbs	318 kg
Maximum wind speed, outdoors	28 mph	12.5 m/s
Maximum wind speed, indoors	0 mph	0 m/s
Wheelbase	6 ft 1 in	1.85 m
Turning radius (outside)	7 ft 6 in	2.29 m
Turning radius (inside)	0 in	0 cm
Ground clearance	5 in	12 cm
Ground clearance Pothole guards deployed	0.9 in	2.3 cm
Weight, dual zone	5218 lbs	2367 kg
Weight, XH	6120 lbs	2776 kg
(Machine weights vary with option configurations. See serial label for specific machine weight.)		
Power source	4 Batteries, 6V 210AH	
System voltage	24V	

Maximum hydraulic pressure (functions)	2600 psi	179 bar
Tire size	15 x 5 in	38 x 13 cm

Total vibration value to which the hand/arm system is subjected does not exceed 2.5 m/s<sup>2</sup>.

Highest root mean square value of weighted acceleration to which the whole body is subjected does not exceed 1.6 ft/s<sup>2</sup> or 0.5 m/s<sup>2</sup>.

### Operating temperature

Minimum	-20°F	-29°C
Maximum	120°F	48.9°C

### Airborne noise emissions

Sound pressure level at ground workstation	<70 dBA
Sound pressure level at platform workstation	<70 dBA

**Maximum slope rating, stowed position** 25% (14°)

**Maximum side slope rating, stowed position** 25% (14°)

Note: Slope rating is subject to ground conditions with one person in the platform and adequate traction. Additional platform weight may reduce slope rating.

### Drive speeds

Stowed, maximum	2.5 mph	4.0 km/h
Platform raised, maximum	0.5 mph	0.8 km/h
	40 ft/55 sec	12.2 m/55 sec

### Floor loading information, GS-3246

Tire load maximum, dual zone	2227 lbs	1010 kg
Tire load maximum, XH	2304 lbs	1045 kg
Tire contact pressure, dual zone	148.5 psi	10.45 kg/cm <sup>2</sup> 1024 kPa
Tire contact pressure, XH	153.6 psi	10.80 kg/cm <sup>2</sup> 1059 kPa
Occupied floor pressure, dual zone	214 psf	1047 kg/m <sup>2</sup> 10.26 kPa
Occupied floor pressure, XH	246 psf	1203 kg/m <sup>2</sup> 11.80 kPa

Note: Floor loading information is approximate and does not incorporate different option configurations. It should be used only with adequate safety factors.

Continuous improvement of our products is a Genie policy. Product specifications are subject to change without notice or obligation.

# Specifications

Model	GS-4046	
Height, working outdoor	29 ft	9.01 m
Height, platform outdoor	23 ft	7.01 m
Height, working indoor	45 ft 0 in	13.89 m
Height, platform indoor	39 ft 0 in	11.89 m
Height, stowed maximum, rails up	8 ft 5 in	2.57 m
Height, stowed maximum, rails folded	6 ft 6 in	1.98 m
Platform height, stowed maximum	4 ft 9 in	1.45 m
Height, guard rails	3 ft 7 in	1.10 m
Width	3 ft 10 in	1.18 m
Length, stowed	8 ft 2 in	2.48 m
Length, platform extended	11 ft 6 in	3.51 m
Platform extension length	36 in	0.91 m
Platform dimensions (length x width)	7 ft 5 in x 3 ft 11 in	2.26 m x 1.18 m
Maximum load capacity	770 lbs	350 kg
Maximum wind speed, outdoors	28 mph	12.5 m/s
Maximum wind speed, indoors	0 mph	0 m/s
Wheelbase	6 ft 1 in	1.85 m
Turning radius (outside)	7 ft 6 in	2.29 m
Turning radius (inside)	0 in	0 cm
Ground clearance	5 in	12 cm
Ground clearance Pothole guards deployed	0.9 in	2.3 cm
Weight	6871 lbs	3117 kg
(Machine weights vary with option configurations. See serial label for specific machine weight.)		
Power source	4 Batteries, 12V 225AH	
System voltage	24V	
Maximum hydraulic pressure (functions)	2350 psi	162 bar
Tire size	15 x 5 in	38 x 13 cm

Total vibration value to which the hand/arm system is subjected does not exceed 2.5 m/s<sup>2</sup>.

Highest root mean square value of weighted acceleration to which the whole body is subjected does not exceed 1.6 ft/s<sup>2</sup> or 0.5 m/s<sup>2</sup>.

## Operating temperature

Minimum	-20°F	-29°C
Maximum	120°F	48.9°C

## Airborne noise emissions

Sound pressure level at ground workstation	<70 dBA
Sound pressure level at platform workstation	<70 dBA

**Maximum slope rating, stowed position** 25% (14°)

**Maximum side slope rating, stowed position** 25% (14°)

Note: Slope rating is subject to ground conditions with one person in the platform and adequate traction. Additional platform weight may reduce slope rating.

## Drive speeds

Stowed, maximum	2.5 mph	4.0 km/h
Platform raised, maximum	0.5 mph 40 ft/55 sec	0.8 km/h 12.2 m/55 sec

## Floor loading information, GS-4046

Tire load maximum	2657 lbs	1205 kg
Tire contact pressure	177.1 psi	12.46 kg/cm <sup>2</sup> 1221 kPa
Occupied floor pressure	275 psf	1342 kg/m <sup>2</sup> 13.16 kPa

Note: Floor loading information is approximate and does not incorporate different option configurations. It should be used only with adequate safety factors.

Continuous improvement of our products is a Genie policy. Product specifications are subject to change without notice or obligation.

# Specifications

## Contents of EC Declaration of Conformity

<Manufacturer's name> hereby declares that the machinery described below complies with the provisions of the following Directives:

1. EC Directive 2006/42/EC, Machinery Directive, under consideration of harmonized European standard EN280 as described in EC type-examination certificate <variable field> issued by:

Kuiper Certificering B.V.  
Van Slingelandtstraat 75, 7331NM  
Apeldoorn  
Netherlands  
NB number 2842

2. EC Directive EMC: 2014/30/EU, under consideration of harmonized European standard EN 61000-6-2 and EN 61000-6-4

3. EC Directive 2000/14/EC, Noise Directive, under consideration of Annex V and harmonized standard EN ISO 3744, internal combustion engine only.

### Test Report:

This machine has been tested and passed the following categories per EN 280:2013+A1:2015 clause 6.3 prior to entering the market:

1. BRAKES: Brakes working properly in forward and reverse.
2. OVERLOAD: Overload tested at XXX% rated load.
3. FUNCTIONAL: Smooth operation at XXX% rated load.
4. FUNCTIONAL: All safety devices working correctly.
5. FUNCTIONAL: Speeds set within permitted specification.

Model / Type: <machine type>

Manufacture Date: <variable field>

Description: <machine classification>

Country of Manufacture: <variable field>

Model: <model name>

Net Installed Power: <only for IC machines>

Serial Number: <variable field>

Guaranteed Sound Power Level: <only for IC machines>

VIN: <where applicable>

Manufacturer: <Manufacturer's name>

Authorized Representative:

Genie Industries B.V  
Boekerman 5,  
4751 XK Oud Gastel,  
The Netherlands

Empowered signatory:

Place of Issue: <variable field>

Date of Issue: <variable field>



[www.genielift.com](http://www.genielift.com)

Distributed By: