

For online reference and to download the manuals for your machines , go to:-

<https://www.e-technical-information.com>

or, scan the QR Code below



OPERATOR'S MANUAL

HS21E - HS6395E - HS21E PRO - HS6395E PRO

Touch screen display

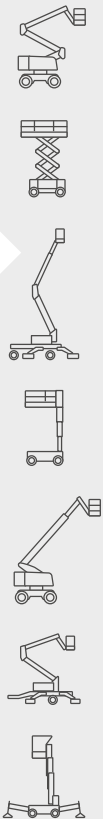

A-Foreword

1	Foreword.....	3
2	Responsibilities.....	4
2.1	Owner's responsibility.....	4
2.2	Employer's responsibility.....	4
2.3	Trainer's responsibility.....	4
2.4	Operator's responsibility.....	4
3	Safety.....	5
3.1	Safety instructions.....	5
4	Safety inquiries.....	13
5	Incident notification.....	14
6	Compliance.....	15
6.1	Product modification.....	15
6.2	Product specifications.....	15
6.3	Change of Ownership Notification.....	15
6.4	Declaration of conformity.....	16

B-Familiarization

1	General safety.....	3
1.1	Intended use.....	3
1.2	Decal content.....	3
1.3	Level of severity.....	4
1.4	Symbols legend and definitions.....	5
1.5	Symbols and colors.....	7
2	Primary machine components.....	8
2.1	Layout.....	8
2.2	Maintenance support.....	9
2.3	Ground control box - Service / Emergency station.....	12
2.4	Platform control box - Main station.....	36
3	Performance Specifications.....	53
3.1	Technical characteristics.....	53
3.2	Working area / Range of motion.....	56
4	Decals and markings locations.....	57

C-Pre-operation inspection

1	Recommendations.....	3
2	Working area assessment.....	4
3	Inspection and Functional test.....	5
3.1	Daily inspection.....	5
4	Safety functional checks.....	9
4.1	Emergency Stop button check.....	9
4.2	Activation of controls.....	9
4.3	Fault detector.....	10
4.4	Automatic engine cut-out (If machine equipped with the option Range Extender) ...	11
4.5	Overload sensing system.....	11

Contents

4.6	Slope warning device.....	11
4.7	Machine braking.....	12
4.8	Travel speed limitation.....	12
4.9	On-board electronics.....	13
4.10	Anti-crush system when lowering.....	13
4.11	Braking test.....	13
4.12	Overload test.....	14

D-Operation instructions

1	Operation.....	3
1.1	Introduction.....	3
1.2	Major description.....	3
1.3	Operation from the ground control box (Service / Emergency station)	3
1.4	Operation from the platform control box (Main station)	4
1.5	Mode operation.....	4
2	Ground control box - Service / Emergency station.....	6
2.1	To start and stop the machine.....	6
2.2	Movement control.....	6
2.3	Additional controls.....	6
3	Platform control box - Main station.....	7
3.1	To start and stop the machine.....	7
3.2	Drive and steer control.....	7
3.3	Movement control.....	10
3.4	Additional controls.....	10
4	Rescue and emergency procedures.....	11
4.1	In case of power loss.....	11
4.2	To rescue operator in platform.....	11
4.3	No power available.....	12
5	Transportation.....	16
5.1	Transport configuration.....	16
5.2	Machine stowage for transport.....	17
5.3	Loading by ramp.....	17
5.4	Folding guardrails.....	18
5.5	Unloading.....	28
5.6	Towing.....	28
5.7	Storage.....	32
5.8	Lifting operation.....	35
6	Cold Weather Recommendations.....	38
6.1	Hydraulic oil.....	38
6.2	Li-ion battery.....	38
7	Battery care and maintenance (For machines equipped with the lithium-ion battery option)	39
7.1	Battery recharge.....	39
7.2	Optimise battery life.....	41

E-General Specifications

1	Machine dimensions.....	3
---	-------------------------	---

Contents

2	Major component masses.....	5
3	Acoustics and vibrations.....	6
4	Wheel/Tire assembly.....	7
4.1	Technical specifications.....	7
4.2	Inspection and maintenance.....	7

F-Maintenance

1	General.....	3
2	Maintenance Schedule.....	4
3	Inspection program.....	5
3.1	General program.....	5
3.2	Daily inspection.....	5
3.3	Periodic inspection.....	5
3.4	Reinforced inspection.....	6
3.5	Major inspection.....	6
4	Repairs and adjustments.....	7

G-Options

1	Compatibility.....	3
2	Advanced Access Management - Access control and usage restriction.....	4
2.1	Description.....	4
2.2	Additional functions.....	5
2.3	SUPER USER status.....	6
2.4	Code for removing restrictions.....	6
2.5	Operation.....	7
3	Range Extender.....	17
3.1	Description.....	17
3.2	Characteristics.....	17
3.3	Safety precautions.....	22
3.4	Pre-operation inspection.....	22
3.5	Installing / Removing the Range Extender.....	23
3.6	Specific decals.....	28
4	Fast Charge.....	29
4.1	Description.....	29
4.2	Safety precautions.....	29
4.3	Specifications.....	29
4.4	Operation.....	30
5	Plate holder/Tube holder.....	31
5.1	Description.....	31
5.2	Characteristics.....	31
5.3	Safety precautions.....	32
5.4	Pre-operation inspection.....	32
5.5	Disassembly - Assembly	33
5.6	Operation.....	35
5.7	Strapping (Strap not provided)	37
5.8	Storage of the supports on the platform.....	38
5.9	Folding guardrails if machine equipped with plate/tube holder support.....	38

Contents

6	Activ'Shield Bar Scissors - Secondary guarding system (if the function is present and the device is installed in its support)	40
6.1	Description.....	40
6.2	Characteristics.....	41
6.3	Safety precautions.....	41
6.4	Pre-operation inspection.....	42
6.5	Operation.....	43
6.6	Specific decals	44
6.7	Insert the console into its support.....	44
7	Central tube holder	47
7.1	Description.....	47
7.2	Characteristics.....	47
7.3	Safety precautions.....	48
7.4	Pre-operation inspection.....	49
7.5	Disassembly - Assembly	49
7.6	Strapping (Supplied strap)	52
7.7	Storage.....	53
7.8	Folding guardrails if machine equipped with plate/tube holder support.....	53

H-Other information

1	Conditions of warranty	3
2	Subsidiary contact information	4
2.1	California warning.....	5

I-Records

1	Intervention register	3
----------	------------------------------------	----------

A - Foreword

1	Foreword.....	3
2	Responsibilities.....	4
2.1	Owner's responsibility.....	4
2.2	Employer's responsibility.....	4
2.3	Trainer's responsibility.....	4
2.4	Operator's responsibility.....	4
3	Safety.....	5
3.1	Safety instructions.....	5
4	Safety inquiries.....	13
5	Incident notification.....	14
6	Compliance.....	15
6.1	Product modification.....	15
6.2	Product specifications.....	15
6.3	Change of Ownership Notification.....	15
6.4	Declaration of conformity.....	16

1 Foreword

You have just purchased a HAULOTTE® product and we would like to thank you for your business.

The aerial work platform is a device for lifting people designed and manufactured with the intent to enable users to access overhead elevated temporary workplaces with the necessary tools and equipment. All other uses or alterations/modifications to the aerial work platform must be approved by HAULOTTE®.

This manual shall be considered a permanent component of the machine and shall be kept with the aerial work platform in the designated Manual Holder, at all times.

Safe operation of this product can only be assured if you follow the operating instructions contained in this manual. To ensure the safe and appropriate use of this equipment, only trained personnel are authorised to use and carry out maintenance on the aerial work platform.

We would particularly like to draw your attention to 2 essential points:

- Comply with safety instructions.
- Use this equipment within the performance limits specified by this user manual.

With regard to the designation of our equipment, we stress that this is purely for commercial purposes and not to be confused with the technical specifications. Only the specifications in this manual should be used to study the suitability of the equipment for the intended use.

This operator's manual is specific to the HAULOTTE® products listed on the cover page of this manual.



Original language and version: Manuals in English and French are the original instructions. Manuals in other languages are translations of the original instructions.

The user manual does not replace the necessary training that is required for all of this machine's operators. HAULOTTE® has compiled this manual to assist in safe and efficient operation of the products covered in the manual.

The manual must be available to all operators and must be kept in a legible condition. Additional copies can be ordered from HAULOTTE Services®.

Stay Safe and keep working with HAULOTTE®!

For online reference and to download the manuals for your machines HAULOTTE®, go to:

<https://www.e-technical-information.com>

Or, scan the QR Code below:



2 Responsibilities

2.1 Owner's responsibility

The owner (or hirer) has the obligation to:

- To inform operators of the instructions contained in the Operator's Manual.
- Follow local regulations regarding operation of the machine.
- Replace all manuals or labels that are missing or in poor condition. Additional copies can be ordered from HAULOTTE Services®.
- To establish a preventive maintenance program in accordance with the manufacturer's recommendations, taking into account the environment and severity of use of the machine.
- To perform periodic inspections in accordance with HAULOTTE® recommendations and local regulations.

All malfunctions and problems identified during the inspection shall be corrected before the aerial work platform is returned to service.

2.2 Employer's responsibility

The employer (or plant superintendent) is required:

- To train and check the training of users.
- To authorise the trained user(s) to use the machine.
- To inform and familiarize the operator with the local regulations.
- Forbid anyone from operating the machine if:
 - Under the influence of drugs, alcohol, etc.
 - Subject to fits, convulsions, dizziness, etc.

2.3 Trainer's responsibility

- The trainer must be qualified to provide training to operators in accordance with applicable local regulations.
- The training must include all of the instructions in this manual.
- The training must be given in an obstacle-free area until the trainee is considered competent as defined by the training program undertaken.

2.4 Operator's responsibility

The operator has the obligation to:

- Read and understand the contents of this manual and familiarize himself/herself with the decals affixed on the machine.
- To inspect the machine before use according to HAULOTTE®'s recommendations..
- Inform the owner (or hirer) if the manual or any decals are missing or are not legible.
- Inform the owner (or hirer) of any machine malfunction.

Operators must ensure that the inspections have been carried out by the owner and that they can use the machine for the purpose intended by the manufacturer.



All users (driver, passenger, maintainer, transporter, etc.) must familiarise themselves with the emergency controls and machine operation in case of an emergency.

The operator has the obligation to stop using the machine in the event of malfunction or safety problems on the machine or in the work area and report the problem immediately to his/her supervisor.

3 Safety

3.1 Safety instructions

3.1.1 Incorrect use

- Do not use the machine outside of the conditions specified in this manual.
- Do not use the machine as a crane, material lift or elevator.



- Do not use the work platform as a hoisting machine (crane) by suspending a load outside of the platform.
- Do not tie the platform to an adjacent fixed or mobile structure.
- Do not use/operate the machine when alone. A survey person or immediate Supervisor must be present on the ground in case of emergency.
- Do not use a faulty or poorly maintained machine. Remove defective/damaged machine from service.
- Do not climb onto the compartment covers of the machine.
- Do not replace items critical to machine stability with items of different weight or specification.
- Do not replace the wheels installed in the factory with wheels with different characteristics.
- Do not alter or disable machine components that in any way affect safety and stability.
- Do not disable the safety devices.
- Do not use the machine if a label is missing or illegible.
- Do not damage, modify or hide machine labels or inscriptions.

3.1.2 Falling Hazards

N.B.-:THE GUARDRAIL IS THE MAIN PROTECTION SYSTEM AGAINST FALLS FROM THE MOBILE LIFTING PLATFORM (PEMP) .

Before commencing operation:

- Ensure that guard rails are correctly installed and secured.
- Ensure that the step(s) are locked properly.
- Ensure that gate or sliding bar is in its securely locked position.
- If using a machine that has a swing gate, check that the entry gate closes by itself and gate latches and locks.



- Remove oil or grease from the steps, floor, handrail and the guardrails.
- Clean the floor of the platform (no debris).

To enter or exit from the platform:

- The machine must be completely stowed (Access position) .
- Face the machine to access the opening to the platform.
- Keep 3 points of contact on the steps and the guardrail.
- Keep fingers away from moving parts near entry gate.



A - Foreword

When in the platform:

- Where personal fall protection equipment (FPE) is required by the employer, a competent authority or local regulations, we recommend using a full harness with a safety line.
- Personal fall protection equipment must only be fastened to approved fall protection anchoring points on the platform provided for this purpose.
- Refer to this decal located on the platform.
- Safety lines must never be attached to an object or structure outside of the work platform.
- Hold on securely to the guardrails.
- Always keep your feet firmly on the floor of the platform.
- Do not sit, stand, or climb on the platform guard rails.
- Do not lean on the gate or sliding bar.
- Do not lean over the guard rails or climb over them. Only work in the platform area within the guard rails.
- Do not exit the platform until it is in the completely stowed position.
- Do not use the guardrail as a means of access to climb in or out of the platform.

**3.1.3 Overtipping / Tip-over Hazards****Before positioning and operating the machine:**

- Ensure that the surface is capable of supporting the machine weight including the rated capacity.



B 3.1 - Technical characteristics.

- Do not exceed the maximum rated capacity that includes the weight of both material and allowed number of occupants. Do not exceed the allowable number of occupants.
- Do not increase the working height (using extensions, ladder, etc.).
- Do not place ladders or scaffolds in the platform or against any part of this machine.
- Position loads uniformly in the centre of the work platform.
- Do not use the machine at wind speeds that are above the permissible threshold. Refer to the display on the work platform to view the permissible wind speed.
- Do not increase the surface area of the platform exposed to wind. This includes adding panels, mesh, banners. Failure to follow this instruction may lead to a loss of stability and as a result, the machine could tip over.
- Do not raise the platform or move the machine with the platform raised on a slope with a gradient greater than the machine's permissible limit.
- Do not drive the machine on slopes or grades exceeding the specified limits.



A - Foreword

- Do not pull or push towards any object outside of the platform. Do not exceed the maximum allowable side force stated in the performance specifications.
- Do not use the machine to support any external structure.
- Do not use the machine to tow other machines or to drag materials.
- **Using the machine on a slope:**

By slope is meant the tilt of a surface in relation to the horizontal plane.

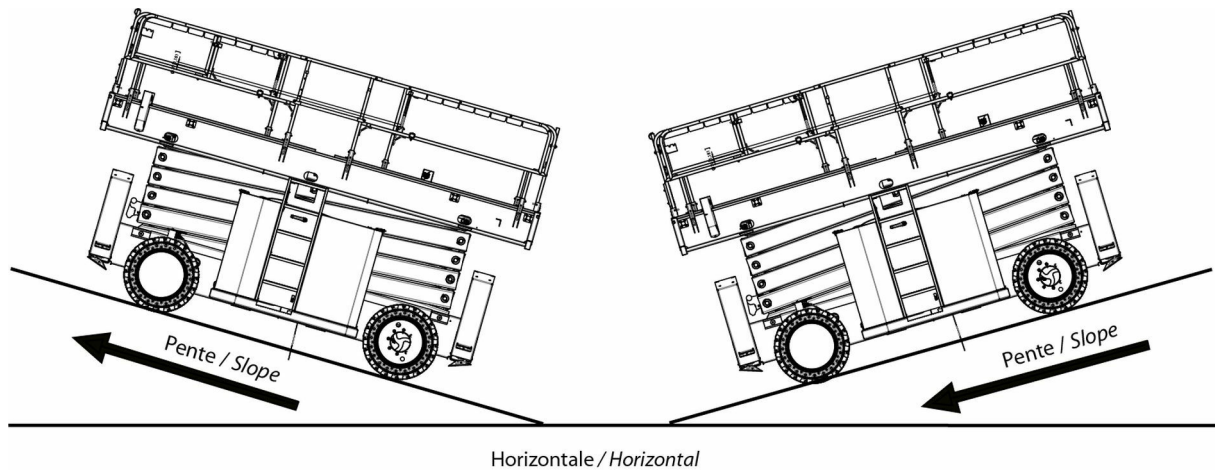

Do not drive the machine on slopes with gradients exceeding the authorised limit for the machine.



B.3.1 - Technical characteristics.



While driving on a slope:

- Always orientate the machine in the direction of the slope.
- Stow the machine completely.
- Do not travel down slopes in high speed.



- Do not make a U turn on the slope.

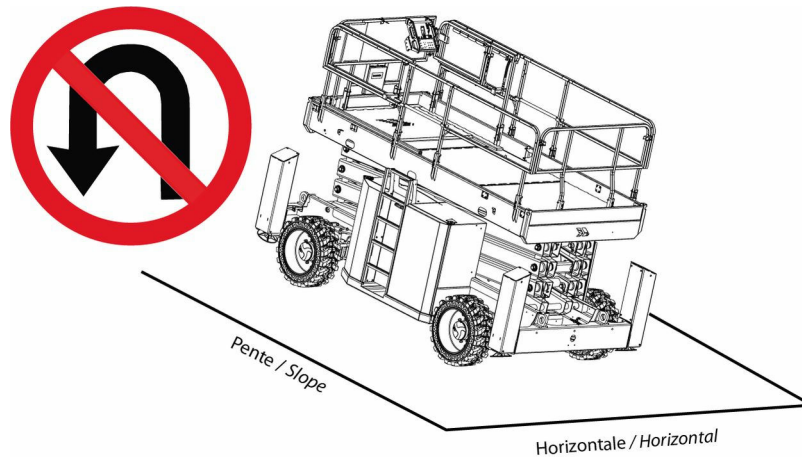

- Do not drive diagonally or sideways on a slope.

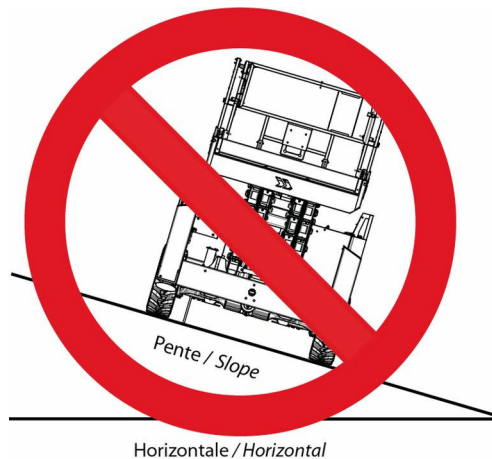

N.B.-:

THE MACHINE MAY AUTOMATICALLY REDUCE THE DRIVE SPEED AND ACTIVATE DIFFERENTIAL LOCKING ACCORDING TO THE GRADIENT OF THE SLOPE.

USING THE DIFFERENTIAL LOCK IS RECOMMENDED IF ADHESION IS POOR OR THE GROUND IS UNEVEN.

WIND: the aerial work platform can be used up to the maximum wind speed indicated in the specifications in this manual. To identify the local wind speed, use the Beaufort scale below, a wind gauge or an anemometer.

N.B.-:THE BEAUFORT SCALE OF WIND FORCE IS ACCEPTED INTERNATIONALLY AND IS USED WHEN COMMUNICATING WEATHER CONDITIONS. A WIND SPEED RANGE AT 10 M (32 FT 9 IN) ABOVE FLAT, CLEAR LAND IS ASSOCIATED WITH EACH DEGREE.

Beaufort scale

Force	Meteorological description	Observed effects	m/s	km/h	mph
0	Calm	Smoke rises vertically.	0 - 0,2	0 - 1	0 - 0,62
1	Very light breeze	Smoke indicates the wind direction.	0,3 - 1,5	1 - 5	0,62 - 3,11
2	Light breeze	Wind felt on the face. Leaves rustle. Weather vanes turn.	1,6 - 3,3	6 - 11	3,72 - 6,84
3	Slight breeze	Leaves and small twigs in constant motion. Flags move slightly.	3,4 - 5,4	12 - 19	7,46 - 11,8
4	Nice breeze	Raised dust and loose papers. Small branches are moved.	5,5 - 7,9	20 - 28	12,43 - 17,4
5	Nice breeze	Small trees in leaf to sway. Crested wavelets form on inland waterways.	8,0 - 10,7	29 - 38	18,02 - 23,6
6	Cool wind	Large branches in motion. Power lines and chimneys 'sing'. Umbrellas used with difficulty.	10,8 - 13,8	39 - 49	24,23 - 30,45
7	Near gale	Whole trees in motion. Inconvenience felt when walking against wind.	13,9 - 17,1	50 - 61	31 - 37,9
8	Gale	Some branches break. Generally we cannot walk against the wind.	17,2 - 20,7	62 - 74	38,53 - 45,98
9	Strong gale	The wind causes slight damage to buildings. Tiles and chimney stacks are blown off.	20,8 - 24,4	75 - 88	46,60 - 54,68

3.1.4 Risk of electric shock (electrocution)



Risk of death or serious injuries.

The machine is not electrically insulated and does not provide protection from contact or proximity to electrically charged conductors.

Always position all parts of the aerial work platform, the occupants, accessories and tools at a reasonable distance from power lines to ensure that no part of the work platform accidentally comes into contact with a power line.

Apply the local regulations or those of the employer with regard to the safety distances. If this is not possible, follow the distances in the table below at a minimum:

Minimum safe approach distances

Electric voltage	Minimum safety distance	
	Mètre	Feet
0 - 300 V	Avoid contact	
300 V - 50 kV	3	10
50 - 200 kV	5	15
200 - 350 kV	6	20
350 - 500 kV	8	25
500 - 750 kV	11	35
750 - 1000 kV	14	45

- Do not operate the machine or charge the batteries in hazardous environment ( D 7 - Battery care and maintenance).

**Risk of electrification or electrocution:**

- DC, for > 60 volts or a capacity > 180 A.h ;
- AC for > 25 volts.

Before any intervention on the electrical circuit, or for any work near a LIVE part, the machine must be locked out by an authorised and properly trained person. After it is locked out, and before any intervention on the electrical power circuit, wait 5 minutes for the voltage to drop to 0 Volt. Using a voltage absence tester, make sure that the voltage is definitely at 0 Volt.  MS0399 - Lock-out procedure.

Reminder of voltages and currents present on the machine:

- 12 volts DC / VDC (DC direct current version)
- 77 volts DC / VDC (DC direct current version)
- 51 volts AC / VAC (AC alternating current version)
- 110 / 220 VAC or 220 / 380 VAC
- Capacities > 180 Ah (For example, 6 Volts - 331 Ah semi-traction batteries in C5 or 390 Ah in C20) :

N.B.-: NATIONAL REGULATIONS MAY REQUIRE TRAINING FOR OPERATORS FOR OPERATIONS ON THE ELECTRICAL PARTS.

- Do not operate the machine when close to live power lines, consider the movement of the machine and the sway of the electric power lines particularly in windy conditions.
- Do not operate the machine during lightning, thunderstorms, snow/ice or any weather condition that could compromise operator safety.
- When using the platform AC power supply, ensure it is protected with a circuit breaker and residual current device.
- Do not use the machine as a ground for welding.
- Do not weld on the machine without first disconnecting the battery terminals.
- Always disconnect ground cable first.



A - Foreword

Keep away from the machine if it contacts energized power lines. Personnel on the ground or in the platform must not touch or operate the machine until energized power lines are shut off.



The user must not leave the platform if it comes into contact with a power line.



3.1.5 Explosion / Fire Hazards

- Always wear protective clothing, glasses or a face protection shield and gloves when working on batteries or energy sources.



- Do not start the engine if you smell or detect liquid propane gas (LPG), gasoline, diesel fuel or other explosive substances.
- Do not work on or operate a machine in an explosive or flammable atmosphere / environment.
- Do not touch hot components.
- Do not bridge the battery terminals with metallic objects.



- Do not expose the battery to fire, sparks, open flames, lighted tobacco, or any other source of heat.
- Do not open the batteries.
- Do not fill the fuel tank with the engine running, close to naked flames and/or while smoking.



3.1.6 Crushing / Collision Hazards



Before using the machine, mark out the machine's work and circulation area using a marking system appropriate to the task at hand and the work environment.

When in the platform:

- Check the work area for overhead clearance, for any obstacles besides and below the platform when raising/lowering the platform and or before driving.
- During movement, keep all the parts of the body inside the platform. Hold onto the guardrails on the opposite side to any surrounding structures.
- To position machine close to a building/structure, use extension deck feature, instead of driving machine closer to structure.
- Before lowering the platform, the extensions must be retracted to ensure visibility and avoid potential contact with surrounding structures.

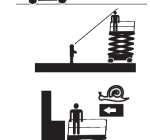
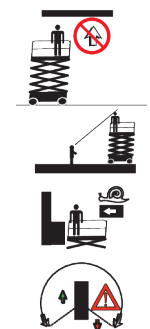

- Warn personnel not to work, stand or walk under an extended extension.
- Always ensure that the chassis is never kept any closer than 1 m (3 ft 3 in) to holes, bumps, slopes, obstructions, debris and ground coverings that may hide holes and other dangers.
- Maintain a distance of at least 1 m (3 ft 3 in) or any signs on the worksite.

A - Foreword

- Keep non-operating personnel at least 5 m (16 ft 5 in) away from the machine when driving.
- Become familiar with the driving direction:
 - Check the direction of movement with the help of the red or white arrows on the chassis and on the platform control box.
 - Also note that when changing the driving direction (Forward <> Reverse) the joysticks or switches must return to the neutral position before reversing the drive direction and for movement to occur.
- Hold on securely to the guardrails.
- Personal Protection Equipment (EPI) :
 - The occupants of the aerial work platform must wear personal protection equipment and comply with local regulations in force.
 - Operators must comply with the safety standards of the job site and the employer, as well as the applicable state regulations relating to the use of personal protective equipment.
 - All personal fall protection equipment (PFPE) must comply with current regulations, must be inspected and used in accordance with the manufacturer's instructions.
- Avoid contact with fixed or mobile obstacles (other machines).
- Other machines (crane, aerial work platform, etc.) operating in the work area increase the risk of crushing or collision. Restrict the operation of machines moving within the aerial work platform work area.
- When driving, position the platform so as to provide the best possible visibility and to avoid any blind spots.
- Take into consideration the stopping distance, reduced visibility and blind spots of the machine.
- Limit travel speed to suit the ground surface condition, slope (incline), and people in the vicinity.

3.1.7 Risk of involuntary movements

Never use a damaged or malfunctioning machine.

Always respect the following rules:

- Maintain clearance from high voltage lines.
- Maintain clearance from generators, radar, electromagnetic fields.
- Never expose the batteries or electrical components to water (high pressure washer, rain).

4 Safety inquiries

Inquiries relating to design criteria/specifications of a product, standards compliance, or overall machine safety should be sent to the HAULOTTE® PRODUCT SAFETY department.

Each inquiry or request should include all relevant information; including contact name, telephone number, mailing address, email address, plus the machine model and serial number.

The HAULOTTE® Product Safety department will evaluate each request/inquiry and will provide a written response.

5 Incident notification

Notify HAULOTTE® immediately when a HAULOTTE® product has been involved in an incident/accident leading to personal injury or death, or when there is a major property damage.

HAULOTTE Group - EUROPE Product Safety Department

Address: Rue Emile Zola - 42420 Lorette - France

Tel: +33 (0)4 77 29 24 24

Email: productsafety.europe@haulotte.com

HAULOTTE Group - Australia, India and Asia Product Safety Department

Address: No.26 Changi North Way - Singapore 498812 - Singapore

Tel: +65 6546 0123

Email: productysafety.apac@haulotte.com

HAULOTTE Group - North & South America Product Safety Department

Address: 3409 Chandler Creek Rd. - Virginia Beach, VA 23453 - United States

Tel: +1 757 689 2146

Email: productsafety.americas@haulotte.com

Connect to our website: www.haulotte.com



6 Compliance

6.1 Product modification

It is strictly forbidden to modify a HAULOTTE® product. Any modification may violate Haulotte design parameters, local regulations and industry standards.

Any requests for modification must be formulated in writing (form) and be approved by the manufacturer.

Do not hesitate to contact HAULOTTE Services®, should you have any questions relating to the issued bulletin(s) or with questions on the policy itself.

6.1.1 Implementing manufacturer safety campaigns

It is essential to implement the safety campaigns issued by the manufacturer. All of these campaigns are accessible on our website.

Connect to our website: www.haulotte.com



Never market (or sell) a machine without first having carried out all of the safety campaigns.

6.2 Product specifications

HAULOTTE® cannot be held liable for any changes to the technical characteristics/specifications contained in this manual. HAULOTTE® has a continuous improvement policy in place for its product range. Given this policy, the Company reserves the right to modify products technical characteristics / specifications without notice.

6.3 Change of Ownership Notification

It is important and necessary to keep HAULOTTE Services® updated with current ownership of the machine. This way, HAULOTTE® will be able to provide the necessary support for the product. If you have sold or transferred this machine(s); it is your responsibility to notify HAULOTTE Services®. It is not required to include Lessees/Renters of Leased/Rented machines on this form.

Connect to our website: www.haulotte.com



6.4 Declaration of conformity



The CE declarations of conformity only apply to machines that have been approved and commissioned within the European Community (EC).

6.4.1 Declaration of conformity - All machines



The UKCA declarations of conformity only apply to machines that have been approved and commissioned within the United Kingdom (UK).

Declaration of conformity - UKCA and CE directive

UKCA/EC DECLARATION OF CONFORMITY

HAULOTTE GROUP

Adress of division

We hereby declare that this machine conforms with all the relevant provisions of the Regulations listed below

Mobile Elevating Work Platform, Type <>, Group <>

<p>Commercial name In compliance with the Model Type Serial number</p>	<p>Commercial name of the concerned machine Model type of the concerned machine Serial number of the machine concerned</p>
---	---

Conforms with provisions of the Regulations listed below :

<p>CE</p> <p>EC Machinery Directive 2006/42/CE EC Directive electromagnetic compatibility 2014/30/EU EU RED Directive on radio equipment (if machine equipped) 2014/53/UE EC Outdoor Noise Directive Measurement method LWA, Guaranteed sound level LWA, Maximum sound level</p>	<p>UKCA</p> <p>Supply of Machinery (safety) 2008/97 amended SI2011/1043/2157 2019/696 Electromagnetic compatibility 2016/875/1091 amended SI 2017/1206, 2019/696 Radio equipment (if machinery equipped) 2017 2000/14/EC Annex III-B dB</p>
---	--

This machine has been type examined by :

Name and address of the Authorized body :	Name and address of Approved body

Certificate number	Certificate number

Harmonized standard(s) used as reference(s) : EN280-1	This machine also fulfils the principles of the designed standards EN280-1
--	---

Manufacturer and the person authorised to compile the technical file:

<p>HAULOTTE GROUP Compliance Manager Rue Emile Zola CS30045 42420 LORETTE FRANCE</p>	<p>HAULOTTE UK Ltd General Manager UK and Ireland Unit 1 gravelly Way, Four Ashes Wolverhampton, West Midlands WV10 7 GW ENGLAND</p>
---	---

Name and signature
Division Director

Place and date

haulotte.com

6.4.2 Declaration of conformity - Electric platforms

Declaration of conformity - CE directive



DECLARATION DE CONFORMITE CE
EC DECLARATION OF CONFORMITY



Fabricant et personne autorisée à constituer le dossier technique :
 Manufacturer and the person authorised to compile the technical file:

<p>HAULOTTE GROUP Adresse du site de production du Address of the division</p>	<p>HAULOTTE GROUP RUE EMILE ZOLA CS 30045 42420 LORETTE FRANCE</p>
---	---

Nacelle élévatrice de personnel
Mobile Elevating Work Platform

<p>En conformité avec le modèle type In compliance with the Model Type</p> <p>Nom commercial Commercial name</p> <p>Numéro de série Serial number</p> <p>Organisme notifié Notified body</p> <p>Numéro de certificat Certificate number</p> <p>Capacité nominale Rated Capacity</p>	<p>Modèle type de la machine concernée Type mode of the concerned machine</p> <p>Nom commercial de la machine concernée Commercial name of the concerned machine</p> <p>Numéro de la machine concernée Serial number of the machine concerned</p> <p>Nom et adresse de l'organisme notifié Name and address of notified body</p> <p>Numéro de certificat du type de machine Certificate number of the type of machine</p> <p>Charge maximale d'utilisation de la machine concernée Rated capacity of the concerned machine</p>
---	--

Nous déclarons que cette machine est conforme aux dispositions des Directives suivantes
 We hereby declare that this machine conforms with all the relevant provisions of the Directives listed below

<p>Directive machine CE EC Machinery Directive</p> <p>Se conforme aux principales exigences de la norme harmonisée This machine also fulfils the principles of the harmonised standard</p> <p>Directive compatibilité électromagnétique CE EC Directive on electromagnetic compatibility</p> <p>Directive CE RED concernant les équipements radioélectriques (si machine équipée) EU RED Directive on radio equipment (if machine equipped)</p>	<p>2006/42/CE</p> <p>EN280-1</p> <p>2014/30/EU</p> <p>2014/53/UE</p>
---	--

Cette déclaration porte exclusivement sur la machine dans l'état où elle a été placée sur le marché.
 This declaration relates exclusively to the machinery in the state in which it was placed on the market

Toute modification de la machine décrite ci-dessus a pour effet d'invalider cette déclaration.
 Any modification to the above described machine violates the validity of this declaration

<p>Nom et signature / Name and signature Division Director</p>	<p>Lieu / Place Date / Date</p>
---	--

haulotte.com

MMZ6910H-A4 - V2.0.6 - 04662096008319292MMZ691PF

B - Familiarization

1	General safety.....	3
1.1	Intended use.....	3
1.2	Decal content.....	3
1.3	Level of severity.....	4
1.4	Symbols legend and definitions.....	5
1.5	Symbols and colors.....	7
2	Primary machine components.....	8
2.1	Layout.....	8
2.2	Maintenance support.....	9
2.3	Ground control box - Service / Emergency station.....	12
2.4	Platform control box - Main station.....	36
3	Performance Specifications.....	53
3.1	Technical characteristics.....	53
3.2	Working area / Range of motion.....	56
4	Decals and markings locations.....	57

B - Familiarization

1 General safety

1.1 Intended use

Do not operate the product in the following situations:

- On soft, unstable or cluttered ground.
- With wind blowing faster than the permissible limit:
 - Check the allowable wind speed specified in the performance specifications tabulation.
 - Consult the Beaufort scale.
- Close to power lines. Keep a safe distance.
- If the machine is stored at a temperature out of range : From - 20°C (- 4°F) to + 50°C (+ 122°F).
- In an explosive atmosphere / environment.
- During storms.
- In the presence of strong electromagnetic fields.

N.B.-:USE THE MACHINE UNDER "NORMAL" CLIMATIC CONDITIONS. IF YOU NEED TO USE THE MACHINE IN CLIMATIC CONDITIONS LIKELY TO CAUSE DETERIORATION (EXTREME : HUMIDITY, TEMPERATURES, SALINITY, CORROSIVENESS, ATMOSPHERIC PRESSURE), CONTACT HAULOTTE SERVICES®. REDUCE INTERVALS BETWEEN SERVICING.

N.B.-:IN HARSH ENVIRONMENTS (HIGH LEVELS OF SALINITY IN THE ATMOSPHERE: CLOSE TO THE SEA, INDUSTRIAL ENVIRONMENT WITH CHLORIDE EMISSIONS AND/OR HUMIDITY > 70%), WE RECOMMEND APPLYING SOLVENT-BASED OIL TO THE ENTIRE MACHINE.

1.2 Decal content

The purpose of the labels on the machine is to alert the user to the conditions of use and risks related to aerial work platforms.

Decals provide the following information:

- The level of severity.
- The specific hazard.
- A method to avoid, suppress or reduce the hazard.
- Descriptive text (where required).

Familiarize yourself with the decals and the hazard severity levels.

The decals must be kept in good condition. Promptly replace all decals that are no longer legible.

Familiarize yourself with the decals and their respective color codes.

Additional decals can be ordered from HAULOTTE Services®.

CE, UKCA, AS and EAC standards - Label warning risk



Marking	Description
1	Risk identification symbol
2	Avoidance symbol pictorial

B - Familiarization

CE, UKCA, AS and EAC standards - Label informing about an important function of the machine

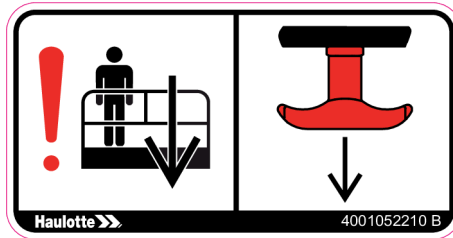

ANSI and CSA standards



Marking	Description
1	Risk identification symbol
2	Level of severity
3	Avoidance symbol pictorial
4	Avoidance text

1.3 Level of severity





















Color	Title	Description
		Danger: Indicates a hazardous situation which if not avoided, WILL result in death or serious injury.
		Warning: Indicates a hazardous situation which if not avoided, COULD result in death or serious injury.
		Caution: Failure to comply could result in minor or moderate injury.
		Notice: Indicates recommended practices if not followed, may result in a malfunction or damage the machine or its components.
		Procedure: Indicates a maintenance operation.

B - Familiarization















1.4 Symbols legend and definitions

Symbols are used throughout this manual to depict hazards, avoidance measures and indicate when information is required.

Refer to the following table to familiarize yourself with these symbols.

Symbol	Description	Symbol	Description	Symbol	Description
	Risk of crushing or pinning		Foot crushing hazard		High pressure fluid ejection hazard
			Hand crushing hazard		Crushing hazard
			Health/safety hazards related to chemicals		Burn hazard
	Risk of electrocution		Burns and scalds from contact with flames, explosion or radiation from heat sources		Injury from Electric arcs - Energy supply disconnecting devices - Batteries fire, emissions, etc
	Fall hazard		Tip over due to excessive loading / wind load and excessive ground slope		Relate and coordinate directional arrows on the chassis with those on the control box
	Do not put foot in this area		Do not put your hand in this area		Keep away from product working area
	Use of high-pressure cleaners prohibited		Ensure entry drop rail is down		

B - Familiarization







Symbol	Description	Symbol	Description	Symbol	Description
	Flames prohibited		Maintain safe clearance from high voltage electrically charged conductors as described in manual - Do not use in thunderstorms		Overload
	Refer to operator manual		Safety belt		Use appropriate lanyard attached to dedicated anchor point.
	Wheel pressure		Enable switch		Use safety prop before attempting any maintenance work
	Tow point		Tie down point		Lift point
	Keep away from hot surfaces		Wear protective equipment		

B - Familiarization

1.5 Symbols and colors

Symbols and colors are used to alert the operator of safety precautions and/or to highlight important safety information.

The following safety symbols are used throughout this manual to indicate specific hazards and the hazard severity level when operating or maintaining the Aerial Work Platform.

Symbol	Description
	Danger: Risk of injury or death
	Caution: Risk of material damage
	Prohibited action
	Reminder to use good practice or follow pre-operation checks
	Cross-reference to another part of the manual
	Cross-reference to another manual
	Cross-reference to repair (contact HAULOTTE Services®)
N.B.:	Additional technical information

B - Familiarization

2 Primary machine components

2.1 Layout

HS21E - HS6395E - HS21E PRO - HS6395E PRO

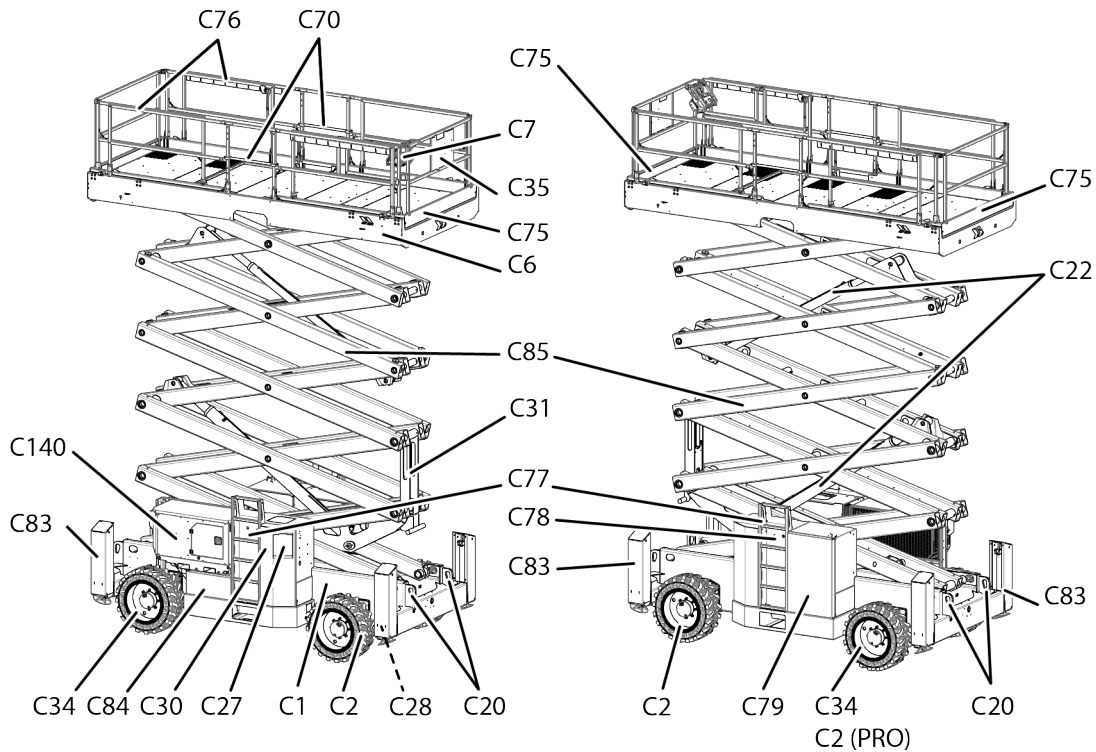

Marking	Description	Marking	Description
C1	Chassis	C35	Document holder
C2	Drive and steer wheel	C70	Platform access bar
C6	Platform	C75	Platform extensions (if equipped)
C7	Platform control box - Main station	C77	Platform access ladder
C20	Anchorage point	C76	Guardrail
C22	Scissors lifting cylinder	C78	Hood locking catch
C27	Ground control box - Service / Emergency station + Universal plug	C79	Battery tray
C28	Tilt sensor	C83	Stabiliser
C30	Hydraulic oil tank	C84	Hydraulic circuit
C31	Maintenance support	C85	Scissors
C34	Drive wheels (and steered wheels, if fitted)	C140	Range Extender (If equipped)

B - Familiarization

Universal plug connection (Options socket)

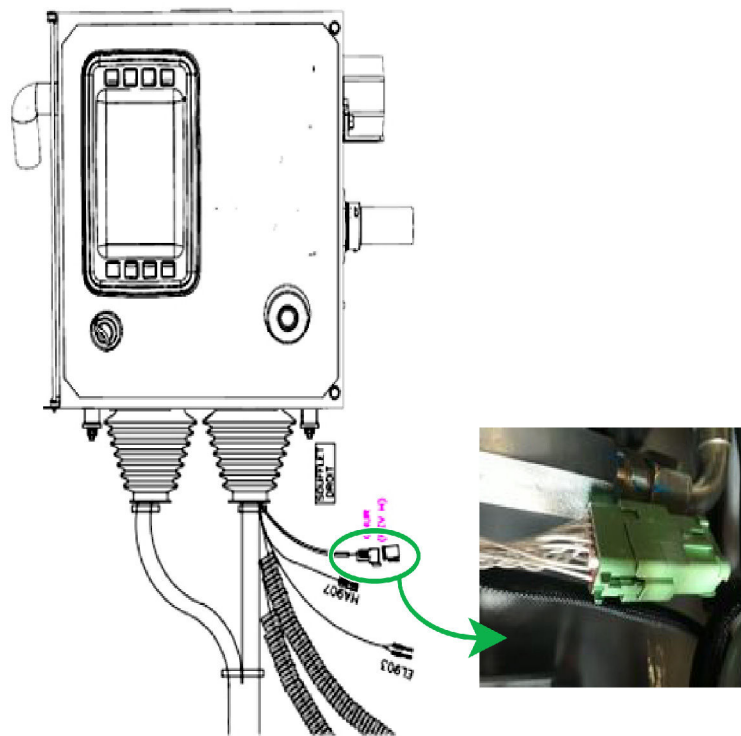

2.2 Maintenance support



The maintenance prop must be in place before any maintenance operation of the arm is begun.



Before placing in maintenance configuration:

- Ensure that the platform is empty and that the machine is in transport configuration (extension retracted and locked, extendable structure (scissors) folded up, directional wheels parallel to the frame, etc.).
- If carrying out maintenance indoors, ensure that there is sufficient ceiling height before lifting the machine.



B - Familiarization

Placing the machine in maintenance configuration:

- Lift scissor arms to a sufficient height to tilt the stand.
- Tilt the stand to the vertical position. A mechanical locking click sound occurs.
- The stand should remain in the vertical position.
- Lower the scissor arms.
- Scissor arm pivoting rod should rest on the V groove of the stand.



B - Familiarization

Placing the machine in the operational position (Excluding maintenance) :

- Lift scissor arms to a sufficient height to tilt the stand.
- Press the unlocking button on the maintenance stand .
- Tilt the stand to the horizontal position.
- Lower the scissor arms.



B - Familiarization

2.3 Ground control box - Service / Emergency station

2.3.1 Layout - Touch screen display









The ground control box is an emergency box. Do not use the ground control box when there are people on the platform except in case of emergency to rescue someone.

General view





B - Familiarization







Controls and indicators

Marking	Name	Description	Function
5	SA420	Platform raising / lowering selector	By pressing on  : Platform lift.
			By pressing on  : Platform descent.
6	SA905EN	Enable Switch	By pressing on Enable Switch  and simultaneously a desired function will activate a movement.
9	SB801	Emergency Stop button	Pulled out: Ground control box energized.
			Pushed in (activated): De-energizes control system.
10	HL905	Indicator, ground control box selected	LED lights up - ground control box icon.
11	SA801	Overriding system control	By pressing on  : Authorize movements from the ground control box in case of overload (Use ONLY in case of emergency) .
12	SB907	Horn button	By pressing on  : Horn activation.
13	HL906	Indicator of the platform control box selection	LED lights up - platform control box icon.
14		Beacon light on/off	By pressing on  : Beacon light ON / OFF

B - Familiarization

Marking	Name	Description	Function
15	HL908	Overload indicator / Fault	 <p>Alarm icon:</p> <ul style="list-style-type: none"> - The indicator flashes: <ul style="list-style-type: none"> • When the machine starts up, at the same time as the icon (16) • Or if overriding is active - The indicator displays a steady light: <ul style="list-style-type: none"> • If a fault is detected, an error code is displayed on the on-board screen • Or Hydraulic oil temperature icon is active on on-board screen • Or the engine pressure icon is displayed on the on-board screen • Or the engine stop icon is displayed on the on-board screen • Or the machine overload icon is displayed on the on-board screen
16	HL909	Engine warning indicator/ Engine pre-heating	 <p>Alarm icon:</p> <ul style="list-style-type: none"> - The indicator flashes: <ul style="list-style-type: none"> • When the machine starts up, at the same time as the icon (15) • Or if overriding is active - The indicator displays a steady light: <ul style="list-style-type: none"> • Engine warning icon is active on on-board screen • Or the machine tilt icon is displayed on the on-board screen • Or Engine is pre-heating <p>N.B.-:IF THE MACHINE IS NOT EQUIPPED WITH RANGE EXTENDER@, THE INDICATOR LIGHTS ARE NOT OPERATIONAL. ONLY ELECTRIC MODE IS AVAILABLE.</p>
18	SA308	Full Electric mode (If equipped with the Range Extender option)	<p>In Full Electric mode, the combustion engine never starts. Energy comes from the batteries.</p>  <p>This mode is activated by default when starting the machine.</p> <p>N.B.-:IF THE MACHINE IS NOT EQUIPPED WITH RANGE EXTENDER@, BUTTONS (18, 19 AND 20) ARE NOT OPERATIONAL. ONLY ELECTRIC MODE IS AVAILABLE.</p>

B - Familiarization

Marking	Name	Description	Function
19	SA309	Auto mode (If equipped with the Range Extender option) Refer to operator manual-  D 1.5 - Mode operation	In Auto Mode  , the combustion engine starts and stops depending on the machine's use and traction battery charge level. The combustion engine recharges the batteries.
20	SA905	Manual mode (Forced charging) (If equipped with the Range Extender option) Refer to operator manual-  D 1.5 - Mode operation	In Manual Mode  , the user starts and stops the combustion engine. The combustion engine recharges the batteries. Above 100 %, the engine stops if no movement is initiated.
21	SA900	Control box activation key switch	 : De-energizes control system.  : Platform control box energized.  : Ground control box energized.
22		Touch screen display	





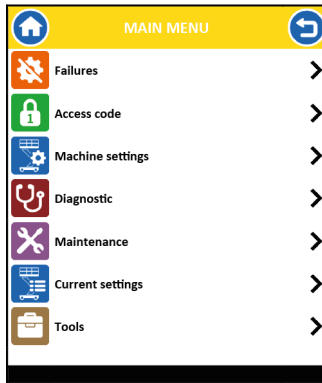

B - Familiarization

2.3.2 Touch screen display

Upon starting and during operation of the machine, the touch screen display located on the ground control box displays in real time the machine operating status.

Touch screen display







	Home Button
	Back button
	Access menu button
	Failures
	Access code
	Machine settings
	Diagnostic
	Maintenance
	Current settings
	Tools

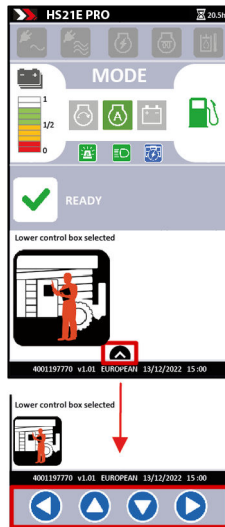







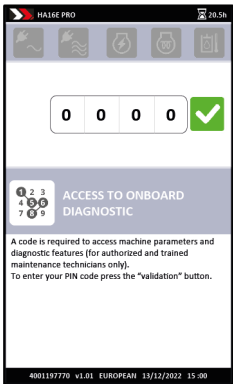

N.B.-:-PRESS YOUR FINGER ON THE TOUCH SCREEN TO NAVIGATE THROUGH THE DIFFERENT MENUS.

B - Familiarization

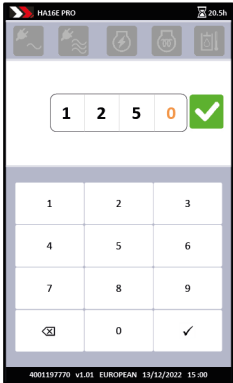
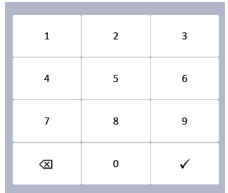

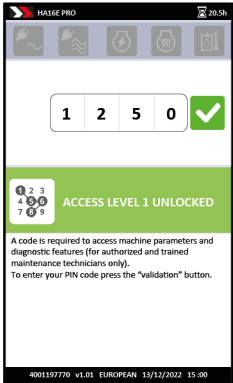

	Pressing the icon displays the navigation arrows
	Scroll left button
	Scroll up button (Scrolling is possible by sliding your finger vertically on the screen)
	Scroll down screen button (Scrolling is possible by sliding your finger vertically on the screen)
	Scroll right button

B - Familiarization

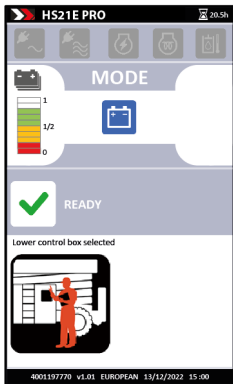
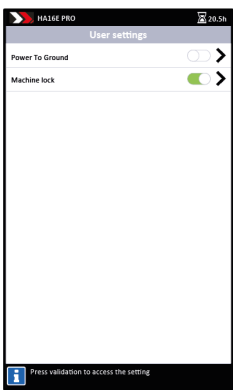

Icon	Description	Icon	Description
	<p>Access code (Will be visible - depending on the machine)</p>		Access code not yet entered
			Access code entered is correct (Level 1, 2 or 3 depending on authorization of technician)
			Access code entered is incorrect
	<p>Enter access code (Will be visible - depending on the machine)</p>		Enter the access code using the keypad (Press the touch screen)
			Validation of the access code (Press the touch screen)
	<p>Access code NIV 1 (Will be visible - depending on the machine)</p>	<p>The machine can be personalized with a user identification code. Personalization is only possible with NIV 1 : 1250 access.</p> <p>Machine properties display: Soft version, machine serial number, adjustment parameters.</p> <p>Possible change of parameters: Language, fault display format, brightness setting, time, and some options availables.</p>	
			Operator PIN code not yet entered
			Operator PIN code entered is correct
			Operator PIN code entered is incorrect

B - Familiarization



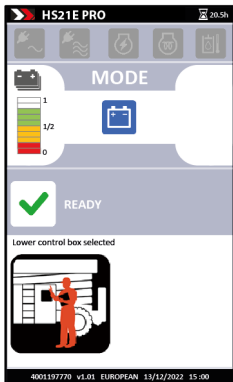
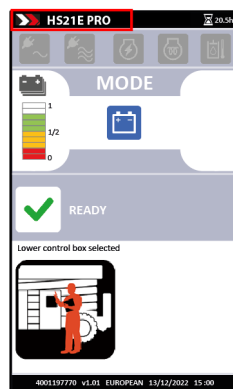

Icon	Description	Icon	Function
			
	User settings	<p>Machine lock </p> <p>Power To Ground </p>	<p>Machine movements locked by code</p> <p>Activates or deactivates the ground control box power supply</p>

Icon	Description	Icon	Description	Function
------	-------------	------	-------------	----------



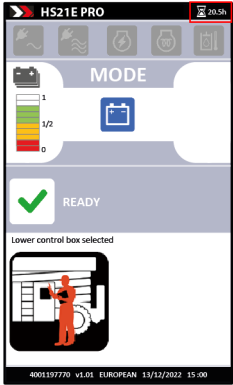



Home screen (dashboard)

				
	Machine model zone		Machine model	Machine model display

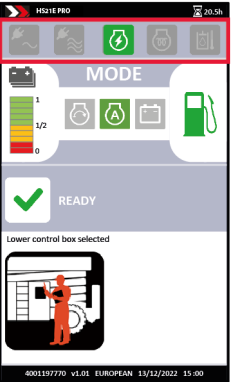
B - Familiarization

Icon	Description	Icon	Description	Function
	Hour meter/next maintenance zone		Hourmeter	The hourglass will flash if there is movement or motion of the machine.
			Maintenance use	The Maintenance Tool icon and the number of hours remaining until the next maintenance are displayed for 5 seconds when the machine is started up. Maintenance Tool icon blinks; if maintenance is due.
				The maintenance tool icon turns RED when the next scheduled maintenance must be carried out in under 25 hours





B - Familiarization

Icon	Description	Function
Home screen (dashboard)		
	Charging icons zone	
	Single-phase	The single-phase charge socket is connected to an electricity network
	Three-phase	The three-phase charge socket is connected to an electricity network
	Range Extender connection	The Range Extender is connected to the machine
	Engine preheating	Engine preheating in progress. Please wait a few seconds.
	Hydraulic oil overheating	Hydraulic oil overheating detection

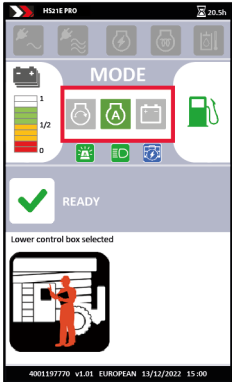

B - Familiarization

Icon	Description	Function
Home screen (dashboard)		
	Functional information zone	
	Battery charge status	Battery charge status gauge
	Charging	The machine recharges itself
	Battery accelerated recharge	The machine recharges itself
	Battery charge complete	Charge finished and complete
	Estimated remaining charge time	Estimated charging time display



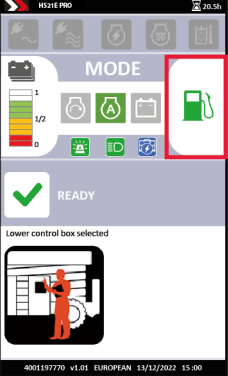

B - Familiarization

Icon	Description	Function
Home screen (dashboard)		
	Functional information zone	
	Electric mode	In electric mode, the machine will operate under battery power only. No emission
	Auto mode	In mode Auto (If equipped with the Range Extender@ option) the machine will automatically manage engine and electric inputs
	Forced engine mode (Forced charging)	In mode Manual (If equipped with the Range Extender@ option) , the machine will operate using the engine and the battery will remain charged



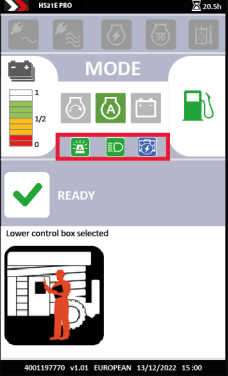

B - Familiarization

Icon	Description	Function
Home screen (dashboard)		
	<p>Functional information zone</p>	
	<p>High fuel level (If equipped with the optionRange Extender@)</p>	<p>Sufficient fuel level</p>
	<p>Low fuel level (If equipped with the optionRange Extender@)</p>	<p>Fuel level is low. Refill the fuel tank to the marked level</p>



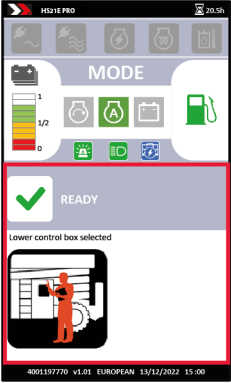



B - Familiarization

Icon	Description	Function
Home screen (dashboard)		
	<p>Additional functions (Options)</p>	
	<p>Beacon</p>	<p>The icon is ON when the flashing light is switched on</p>
	<p>Activ' Lighting System</p>	<p>The icon is ON when the Activ' Lighting System is switched on in auto or manual mode</p>
	<p>Platform supply</p>	<p>The platform power supply is on</p>

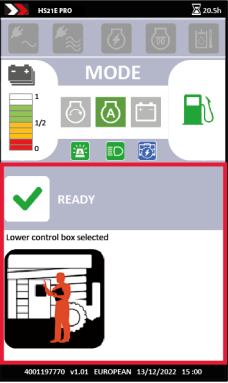





B - Familiarization

Icon	Description	Function
Home screen (dashboard)		
	Machine status zone	
	Pictogram and title	Displays the pictogram and machine status
	Ready	Machine ready, displayed when no failures and no other machine state icons is active
	Alarm	The alarm icon blinks in case of: <ul style="list-style-type: none"> - Machine failure - Failure detected - Machine overloaded - Machine on excessive slope Another icon will be displayed to show the machine's status, the failure or the malfunction

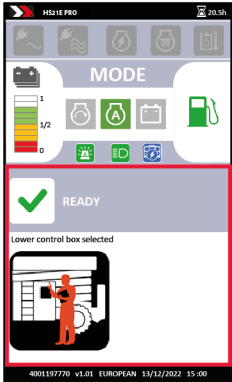

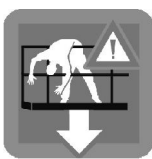
B - Familiarization

Icon	Description	Function
Home screen (dashboard)		
	Machine status zone	
	Platform control box selected	Selector switch is in platform control box position.
	Ground control selected	Selector switch is in ground control box position.
	Tilt	The machine is elevated, and is on a slope greater than the permitted slope. Depending on the machine configuration, the lifting and extension functions are slowed or stopped.
	Overload	The platform is overloaded. Remove the excessive load to or below the rated capacity, to restore functions. In case of emergency, use the Overriding system control to rescue a user on the platform.
	Machine is charging	Battery recharge (From the mains).





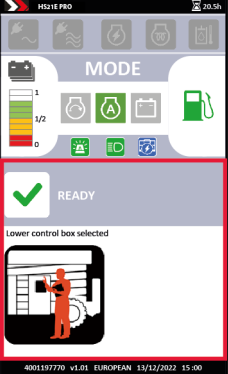

B - Familiarization

Icon	Description	Function
Home screen (dashboard)		
	Machine status zone	
	Platform control box Emergency Stop button	Emergency Stop at platform control box has been pushed in (de-energized). The machine will switch off after several seconds if the key selector (21) on the ground control box is in the  position.
	Emergency mode inactive	The Overriding system (11) command is inactive because the machine is not in overload. Use the activation command to rescue an operator who is stuck or unable to get out.
	Emergency mode active	Emergency Mode, use only to rescue trapped or incapacitated operator. Press and hold down the Overriding system control.
Home screen (dashboard)		
	Machine status zone	
	Battery level low	Recharge the battery using Auto mode or Manual mode (forced charging), or connect the equipment to a mains power supply.

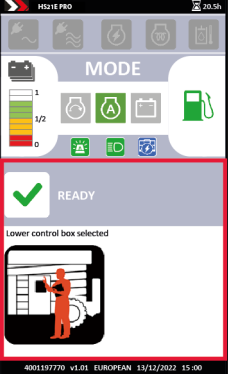



B - Familiarization

Icon	Description	Function
Home screen (dashboard)		
	Machine status zone	
	Battery standard recharge	Warning, 1 month(s) since last full recharge. 1 full recharge a month is recommended to maintain battery performance. The next recharge must be a full recharge.
	Battery standard recharge	Warning, more than 45 days since last full recharge. 1 full recharge a month is recommended to maintain battery performance. The next recharge must be a full recharge.

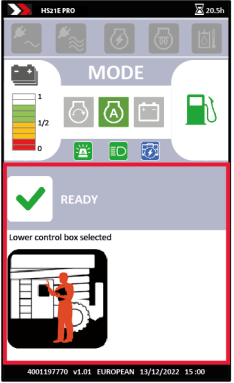

B - Familiarization

Icon	Description	Function
Home screen (dashboard)		
	Machine status zone	
	Schedule maintenance	 Refer to the Service Manual
	Drive disabled by charger	To prevent damage to the charger's charging cable, all driving movements are disabled..
	Too hot to charge	The battery temperature is too high. Charging them now would cause damage.
	Too cold to charge	The battery temperature is too low. Charging them now would cause damage.



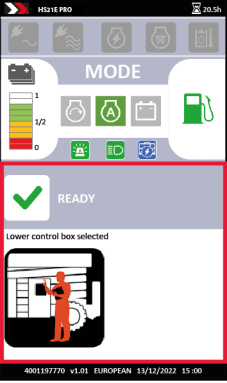
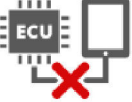

B - Familiarization

Icon	Description	Function
Home screen (dashboard)		
	Machine status zone	
	Movement restricted due to critical battery level	The battery level is critical. Battery recharge is mandatory. To continue operating, use Manual mode or Auto mode to recharge the battery.
	Range Extender disconnected	The Range Extender is disconnected. Auto and Manual modes are not available.
	Machine forced in electric mode and/or charge interrupted	Power supply from the mains socket on the platform takes priority. Battery charging is interrupted.

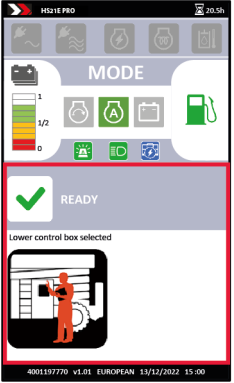

B - Familiarization

Icon	Description	Function
Home screen (dashboard) - Will be visible - depending on the machine		
	Description	
	F12.01 Bus CAN fault	CAN network fault between the screen and the rest of the machine.
	Diagnostic in progress	The HAULOTTE Diag console is connected to the machine.
	Screen software obsolete	Screen software update essential. Contact Haulotte Service®.

B - Familiarization

Icon	Description	Function
Home screen (dashboard) - Will be visible - depending on the machine		
	Description	
	Activ' Shield Bar disable	The secondary safety system is switched off (If fitted) .
	Activ' Shield Bar triggered	<p>The secondary safety system is triggered. An operator may be trapped on the platform:-</p> <ul style="list-style-type: none"> - In this situation, supervisor(s) at ground level must turn the control box key selector (21) to the ground control box  position to take control. - The platform box controls are de-energized. - Check that the Emergency Stop button (9) at ground is not pressed in. - To safely activate movements from the ground control box, the Enable Switch (6)  must be pressed and held.

B - Familiarization







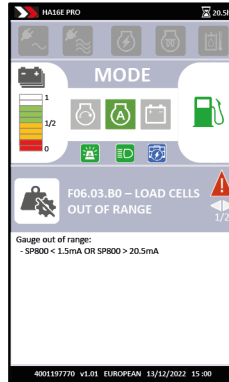

Icon	Description	Function
Home screen (dashboard) - Will be visible - depending on the machine		
	<p>General information zone</p>	
	<p>Machine software version and code</p>	<p>Displays the reference and version of the software installed on the machine.</p>
	<p>Machine date and time</p>	<p>Displays the date and time of the machine ECU.</p>

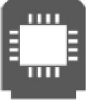
B - Familiarization

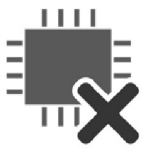









Icon	Function	Description	Icon	Function	Description
Machine fault - Will be visible - depending on the machine					

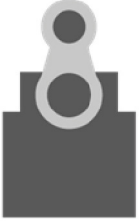

Machine fault icons (Please see machine configuration)

	Failure code F01.xx	Fault:-Variable speed calculator		Failure code F11.xx	Fault:-Machine safety
	Failure code F02.xx	Fault:-Power contactor		Failure code F12.xx	Fault:-ECU console
	Failure code F03.xx	Fault:-Command relay		Failure code F13.xx	Fault:-Switchs
	Failure code F04.xx	Fault:-Solenoid valve			
	Failure code F05.xx	Fault:-Joystick		Failure code F15.xx	Fault:-CAN circuit

B - Familiarization

Icon	Function	Description	Icon	Function	Description
Machine fault - Will be visible - depending on the machine					
	Failure code F06.xx	Fault:-Weighing system		Failure code F16.xx	Fault:-Electric motor
	Failure code F07.xx	Fault:-Limit switch or sensor		Failure code F17.xx	Fault:-Pump motor
	Failure code F08.xx	Fault:-Electric circuit		Failure code F18.xx	Fault:-Generator
	Failure code F09.xx	Fault:-Internal combustion engine		Failure code F19.xx	Fault:-Telematics
	Failure code F10.xx	Fault:-Functions		Failure code F20.xx	Fault:-Battery

2.4 Platform control box - Main station

2.4.1 Layout

N.B.:-DISPLAY OF THE CONTROLS ON THE CONTROL BOX DEPENDS ON THE CONFIGURATION AND STATUS OF YOUR MACHINE.

B - Familiarization

General view-HS21 E (HS6395 E) - HS21 E PRO (HS6395 E PRO)

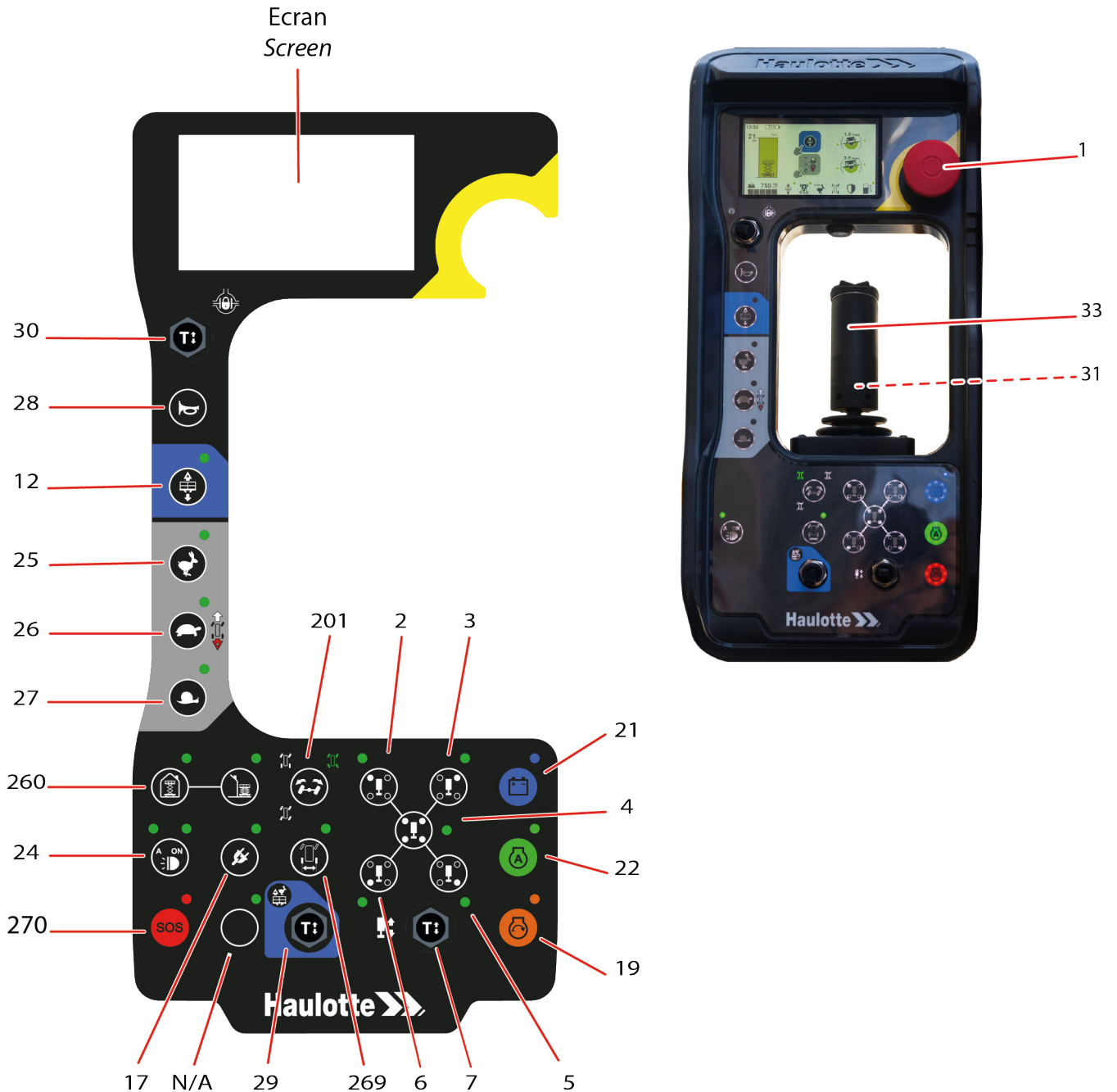

N.B.-:FOR MULTI-FUNCTION CONTROLS, SUCCESSIVELY PRESSING THE CONTROL SWITCHES FROM ONE FUNCTION TO ANOTHER

N.B.-:THE GREEN INDICATORS ON THE CONTROL BOX ARE ON WHEN THE FUNCTIONS REQUESTED ARE ACTIVE.

FOR NUMBERS (2, 3, 4, 5) AND (6):



- **SLOW FLASHING: STABILIZER SELECTED**
- **RAPID FLASHING: STABILIZER EXTENDED BUT NOT SET**
- **CONSTANTLY ON: STABILIZER SET**

FOR NUMBERS (19, 21) AND (22):





- **THE INDICATORS ARE THE COLOR OF THE PICTOGRAM**

B - Familiarization



Controls and indicators

Marking	Name	Description	Function
1	SB802	Emergency Stop button	Pulled out: Platform control box power supply energized
			Pushed in: De-energizes control system
2	SA121	Front left-hand stabilizer extension/retraction control	Press the control to extend the stabilizer Press the control to retract the stabilizer
3	SA124	Front right-hand stabilizer extension/retraction control	Press the control to extend the stabilizer Press the control to retract the stabilizer
4	SA120	Centralized stabilizer extension/retraction control	Press the control to extend the stabilizers Press the control to retract the stabilizers
5	SA123	Rear right-hand stabilizer extension/retraction control	Press the control to extend the stabilizer Press the control to retract the stabilizer
6	SA122	Rear left-hand stabilizer extension/retraction control	Press the control to extend the stabilizer Press the control to retract the stabilizer
7	XXXX	Central stabilizer extension/retraction selector	Press and hold down the selector after choosing the stabilizer to be extended Press and hold down the selector after choosing the stabilizer to be retracted
12	SA400	Platform raising / lowering selector	Pressed down (activated and LED on): Platform raising/lowering selection
17	SA906	Platform electric power supply control (For machines equipped with it)	Pressed down (activated) : Platform supply
19	SA303	Manual mode (Forced charging) (If equipped with the Range Extender@ option)	In Manual Mode  , the user starts and stops the combustion engine. The combustion engine recharges the batteries. At 100 % the engine stops and switches to electric mode.
21	SA306	Full Electric mode	Energy comes from the batteries. This All Electric  mode is activated by default when the machine starts up.

B - Familiarization

Marking	Name	Description	Function
22	SA307	Auto mode (If equipped with the Range Extender@ option)	In Auto  mode, the Range Extender starts and stops depending on the machine's use and the battery's charging status. The range extender recharges the batteries.
24	SA910	Activ' Lighting System selector	 ON (Manual)
			 Automatic lighting
			 OFF (Manual)
25	SA110	High-speed drive control	Pressed down (indicator on) : High-speed drive selection
26	SA111	Medium-speed drive control	Pressed down (indicator on) : Medium speed drive selection
27	SA112	Low-speed drive control	Pressed down (indicator on) : Low-speed drive selection
28	SA907	Horn button	Press in and hold: Horn activation.
29	XXXX	Full speed lifting control	Press in and hold (Activated) : Full speed lifting activation (if fitted)
30	SA100	Differential lock selector	Press in and hold (Activated) : Differential lock activation
			The machine automatically slows down for differential lock engagement then the speed is limited to low speed.
31	SM901 EN	Enable Switch	Press in and hold (Activated) : Joystick movements activated
33	SM900N	Drive joystick	Move forward (Push) : Driving following the white arrow
			Move backwards (Pull) : Driving following the red arrow
		Steering rocker switch	Press right side of button: Wheels turn to the right
			Press left side of button: Wheels turn to the left
		Lifting joystick	Move forward (Push) : Lowering
			Move backwards (Pull) : Lifting

B - Familiarization

Marking	Name	Description	Function
201	SA101	Steering mode selector	 : 2 front steered wheels
	SA101SY		 : Synchronised steering: 4 wheel steering mode (Only for PRO model)
	SA101CR		 : 4 steered wheels in crab steering mode (Only for PRO model)
269	SA151	Rear wheel alignment control (For PRO machine only)	Pressed down: Activation of automatic rear wheel alignment - Indicator not illuminated: Wheels not aligned - Flashing green indicator: Alignment in progress - Steady green indicator light: Wheels aligned
270	XXXX	SOS selector (Not used)	Pressed down: Continuous operation of the lower buzzers and beacon
N/A	N/A	Not used	Not used

2.4.2 Screen

N.B.-:DISPLAY OF THE PICTOGRAMS ON THE SCREEN OF THE PLATFORM CONTROL BOX DEPENDS ON THE CONFIGURATION AND STATUS OF YOUR MACHINE.

General view-HS21 E (HS6395 E) - HS21 E PRO (HS6395 E PRO)

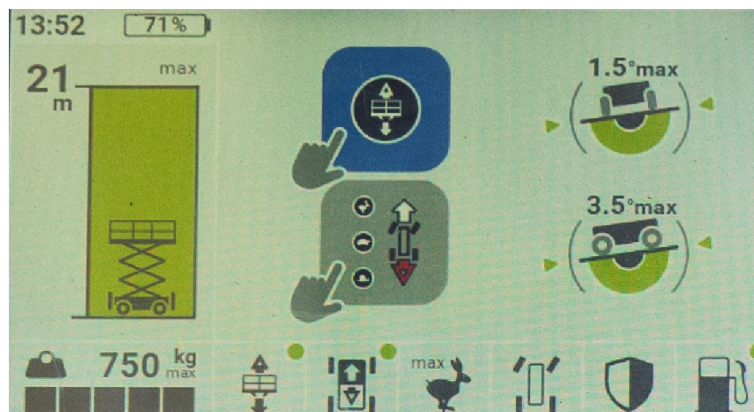

B - Familiarization

Details-HS21 E (HS6395 E) - HS21 E PRO (HS6395 E PRO)

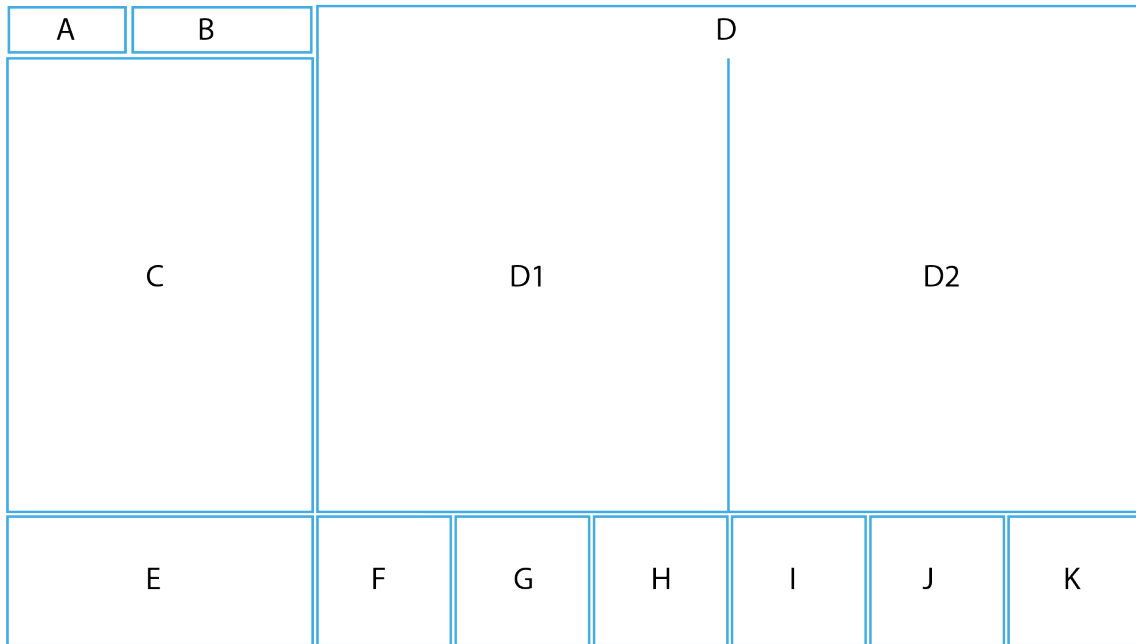









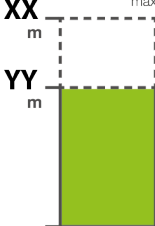

Description





Mark	Description
A	Hours/minutes display
B	Battery charge level display
C	Working area/range of motion display
D (D1 - D2)	Information and instructions zone: <ul style="list-style-type: none"> - No outline: Normal operation in progress - Orange outline: Instructions to be carried out for optimal operation - Red outline: Prohibitions / Major fault
E	Indicator showing platform load capacity in real time
From F to K	Status bar <ul style="list-style-type: none"> - Movement availability - Status of the options on the machine - Power source - ...

B - Familiarization





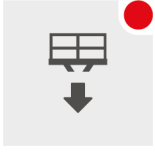
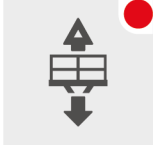
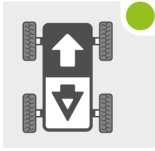
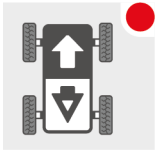

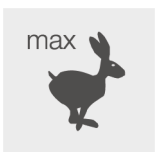
Description of the zones

Mark	Icon	Description
		Start-up screen
A	00:00	Hours/minutes display
B	Battery charge	Lithium battery
		Battery charge status
C	Working area / Range of motion	
		Unrestricted
		Restricted
D	Information and instructions zone	Refer to the table: Information and instructions zone
E	Load capacity	
		Load < 10%
		10% ≤ Charge < 20%
		20% ≤ Charge < 40%
		40% ≤ Charge < 60%
		60% ≤ Charge < 80%
		80% ≤ Charge
		Overload
F	Elevation	

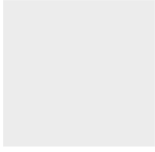
B - Familiarization





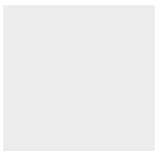

Mark	Icon	Description
		Movement allowed
		Lifting not permitted
		Lowering not permitted
		Movement is not permitted
G	Driving	
		Drive authorised
		Driving not permitted
H	Max speed	
		Maximum micro speed authorized
		Maximum low speed authorized
		Maximum high speed authorized
I	Activ' Shield Bar - Operator protection	

B - Familiarization

Mark	Icon	Description
		System absent
		System not activated
		System activated
		The user requests a movement but the platform control box is not in its holder. Movement is slowed down.
		Detection of a crushing movement by the Activ' Shield Bar during a movement
J	Not used	
K	Power source	
		Sufficient fuel level
		Low fuel level
		Range Extender@ not connected

B - Familiarization

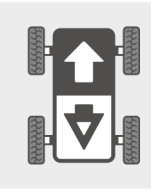

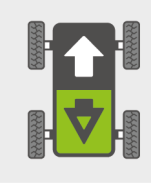

Information and instructions zone

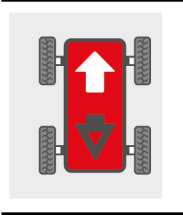
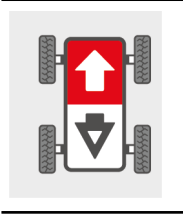
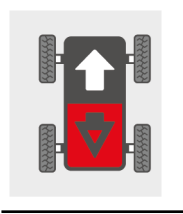
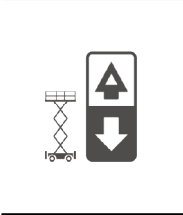
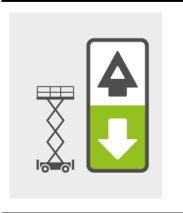
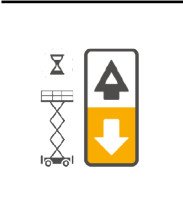
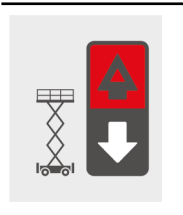
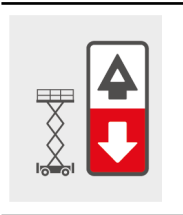
Mark / Icon	Description
D (D1 - D2)	Information and instructions zone: - No outline: Normal operation in progress - Orange outline: Instructions to be carried out for optimal operation - Red outline: Prohibitions / Major fault
D1	- To inform about the machine's operational state - To provide guidance in case of difficulties
D2	Instructions to inform the user of the state of their machine and help them in case of difficulty or critical situations
	Select the lifting mode (Up / Down)
	Select the driving mode
	Select the stabilizer mode
	Realign the rear wheels
	Supply power to the basket outlet
	Driving mode selected
	Driving following white arrow in progress
	Driving following red arrow (on the machine) in progress





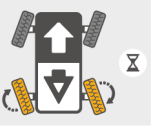

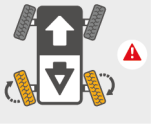
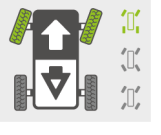
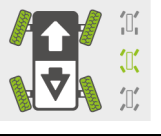
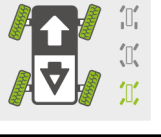
B - Familiarization

Mark / Icon	Description
	<p>Drive movement prohibited</p> <p><i>N.B.: THE SCREEN PROVIDES DRIVING ASSISTANCE. THE MACHINE'S DRIVING DIRECTION IS INDICATED BY THE RED AND WHITE ARROWS ON THE CHASSIS.</i></p>
	<p>Movement in the white arrow direction is forbidden</p>
	<p>Movement in the red arrow (on the machine) direction is forbidden</p>
	<p>Lifting movement in progress</p>
	<p>Lowering movement in progress</p>
	<p>Lowering movement paused</p>
	<p>Lifting movement prohibited</p>
	<p>Lowering movement prohibited</p>

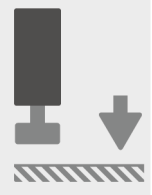
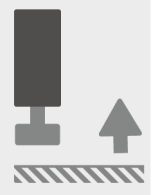
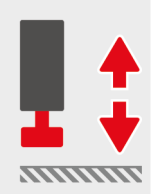







B - Familiarization

Mark / Icon	Description
	Lower platform again to perform requested action
	Platform lowering performed
	Maximum authorized platform height reached
	Wheel realignment in progress on the red arrow side of the chassis
	Realignment of the wheels on the red arrow side of the chassis is complete
	Wheels on the red arrow side of the chassis not aligned
	2 wheel steering mode selected
	4 steered wheels mode selected
	Crab steering mode selected

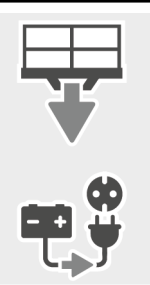
B - Familiarization

Mark / Icon	Description
	Stabilizer lowering requested
	Stabilizer lifting requested
	Stabilizer movement prohibited
	 Indicates a hazardous situation which if not avoided, WILL result in death or serious injury
	Platform control box is not selected
	Lowering request on ground control box
	User too close to platform control box (if fitted)
	Request to user to move away from the platform control box (if fitted)







B - Familiarization

Mark / Icon	Description
	User too far away from platform control box (if fitted)
	Ask the user to move closer and/or position themselves in front of the upper control panel (if fitted)
	Place the control box into the Activ' Shield Bar Scissors® support (if fitted)
	Lower the platform then connect the machine to the mains power supply
	Lower the platform before plugging the machine into the power supply or starting the Range Extender®
	 Check that the folding zone is unobstructed
	Select the platform control box from the ground control panel (Service / Emergency station)
	Joystick not functioning



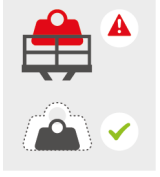

B - Familiarization

Mark / Icon	Description
	Press the activation control
	Press the Foot Switch
	Disconnect the mains plug
	Push the high-speed lifting selector
	Activ' Shield Bar Scissors® not functioning
	Clean the user protection system sensor
	Differential lock active
	Differential lock automatically activated
	Differential locking system not available

B - Familiarization

Mark / Icon	Description
	<p>Geofence: Geolocated usage restriction. Return to the authorized area</p>
	<p>Timefence: Authorisation for use according to defined time slots</p>
	<p>Restricted-use machine: Contact the owner of the machine</p>
	<p>User identification required</p>
	<p>Tracker offline and/or faulty</p>
	<p>Reduce the load on board</p>
	<p>Lower part of platform in contact. Lift platform</p>

B - Familiarization

Mark / Icon	Description
	Machine operating within the allowed side slope range
	Machine outside the permitted lateral slope range
	Machine operating within the allowed front-to-back slope range
	Machine operating beyond the allowed front-to-back slope range
	Machine unfolded and tilted

B - Familiarization

3 Performance Specifications

3.1 Technical characteristics

Use the table to select the right Haulotte machine for the job.



Do not replace parts that are essential to the stability of the machine, such as batteries or tyres, with parts that have a different weight or different specifications. The stability of the machine could be affected.

CE, UKCA, AS, EAC, CSA and ANSI A92.20 standards

Machine	HS21 / HS6395	
	E	E PRO
Characteristics - Dimensions		
Total weight with wide platform + 2 extensions	10 620 kg (23,413 lbs)	10 750 kg (23,700 lbs)
Folded length with wide platform + 2 extensions (Extensions retracted)	4,96 m (14 ft 6 in)	
Unfolded length with wide platform + 2 extensions (Extensions extended)	7,51 m (24 ft 8 in)	
Width	2,43 m (8 ft)	
Maximum side rated slope - On wheels	1,5°	
Maximum side rated slope - On stabilizers	1°	
Maximum longitudinal rated slope	3,5°	
Maximum ground pressure of wheel on paved ground - On wheels	12,9 daN/cm ²	
Maximum ground pressure of wheel on paved ground - On stabilizers	11,4 daN/cm ²	
Maximum load on wheel	5770 kg (12720 lbs)	
Outside turning radius - Extension retracted	7,45 m (24 ft 5 in)	4,40 m (14 ft 5 in)
Inside turning radius	4,05 m (13 ft 3 in)	2,7 m (8 ft 10 in)
Maximum working height	21,2 m (69 ft 7 in)	
Maximum platform height (On stabilizers)	19,5 m (64 ft 0 in)	

B - Familiarization

Machine	HS21 / HS6395	
	E	E PRO
Maximum platform height (On wheels)	19,20 m (63 ft 0 in)	
Overall height of the machine in folded / stowed position (Folding guardrails option)	2,720 m (8 ft 11 in)	
Maximum horizontal reach (With wide platform + 2 extensions)	4,255 m (14 ft 00 in)	
Maximum outreach above the ground (With wide platform + 2 extensions)	3,755 m (12 ft 4 in)	
Maximum platform capacity	750 kg (1,650 lbs)	
Maximum extension deck capacity	225 kg (495 lbs)	
Maximum number of occupants	4	
Maximum number of person on extension (refer to the maximal capacity on extension)	2	
Maximum wind speed	45 km/h (12,5 m/s) - 28 mph (41 ft/s)	
Manual force	400 N (90 lbf)	
Gradeability	38 %	
Drive speed: - Micro-speed - Slow speed - Medium speed - High speed	- 0,8 km/h (0.5 mph) - 1,5 km/h (0.93 mph) - 3 km/h (1.86 mph) - 4,5 km/h (2.8 mph)	
Maximum freewheel speed during towed operation	1,5 km/h (0.93 mph)	

Specifications - Performance

Operating temperature	From - 20°C to + 50°C (From - 4°F to + 122°F)
Storage temperature	From - 30°C to + 60°C (From - 22°F to + 158°F)

B - Familiarization

Machine		HS21 / HS6395			
		E		E PRO	
Maximum operating altitude		4000 m (13123 ft 4.315 in)			
Nominal power		22 kW			
Power source - Electric					
Standard	Option	Battery weight	System voltage	Capacity	Capacity
X		200 kg (440 lb)	77 V 2 38,4 V modules	280 A.h	280 A.h

B - Familiarization

3.2 Working area / Range of motion

HS21 E (HS6395 E) - HS21 E PRO (HS6395 E PRO)

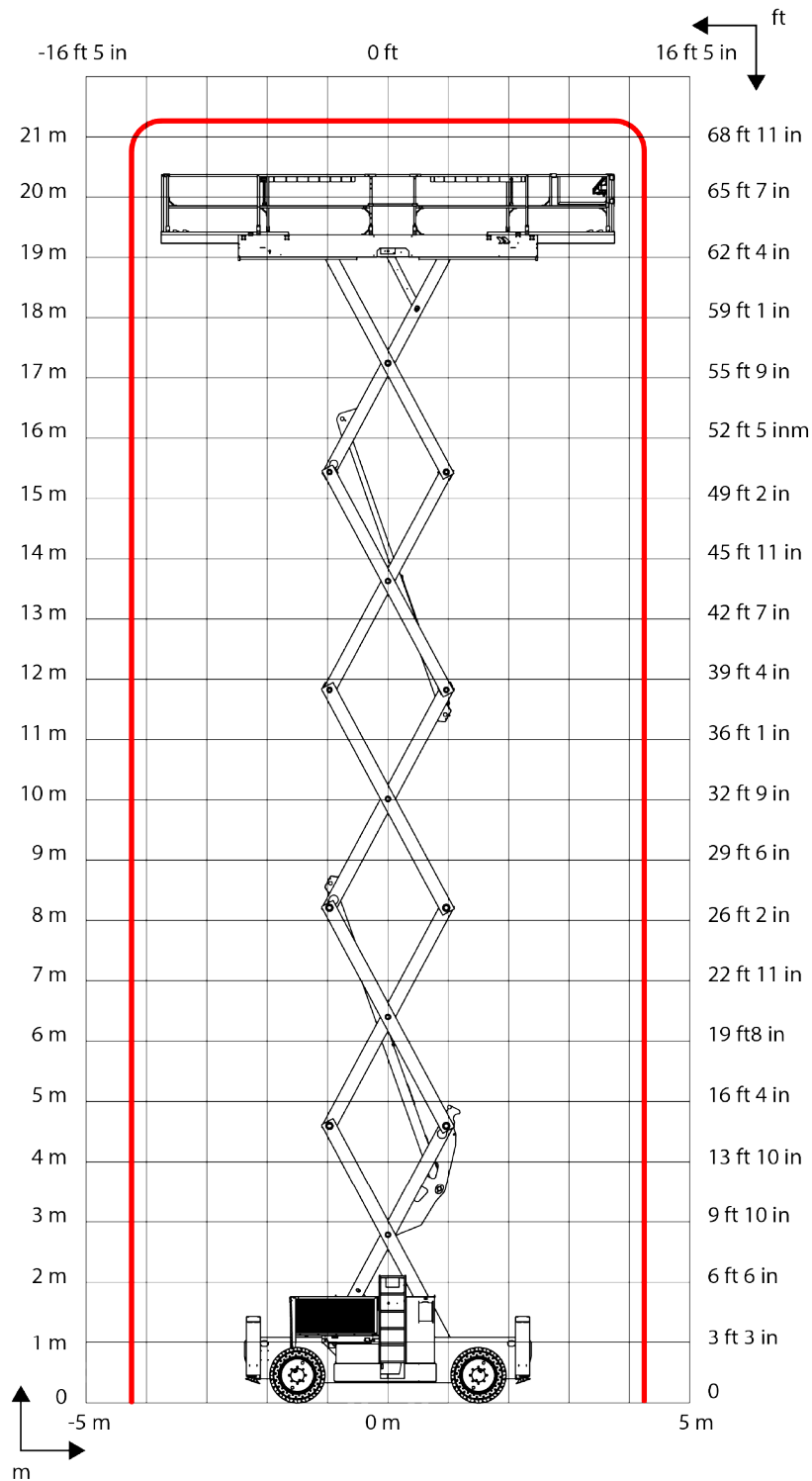

4 Decals and markings locations

CE, UKCA, AS and EAC standards: HS21 E - HS21 E PRO

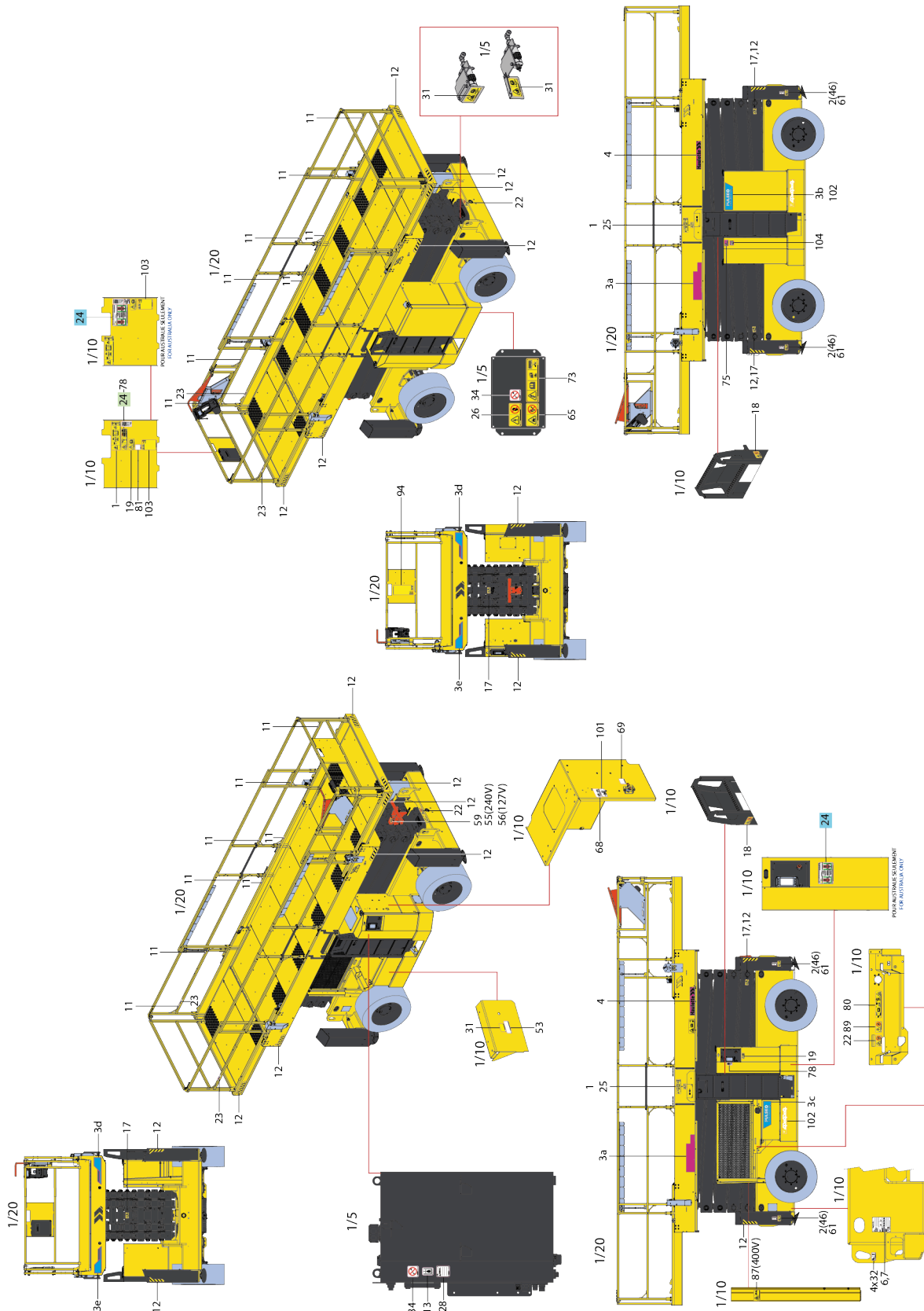

B - Familiarization

CE, UKCA, AS and EAC standards: HS21 E - HS21 E PRO

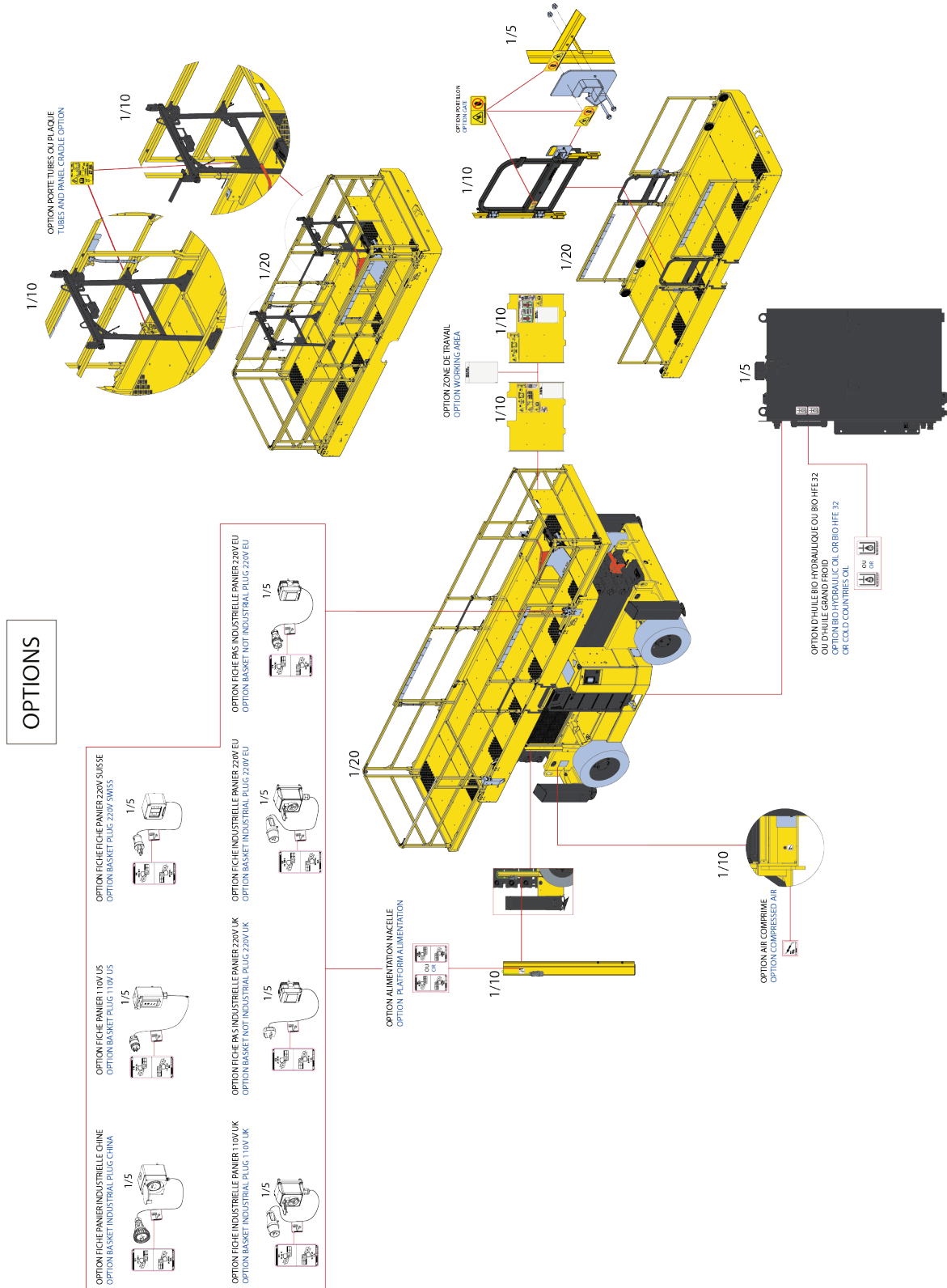

B - Familiarization

CE, UKCA, AS and EAC standards: HS21 E - HS21 E PRO

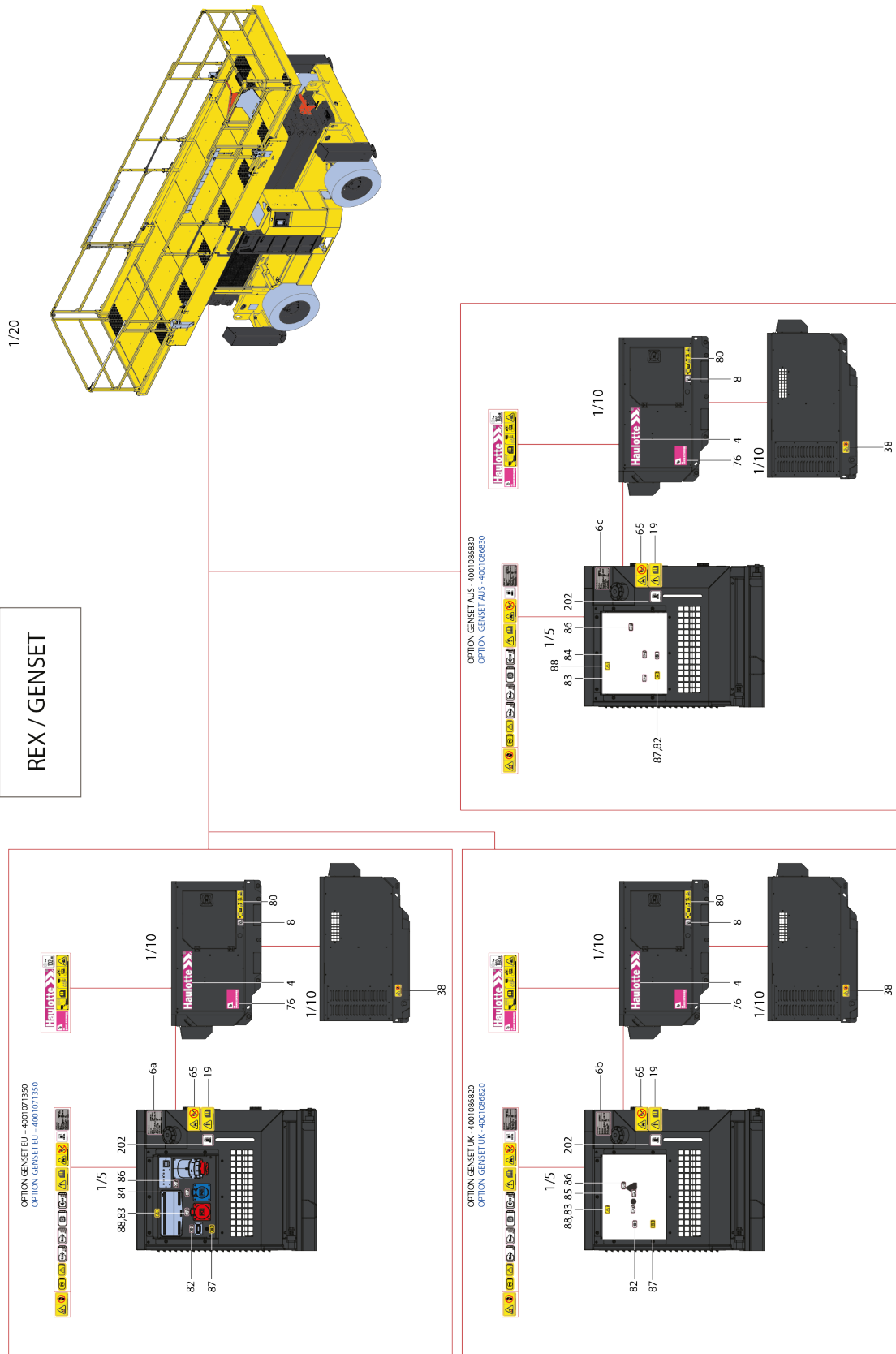

B - Familiarization

CE, UKCA, AS and EAC standards: HS21 E - HS21 E PRO

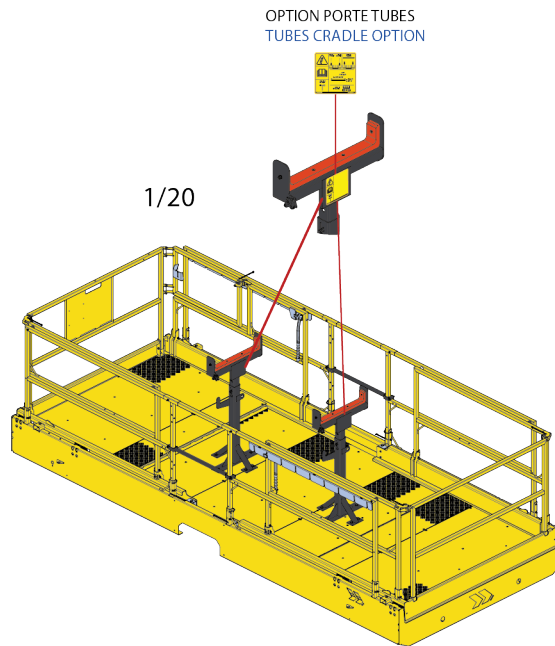
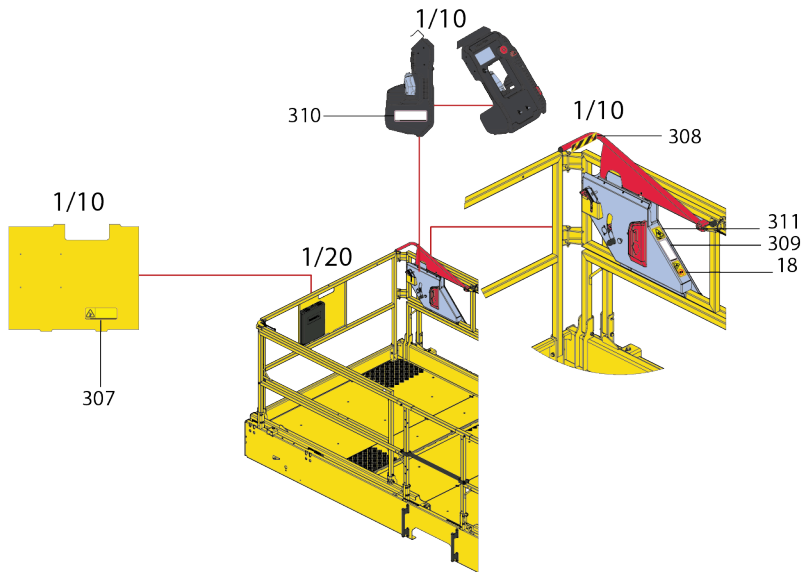

B - Familiarization**CE, UKCA, AS and EAC standards: HS21 E - HS21 E PRO**

Marking	Description	Quantity	HS21 E	HS21 E PRO
1	Height of the floor and load	3	4001320760	4001320760
2(46)	Pressure-Stress on the floor+Maximum effort on the stabilizers+Transport height	4	4001325080	4001325080
3a	Commercial name-HS21E / HS6395E LIGHT	2	4001310270	N/A
3a	Commercial name-HS21E / HS46395E DARK	2	4001320280	N/A
3a	Commercial name-HS21E PRO / HS6395E PRO LIGHT	2	N/A	4001320290
3a	Commercial name-HS21E PRO / HS6395E PRO LIGHT	2	N/A	4001320300
3b	Decal PULSEO GENERATION-Left	1	40010722270	
3c	Decal PULSEO GENERATION-Right	1	40010722280	
3d	Decal PULSEO GENERATION-Left platform	2	40010722290	
3e	Decal PULSEO GENERATION-Right platform	2	4001072300	
4	Decal HAULOTTE®-495 X 80-Bright machine	2	4001072210	
4	Decal HAULOTTE®-495 X 80-Dark machine	2	4001072220	
11	Lanyard attachment points	16	4001052020	
12	Yellow and black adhesive tape	8	4001052030	
13	Hydraulic oil	1	4001052050	
17	Risk of crushing	5	4001052070	
18	Hand crushing hazard-Risk of crushed hands	2	4001052080	
19	Read the operation manual	2	4001052090	
22	Wound foot	1	4001073700	
23	Driving direction	2	4001052110	
24	Danger of electrocution	1	For CE and EAC standards only: 4001052120	
24	Danger of electrocution	2	AS standard only: 4001052140	
25	Closing drop rail	2	4001052150	

B - Familiarization

Marking	Description	Quantity	HS21 E	HS21 E PRO
26	Ground for welding	1	4001052160	
28	Software version	1	4000504670	
31	Brake release	3	4001073710	
32	Anchorage point-Traction	4	4001052180	
34	Do not high-pressure wash	2	4001052200	
53	Emergency lowering	1	4001367600	
55	240 V charger socket	1	4001110960	
56	127 V charger socket	1	4001110970	
59	Scissors safety	1	4001052240	
61	Risk of crushed feet	4	4001052260	
65	Danger of fire	1	4001052270	
68	Transport height	1	4001325090	4001325090
69	Circuit breaker	1	4001366680	
73	Battery mass	1	4001366990	
75	Battery management-Bright machine	1	4001053460	
75	Battery management-Bright machine	1	4001053510	
78	QR Code ( https://www.e-technical-information.com)	2	4001281820	
80	Assembly procedure- Range Extender	1	4001074890	
81	Control unit position	1	4001367130	
87	400V 16A charger socket	1	4001134700	
89	Do not store	1	4001074880	
94	Guardrail order of folding	1	4001318480	
101	Gradeability	1	4001366980	
102	4 drive and steer wheels - Bright machine	2	N/A	4001367820
102	4 drive and steer wheels - Dark machine	2	N/A	4001362340
103	Folding guardrails	1	4001366870	

B - Familiarization

Marking	Description	Quantity	HS21 E	HS21 E PRO
104	Li-ION battery - Bright machine	1	4001247630	
104	Li-ION battery - Dark machine	1	4001247640	
4	Range Extender	1	4001072220	
6		1	4001128580 / 4001128590 / 4001128600	
8		1	4001068990	
19		1	4001052090	
38		1	4001075820	
76		1	4001072970	
80		1	4001074890	
83		1	4001075850 / 4001075860	
84		1	4001075870	
85		1	4001075880	
86		1	4001128990	
91		1	4001075830	
92		1	4001075840	
202		1	4001076200	
18		Option ActivShield Bar Scissors	1	4001052080
307	1		4001085530	
308	1		4001085540	
309	1		4001085550	
310	1		4001085560	
311	1		4001098550	
Not illustrated	Biodegradable hydraulic oil option	1	4001052380	
Not illustrated	Biodegradable hydraulic oil option- Cold country	1	4001052390	
Not illustrated	Compressed air option	1	4001052370	

B - Familiarization

ANSI and CSA standards: HS6395 E - HS6395 E PRO

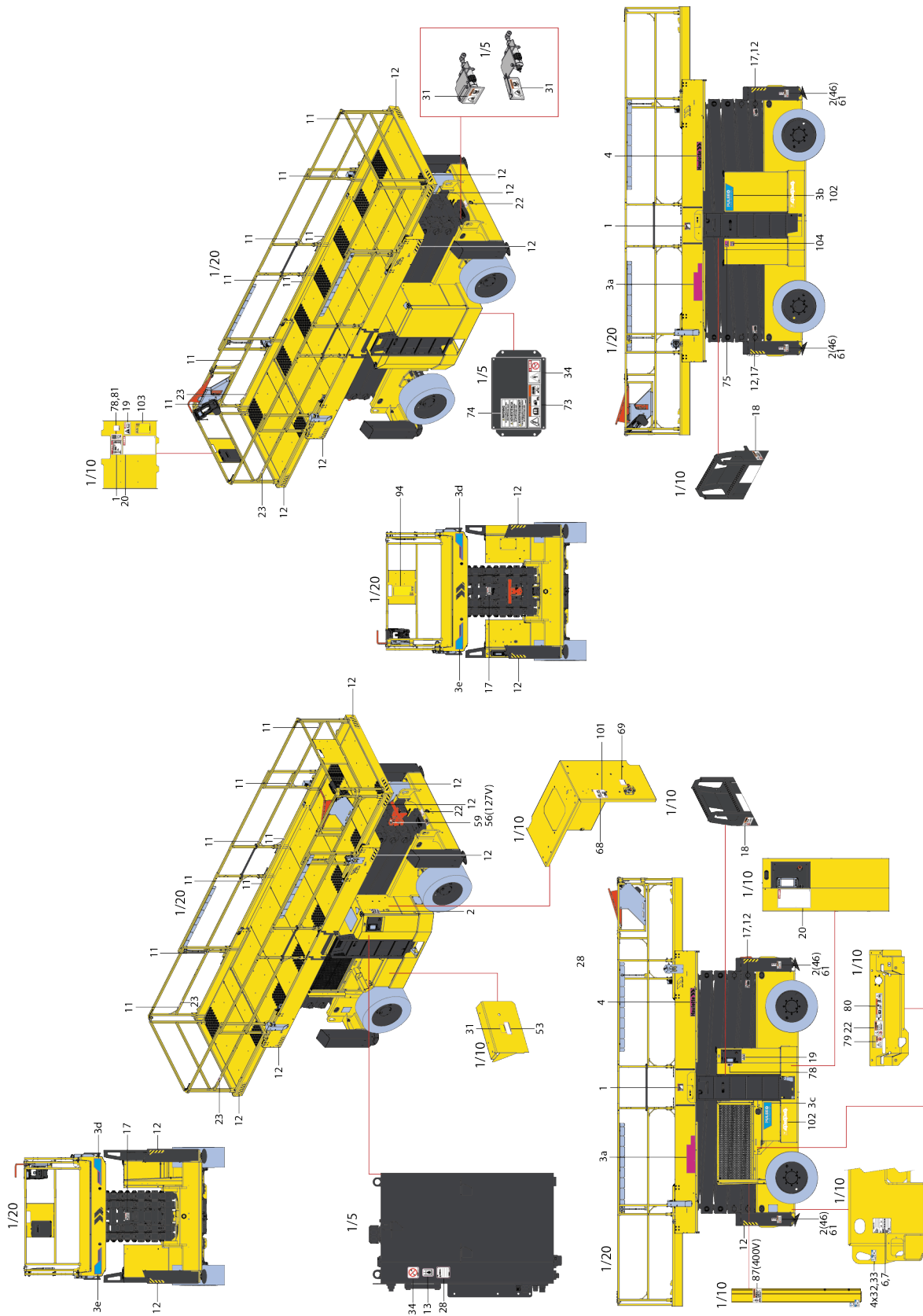

B - Familiarization

ANSI and CSA standards: HS6395 E - HS6395 E PRO

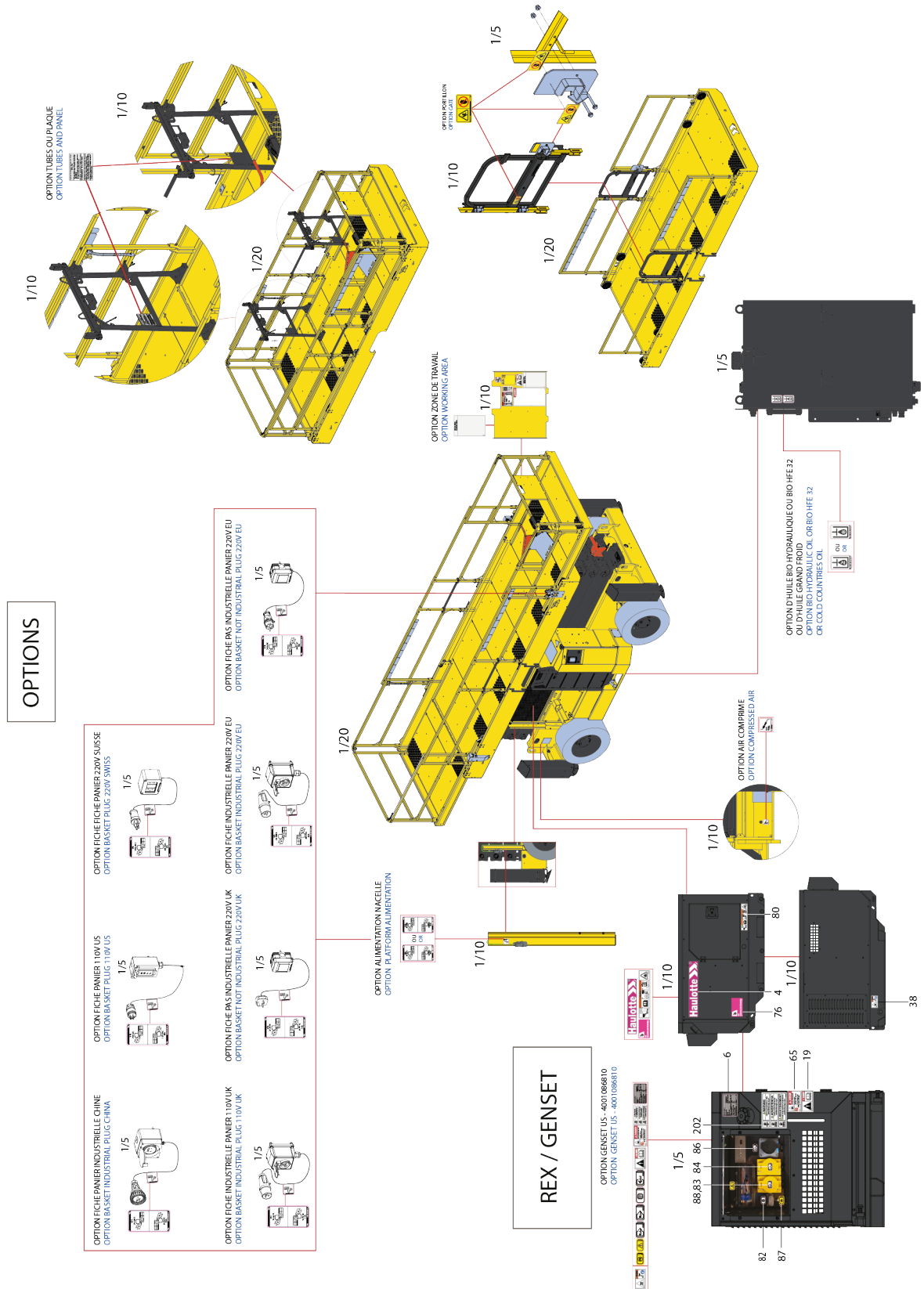

B - Familiarization

ANSI and CSA standards: HS6395 E - HS6395 E PRO

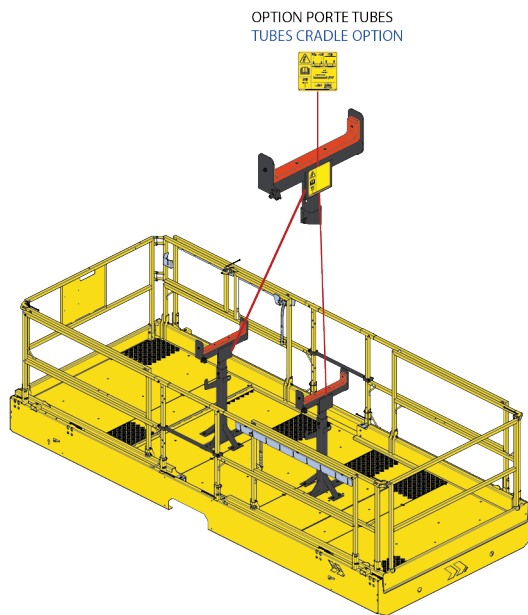
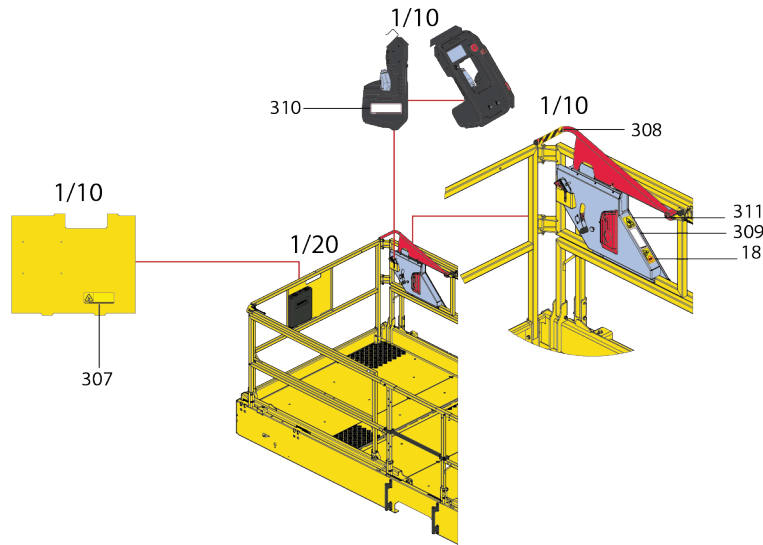

B - Familiarization

ANSI and CSA standards: HS4390 E - HS4390 E PRO - HS5390 E - HS5390 E PRO

Marking	Description	Quantity	HS6395 E	HS6395 E PRO
1	Height of the floor and load	3	4001320770	4001320770
2(46)	Pressure-Stress on the floor+Maximum effort on the stabilizers+Transport height	4	4001325080	4001325080
3a	Commercial name-HS21E / HS6395E LIGHT	2	4001320310	N/A
3a	Commercial name-HS21E / HS46395E DARK	2	4001320320	N/A
3a	Commercial name-HS21E PRO / HS6395E PRO LIGHT	2	N/A	4001320330
3a	Commercial name-HS21E PRO / HS6395E PRO LIGHT	2	N/A	4001320340
3b	Decal PULSEO GENERATION-Left	1	40010722270	
3c	Decal PULSEO GENERATION-Right	1	40010722280	
3d	Decal PULSEO GENERATION-Left platform	2	40010722290	
3e	Decal PULSEO GENERATION-Right platform	2	4001072300	
4	Decal HAULOTTE®-495 X 80-Bright machine	2	4001072210	
4	Decal HAULOTTE®-495 X 80-Dark machine	2	4001072220	
11	Lanyard attachment points	16	4001052020	
12	Yellow and black adhesive tape	8	4001052030	
13	Hydraulic oil	1	4001052050	
17	Risk of crushing	5	4000024640	
18	Hand crushing hazard-Risk of crushed hands	2	In english: 4000024640 In french: 400024770 In spanish: 4000086490	
19	Read the operation manual	2	4000025140	
22	Wound foot	1	4000027570	
23	Driving direction	2	4000024840	
28	Software version	1	4000504670	
31	Brake release	3	4001133750	

B - Familiarization

Marking	Description	Quantity	HS6395 E	HS6395 E PRO
32	Anchorage point-Traction	4	4000027310	
33	Elevation	4	4000027330	
34	Do not high-pressure wash	2	4000025130	
53	Emergency lowering	1	4001367600	
56	127 V charger socket	1	4001134690	
59	Scissors safety	1	In english: 4000024850 In french: 4000068070 In spanish: 4000086500	
61	Risk of crushed feet	4	In english: 4000024780 In french: 4000067700 In spanish: 4000086480	
68	Transport height	1	40001325090	40001325090
69	Circuit breaker	1	4001366680	
73	Battery mass	1	4001367010	
74	Ground control box	1	4001026850	
75	Battery management-Bright machine	1	4001053460	
75	Battery management-Bright machine	1	4001053510	
78	QR Code ( https://www.e-technical-information.com)	2	4001281820	
80	Assembly procedure- Range Extender	1	4001128970	
81	Control unit position	1	4001367130	
88	240 V 25 A charger socket	1	4001134710	
89	Do not store	1	4001134640	
94	Guardrail order of folding	1	4001318480	
101	Gradeability	1	4001366980	
102	4 drive and steer wheels - Bright machine	2	N/A	4001367820
102	4 drive and steer wheels - Dark machine	2	N/A	4001362340
103	Folding guardrails	1	4001366870	

B - Familiarization

Marking	Description	Quantity	HS6395 E	HS6395 E PRO
104	Li-ION battery - Bright machine	1	4001247630	
104	Li-ION battery - Dark machine	1	4001247640	
4	Range Extender	1	4001072220	
6		1	4001128610	
19		1	400025140	
38		1	400027450	
76		1	4001072970	
80		1	4001128970	
83		1	4001129050	
84		1	4001129060	
85		1	4001075880	
86		1	4001128990	
91		1	4001075830	
92		1	4001129040	
202		1	4001126880	
18		Option Activ'Shield Bar Scissors	1	4001052080
307	1		4001085530	
308	1		4001085540	
309	1		4001085550	
310	1		4001085560	
311	1		4001098550	
Not illustrated	Biodegradable hydraulic oil option	1	4001052380	
Not illustrated	Biodegradable hydraulic oil option- Cold country	1	4001052390	
Not illustrated	Compressed air option	1	4001052370	

C - Pre-operation inspection

1	Recommendations.....	3
2	Working area assessment.....	4
3	Inspection and Functional test.....	5
3.1	Daily inspection.....	5
4	Safety functional checks.....	9
4.1	Emergency Stop button check.....	9
4.2	Activation of controls.....	9
4.3	Fault detector.....	10
4.4	Automatic engine cut-out (If machine equipped with the option Range Extender) ...	11
4.5	Overload sensing system.....	11
4.6	Slope warning device.....	11
4.7	Machine braking.....	12
4.8	Travel speed limitation.....	12
4.9	On-board electronics.....	13
4.10	Anti-crush system when lowering.....	13
4.11	Braking test.....	13
4.12	Overload test.....	14

C - Pre-operation inspection

1 Recommendations

The owner, the site manager, the supervisor and the operator are all responsible to ensure the machine is fit for the work it is to perform; i.e. that the machine is suitable to carry out the work in complete safety and in compliance with this Operator's Manual. All managers who are responsible for persons operating the machine must be familiar with the local regulations currently applicable in the country of use and ensure that they are adhered to.

Before using the machine, read the previous chapters in this manual. Ensure that you have understood the following points:

- Safety precautions.
- Operator's responsibilities.
- Conditions and the operating principles of the machine.

C - Pre-operation inspection

2 Working area assessment

Before carrying out any operations, ensure that the machine corresponds to the work to be done and the working environment:

- Carry out a thorough inspection of the site to identify any potential risks within the work zone.
- Take the necessary precautions to avoid collisions with other machinery or people within the work area.
- Mark out the work area.
- **Ensure that:**
 - The weather conditions (wind, rain, etc.) allowing the machine to be used.
 - The ground withstands the weight of the machine and has not been affected by the poor weather conditions.
- Check that the authorisations to work with the machine on the site in question have been obtained (.g. chemical product factories).
- Define a rescue plan for all the risks, including the risk of falls and crushing.

C - Pre-operation inspection

3 Inspection and Functional test

3.1 Daily inspection

Each day before the beginning of a new work session and with each change of operator, the machine must be subjected to a visual inspection and a complete functional test.



- Never use a defective or a malfunctioning aerial work platform.
- If any item on the check list is marked "No" during the inspection; machine must be tagged and placed out of service.
- Do not operate the machine until all identified items are corrected and it has been declared safe for operation.

In case of loose fasteners, refer to torque table value in maintenance book.

In case of leaks, replace the damaged part before use.

In case of structural part deformation (cracks, broken weld, paint chips) replace the part before use.



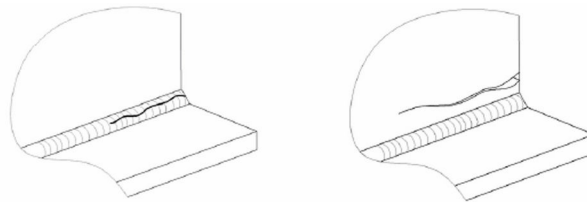





Examples of cracked welds



We recommend these forms to be completed daily and stored to assist with your maintenance schedule.

Each action is depicted in the daily inspection sheet using the following symbols.















Use the detailed program below.

	Oil change		Lubrication-Lubrication		Tightening
	Levelling		Systematic replacement		Functional adjustments / Checks / Cleaning
	Visual inspection		To check by test		







Serial number: Hours of operation: HAULOTTE Services® contract reference: Intervention record number: Date: Name:	Model: Signature:
--	----------------------

C - Pre-operation inspection









HS21E - HS6395E - HS21E PRO - HS6395E PRO

	Daily	OK	NOK	Corrected	Comments
Chassis assembly: Wheel, reducer, steering, wheel pivot					
Check state of tires/tyres and inflations					
Clean the pads slide					
Check the pads: Tightening,Attendance					
Check that there are no leaks on the stabilizer cylinders					
Inspect the brake release solenoid valve cover					
Range extender (if equipped)					
Check engine fuel level (Top up the oil if necessary)					
Check engine oil level (Top up the oil if necessary)					
No leaks from engine components (engine, hoses ...)					
Check the condition of the battery					
Batteries					
Check the condition of the battery					
Hydraulic : oils, filters and hoses					
Check the hydraulic oil level (Top up the oil if necessary ; Machine stowed)					
Check the clogging indicator on the hydraulic pressure filter (change if clogged)					
Check the hoses, blocks and pumps, fittings, cylinders and the tank for the absence of leaks, deformations and damage					











C - Pre-operation inspection

Haulotte 	Daily	OK	NOK	Corrected	Comments
Platform					
Ensure that the door or sliding bar automatically returns to the closed and locked position					
Check that the harness anchor points are not cracked or damaged					
Check guide rollers and external stops					
Clean the platform extension					
Check the quick ties and the good location of the guardrail					

HS21E - HS6395E - HS21E PRO - HS6395E PRO

Haulotte 	Daily	OK	NOK	Corrected	Comments
General					
Check for the presence, cleanliness and readability of the manufacturer's plates, security labels, user manual and maintenance manual					
Check the cleanliness and readability of the control box					
Test the opening and locking of the covers					
Check the condition of electrical harnesses, cables and connectors					
Check for the absence of abnormal noise and jerky movements					
Check for the absence of visible deterioration and damage					
Check for the absence of cracks, broken welds and chipped paintwork on the structure					

C - Pre-operation inspection

Haulotte 	Daily	OK	NOK	Corrected	Comments
Check for the absence of missing or loose screws and bolts					
Check for the absence of deformation, cracking and breakage of axis stops, bushing and axes					
Check for the absence of foreign bodies in joints and sliding parts					
Safety devices					
Test the operation of the upper and lower control boxes: manipulators, switches, buttons, horn, emergency stops, screens and lights					
Check the absence of visual and audible alarms					
Test the operation of the tilt system					
Test the operation of the emergency lowering system					
Check the operation of the overload indicator					
Test the operation of the Activ Shield Bar (If equipped)					

C - Pre-operation inspection

4 Safety functional checks

To protect the user and the machine, safety systems prevent the movement of the machine beyond its operating limits. These safety systems when activated immobilize the machine and prevent further movement.

The operator must be familiar with this technology and understand that is not a malfunction but an indication that the machine has reached an operation limit.

The aerial work platforms are fitted with a platform control box (main control box) and a ground control box (emergency control box) enabling users to use the machine safely. An auxiliary system (Overriding system) is available on the ground control box in order to rescue anyone trapped on the platform.

The following checks describe the operation of the machine and the specific controls required.



For the location and description of these controls: refer to section B 2.3 and D 2 - Ground control box and B 2.4 and D 3 - Platform control box.

4.1 Emergency Stop button check

Machine switched on:

Ground control box Emergency Stop button

Step	Action
1	Pull the Emergency Stop button (9) at the ground control box.
2	Set the key switch (21) at ground box to the  position.
3	The indicator (10) lights up on ground control box.
4	Push the Emergency Stop button (9).
5	Check that the screen turns off.
6	Check no movements are functional.

Platform control box Emergency Stop button

Step	Action
1	Pull both Emergency Stop buttons (9) at ground box and (1) at platform box.
2	Set the key switch (21) at ground box to the  position.
3	The indicator (13) lights up on ground control box.
4	Push in Emergency Stop button (1) at platform.
5	Check no movements are functional. The indicators go out.

4.2 Activation of controls

The enable switch must be active to allow any movement.

The "Enable Switch" system depends on the machine configuration and will consist of one of the following:

- Joystick trigger (31) on the platform control box.
- Foot pedal (enable switch) in the platform (Optional)

C - Pre-operation inspection

- Activation control on (6) on ground control box.

N.B.:-THE ENABLE SWITCH MUST BE ACTIVATED FIRST BEFORE ANY ACTION ON THE JOYSTICK OR SWITCHES.

4.3 Fault detector

The machine is equipped with an on-board fault detection system, which indicates the type of fault to the operator.

The fault is identified by a default code.

The default code is displayed at the ground control box.

The fault code is indicated by a red triangle on the platform control box screen.

According to the type of fault, the machine MAY switch into DOWNGRADEMODE mode and certain movements are prevented to maintain Operator's safety.

Do not use the machine until the fault has been corrected.

4.3.1 Indicators/LED's test

From the ground control box

Step	Action
1	Pull the Emergency Stop button (9) at the ground control box.
2	Set the key switch (21) at ground box to the  position
3	Check that the LEDs (10, 13, 15, 16) and that the touch screen (22) light up.
4	Check that the LED's (13, 15, 16) on the display are all turned off after 1 sec.

N.B.:-THE INDICATORS ON THE PLATFORM CONTROL BOX DEPEND ON THE CONFIGURATION OF YOUR MACHINE

From the platform control box

Step	Action
1	Pull the Emergency Stop button (9) at the ground control box.
2	Set the key switch (21) at ground box to the  position
3	Check that the indicators (13, 15, 16) and the screen (22) of the ground control box light up.
4	First push in the Emergency Stop button (1) at platform box, then pull out.
5	Check that the indicators and the screen of the platform control box light up.

C - Pre-operation inspection

4.3.2 Buzzers test

From the ground control box

Step	Action
1	Pull the Emergency Stop button (9) at the ground control box.
2	Set the key switch (21) at ground box to the  position.
3	Verify that the buzzers at the ground and platform beep.

4.4 Automatic engine cut-out (If machine equipped with the option Range Extender)

If the machine is in Forced Mode  (Forced charging) , the engine automatically cuts out in the following conditions:

- The alternator is not functioning.
- Engine temperature is too high.
- Oil pressure is too low.
- The Emergency Stop(s) is (are) pushed in.
- The machine is switched off.
- The battery is 100% charged.

N.B.-:WHEN THE MACHINE IS 100% CHARGED, THE MACHINE SWITCHES BACK TO FULL ELECTRIC

MODE  .



4.5 Overload sensing system

If the platform load exceeds the maximum allowed load, no movement is possible from the 2 control boxes. At ground and platform control boxes a buzzer sounds and an indicator light warns the operator.

To return the machine to normal operation remove weight from the platform until the load is below the maximum allowed load.

Daily check that the LED's illuminate when the machine is switched on:

- Verify that the Overload system is active: Refer to the indicator (15) on the ground control box and the screen on the platform control box (Zone E) .
- Verify that the buzzers are functioning: Refer to  Buzzers test.

A periodic inspection of this device must be performed according to the recommendation in  C.3 -Maintenance Schedule +  C.4.12 -Overload test.

4.6 Slope warning device

From each control box, a buzzer alerts the operator that the machine is not folded/stowed and is positioned on a slope exceeding the slope allowed.

N.B.-:THE SLOPE SENSOR IS ONLY ACTIVE WHEN THE PLATFORM IS NOT IN THE STOWED POSITION.

When the machine is on a slope greater than the maximum authorized slope and if the machine is elevated:



- The DRIVE and LIFTING (RAISING) commands are prohibited.
- The lowering speeds are reduced.

C - Pre-operation inspection

In this case, fully lower the platform and reposition the machine on level ground before raising the platform again.



Perform the following steps to check the tilt sensor operation:

To check the tilt sensor at ground level

Step	Action
1	Put the machine in stowed position.
2	Position the machine on an incline that is greater than the maximum permitted incline ( B 3.1 - Technical specifications) .
3	Check that the tilt indicators  and/or  are displayed in red (On the screen of the platform control box) .
4	Unfold the machine. Ensure the movement is stopped.
5	Buzzers at ground and platform will beep.

4.7 Machine braking

Platform control box

Step	Action
1	Put the machine in stowed position.
2	Pull both Emergency Stop buttons; (9) at ground box and (1) at platform box.
3	Set the key switch (21) at ground box to the  position.
4	Select low drive speed (27)  , then slowly move the drive joystick.
5	Release joystick. Ensure that the machine stops immediately and does not drift.

4.8 Travel speed limitation



This system does not release the user from their responsibility to adapt their driving to their knowledge of the machine and its environment.

The machine has a selector of 3 driving speeds - low, medium and high.

All driving speeds are authorised when the machine is folded, (machine in transport position).

Maximum translational speeds are disabled during upward movement once the elevation height below is reached:

Machine	Maximum platform height before driving speed restriction	
	Mètre	Feet
HS21E (HS6395E)	< 2,90 m	< 9 ft 6 in
HS21E PRO (HS6395 PRO)	< 2,90 m	< 9 ft 6 in

C - Pre-operation inspection

When not in transport position and depending on the machine's maximum height before travel speed is restricted, micro and nano speeds are automatically engaged.

The electronic variable speed unit controls movement and driving speed.

It receives information from the control joystick concerning the movements to be performed.

It also manages the safety systems status.

Poor knowledge of the characteristics and operation of the machine can lead the operator to think that a normal safety operation is a malfunction.

On a slope, the speed decreases automatically.

If the slope exceeds 25%, the machine must be fully folded..



In certain extreme temperature conditions, the machine's driving performances may be reduced.

4.9 On-board electronics

The machine is equipped with a specific calculator configured for this machine's functionalities.

Do not interchange calculators between machines, as this may result in the loss of parameters, settings, calibrations, and render the machine inoperable.

4.10 Anti-crush system when lowering

A device alerts people on the ground of a risk of crushing:

- Between the lifting systems.
- Under platform extension.

This device automatically operates between the transport height position limit and the lower position (Refer to Driving speed) .

All versions, lowering control from the platform and ground control boxes:

- Slows the downward movement and emits an audible signal.

Standards CE and EAC, lowering movement from platform control box:

- At the end of the lowering operation, a 3 (second) automatic delay is initiated before resuming lowering, to avoid the risk of crushing.

4.11 Braking test



Check that there are no hazards in the test area:

- Position the machine on a flat and firm surface, clear of obstructions (beware of power lines).
- The machine must be completely stowed.
- Ensure that there is sufficient distance to stop the machine in complete safety.
- Position the steered wheels so that they are straight.
- To set up a beaconing of safety around the test area.
- Personal fall protection equipment (PFPE) is compulsory to carry out this test.

C - Pre-operation inspection

Platform control box

Step	Action
1	Pull both Emergency Stop buttons; at ground box and at platform box.
2	Turn the ground control box selector key to platform control box position.
3	Select low drive speed , then slowly move the drive joystick.
4	Drive the machine forward in low speed on a ramp inclined at less than the maximum authorized slope.
5	Release joystick.
6	The machine comes to a complete stop. Keep the machine immobilized for 5 seconds.
7	Check the ability of the brakes to keep the machine immobilized. The machine must remain immobile.

4.12 Overload test





N.B.-:

THE OVERLOAD SYSTEM IS AN ESSENTIAL PART OF MACHINE SAFETY. THE TEST MUST BE CARRIED OUT BEFORE THE SALE/RESALE OF THE MACHINE AND/OR AT LEAST ONCE A YEAR.



SECTION MAINTENANCE - PLEASE REFER TO PARAGRAPH PERIODIC INSPECTION.

You will need:

 <ul style="list-style-type: none"> - Personal protective equipment - DO NOT OPERATE tag - Standard tool kit - Lifting equipment adapted and suitable for placing and removing the load from the platform - 2 loads of 100% and 120% of the nominal load: Refer to section B  - Technical specifications. 	 <ul style="list-style-type: none"> - Place barriers around the perimeter of the work area 		
	1 person		

Procedure:

Platform control box

Step	Action
1	Position the machine on a flat and firm surface, clear of obstructions (beware of power lines).
2	Start the machine.
3	Put the machine in stowed position.
4	Mark out the work area (barriers, cones, marking tape) .
5	Restrict access to the area (restricted access sign).

C - Pre-operation inspection

Step	Action
6	Place a do not operate tag at the start/stop switch location to inform personnel that the equipment is being worked on.
7	Use external lifting equipment to position 100% of the nominal load in the center of the platform.
8	From the ground control box: Check that there is no overload alarm.
9	Remove the weight from the platform.
10	Use external lifting equipment to position 120% of the nominal load in the center of the platform.
11	Check that the overload/fault indicators are lighted on the 2 control boxes.
12	Check that the overload alarms are displayed on the screens of the 2 control boxes.
13	Remove the load from the platform.

D - Operation instructions

1	Operation.....	3
1.1	Introduction.....	3
1.2	Major description.....	3
1.3	Operation from the ground control box (Service / Emergency station)	3
1.4	Operation from the platform control box (Main station)	4
1.5	Mode operation.....	4
2	Ground control box - Service / Emergency station.....	6
2.1	To start and stop the machine.....	6
2.2	Movement control.....	6
2.3	Additional controls.....	6
3	Platform control box - Main station.....	7
3.1	To start and stop the machine.....	7
3.2	Drive and steer control.....	7
3.3	Movement control.....	10
3.4	Additional controls.....	10
4	Rescue and emergency procedures.....	11
4.1	In case of power loss.....	11
4.2	To rescue operator in platform.....	11
4.3	No power available.....	12
5	Transportation.....	16
5.1	Transport configuration.....	16
5.2	Machine stowage for transport.....	17
5.3	Loading by ramp.....	17
5.4	Folding guardrails.....	18
5.5	Unloading.....	28
5.6	Towing.....	28
5.7	Storage.....	32
5.8	Lifting operation.....	35
6	Cold Weather Recommendations.....	38
6.1	Hydraulic oil.....	38
6.2	Li-ion battery.....	38
7	Battery care and maintenance (For machines equipped with the lithium-ion battery option)	39
7.1	Battery recharge.....	39
7.2	Optimise battery life.....	41

D - Operation instructions

1 Operation

1.1 Introduction

Only trained and authorized personnel shall be permitted to operate this aerial work platform.

Prior to operation:

- Read, understand and obey all instructions and safety precautions in this manual and attached to the aerial work platform.
- Read, understand and obey all local regulations.
- Become familiar with the proper use of all controls and emergency systems.

1.2 Major description

All the machines are equipped with:

- Platform control box.
- Ground control box.



- An Emergency Stop button is present at each control box.
- The Emergency Stop button at the ground control box stops all movements when pressed in.
- The Emergency Stop button at the platform control box stops all movements when pressed in and the platform control box is selected. The Emergency Stop button at the platform control box is neutralized when the ground control box is selected.

1.3 Operation from the ground control box (Service / Emergency station)

The ground control box is designed for maintenance and emergency rescue operations only.

- Turning "ON" and "OFF" of the machine is performed with the Control box activation key switch (21).
- Activation of a desired control box is achieved by turning the Control box activation key switch (21) to



the desired position

- The ground control box is energized and is active ONLY when:
 - The emergency stop on the ground control box is not pushed in.
 - The machine is switched on.
 - Ground control box is selected.
- An Enable Switch (6) provided must be activated and maintained to authorize one or more function movements. If Enable Switch (6) is kept engaged without selecting a function movement for more than 8 s; Enable Switch is automatically de-activated.

N.B.:-THE ENABLE SWITCH (6) MUST BE ACTIVATED FIRST BEFORE ANY ACTION ON THE JOYSTICK OR SWITCHES.

- Drive and steer movements are not possible from the ground control box.
- All switches and joystick operating a movement, return automatically to neutral when released.
- Overriding system: The ground control box is an auxiliary control box to use in emergencies only. Refer to  D 4.2 - To rescue operator in platform.
- The status of the switches is tested automatically when the machine is switched on. A switch will be active only after it has been detected to be in neutral position. The following switches are not controlled:
 - Beacon light (if fitted)
- Engine speed (If fitted) : This switch increases the engine rpm to the maximum speed.
- A buzzer beeps in the following conditions:
 - When power is switched on.
 - Overload.
 - Anti-crushing device
 - Slope if machine is out of stowed position.
 - Hydraulic oil overheating.

D - Operation instructions

- Movement buzzer option.
- Drive buzzer option.
- Indicators: All indicators are checked after powering on the machine

1.4 Operation from the platform control box (Main station)

- The platform control box can only be used if:
 - The Emergency Stop buttons on both ground and platform control boxes are not pressed in.
 - Platform control box selected from ground control box.
- A faulty joystick is not taken into account to control a movement. If this fault disappears, the movement is authorised again.

N.B.-:THE ENABLE SWITCH (31) MUST BE ACTIVATED FIRST BEFORE ANY ACTION ON THE JOYSTICK OR SWITCHES.

- The release of "Enable switch" (31) while performing a movement stops all the movements. The stop of movements is progressive. It could restart only when the selected function switch/joystick is released to neutral position.
- All switches and joystick operating a movement, return automatically to neutral when released.
- The status of the switches and joysticks is tested automatically when the machine is switched on. A switch or joystick will be active only after it has been detected in neutral position.
- A buzzer beeps in the following conditions:
 - When power is switched on.
 - Overload.
 - Slope if machine is out of stowed position.
 - Hydraulic oil overheating.
 - Anti-crushing system active.
 - Movement buzzer option.
 - Drive buzzer option.
- Indicators: All indicators are checked after powering on the machine.

1.5 Mode operation

1.5.1 Full Electric mode (If machine equipped with the option Range Extender)

When the machine is powered up, it will be in Full Electric Mode  by default (Powered by battery and Range Extender off (if equipped with Range Extender)).

When the battery has less than 20 % charge, the following movements are disabled:

- Platform lifting.
- Extending the stabilisers.

If the batteries are fully discharged (0%) , no movement is allowed. Recharging the batteries, either connected to the mains or when starting the Range Extender, is mandatory (Refer to  D 7 - Battery care and maintenance)

The machine's main power supply can only be switched off from the ground control box by turning the

control box activation key selector (21) to OFF .

1.5.2 Auto mode (If machine equipped with the option Range Extender)

In this mode , the engine will automatically start or stop. The level of charge in the batteries is managed to optimize their life by minimizing energy consumption with the use of the thermal engine. Thereby, machine's performance level is maintained.

D - Operation instructions

The thermal engine will start

- If the battery charge status is less than 70 % and stops at 80 %.

N.B.-:-DRIVING AND / OR STEERING IS CONSIDERED A MOVEMENT.

- If the batteries are fully discharged (0%) , no movement is allowed.

N.B.-:-RECHARGING THE BATTERIES, EITHER CONNECTED TO THE MAINS OR WHEN STARTING THE ENGINE, IS MANDATORY (REFER TO  D 7 - BATTERY CARE AND MAINTENANCE) .

The machine's power supply can only be turned OFF from the ground control box by turning the control box

activation key selector (21) to the OFF  position.

If there is a fault in the Range Extender, the machine switches automatically to Full Electric mode.

1.5.3 Forced engine mode (If machine equipped with the option Range Extender)

This mode  can be selected any time.

The Range Extender will produce current to recharge the batteries up to the 100%.

The motor stops automatically when battery recharging is complete.

When the battery has less than 20 % charge, the following movements are disabled:

- Platform lifting.
- Extending the stabilisers.
- If the batteries are fully discharged (0%) , no movement is allowed. Recharging the batteries, either connected to the mains or when starting the engine, is mandatory (Refer to  D 7 - Battery care and maintenance) .

If there is a fault in the Range Extender, the machine switches automatically to Full Electric mode.

D - Operation instructions

2 Ground control box - Service / Emergency station

2.1 To start and stop the machine

- Check that the Emergency Stop buttons (9) at ground control box and (1) at platform control box are not pressed in.

- Turn the control box selector (21) to position  to energize the ground control box.

If the activation key selector for the control box (21) is activated, the machine is in Full Electric mode by default. Refer to the section on operating modes  D.1.5 Mode operation

To shut-down the machine from the ground control box:

- Turn the activation selector key switch (21) to off position .
- Power supply is now switched off.

N.B.-:THIS OPERATION TURNS OFF THE POWER SUPPLY TO MACHINE AND IT IS REQUIRED TO PREVENT BATTERY DISCHARGE.

2.2 Movement control





Even at low movement speeds, use the controls with caution.

N.B.-:RELEASING THE ENABLE SWITCH WILL STOP ALL MOVEMENTS.

N.B.-:THE ENABLE SWITCH (6) MUST BE ACTIVATED FIRST BEFORE ANY ACTION ON THE JOYSTICK OR SWITCHES.

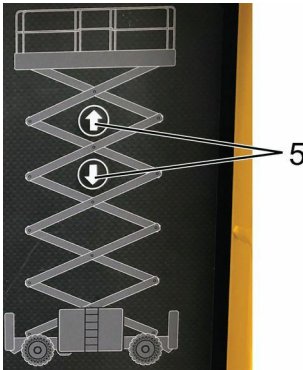
Ground control box - Service / Emergency station

Command		Action
Platform raising / lowering		Push the platform raising / lowering selector (5) upwards to raise the platform.
		Press the platform raising / lowering selector (5) downwards to lower the platform.
		Note: To activate these movements, the activation command  must be pressed and held simultaneously.

2.3 Additional controls

For the machines equipped with flashing light:

- Press the beacon control (14) to switch ON the beacon.
- Press the beacon control (14) to switch OFF the beacon.

D - Operation instructions

3 Platform control box - Main station

3.1 To start and stop the machine

3.1.1 To start the machine

At the ground control box:

- Check that the Emergency Stop button (9) is not pressed in.

- Turn the control box activation key selector (21) to platform control box position  to switch on the platform control box.

At the platform control box:

- Check that the Emergency Stop button (1) is not pressed in.
- The indicators , controls and the screen of the platform control box light up.

If the activation key selector for the control box (21) is activated, the machine is in Full Electric mode by default. Refer to the section on operating modes:  D.1.5 -Mode operation.

3.1.2 To stop the engine

The engine stops and the machine returns to Full Electric mode if:

- In MANUEL (19) mode or AUTO (22) mode, the control (21) on the platform control box is activated.

The machine's power supply can only be turned OFF from the ground control box by turning the control box activation key selector (21) to the OFF  position (Mode operation) .

3.2 Drive and steer control



Before moving, locate the white and red directional arrows on the chassis and the platform control box.

To select the Drive/Steering function, choose the movement speed (25, 26, 27). Select the steering mode (201). Push the joystick (33) and the Enable Switch (31) to perform the movements (Except for stabilizing movements) .











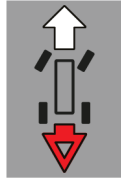

Move the drive control joystick (33) in the direction matching the directional arrows.

N.B.:-THE ENABLE SWITCH (31) MUST BE ACTIVATED FIRST BEFORE ANY ACTION ON THE JOYSTICK OR SWITCHES.



Do not use simultaneously the differential lock control (30) and the steering control. Do not activate the differential lock control (30) in the event of strong grip (dry tar, etc.). Differential lock control can only be activated if low travel speed is selected .

D - Operation instructions

Command		Action
Steering		Press the joystick rocker switch (33) left or right with your thumb to steer the wheels.
Steering mode selection		2 front steering wheels from axle
		Synchronized axle: 4 wheel steering mode
		Crab mode axle
Driving		Push the joystick (33) forward to move the machine forward, in the direction of the WHITE arrow
		Pull the joystick (33) backwards to move the machine in the direction of the RED arrow
Drive speed		Press the control (25) for high-speed driving  .
		Press the control (26) for medium-speed driving  .
		Press the control (27) for low-speed driving  (Uneven ground, short distance, final approach, tilt and to cross a slope) .
Rear wheel alignment		Press the control (269) to automatically align the rear wheels





N.B.-:-RELEASING THE ENABLE SWITCH (31) AND/OR DRIVE JOYSTICK (33) STOPS THE MOVEMENT.



Do not operate on surfaces that do not support force exerted by the outriggers during aerial work platform operation.

D - Operation instructions

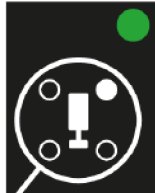
Outriggers controls

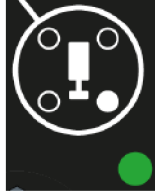
Command		Action
Centralized stabilizer extension/retraction		Press and hold the centralized stabilizer extension/retraction control (4) and simultaneously push the selector (7) down until the machine is stabilized.
		Press and hold the centralized stabilizer extension/retraction control (4) and simultaneously push the selector (7) up until the stabilizers are fully retracted.
Front left stabilizer extension/retraction		Press and hold the stabilizer extension/retraction control (2) and simultaneously push the selector (7) down until the stabilizer is resting on the ground.
		Press and hold the stabilizer extension/retraction control (2) and simultaneously push the selector (7) up until the stabilizer is fully retracted.
Front right stabilizer extension/retraction		Press and hold the stabilizer extension/retraction control (3) and simultaneously push the selector (7) down until the stabilizer is resting on the ground.
		Press and hold the stabilizer extension/retraction control (3) and simultaneously push the selector (7) up until the stabilizer is fully retracted.
Rear left stabilizer extension/retraction		Press and hold the stabilizer extension/retraction control (6) and simultaneously push the selector (7) down until the stabilizer is resting on the ground.
		Press and hold the stabilizer extension/retraction control (6) and simultaneously push the selector (7) up until the stabilizer is fully retracted.
Rear right stabilizer extension/retraction		Press and hold the stabilizer extension/retraction control (5) and simultaneously push the selector (7) down until the stabilizer is resting on the ground.
		Press and hold the stabilizer extension/retraction control (5) and simultaneously push the selector (7) up until the stabilizer is fully retracted.

N.B.-:-THE RELEASE OF THE SELECTORS AND (OR) JOYSTICKS CAUSES ALL MOVEMENT TO STOP.



D - Operation instructions

3.3 Movement control

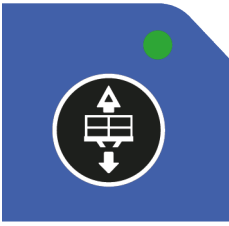

Push the joystick (33) and the Enable Switch (31) to perform the movements.

N.B.:-THE ENABLE SWITCH (31) MUST BE ACTIVATED FIRST BEFORE ANY ACTION ON THE JOYSTICK OR SWITCHES.

Command		Action
Platform raising / lowering		<p>Press the platform raising/lowering control (12). Push the movement joystick (33) backwards to raise the platform.</p> <hr/> <ul style="list-style-type: none"> - Press the platform raising/lowering control (12). Push the movement joystick (33) forwards to lower the platform. - Before lowering the platform, retract the extension or extensions.
Full speed platform raising/lowering		<p>Press the platform raising/lowering control (12). Push and hold the full-speed lifting selector (29). Push the movement joystick (33) backwards to raise the platform.</p> <hr/> <ul style="list-style-type: none"> - Press the platform raising/lowering control (12). Push and hold the full-speed lifting selector (29). Push the movement joystick (33) forwards to lower the platform. - Before lowering the platform, retract the extension or extensions.

N.B.:-BEFORE LOWERING THE PLATFORM, THE EXTENSIONS MUST BE RETRACTED TO ENSURE VISIBILITY AND AVOID POTENTIAL CONTACT WITH SURROUNDING STRUCTURES .

3.4 Additional controls

- Horn: Press the horn control (28) to sound the horn. Releasing the control stops the horn.

3.4.1 Activ' Lighting System

Refer to  B.2.4 -Platform control box.

The system Activ' Lighting System illuminates the controls and the surrounding area of the machine. Users can then safely move the machine.

D - Operation instructions

4 Rescue and emergency procedures

4.1 In case of power loss

In the event of power loss, control system failure or other malfunction, platform lowering functions may be accomplished manually.

In an emergency, if the operator has to exit the platform while it is elevated, the transfer of the operator must respect the following recommendations:

- Exit onto a sturdy and safe structure.
- The occupant(s) must ensure that 2 lanyards are used for security/safety. One must be attached to the designated anchorage point on platform the occupant(s) is in and the other attached to the structure intended to get on.
- Occupant(s) must exit the current platform through the normal access.

N.B.:-DO NOT DETACH THE LANYARD FROM THE CURRENT PLATFORM IF THE TRANSFER TO THE NEW STRUCTURE POSES ANY DANGER OR UNTIL THE TRANSFER IS SAFELY COMPLETED. DO NOT TRY TO GET OFF THE PLATFORM BY GRIPPING THE GUARDRAILS. WAIT FOR HELP TO GET OFF THE PLATFORM SAFELY.



4.2 To rescue operator in platform

- In a situation where an operator located in the platform needs to be rescued (for example in case of illness, injury or trapped against a structure making the control box inaccessible), the rescue personnel at ground level needs to obtain rapid and direct access to operating functions. HAULOTTE® has implemented a control system for safely lowering the operator to the ground in the event of an emergency to enable him to receive the necessary treatment. The system enables the occupants to descend to ground level, even if the emergency stop button on the platform control box is pressed in.
- If the platform becomes jammed on an element or a structure (extension extended), preventing it from being lowered to ground level, the person in the platform must be rescued or evacuated by qualified personnel:



The system allows occupant(s) to be lowered to the ground level, even if an Emergency Stop is engaged or if an overload is detected.

Procedure:

- Turn the ground control box key control (21) to the ground control box  position.
- The platform box controls are now de-energized.
- Check that the Emergency Stop button (9) at ground is not pressed in.
- To lower the platform, hold down the Enable Switch (6)  and simultaneously activate the desired control function (5)  .

D - Operation instructions



4.2.1 Operation of overriding system from ground control box

N.B.:-IF THE SAFETY SYSTEMS DO NOT ALLOW NORMAL MOVEMENT FROM THE GROUND CONTROL BOX, OR IN THE EVENT OF OVERHEATING, USE THE OVERRIDING SYSTEM DESCRIBED BELOW.



Operation of the "overriding system" switch must be an exception and not a normal emergency operation.

Procedure:

- Press and hold the "overriding" system control (11) .
- Press the platform raise / lower control (5)  to raise or  lower the platform.

4.3 No power available

Should the electrical controls or main power fail, it is possible to operate directly on the distributor using a mechanical lever.

4.3.1 Manual emergency lowering procedure

Valve

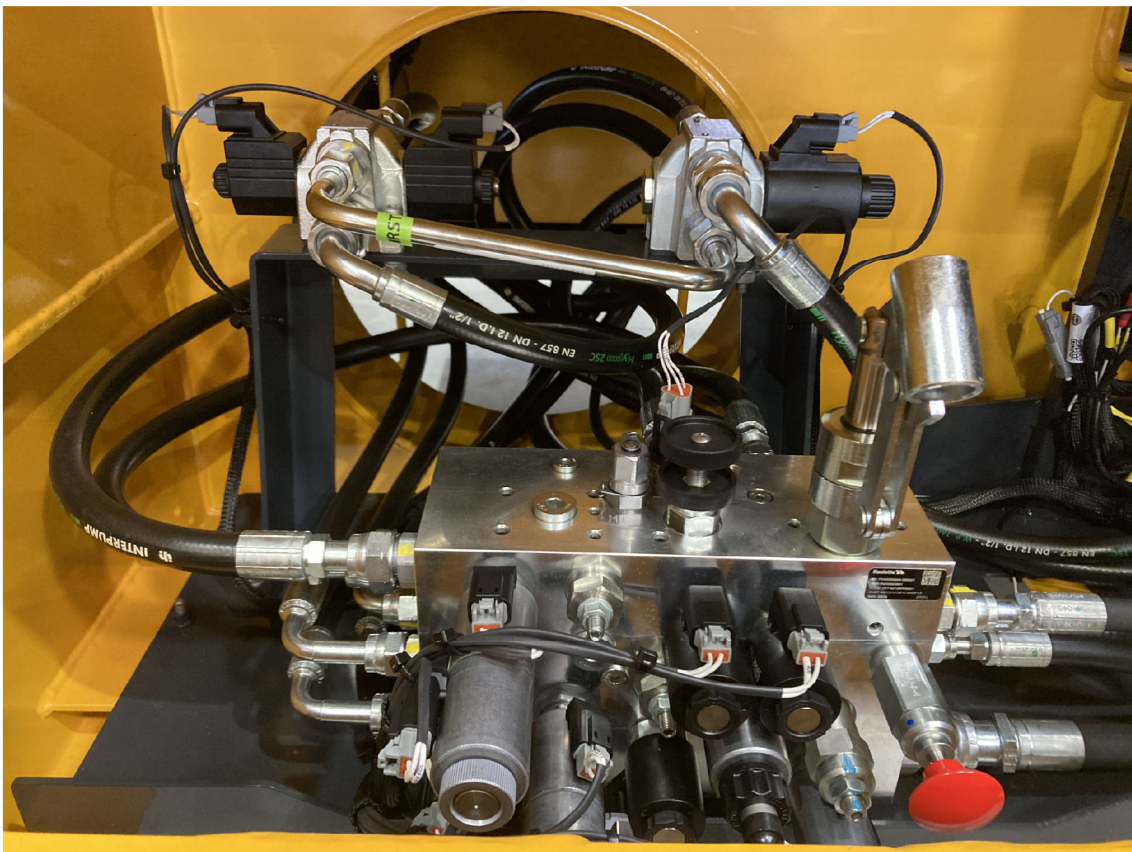

D - Operation instructions

- Actuate the lever (1).
- Pull the handle (2) to open the lower console case .



D - Operation instructions

- Use the lever (3) located in the hood .



- Insert the lever (3) in the return bend of the pump (4).



D - Operation instructions

- Pull the red button and simultaneously push the pump lever until you feel resistance.
- The platform lowering speed is now proportional to the pump operating speed.
- Watch the platform and its surroundings continuously.
- Stop actuating lever (3) and keep button (5) in position until the platform is completely lowered.

N.B.: -IF BUTTON (5) IS RELEASED WHEN THE PLATFORM IS LOWERED, ALL MOVEMENT WILL BE INTERRUPTED AND IT WILL BE NECESSARY TO RESTART THE EMERGENCY LOWERING OPERATION.

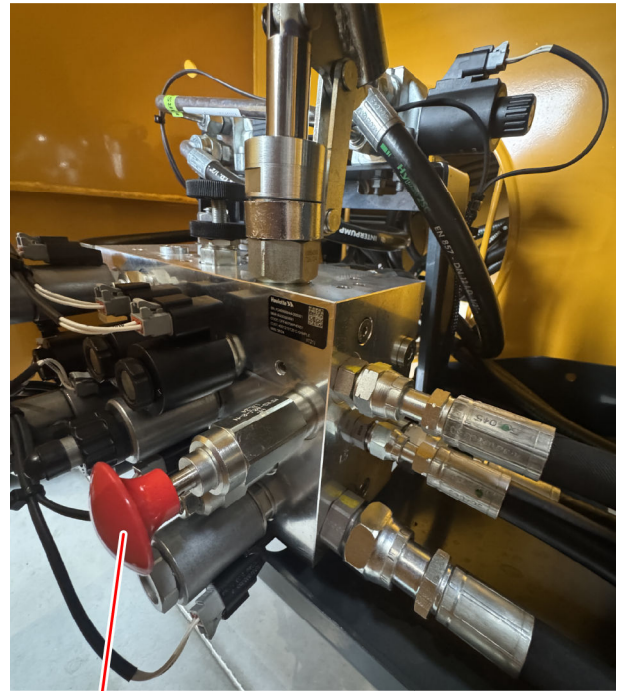

5



Quick and jerky pump operation could lead to rapid lowering, and create a risky situation. Before and during each manoeuvre, ensure that there are no obstacles or people near the platform.

D - Operation instructions

5 Transportation

5.1 Transport configuration



During loading, ensure that:

- The loading ramp can support the machine weight.
- The loading ramp is correctly attached to transport vehicle.
- The loading ramp has sufficient grip surface.
- The transport vehicle must be parked on a level surface and must be secured to prevent rolling away while machine is being loaded or unloaded.
- The floor of the transport truck and/or the trailer can bear the weight of the machine.

To climb the slope, move progressively the drive joystick .

If the slope is too steep, use a winch in addition to traction.

Do not place yourself below or too close to the machine during loading.

The machine must be completely in the stowed configuration:

- Check the platform is completely empty.
- Platform extension must be retracted in the locked position.
- If necessary, fold down the guardrails on flat ground.
- Drive the machine onto the truck bed. While constantly checking the wheel position.



The machine must be loaded onto the truck with a single person on the platform.

- Secure the machine to the tie down points provided (See picture) .



The manual extension (if fitted) must be retracted and locked during transport or towing. The guardrails must be locked and/or folded inwards. Covers closed and properly locked.



Danger: RISK OF CRUSHING FOLLOWING AN UNEXPECTED MOVEMENT

- Ensure that the machine is not on a slope and place a shim in front of the wheels in all cases before releasing the brakes.
- After towing the machine with the brakes released, before uncoupling the towed machine, place the safety shims in front of the wheels and reset the valve to "pushed in" configuration, otherwise the brakes will not be applied.

D - Operation instructions

5.2 Machine stowage for transport

HS21E - HS6395E - HS21E PRO - HS6395E PRO

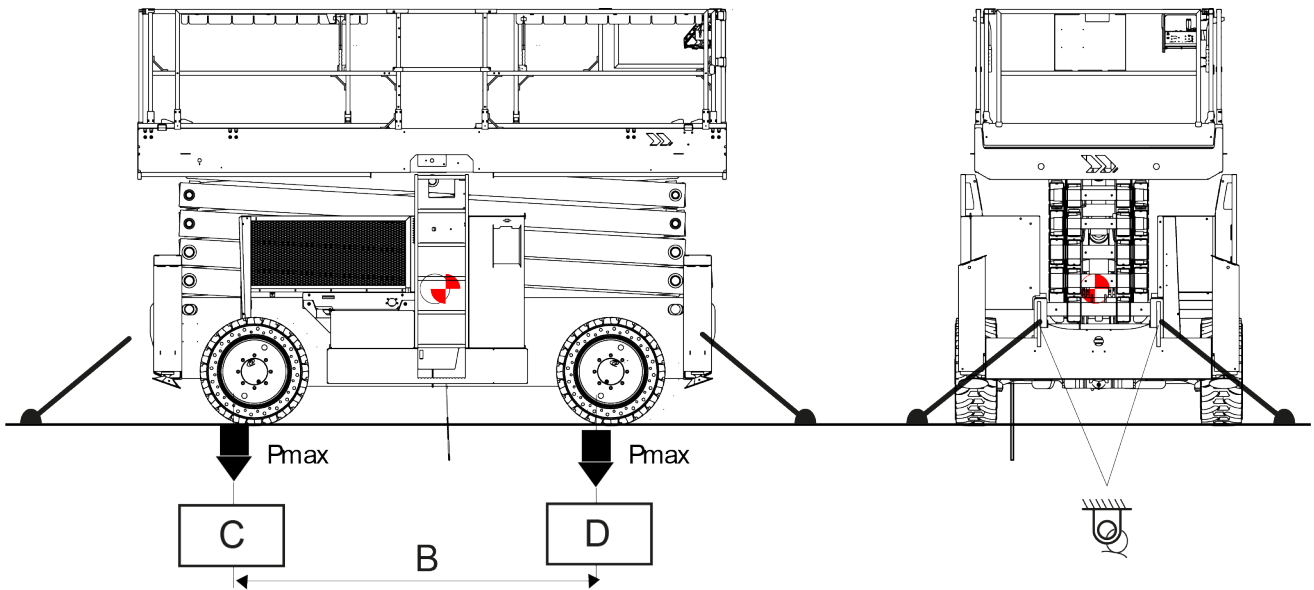

Loading characteristics

Marking	Description	HS21E - HS6395E - HS21E PRO - HS6395E PRO
B	Lateral distance between the wheels	3 m (9 ft 10 in)
C	Front wheel ground pressure	12,9 daN/cm ²
D	Rear wheel ground pressure	12,9 daN/cm ²
	Anchorage point	

5.3 Loading by ramp



To avoid any risk of sliding during loading, ensure that:

- The loading ramp can bear the load.
- The loading ramp is correctly attached.
- The loading ramp has sufficient grip.
- The machine is completely stowed.



To climb the slope, select low driving speed .



- The machine must be loaded onto the truck with a single person on the platform.
- Never place yourself below or too close to the machine during loading.
- A wrong move can lead to the tipping over of the machine and cause serious bodily and material accidents.

D - Operation instructions

5.4 Folding guardrails

5.4.1 Description

Folding guardrails system is designed to allow guardrails to be lowered to reduce the overall height of the machine.

This system facilitates moving the machine through low height doorways/passages.

5.4.2 Safety precautions



- Place the machine on flat ground
- Fully lower the platform to the stowed position.
- Take care to avoid trapping the hands while folding the guardrails.
- User must wear gloves.
- Keep hands clear of pinch points.
- Squat down when moving to avoid falling.



Never fold down or raise the guardrails when the machine is tilted. In these configurations, the extensions are not locked.

5.4.3 Guardrail folding procedure

- Extensions must be retracted and be in locked position for transporting.



Remove the platform control box from its starting position and set it aside in a safe place.

N.B.:-THE PROCEDURE FOR FOLDING DOWN THE GUARDRAILS IS THE SAME WHETHER THE MACHINE HAS THE SUPPORT ACTIV' SHIELD BAR SCISSOR OR NOT.



Whichever guardrail is to be folded down, the operator must always be positioned in the centre of the guardrail before folding it down.



- Remove the lock pins as it folds down.
- Hold the guardrail that is to be folded down by hand to prevent it from falling over abruptly.



- Perform these operations on flat, horizontal ground.

D - Operation instructions

Order of folding for the guardrails, extensions retracted

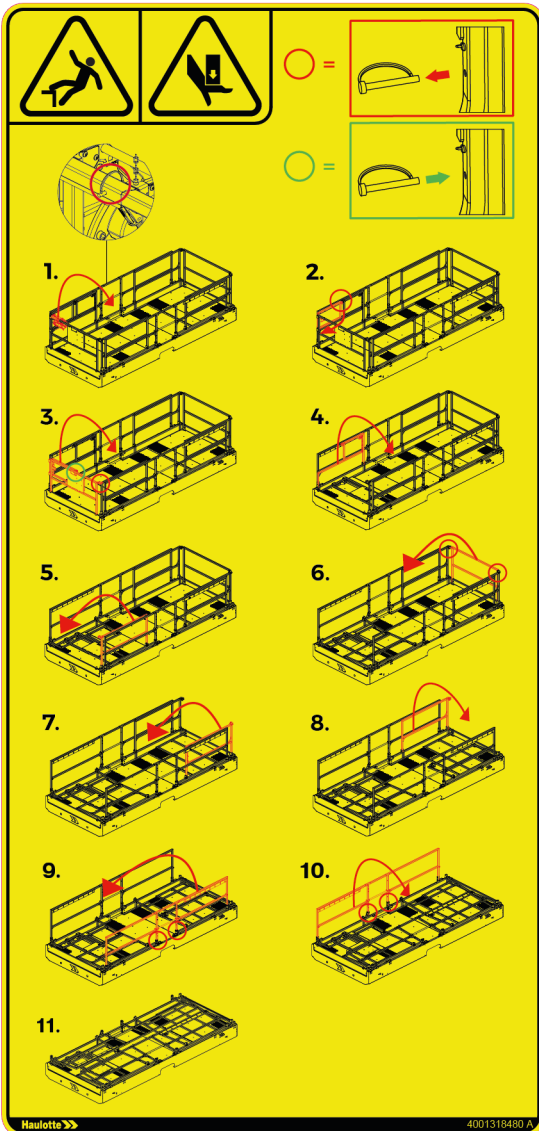

D - Operation instructions

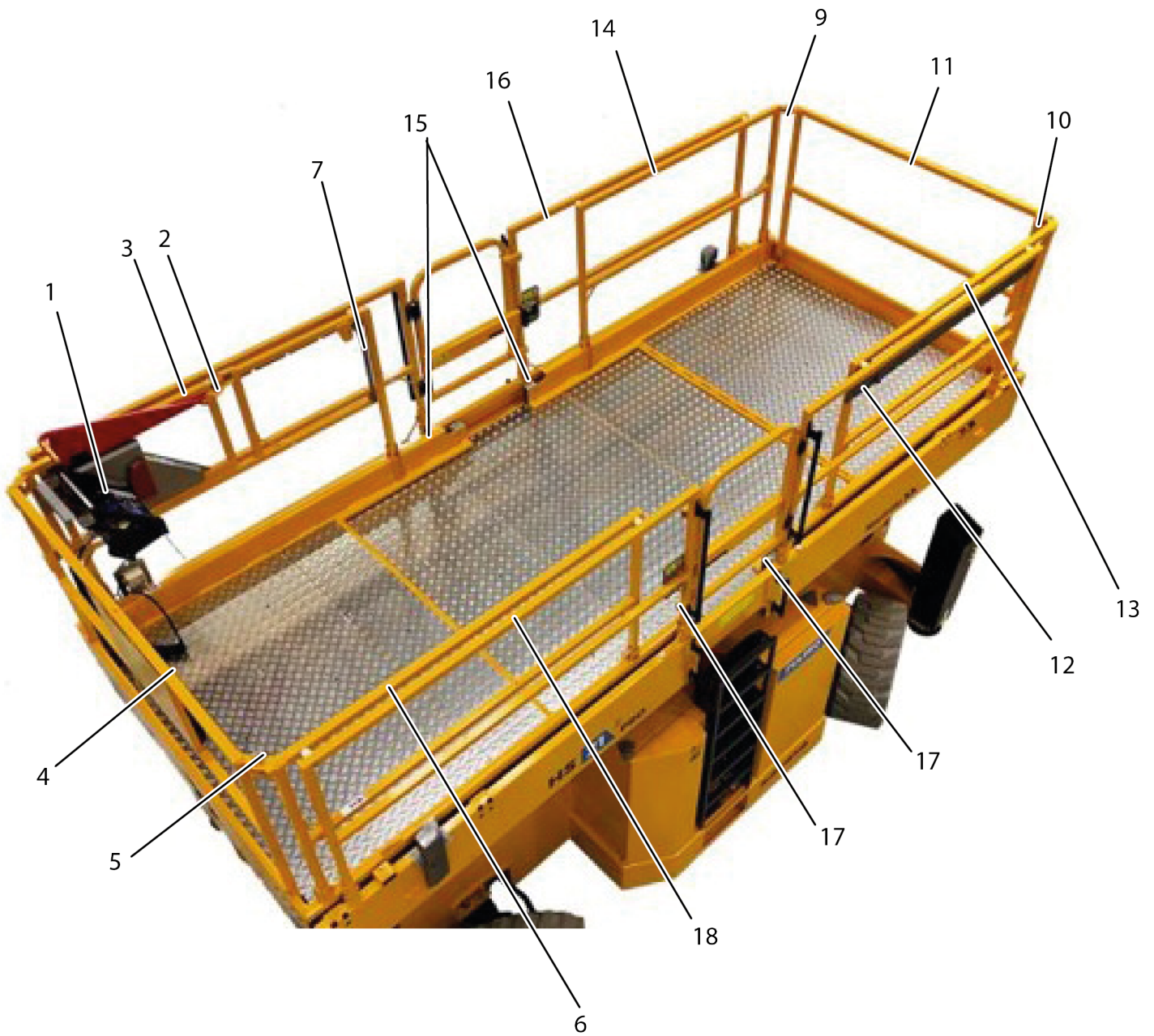

D - Operation instructions

Guard rail front extension

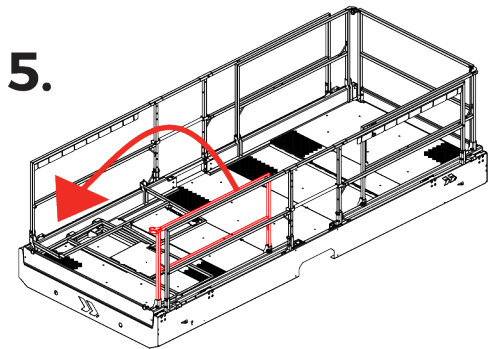
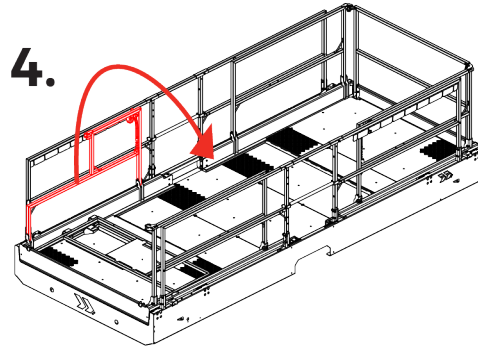
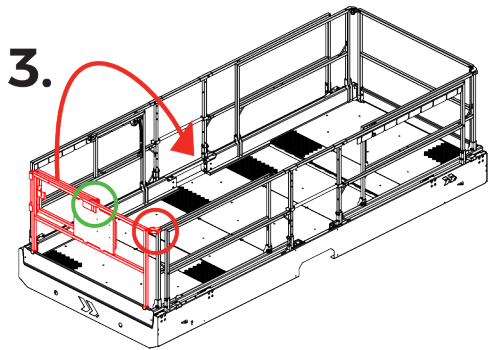
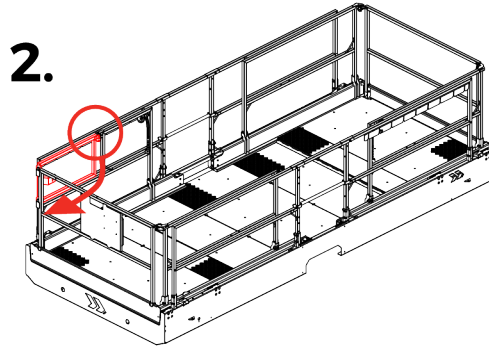
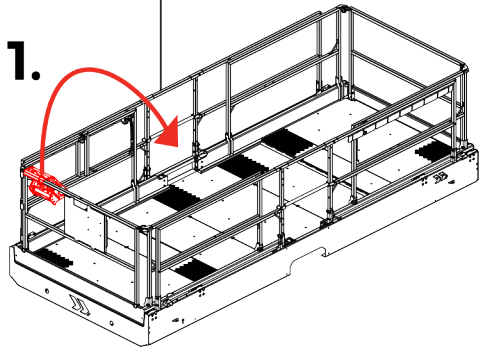
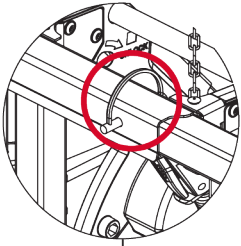

D - Operation instructions

- Remove the platform control box (1) in the centre of the platform.
- Remove the pin (2).
- Fold the support (3) on the front guard rail (4).



- Fit the pin (2) in place.
- Fold the front guardrail (4).



D - Operation instructions

- Remove the pin (5).
- Fold the front guardrail (4).



Guard rail rear extension

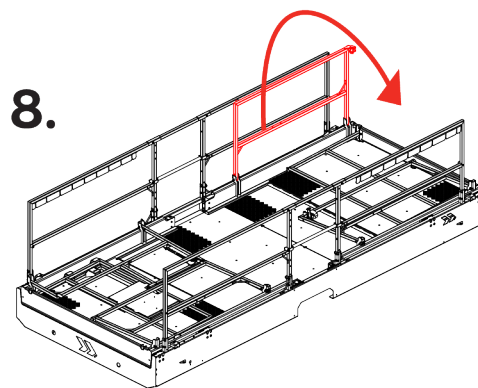
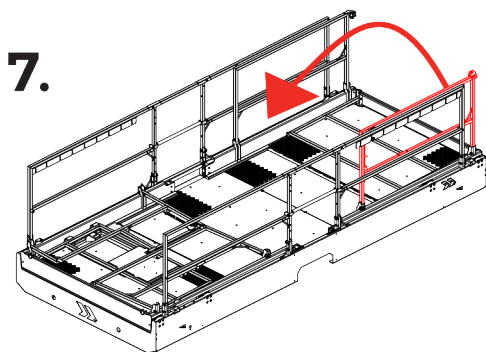
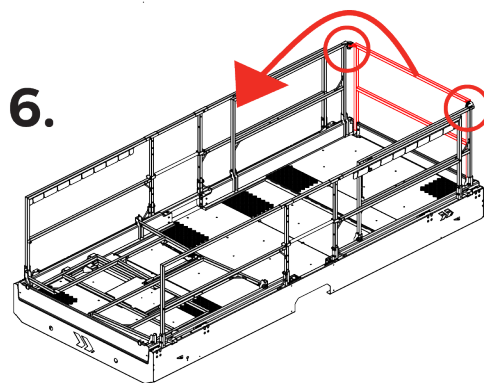

D - Operation instructions

- Remove the pins (9) and (10).
- Fold the rear guardrail (11).

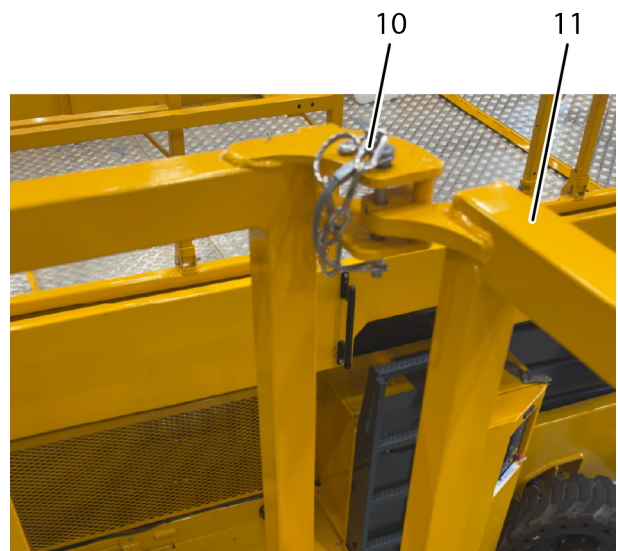
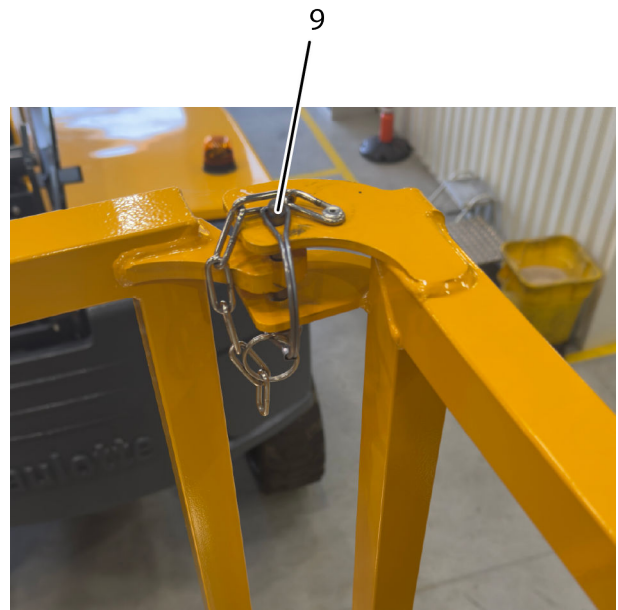

D - Operation instructions

- Lift the handle (12).
- Fold the rear left guard rail (13).

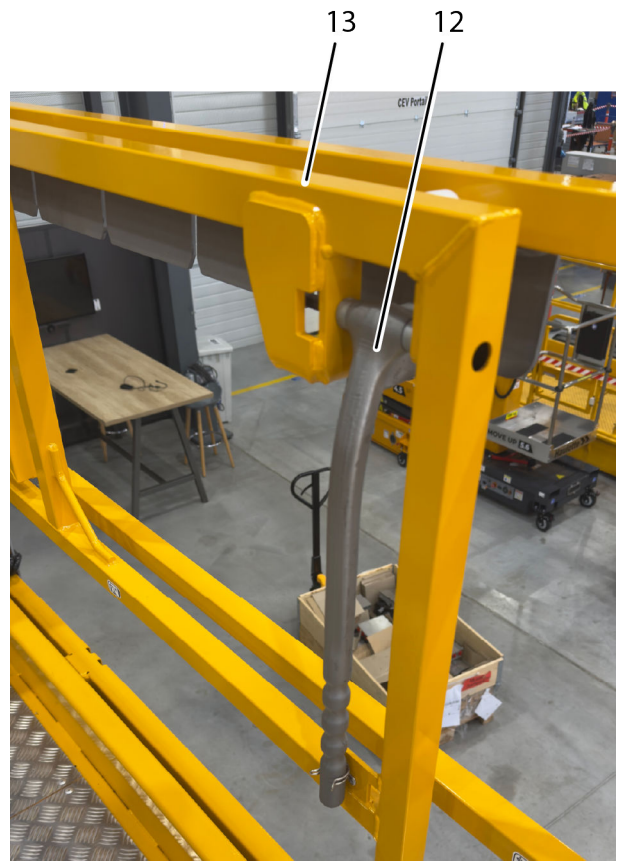

- Fold the rear right guard rail (14).



D - Operation instructions

Left side guard rail

9.

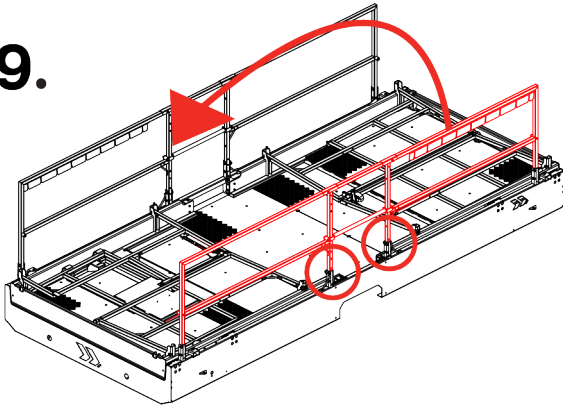

- Hold the guardrail firmly.
- Remove the 2 pins (17).
- Fold the left side guard rail (18).

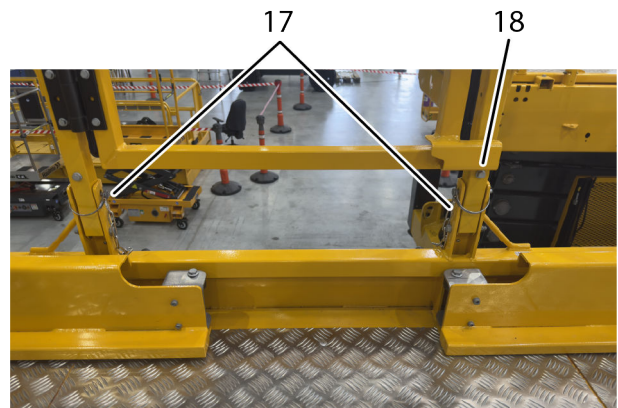

Right side guard rail

10.

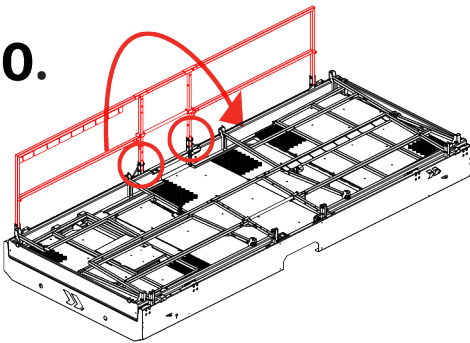

- Hold the guardrail firmly.
- Remove the 2 pins (15).
- Fold the right side guard rail (16).

11.

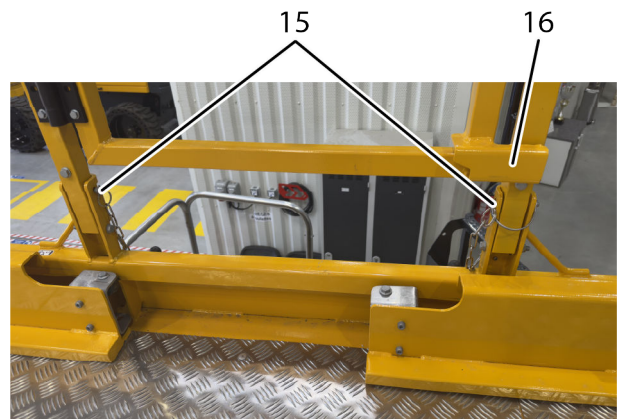
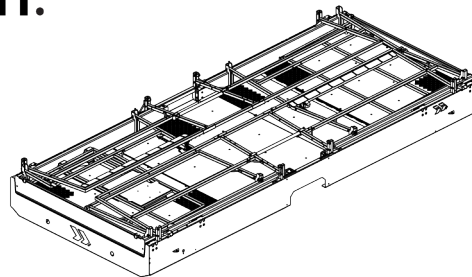

5.4.4 Fitting guardrails in working position

To raise the folded guardrails to the vertical working position:

- Follow the **Folding down the guardrails** sequence in reverse order

D - Operation instructions

- Place the machine on flat ground.
- Ensure all pins are installed and secured.
- Ensure that the extensions are locked



Do not use the machine if the pins are missing, damaged or not approved by HAULOTTE®

D - Operation instructions

5.5 Unloading

Before unloading, check that the machine is in good condition and that it has not suffered any damage during transport.

- Pull the Emergency Stop buttons (9) at ground control box and (1) on the platform control box.
- On the lower control panel, turn the key switch (21) to position  to activate the upper control panel.
- Select low drive speed at the platform control box.
- On the platform control box, press and hold the activation switch (31) while gently and progressively moving the drive joystick (33).

5.5.1 Unloading by ramp



Before operating, check that the machine is in good condition. If the machine has been damaged during transportation, contact the transporter in writing.

1. The machine is completely stowed.
2. Remove the tie downs.
3. Start the machine.
4. The ramps are in good condition and have sufficient capacity and adhesion.





Do not travel down the ramp at a fast speed.

5.6 Towing



In the event of a machine breakdown, the machine can be towed a short distance to load it onto a transport vehicle:

- Lock-out the machine (Refer to the Service Manual  MS0163 - Lock-out procedure) .
- Ensure that no one is in the platform during towing.
- Before towing, ensure that the platform is fully lowered.
- The platform must be empty.
- Ensure that the extensions are locked.
- ALWAYS keep personnel and obstructions clear of the aerial work platform when brakes are released.

To tow a broken-down machine, release brake (Refer to :  D 5.4.1 - Brake release) .



In the towing configuration, the machine is no longer slowed down. Use a drawbar to avoid any risk of accident.



Towing points are identified on the machine using the following labels .



Do not exceed the maximum speed (machine unfolded) (Refer to  B 4.1 - Technical specifications).



To go up or down a slope, use the appropriate winch.



Perform these operations on flat, horizontal ground. Block the wheels to immobilize the machine. The machine is in free wheel mode, so the braking system is not active.

D - Operation instructions

5.6.1 Manual brake release



Perform these operations on flat, horizontal ground. Block the wheels to immobilize the machine. The machine is in free wheel mode, so the braking system is not active.



Use manual control **ONLY** to tow the machine.

The brake release valve is located just above the rear axle, and the tap is in the right-hand compartment:

- Close the tap (3).
- Remove the protective plate covering the brake release valve.
- Press hard on the end of the valve (red part) and simultaneously turn it through a 1/4 turn (clockwise).

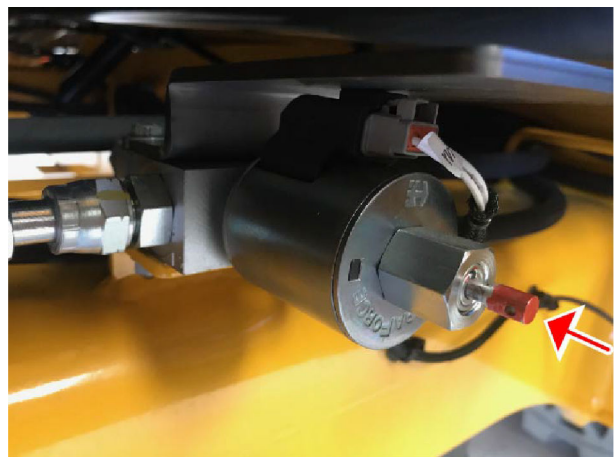
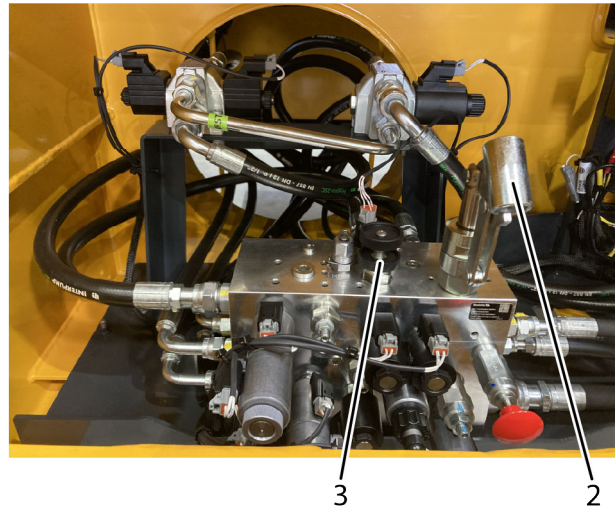

D - Operation instructions

- Open the cover above the ground control box.
- Take the lever to insert in the distributor.



- Insert the lever (1) in the return bend of the pump (2).
- Operate the lever (1) vertically upwards until you feel constant resistance (15 to 20 actions on the lever (1) are usually required).

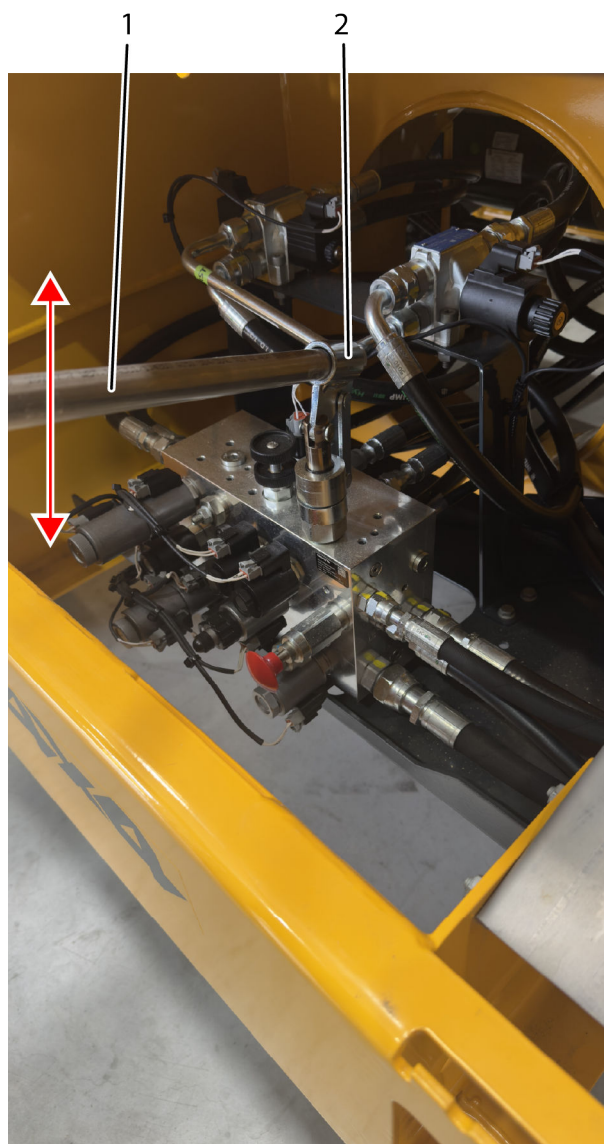

D - Operation instructions

Check that the pressure is higher than 25 bar (362 psi):

- Diagnostic menu (Accessible with level 1 code: 1250).
- Machine status menu (Accessible with level 1 code: 1250).
- Brake release menu (Accessible with level 1 code: 1250).

N.B.:-IF THE PRESSURE DROPS BELOW 22 BAR (319 PSI) DURING TOWING, ACTUATE LEVER (2) AGAIN SO THAT THE PRESSURE RETURNS TO ABOVE 25 BAR (362 PSI).



D - Operation instructions

As soon as the machine is towed to a safe, stable position, the parking brake must be immediately reactivated by unlocking the brake release valve:

- Remove the lever (1) from the return bend of the pump (2).
- Press hard on the end of the valve (red part) and simultaneously turn it through a 1/4 turn (anti-clockwise).
- Refit the housing.
- Reopen the tap (3) as far as the stop.

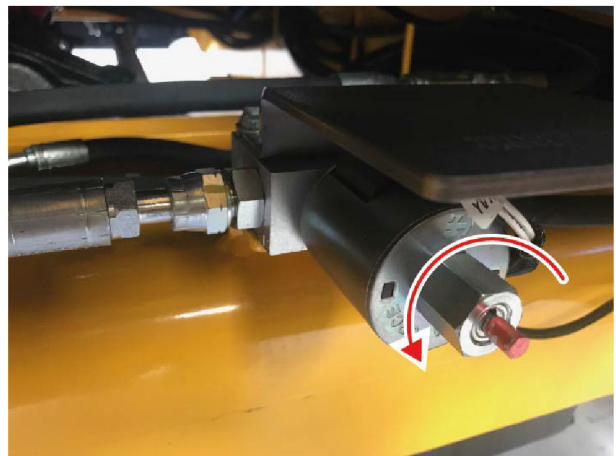
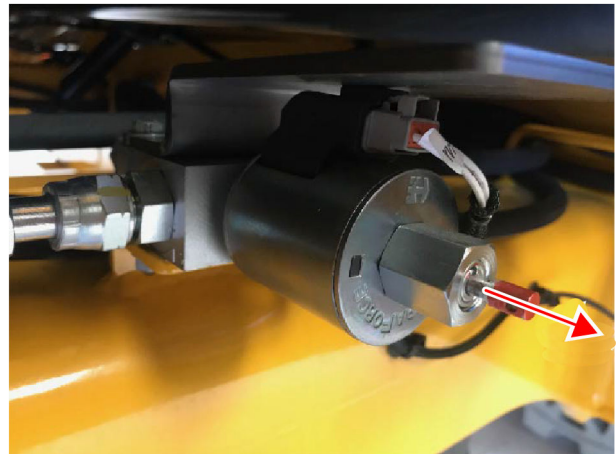

In the towing configuration, the machine is no longer slowed down. Use a drawbar to avoid any risk of accident.



Do not exceed the maximum speed (machine unfolded) (Refer to  B 4.1 - Technical specifications).

5.7 Storage



The machine can be stored in a designated area when not in use. If it is stored for more than 3 months without being used, an inspection must be carried out before it is put back into service.



Keep the batteries charged. Refer to  Section D - Optimise battery life.



Storing the machine with the battery discharged to 0% is prohibited as this will damage the battery.

The batteries self-discharge. The higher the temperature, the quicker the batteries discharge. It is advisable to recharge the battery every month if the machine has been stored and not used.

D - Operation instructions

If the machine is to be stored for more than 72 hours:

- Switch off the ignition and remove the ignition key.
- Emergency Stop button (chassis).

N.B.:-THE BATTERY CHARGER MUST NOT BE CONNECTED TO THE MAINS WHEN BEING LOCKED OUT AND THE FOR ENTIRE LOCK-OUT DURATION.



D - Operation instructions

- Turn the circuit breaker handle.
- Position the lock-out wedge to secure the isolator handle.
- Insert and lock the padlock .

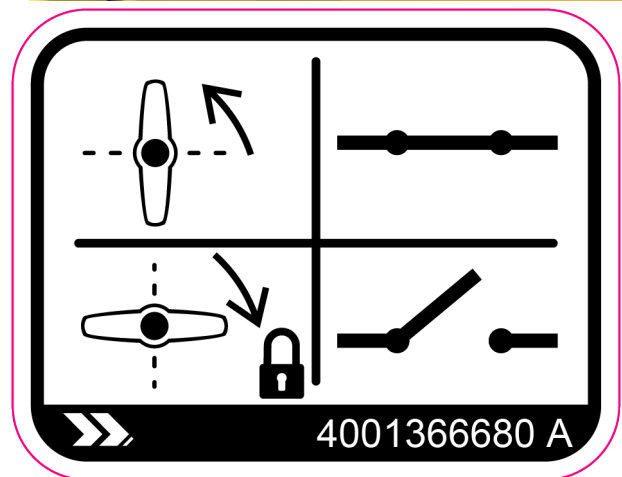

Do not store or immobilise the machine when it is unfolded.

Ensure all access panels, doors and side compartment covers are shut and secured.

- Turn the energizing key selector switch (21) at the ground control box to the "center" position to shut OFF the power.
- Remove the ignition key to prevent unauthorized operation of the machine.



To avoid any risk of corrosion on rods of cylinders during a storage period of more than 1 month:

- In a normal atmospheric environment: perform a complete cycle for the cylinders every 2 months while they are in storage.
- In harsh environments (high levels of salinity in the atmosphere: close to the sea, industrial environment with chloride emissions and/or humidity >70%), we recommend applying the following protection process:
 - Wash and rinse the entire machine with plenty of clean water.
 - Dry all the cylinder rods using an air gun.
 - Apply a solvent-based oil leaving an oily film after evaporation of the solvent directly to all rods left exposed when the machine is in storage position.
 - Re-apply the product every month.



After washing the machine, make sure it is fully air-dry and does not contain moisture on corrosive parts (cylinders rods for example). Do not wash electrical components with a high pressure washer. Wipe away dirt from around electrical components with a dry cloth.

D - Operation instructions

5.8 Lifting operation

During loading / unloading operation with an overhead crane, it is important to respect the following:

- Put the machine in stowed position.
- Platform must be empty.
- Verify that lifting accessories are in good operation and match the technical specifications listed below. It is important that the lifting devices are attached only to the designated lifting eyes.
- Each of the slings used for lifting the machine must be adjusted to keep the machine level and to minimize the risk of damage to the machine.



- Anchorage point for lifting are identified / labeled by the following symbol.
- ONLY trained and authorized personnel should attempt to lift the machine.

5.8.1 Procedure for the use of slings HS21E - HS6395E - HS21E PRO - HS6395E PRO

Machine type	Maximum weight
HS21E (HS6395E)	10 620 kg (23,417 lbs)
HS21E PRO (HS6395E PRO)	10 750 kg (23,704 lbs)



The machine must be fully folded, with platform extensions retracted and locked.

Attach 4 shackles of at least 5000 kg / 11,025 lb with the straps (5 m / 16 ft 5 in - 5000 kg / 11,025 lb) minimum to the 4 chassis rings.

D - Operation instructions



Attach the slings using shackles.



Ensure that the shackles are correctly locked.



Check that the rings do not catch on the ground jacks and the platform.

D - Operation instructions



The machine must be handled very slowly.



Pass the slings inside the guardrails to avoid damaging them.
Slings longitudinally is forbidden.

Marking	Description
A	4 straps 5 m (16 ft 5 in) 5 T and 4 shackles 5 T between machine and crane

D - Operation instructions

6 Cold Weather Recommendations

In an extremely cold environment, the machines must be equipped with a specific hydraulic oil.



In cold weather, do not store the machine with discharged batteries.

Please refer to paragraph  D 6.2 - Li-ion battery.

Please refer to paragraph  D 7.2 - Optimise battery life.

6.1 Hydraulic oil



External environmental conditions can reduce performance of the machine if the hydraulic oil temperature does not reach its optimum range.

It is recommended to use the hydraulic oil according to weather condition. Refer to the table below.

Environmental conditions	SAE Viscosity grade
Ambient temperature between - 15°C (5°F) and + 40°C (+ 104°F)	HV 32
Ambient temperature between - 35°C (- 31°F) and + 35°C (+ 95°F)	HV 32 Arctic

N.B.:-YOU ARE ADVISED TO REPLACE THE LOW TEMPERATURE OIL HV 32 ARCTIC WHEN THE AMBIENT TEMPERATURE REACHES + 15°C (59°F). IT IS NOT ADVISABLE TO MIX OILS OF DIFFERENT BRANDS OR TYPES.

6.2 Li-ion battery

1. Automatic battery heating:

- If the temperature of the battery is lower than 5°C, the battery heating system automatically activates.
 - **During machine use:** To restore full optimum performance after a few minutes of heating:
 - **During charging.** To bring the battery to the right temperature before starting charging.
- If the battery temperature is lower than - 10°C, the machine's performance may be reduced.

2. Automatic battery pre-heating function: (Can be activated/deactivated in the diagnostic menu)

- If the machine remains plugged into the mains power supply, you can activate a function which keeps the battery within the optimal temperature range.
- This makes it possible to start up with the battery already in optimal conditions, even in cold weather.



This function increases electricity consumption. This function can be deactivated in the diagnostic menu if you want to limit consumption.

3. Best practices:

- Leave the machine plugged in if you plan to use it in cold weather. This enables the battery to be maintained in optimal condition.
- Avoid using or charging the machine immediately after a long period of storage in the cold without pre-heating.
- Activate automatic battery pre-heating if you need optimal performance as soon as you start using the machine.

D - Operation instructions

7 Battery care and maintenance (For machines equipped with the lithium-ion battery option)

7.1 Battery recharge

7.1.1 On-board charger

The on-board charger is used to charge the batteries. The maximum current is 16A for 220V - 240V and 110V networks. Battery charging starts as soon as it is connected via the mains supply.

N.B.-:WHEN THE MACHINE IS CHARGING WITH THE CONTROL BOX ACTIVATION KEY SELECTOR SWITCH (21) IN GROUND CONTROL BOX POSITION, LIFTING AND LOWERING MOVEMENTS ARE AUTHORIZED. DRIVE AND STABILIZER MOVEMENTS ARE DENIED.

Description	Characteristics
Battery charger	72 V / 42 A
Electric power supply	85-265 V AC / 50-60 Hz / 16 A
Battery voltage	77 V
Charging time	From 20% to 100%: 6 h 30 with a standard 230 V AC power supply (except option Range Extender)

N.B.-:

- **IN NEGATIVE TEMPERATURES, THE CHARGING TIME MAY BE LONGER.**
- **THE CHARGING TIME ON THE GROUND CONTROL BOX TOUCHSCREEN (22) IS ONLY DISPLAYED IF THE CONTROL BOX ACTIVATION KEY SELECTOR SWITCH (21) IS IN OFF POSITION.**

Locations



D - Operation instructions

Marking	Description
1	On-board charger
2	Box for fast charging
3	Battery charger mains cable





Never replace the charger cable with a different model or length than the one originally supplied without written authorization from HAULOTTE®.

7.1.2 Battery charging



- Do not use an external charger or jump the batteries.
- Ensure that the mains power supply is adapted and equipped with circuit breakers ensuring it is safe:
 - If a "cable reel" type extension is used, the cable must be completely unwound before recharging.
 - The cable cross-section must be at least 2,5 mm² or more, depending on the length of the cable.
 - The socket must be able to deliver a current of 16 A.
 - If power of the supply is not great enough, a limited charge power can be selected from the (22) screen (Accessible with level 1 code: 1250).

Procedure conditions

Step	Action	
1	In the main menu select:	
2	Machine settings 	
3	Machine configuration 	
4	Option setting	
5	Single-phase	Three-phase
	220-240 V AC / 14 A	16 A /Charger
	220-240 V AC / 12 A	14 A /Charger
	220-240 V AC / 10 A	12 A /Charger
	110-120 V AC / 12 A	
	110-120 V AC / 10 A	



- Never charge a battery when the external temperature is below - 20° C.
- ALWAYS charge batteries in open, well-ventilated areas.
- You are advised to fully charge the battery (100%) at least 1 time each month. If this is not done, a reminder will appear on the (22) screen of the ground control box.

Duration of charge cycle

- 6 hours approximately, on 220 - 240 V AC / 16A network.

D - 40 |

4001367990

E 01.26

USA / GB

D - Operation instructions

- 12 hours approximately, on 110 V AC / 16A network.

N.B.:-CHARGING TIME CAN BE UP TO 8 HOURS LONGER IN COLD WEATHER.

The charge cycle stops automatically when charging is complete.

7.2 Optimise battery life

To optimize battery performance and life-time, you are advised to follow the recommendations below:

- Carry out regular battery maintenance as described.
- Do not store the machine discharged (Duration greater than 72 hours) .
- Carry out full charges regularly.



- In normal use, you are strongly advised to fully charge the batteries 1 time each month to maintain optimal performance.



- Storing the machine with the battery discharged to 0% is prohibited as this will damage the battery.

Keep the top of the batteries clean and dry. Incorrect connection or corrosion may cause a significant loss of power and lead to the power connections becoming abnormally hot.

In use

Full charge (Display of Charge finished and complete  on the platform control screen)	When needed or at least once a month
Opportunity charge	When needed
Partial charge	Allowed

Long term storage (More than 1 month)

Optimal state of charge for storage	40 to 70 %.
Optimal temperature during storage	0° C (32° F) to 35° C (95° F)
Full charge	Every 6 months



- In case of extended storage, you are advised to charge to 70% then disconnect the power circuit  D.5.7 -Storage. Charging the battery every 6 months is still recommended.

D - Operation instructions

Power circuit socket



E - General Specifications

1	Machine dimensions.....	3
2	Major component masses.....	5
3	Acoustics and vibrations.....	6
4	Wheel/Tire assembly.....	7
4.1	Technical specifications.....	7
4.2	Inspection and maintenance.....	7

E - General Specifications

1 Machine dimensions

Stowed / Transport position: Configuration that takes the minimum floor space necessary for storage and / or delivery of the machine - **Access position** HS21E - HS6395E - HS21E PRO - HS6395E PRO

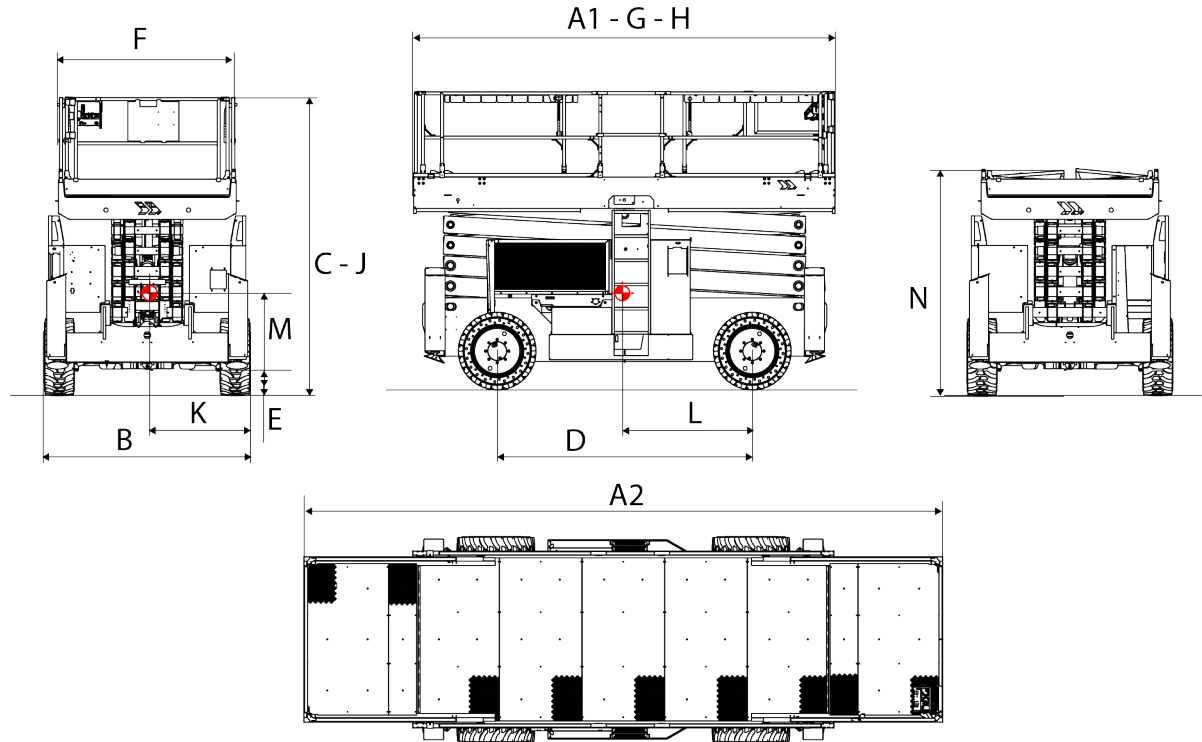

Overall dimension specifications

Machine		HS21E (HS6395E)		HS21E PRO (HS6395E PRO)	
		Standard platform + 2 extensions			
Marking	Specifications-Dimensions	SI	Imp.	SI	Imp.
A1 - H	Overall length of machine (Closed extension) -Storage length	4,96 m	16 ft 3 in	4,96 m	16 ft 3 in
A2	Overall length of machine (Extensions extended)	7,51 m	24 ft 8 in	7,51 m	24 ft 8 in
B	Overall width of machine	2,43 m	8 ft 0 in	2,43 m	8 ft 0 in
C - J	Overall height of machine-Storage height	3,52 m	11 ft 7 in	3,52 m	11 ft 7 in
D	Wheel base	3 m	9 ft 10 in	3 m	9 ft 10 in
E	Ground clearance	31 cm	12 in	31 cm	12 in
F x G	Platform dimensions	2,08 m x 4,96 m	6 ft 10 in x 16 ft 3 in	2,08 m x 4,96 m	6 ft 10 in x 16 ft 3 in
K	Center of gravity- X	1,19 m	3 ft 11 in	1,19 m	3 ft 11 in

E - General Specifications

Machine		HS21E (HS6395E)		HS21E PRO (HS6395E PRO)	
		Standard platform + 2 extensions			
Marking	Specifications-Dimensions	SI	Imp.	SI	Imp.
L	Center of gravity- Y	1,51 m	4 ft 11 in	1,51 m	4 ft 11 in
M	Center of gravity- Z	1,15 m	3 ft 9 in	1,15 m	3 ft 9 in
N	Overall height of the folded guardrails	2,72 m	8 ft 11 in	2,72 m	8 ft 11 in
	Outside turning radius	7,45 m	24 ft 5 in	4,40 m	14 ft 5 in
	Inside turning radius	4,05 m	13 ft 3 in	2,70 m	8 ft 10 in

E - General Specifications

2 Major component masses

N.B.:-MASSES MEASURED WITH EMPTY TANKS.

Specifications	HS21 - HS6395	
	E	E PRO
Frame assembly mass	4930 kg (10870 lbs)	5060 kg (11160 lbs)
Scissors assembly mass	4700 kg (10 360 lbs)	4700 kg (10 360 lbs)
Standard platform assembly mass+2 extensions	1000 kg (2200 lbs)	1000 kg (2200 lbs)
Mass of one wheel	218 kg (480 lbs)	218 kg (480 lbs)
Bare battery mass	220 kg (485 lbs)	220 kg (485 lbs)

E - General Specifications

3 Acoustics and vibrations

The acoustics and vibrations specifications are based upon the following conditions:

- The airborne noise emissions at workstation are determined per European Directive 2006/42/CE.
- The guaranteed sound power level LWA (displayed on the product) is determined per European Directive 2000/14/CE.
- The vibrations transmitted by the machinery to the hand/arm system and to the whole body are determined per European Directive 2006/42/CE.

Specifications	
Sound pressure level at workstation - Platform - Without Range Extender	<70 dBA
Sound pressure level at workstation - Platform - With Range Extender	<70 dBA
Sound pressure level at workstation - On the ground - Without Range Extender	74 dBA
Sound pressure level at workstation - On the ground - With Range Extender	81 dBA
Guaranteed sound power level - Without Range Extender	88 dBA
Guaranteed sound power level - With Range Extender	97 dBA
Vibrations hand/arm	Vibration transmitted by this MEWP to the hand-arm does not exceed 2,5 m/s ² (98,4 in/s ²)
Vibrations whole body	Vibration transmitted by this MEWP to the whole body does not exceed 0,5 m/s ² (19,6 in/s ²)

E - General Specifications

4 Wheel/Tire assembly

4.1 Technical specifications

Component	Standard wheel	Variant wheels
Reference number	910 x 355	
Type	Solid Tyre (Curred - on)	
Wheel mass	218 kg (480 lbs)	218 kg +/- 6 kg (481 lbs +/- 13 lbs)
Size	910 mm x 355 mm (3 ft 0 in x 1 ft 2 in)	
Torque	320 Nm (236 lbs ft)	

4.2 Inspection and maintenance



The tire and rim are bonded together, both must be replaced if either is damaged.

Wheels replacement must be made in the following cases:

- Deformation or cracks on the rim.
- De-bonding between the interface of the steel and the rubber.
- Uniform wear to the wearing line



E - General Specifications

- Non-linear wearing of the tread profile (> 10%)

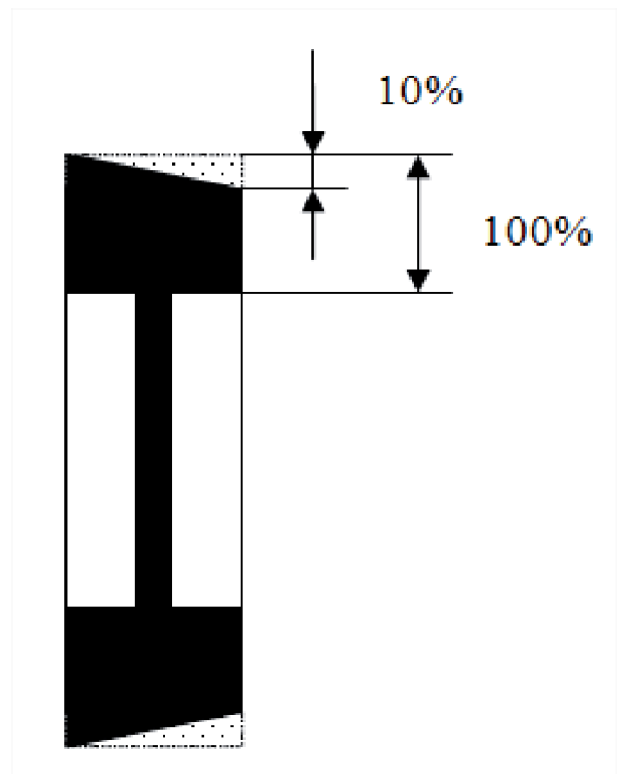

- Linear wear of the tread profile (> 25 %)

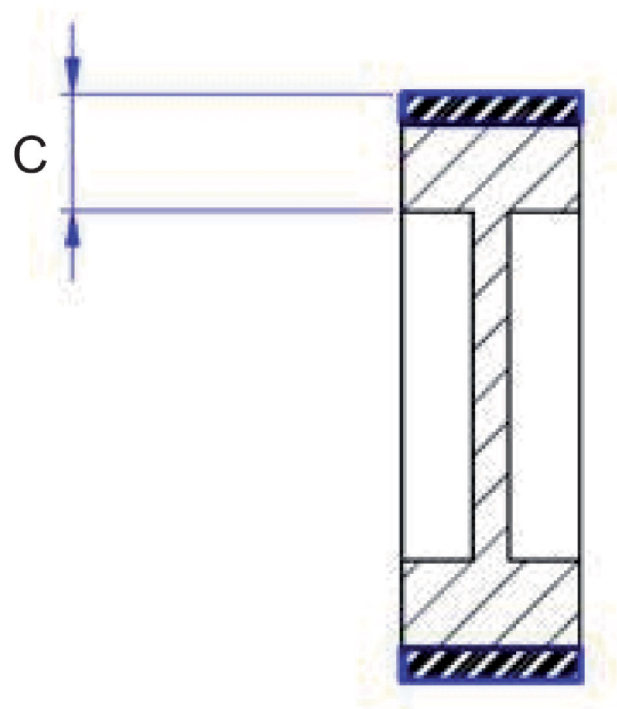

E - General Specifications

- 1 wheel stud is completely torn.
- 2 successive wheel studs are partially torn.
- 2 aperture holes are cut.



Tires and rims are critical components for the stability of the machine. For safety reasons

- Use only HAULOTTE® spare parts according to the technical characteristics of the machine. Refer to the spare parts catalog.
- Do not replace factory-installed tires with tires of different specifications or ply rating.
- Never replace a solid (rigid) tire with a foam-filled or a pneumatic (air-filled) tire.

Procedure of replacement:

- Loosen the wheel nuts on the wheel to be removed.
- Raise the machine using a jack or a hoist with a suitable capacity.
- Rest the machine on the jack stands.
- Remove the wheel nuts.
- Remove the wheel.
- Install the new wheel.
- Tighten the nuts to lock the wheel.
- Lower the machine to the ground.
- Tighten the wheel nuts to the recommended torque. Refer to maintenance and repair manuals.

N.B.-:IF A WHEEL IS REPLACED, LOOK AT THE AXLE TRACK PATTERN (WHICH INDICATES THE FORWARD DIRECTION OF ROTATION) TO CHECK THAT THE INSTALLATION IS CORRECT.

F - Maintenance

1	General.....	3
2	Maintenance Schedule.....	4
3	Inspection program.....	5
3.1	General program.....	5
3.2	Daily inspection.....	5
3.3	Periodic inspection.....	5
3.4	Reinforced inspection.....	6
3.5	Major inspection.....	6
4	Repairs and adjustments.....	7

1 General

As an owner and/or operator of Haulotte equipment, your Safety is of utmost importance to HAULOTTE®, which is why HAULOTTE® places such a high priority on product safety.

INSPECTIONS are not only required by HAULOTTE®, but may also be required by industry standards and/or local regulations.

To ensure your equipment continues to achieve the level of performance set in the factory, it is important to maintain it regularly. We remind you that it is strictly forbidden to make any modifications. Regular and timely inspections will reduce equipment down time as well as prevent possible injury.

N.B.-:DO NOT OPERATE UNLESS YOU ARE FAMILIAR AND TRAINED IN THE PRINCIPLES OF SAFE MACHINE OPERATION.

Overview:

- A walk-around inspection of the machine takes only a few minutes at the beginning and end of each shift
— The best way to prevent issues.

What to Do:

- Use your senses: sight, smell, hearing and touch.

Frequency:

- Check your machine periodically during your entire workday.
- Make sure to do your inspection the same way every time.
- Complete one of these inspections at the start and end of each shift.

N.B.-:IF DAMAGE OR UNAUTHORIZED MODIFICATIONS ARE DISCOVERED, THE MACHINE MUST BE REMOVED FROM SERVICE UNTIL REPAIRS ARE MADE BY A QUALIFIED SERVICE TECHNICIAN.

It is the owner's responsibility to ensure the required maintenance as recommended by Haulotte is completed prior to the operation of the machine.

If regular maintenance is not carried out, this may:

- Void the warranty.
- Cause machine malfunction.
- Reduce machine reliability and shorten its service life.
- Jeopardize operator safety.

HAULOTTE Services® technicians are specially trained to carry out extensive repairs, interventions or adjustments on the safety systems or elements of HAULOTTE® machines. They carry genuine HAULOTTE spare parts and tools as required, and also provide fully documented reports on all work completed.

The inspection and maintenance table, identifies the role and the responsibilities of each party in periodical machine maintenance.  C 3 - Inspection and Functional test.

2 Maintenance Schedule

This section provides the necessary information needed to place the machine in safe operation. In accordance with the regulations that are currently applicable, this machine is designed to have a 10 year life span in normal usage conditions. The life may be extended or reduced dependent on the severity of operating conditions, the machine condition itself and by conducting effective inspections and maintenance in addition to other external factors. There are a number of factors which can affect the design life including but not limited to, severity of operating conditions/routine maintenance which should be carried out in accordance with this manual.

Severity of operating conditions may require a reduction in time between maintenance periods. Machines that have been out of service or have not been in use for more than 3 months must undergo a periodic inspection before the machine is put back into service.

Maintenance must be carried out by a competent company or person familiar with mechanical procedures.

Maintenance operations performed must be recorded in a register / log book of the machine.

F - Maintenance

3 Inspection program

3.1 General program

The machine must be inspected on a regular basis at intervals of no less than once 1 per year. The purpose of the inspection is to detect any defect which could lead to an accident during routine use of the machine. Local standards and regulations may require more frequent inspections.

HAULOTTE® requires Reinforced and Major Inspections to be carried out on the product to extend its service life.

Inspections must be carried out by a competent company or person.

The inspection results must be recorded in the safety register or machine log book controlled and overseen by the company manager. This register or machine log book and the list of competent repair persons must be made available to the government work inspector and HAULOTTE Services®.

When	Person-in-charge	Stakeholder	What
Before sale	Owner (or renter)	Competent technician or qualified technician HAULOTTE Service®	Periodic inspection
Before rent	Owner (or renter)	Competent technician or qualified technician HAULOTTE Service®	Daily inspection
Before use or every change of user	Operator	Operator	Daily inspection
Annually (1 year)	Owner (or renter)	Competent technician or qualified technician HAULOTTE Service®	Periodic inspection
5 years	Owner (or renter)	Competent technician or qualified technician HAULOTTE Service®	Reinforced inspection
10 years	Owner (or renter)	Competent technician or qualified technician HAULOTTE Service®	Major inspection

3.2 Daily inspection

The Daily inspection includes a visual inspection, operational checks and testing of the safety systems. This must be conducted by the operator before using the machine.

This inspection is the responsibility of the user. Refer to  C 3.1 - Daily inspection.

3.3 Periodic inspection

The Periodic inspection is a thorough evaluation of the operation and safety features of the machine.

It must be conducted before the sale / resale of the machine and/or at least once every year.

Local regulations may have specific requirements on frequency, and content of inspections.

The severity of operating conditions may require frequent inspections.

This inspection is the responsibility of the owner, and inspections must be carried out by a competent company or person.

This inspection is in addition to the daily inspection.

This inspection should also be conducted after:

- Extensive dismantling and reassembly of major components.
- Repairs involving the machine's essential components.
- Any accident causing stress to the machine.

3.4 Reinforced inspection

The Reinforced inspection is a thorough evaluation of the machine's structural components, to ensure proper functionality of the machine.

This evaluation must occur at a frequency of 5000 hours or every 5 years.

This inspection is the responsibility of the owner, and it must be conducted by a HAULOTTE Services® technician or by a competent company or person.

This inspection includes:

- Daily inspection
- Periodic inspection

N.B.-:REFER TO THE MAINTENANCE MANUAL FOR DETAILS.

3.5 Major inspection

The Major inspection is a thorough evaluation of the machine's integrity and proper functioning; after a normal service life of 10 years.

This evaluation must take place after 10 years of operation and then repeated every 5 years thereafter.

The severity of operating conditions may require frequent inspections.

This inspection is the responsibility of the owner, and it must be conducted by a HAULOTTE Services® technician or by a competent company or person.

This inspection includes:

- Daily inspection
- Periodic inspection
- Reinforced inspection

N.B.-:REFER TO THE MAINTENANCE MANUAL FOR DETAILS.

4 Repairs and adjustments

Extensive repairs, interventions or adjustments on the safety systems or components must be performed by a HAULOTTE Services® technician. Use original spare parts and components only.

N.B.-HAULOTTE SERVICES® TECHNICIANS ARE TRAINED PROFESSIONALS TO PERFORM EXTENSIVE REPAIRS, INTERVENTIONS AND ADJUSTMENTS ON THE SAFETY SYSTEMS OR COMPONENTS OF HAULOTTE® MACHINES. THE TECHNICIAN CARRIES GENUINE HAULOTTE® SPARE PARTS AND TOOLS AS REQUIRED, AND ALSO PROVIDES FULLY DOCUMENTED REPORTS ON ALL WORK COMPLETED.

HAULOTTE Services® will not take responsibility for any outcomes resulting from inferior services or repairs performed by other unauthorised personnel.

HAULOTTE® reminds that NO modifications SHALL be carried out without the written permission of HAULOTTE®.

Any unauthorised repairs/modifications will void HAULOTTE® warranty.

To check for safety campaigns, consult our website: www.haulotte.com



N.B.-WHEN DISPOSING OR SCRAPPING THIS MACHINE, PLEASE CONSIDER APPROPRIATE METHODS OF RECYCLING. ANY ITEMS THAT REQUIRE SPECIFIC DISPOSAL ARE LISTED WITH INSTRUCTIONS IN THE MAINTENANCE MANUAL.

G - Options

1	Compatibility.....	3
2	Advanced Access Management - Access control and usage restriction.....	4
2.1	Description.....	4
2.2	Additional functions.....	5
2.3	SUPER USER status.....	6
2.4	Code for removing restrictions.....	6
2.5	Operation.....	7
3	Range Extender.....	17
3.1	Description.....	17
3.2	Characteristics.....	17
3.3	Safety precautions.....	22
3.4	Pre-operation inspection.....	22
3.5	Installing / Removing the Range Extender.....	23
3.6	Specific decals.....	28
4	Fast Charge.....	29
4.1	Description.....	29
4.2	Safety precautions.....	29
4.3	Specifications.....	29
4.4	Operation.....	30
5	Plate holder/Tube holder.....	31
5.1	Description.....	31
5.2	Characteristics.....	31
5.3	Safety precautions.....	32
5.4	Pre-operation inspection.....	32
5.5	Disassembly - Assembly	33
5.6	Operation.....	35
5.7	Strapping (Strap not provided)	37
5.8	Storage of the supports on the platform.....	38
5.9	Folding guardrails if machine equipped with plate/tube holder support.....	38
6	Activ'Shield Bar Scissors - Secondary guarding system (if the function is present and the device is installed in its support)	40
6.1	Description.....	40
6.2	Characteristics.....	41
6.3	Safety precautions.....	41
6.4	Pre-operation inspection.....	42
6.5	Operation.....	43
6.6	Specific decals	44
6.7	Insert the console into its support.....	44
7	Central tube holder.....	47
7.1	Description.....	47
7.2	Characteristics.....	47
7.3	Safety precautions.....	48
7.4	Pre-operation inspection.....	49
7.5	Disassembly - Assembly	49
7.6	Strapping (Supplied strap)	52
7.7	Storage.....	53
7.8	Folding guardrails if machine equipped with plate/tube holder support.....	53

1 Compatibility



Before installing any options or accessories, consult HAULOTTE® to check compatibility.

2 Advanced Access Management - Access control and usage restriction

2.1 Description

Access control and usage restriction are options available on a machine equipped with the SHERPAL solution. These options enable the use of the machine to be limited.

These limitations are set and managed from the MyHaulotte platform by the fleet manager.

2.1.1 Access control

The purpose of the access control is to prohibit lifting by an unauthorised operator. Access to the machine is via the RFID code and/or RFID board on the keyboard of the remote RFID reader.

Access control also allows the machine owner to block access to the machine's diagnostic screens for users without the level 3 code (Code available to authorised technicians only) . The level 3 code must be entered on the machine's screen.

2.1.2 Usage restriction

The usage restriction is a machine-related limitation. The usage restriction restricts the use of the machine when it is outside of the conditions of use predefined by the manager.

This function can be set from the MyHaulotte platform by those with the appropriate roles and rights.

The configurable conditions of use are as follows:

- GEOFENCE:-Authorisation for geolocalised use
- TIMEFENCE:-Authorisation for use according to defined time slots
- Remote restriction:-Forced activation of a usage restriction, regardless of the GEOFENCE and TIMEFENCE conditions
- Tracker fault:-Activation of the restriction if tracker in default

When the machine is outside of its conditions of use, only movements allowing micro-speed movement and folding are authorized.

When the machine is subject to a restriction, a message indicates this on the screen of the ground control panel. The user in the basket is notified by the indicator light on the control panel  which flashes at a frequency of 1s ON - 1s OFF.

2.1.3 GEOFENCE

The manager can activate the GEOFENCING restrictions in order to limit the machine's use inside a so-called AUTHORIZED geographical zone or outside a so-called PROHIBITED geographical zone, which he has defined. If the machine leaves this perimeter, its functionality will be restricted..

2.1.4 TIMEFENCE

The manager can activate the TIMEFENCING restrictions in order to restrict the usage during the defined period (Day, Time slot, ...) . If the machine is used outside of the time slot defined by the manager, its functionalities will be restricted.

A GEOFENCING and/or TIMEFENCING restriction becomes active after the machine is folded.

2.1.5 Remote restriction

It is also possible for the fleet manager to set a restriction remotely.

This is equivalent to the forced activation of a restriction, independent of the temporary TIMEFENCING or geolocalized GEOFENCING conditions of use.

2.2 Additional functions

2.2.1 Access control and usage restriction combination

The access control can be combined with the machine's usage restriction. If access control and usage restriction are active, the combination of the two applies so that the user is subject to the constraints of the strongest restriction.

2.2.2 tracker default function

This function allows you to force activation of the restriction in the event of a problem (e.g. tracker removed, unplugged or defective)..

This function is deactivated by default. This function can be activated on the Machine Sheet from the MyHaulotte platform.

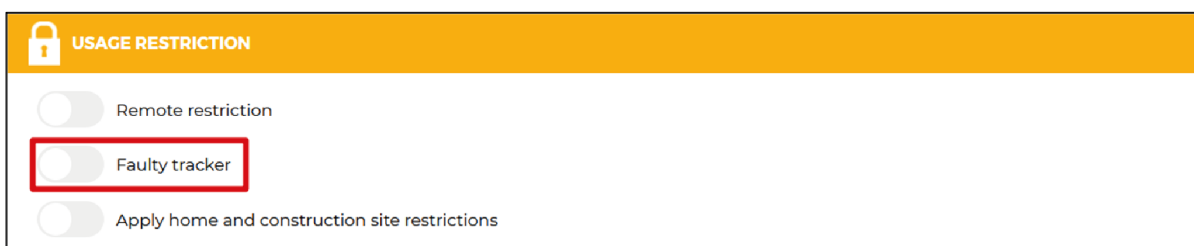
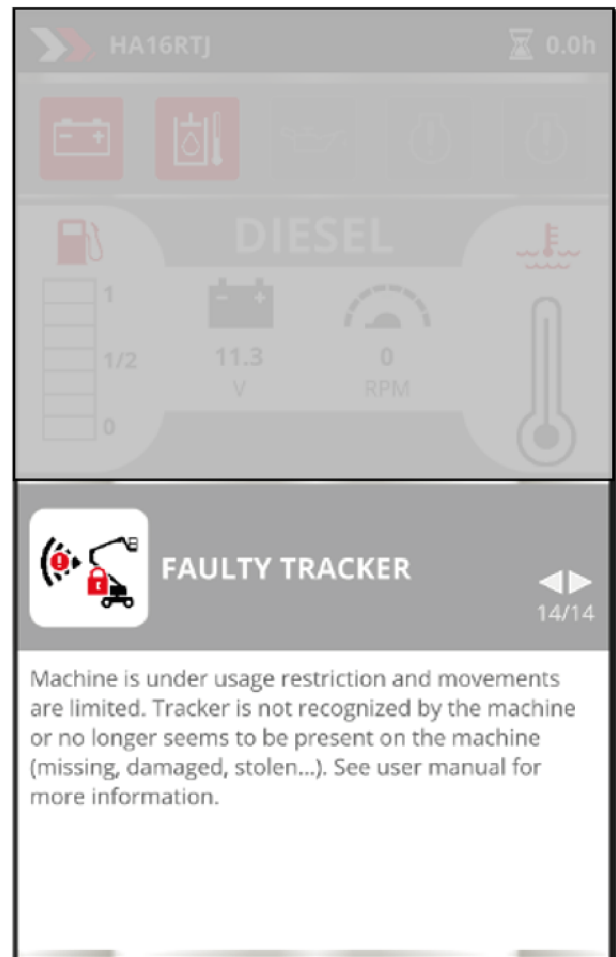

2.3 SUPER USER status

The fleet manager can add Super User status to a user from the MyHaulotte platform. The Super User profile enables the machine to be used, even if it is subject to a usage restriction.

The Super User profile can be connected to one or more machines.

The Super User profile can then start these machines using the PIN code generated by the fleet manager on MyHaulotte or using the RFID card assigned to him.

2.4 Code for removing restrictions

This code enables all restrictions to be permanently removed from a machine (Access control, usage restriction and remote restriction).

The code for removing restrictions is generated by the fleet manager on MyHaulotte. This code must then be entered on the machine's Restrictions Removal Code screen to unlock it permanently.

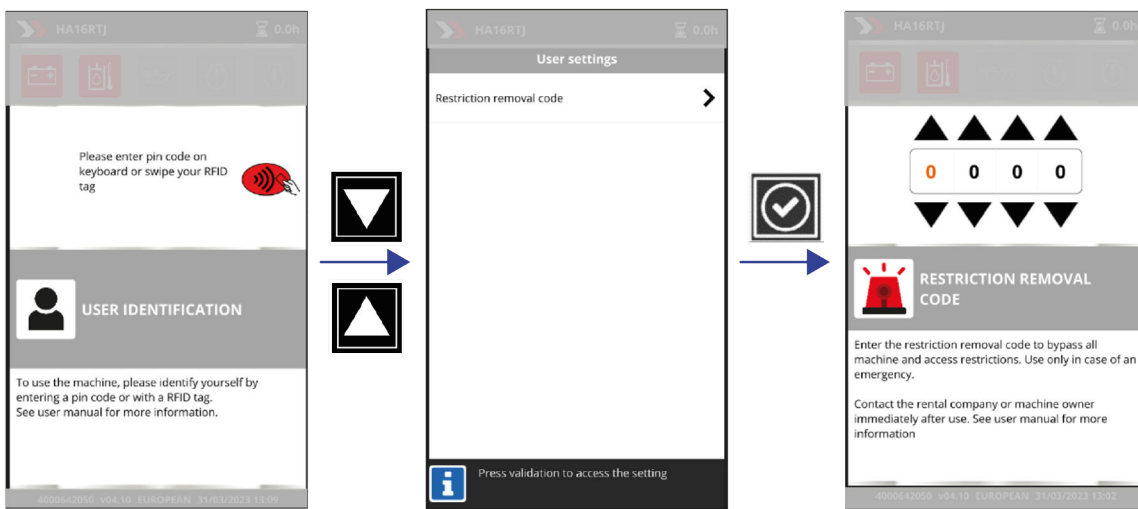

Enter the restriction removal code.



Permanently disable the restrictions and access control.

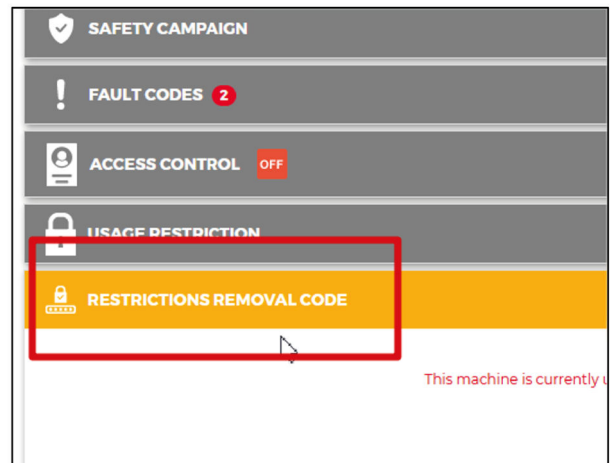

2.5 Operation

2.5.1 Using a machine with access control enabled

The following screen appears when starting up (energizing) the machine.

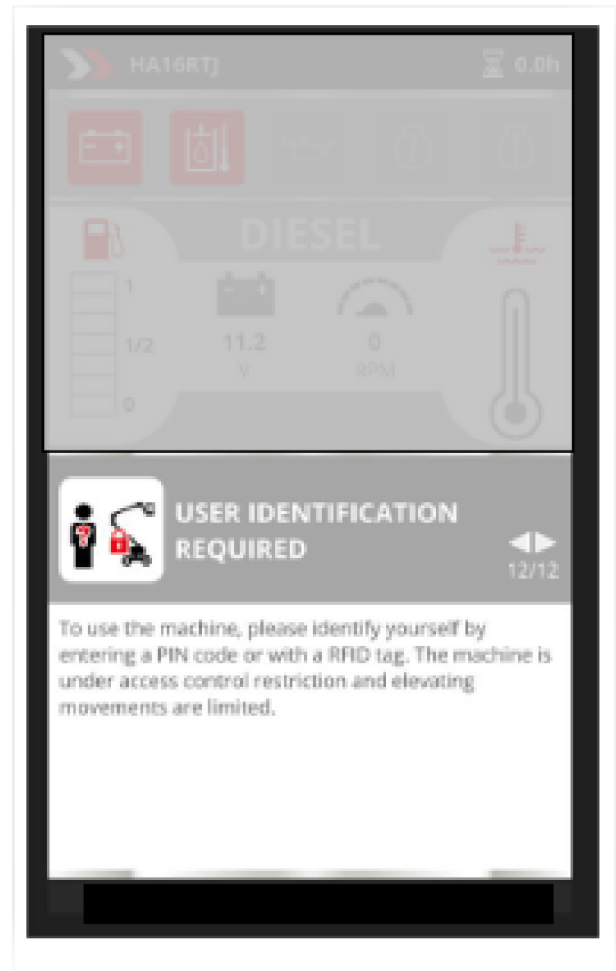

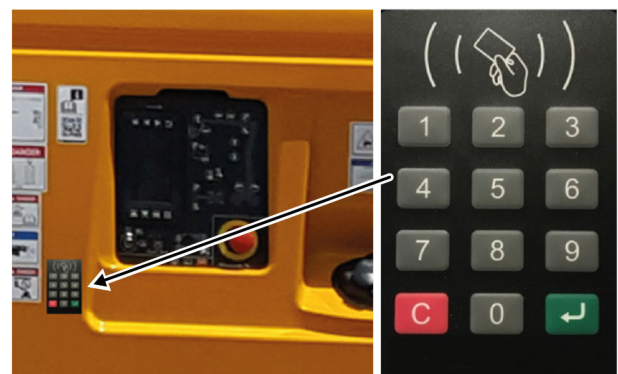

The machine can then be started by:

- A user with a User Identification start-up code. This code must be entered on the remote RFID keyboard.
- A Haulotte® technician with a Haulotte technician Identification. The level 3 code must be entered on the machine's screen.
- A user with a Restrictions Removal Code. This code is owned by the fleet manager or machine owner. The code is generated on the MyHaulotte platform and must be entered on the machine's screen. This code cannot be provided by Haulotte®.



Start-up when access control is enabled:

- Enter the access code or use the RFID swipe card.
- Enter the Super User access code or use the Super User RFID swipe card.
- An authorized technician can use the level 3 code.
- Enter the restriction removal code on the machine's screen.

Marking	Actions
1	On the RFID keyboard, enter the PIN code or use an RFID card or enter the Super User code
	 Permanently disable the restrictions and access control. Return to normal operation.
	Enter the level 3 code  Temporary deactivation (until the machine is switched off) of the restrictions and access control.

2.5.2 Starting a machine with usage restriction enabled

Timefencing restriction activated and use within the time slot authorized

Conventional start-up without access code:

- The following screen indicates that a restriction is in place on the machine.



Timefencing restriction enabled and use outside range is permitted

Start-up when a TIMEFENCING usage restriction is programmed and enabled:

- A message on the screen indicates that a restriction is enabled.
- Enter a Super User access code or use the Super User RFID swipe card.
- An authorized technician can use the level 3 code.
- A user with a code can enter the restriction removal code on the machine's screen.

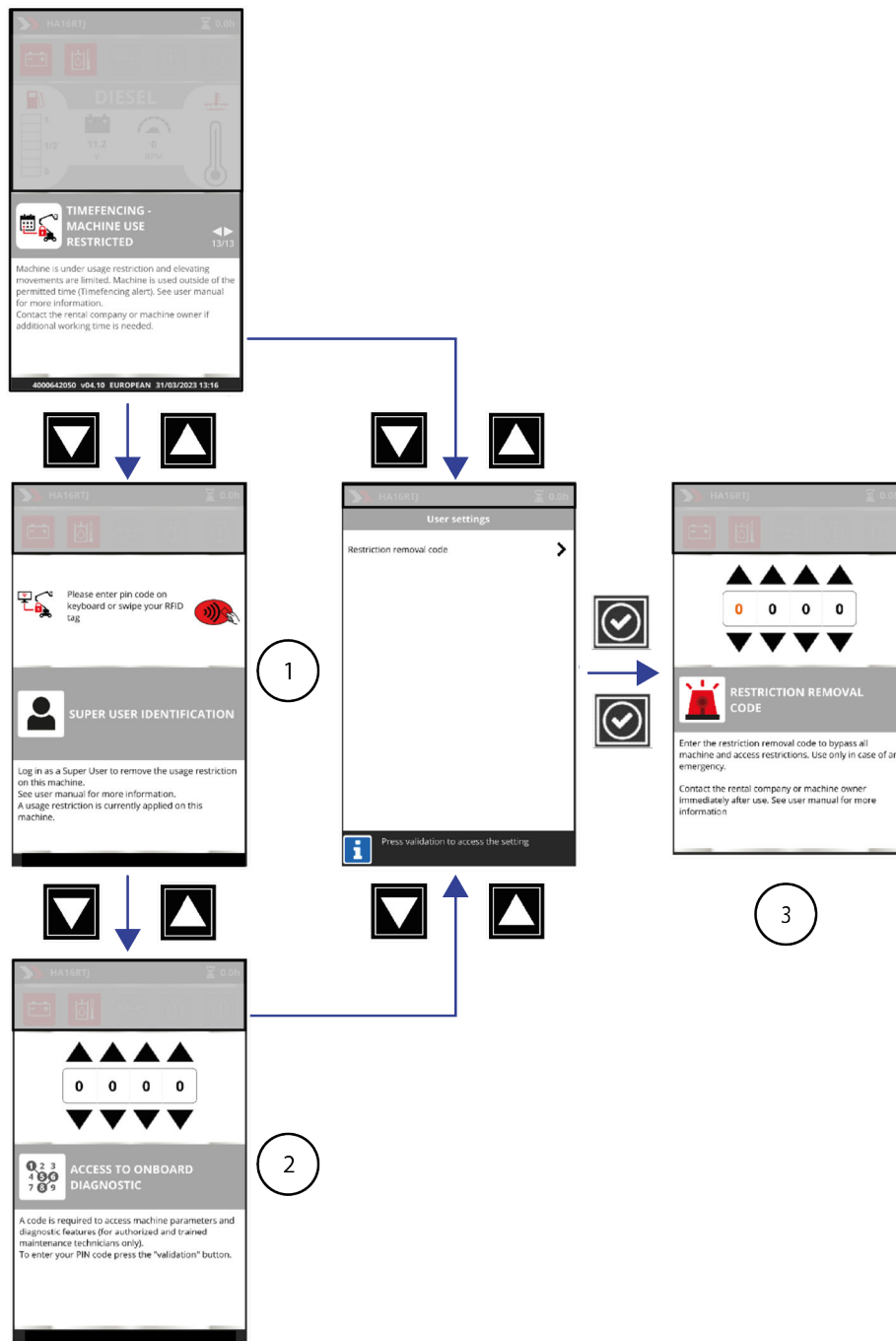
G - Options



Marking	Actions
1	On the RFID keyboard, enter the PIN Super User code or use an RFID card or enter the Super User code
2	Enter the level 3 code  Temporary deactivation of restrictions and access control.
3	Enter the restriction removal code  Permanently disable the restrictions and access control. Return to normal operation.

Geofencing restriction enabled and used in an authorized geographical zone

Conventional start-up without access code:

- The following screen indicates that a restriction is in place on the machine.



Geofencing restriction enabled and used outside of the authorized geographical zone

Start-up when a GEOFENCING usage restriction is programmed and enabled:

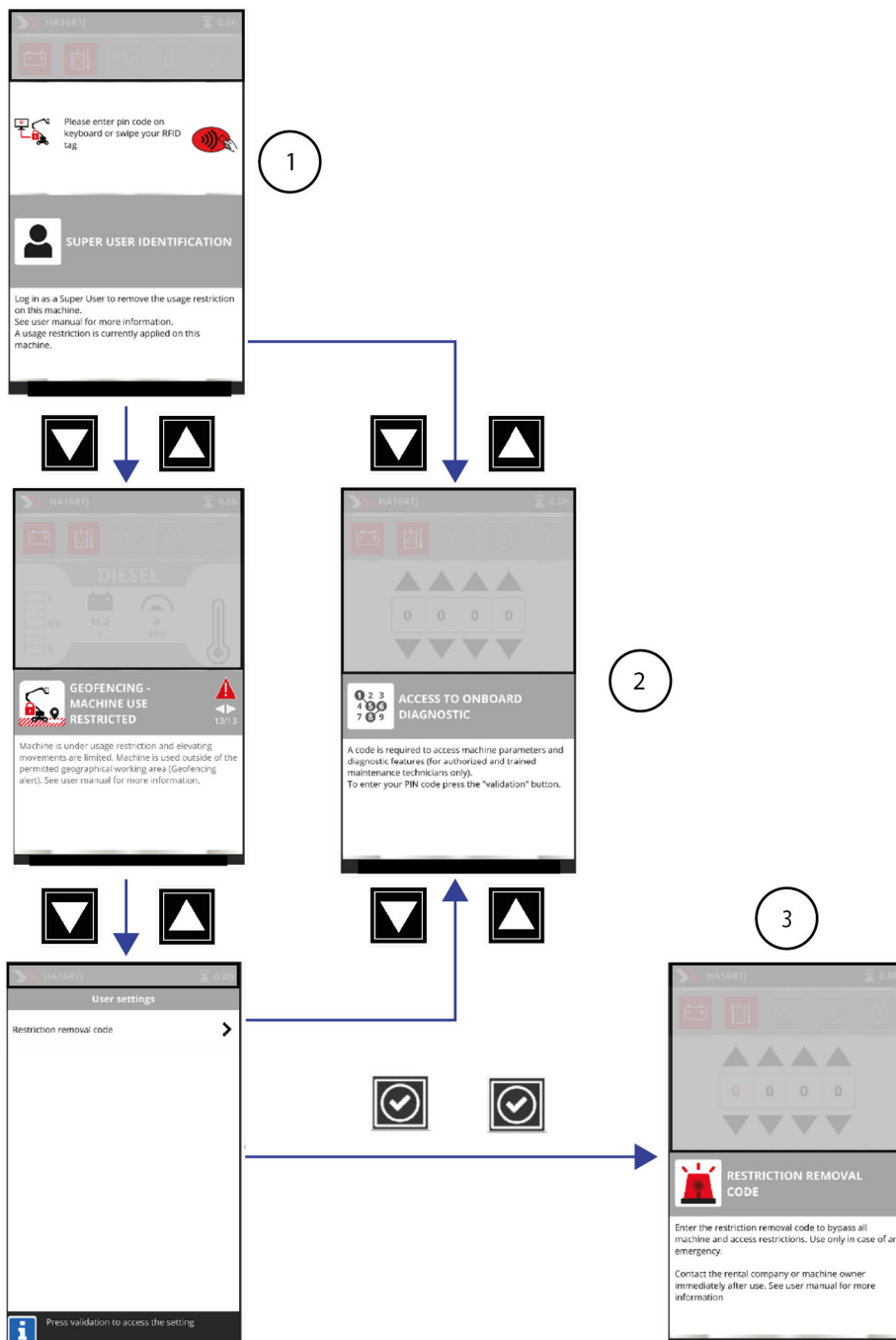
- A message on the screen indicates that a restriction is enabled.
- Enter a Super User access code or use the Super User RFID swipe card.
- An authorized technician can use the level 3 code.
- Enter the restriction removal code on the machine's screen.



G - Options

Marking	Actions
1	On the RFID keyboard, enter the PIN Super User code or use an RFID Super User card or enter the Super User code
2	Enter the level 3 code  Temporary deactivation of restrictions and access control.
3	Enter the restriction removal code  Permanently disable the restrictions and access control. Return to normal operation.



Remote restriction

Start-up when remote restriction is programmed and enabled:

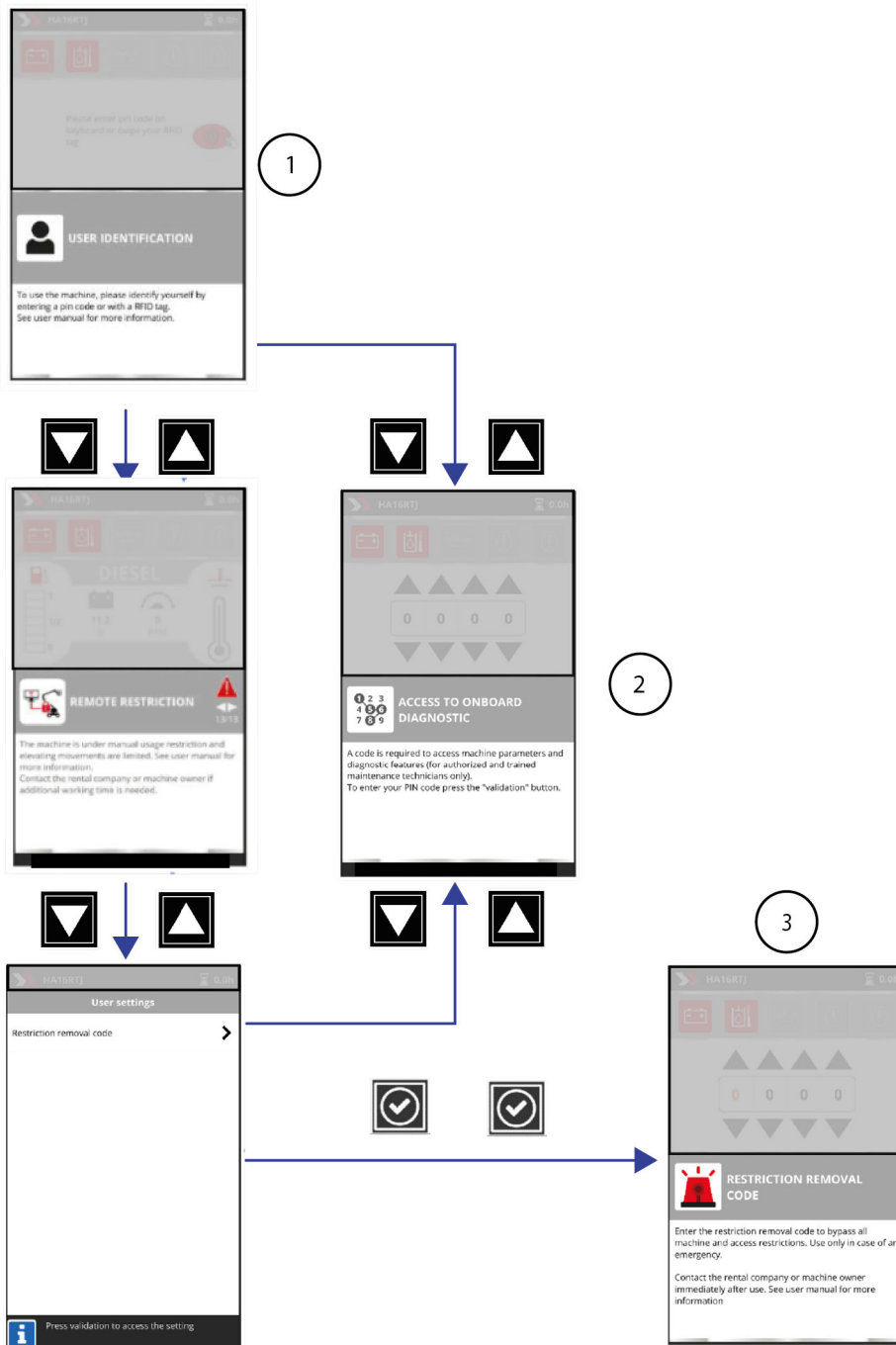
- A message on the screen indicates that a restriction is enabled.
- Enter a Super User access code or use the Super User RFID swipe card.
- An authorized technician can use the level 3 code.
- Enter the restriction removal code on the machine's screen.



G - Options



Marking	Actions
1	On the RFID keyboard, enter the PIN Super User code or use an RFID Super User card or enter the Super User code
2	Enter the level 3 code  Temporary deactivation of restrictions and access control.
3	Enter the restriction removal code  Permanently disable the restrictions and access control. Return to normal operation.

Access control and usage restriction combination

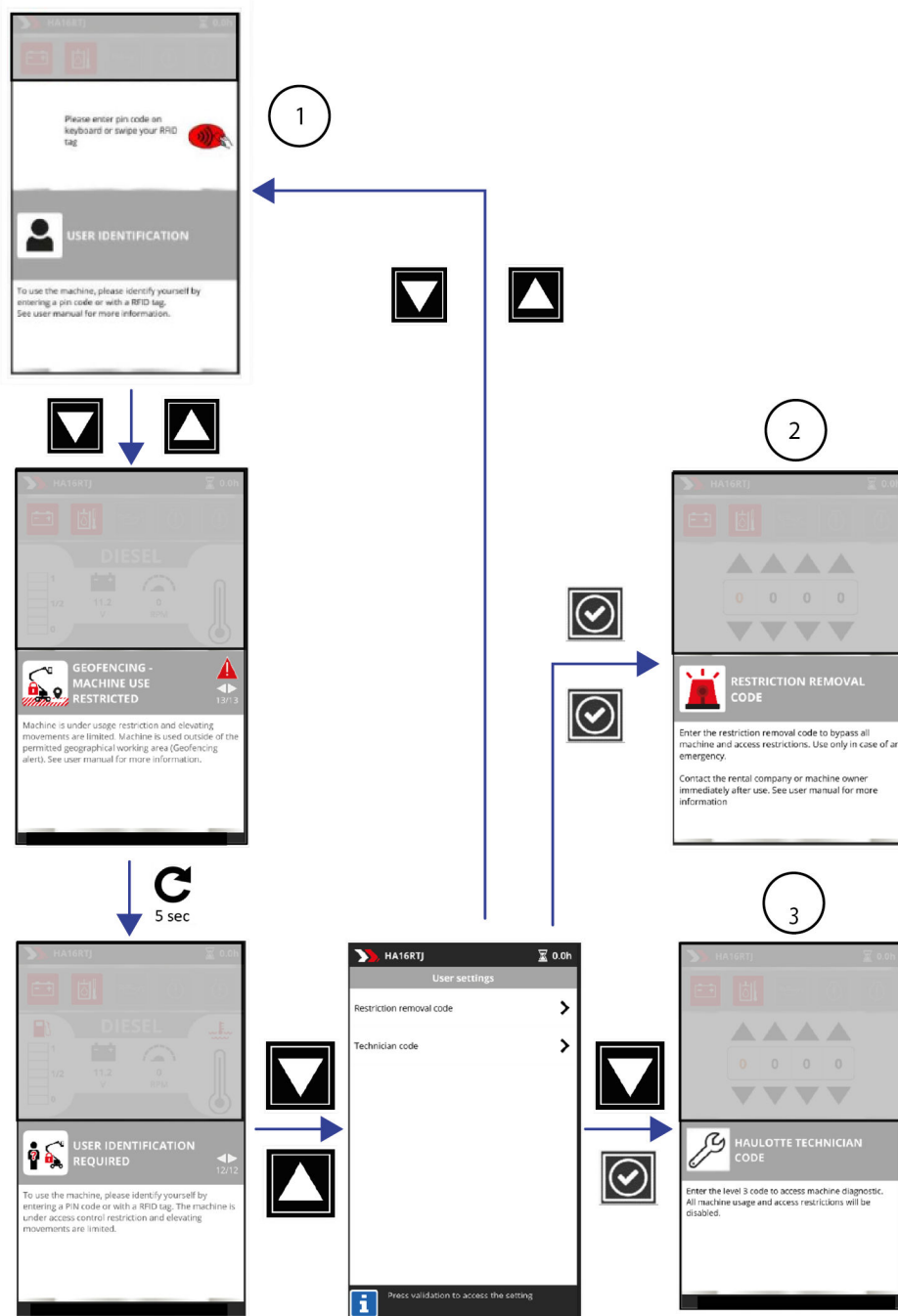
- Enter the machine's access code or use the RFID swipe card (the machine remains under restricted use) or use the RFID Super User swipe card or use the Super User code.
- An authorized technician can use the level 3 code.
- Enter the restriction removal code on the machine's screen.



G - Options

Marking	Actions
1	On the RFID keyboard, enter the PIN code or use an RFID card or enter the Super User code
2	Enter the restriction removal code  Permanently disable the restrictions and access control. Return to normal operation.
3	Enter the level 3 code  Temporary deactivation of restrictions and access control.

3 Range Extender

3.1 Description

This option is designed to charge the machine independently if a power network is not available nearby.

This option is used to power tools in the sockets on the RANGE EXTENDER control panel or to power the platform supply option (if present on the machine).

All lifting and forward movements are possible with a machine equipped with the Range Extender system, as long as the batteries have a sufficient charge level.

N.B.-:THE RANGE EXTENDER CAN ONLY FUNCTION IF THE FAST CHARGE OPTION IS AVAILABLE ON THE MACHINE.

3.2 Characteristics

Range Extender - 1



Marking	Description
1	Engine maintenance hatch

Range Extender - 2

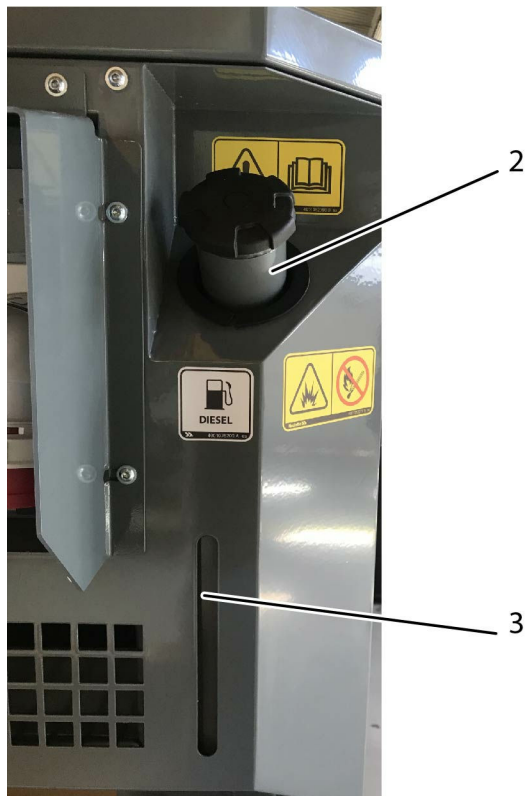

Marking	Description
2	Remplissage carburant
3	Fuel gauge

Range Extender - 3

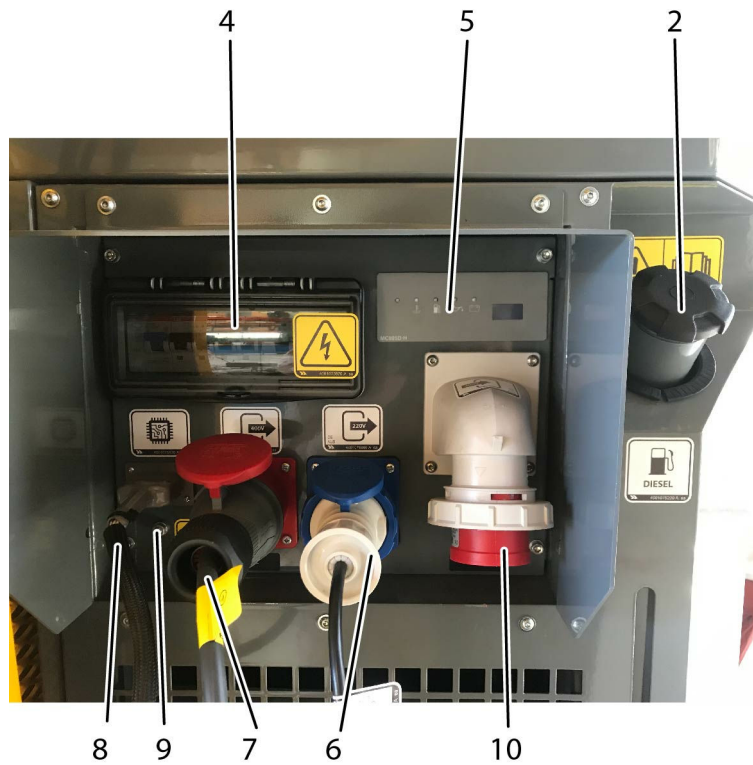

Marking	Description
2	Remplissage carburant
4	Circuit breaker panel
5	Display
6	Platform supply socket
7	Fast charge socket
8	Control socket
9	Earth connection
10	Socket for extension if charged from a 400 V mains

Range Extender - 4

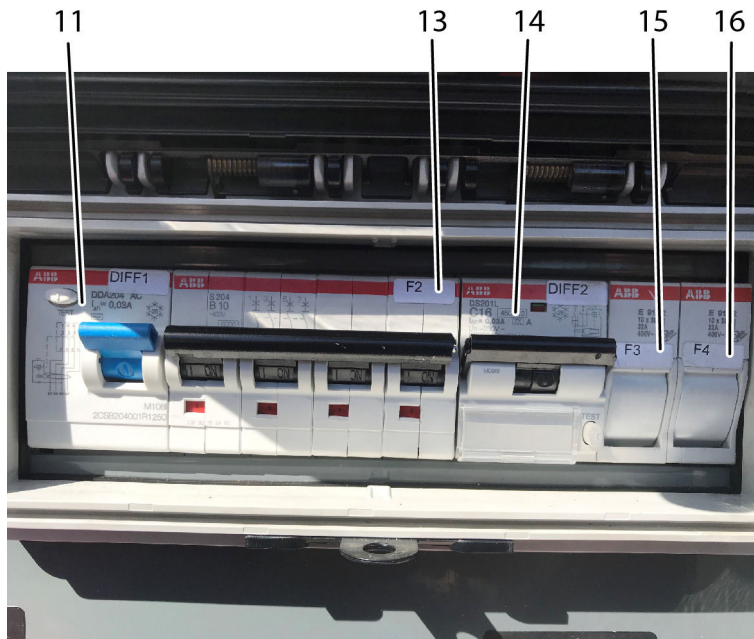

Marking	Description
11	Q3 - Differential circuit breaker
13	Q2 - Three-phase circuit breaker
14	Q1 - Single-phase thermal magnetic and differential circuit breaker
15	F3 - Range Extender + 12V fuse
16	F4 - Range Extender preheating fuse

G - Options

Range Extender - 5



Marking	Description
17	Power supply/Ready to start - Green
18	Engine oil overheat - Red
19	Fuel reserve indicator - Red
20	Low oil pressure - Red
21	Starting battery recharge fault - Red
22	Starter battery voltage, hour meter, current frequency display

	CE, EAC and AS standards	For UKCA only	ANSI and CSA standards
Dimensions (Length / Width/Height)	1250 mm x 622 mm x 812 mm / 4 ft 6 in x 25 in x 32 in	1250 mm x 622 mm x 812 mm / 4 ft 6 in x 25 in x 32 in	1250 mm x 622 mm x 812 mm / 4 ft 6 in x 25 in x 32 in
Weight	254 kg / 560 lb		
Fuel type	Diesel		
Fuel tank capacity	20 l / 5 gal		
Power	4,7 kW		4,9 kW
Noise emission level	102 dBA		
Frequency	50 Hz		60 Hz
Voltage	230 / 400 V	110 / 400 V	110 / 240 V
Amperage	16 A		15 A / 25 A

3.3 Safety precautions



Refer to the manufacturer's manual for more information (supplied with the Range Extender).



- Please read and assimilate the instructions before using the attachment.
- Do not operate the Range Extender in enclosed areas.
- The Range Extender must only be operated on the machine.
- During storage, protect the Range Extender in a safe and stable place.
- In wet weather, protect the Range Extender in a safe and stable place.
- There is a risk of burns if contact is made with the Range Extender, whether in operation or switched off, due to contact with hot parts.
- Do not fill the fuel tank or carry out maintenance operations when the engine is running.
- Do not smoke when working around the battery or when refueling.
- Do not touch hot components. By touching a functioning engine, there is a risk of burns from contact with hot parts, and injuries by the rotating parts. Do not allow children to approach the machine while the engine is running.
- Be sure to conduct daily checks, periodic maintenance, refueling or cleaning on a level surface with the engine shut off and remove the key.
- Whilst the machine is not in use, care must be taken to ensure that if the machine is not locked in a secure location, that the unit key switch is removed to prevent unauthorised use of the machine.
- Reinstall safeguards and shields securely and clear all maintenance tools when starting the engine after maintenance.
- Do not work in an explosive or flammable atmosphere (spark, flame, etc.).
- Do not use water to extinguish a fire. Use the specific systems in place (Powder extinguishers etc.).
- The technician should ensure that suitable PPE (personal protective equipment) for the job is used, and check the particular conditions of environment in which the material can be found (see safety information specific to the operation site). Avoid direct bodily contact with fuel, engine oil and battery acid. In the event of contact with the skin, wash with water and soap, and rinse thoroughly. Do not use organic solvents. In the event of inhalation or ingestion, seek medical attention.

3.4 Pre-operation inspection

- Ensure that the Range Extender is correctly affixed to the machine.
- Check engine fuel level.
- Check that there are no objects obstructing the Range Extender air vents and preventing air from passing through.

3.5 Installing / Removing the Range Extender

- Position the machine on a flat and firm surface, clear of obstructions (beware of power lines).
- Stow the machine.
- Mark out the work area.
- Switch off the ignition and remove the ignition key.
- Place a do not operate tag at the start/stop switch location to inform personnel that the equipment is being worked on.
- Using a hand truck with forks, bring the Range extender to its support and fit it.



Do not slide the Range extender into its support but set it in.



- Tighten the 3 fastening screws to a torque of 76 Nm.



Do not tighten the screws, which can cause the Range extender to tip over.



Fast charge connection

Connect in the order indicated:

- (8) - Control socket ;
- (7) - Fast charge socket ;
- (6) - Platform supply socket (If this option is available) .

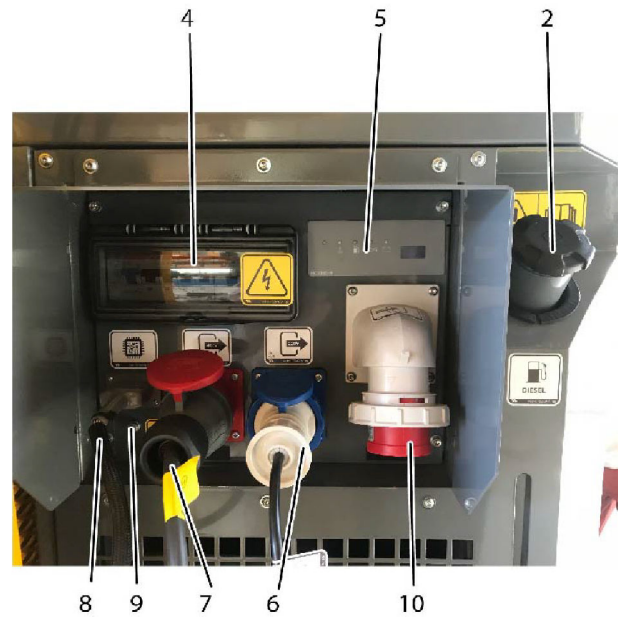

Fast charge connection - From the mains:

- With the Range Extender off, connect the 400 V extension to the socket (10) to enable charging from the mains.

N.B.-:ONLY RAISING IS POSSIBLE IN THIS CASE.

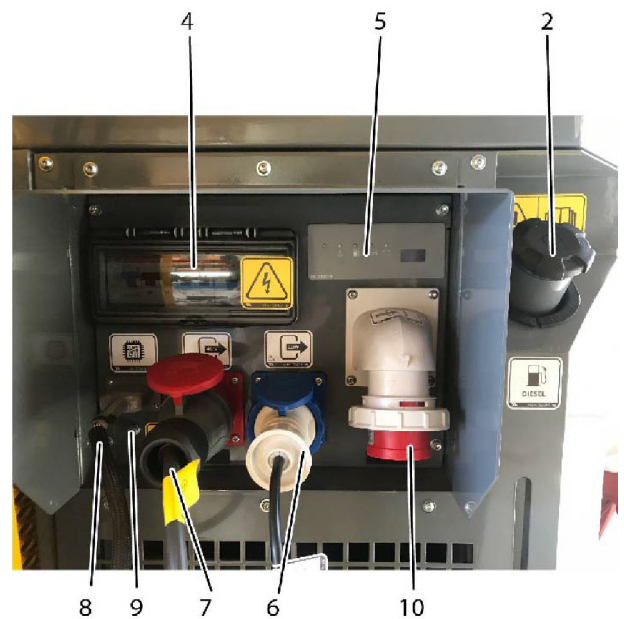

Anti-theft system:

- A padlock can be installed to prevent the Range Extender from being stolen. Not supplied with the machine.

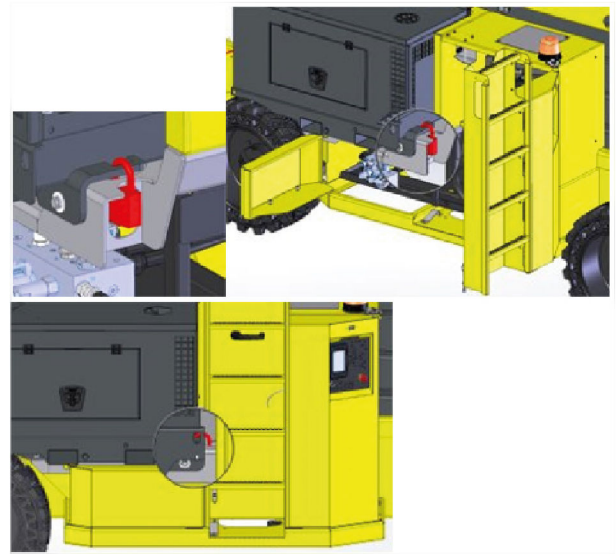

N.B.--STOW THE SOCKETS (3) IN THEIR HOUSINGS.



G - Options

- Using a hand truck with forks, bring the Range extender to its support and fit it.



Do not slide the Range extender into its support but set it in.



- Tighten the 3 fastening screws to a torque of 76 Nm.



Do not tighten the screws, which can cause the Range extender to tip over.



Fast charge connection

Connect in the order indicated:

- (8) - Control socket ;
- (7) - Fast charge socket ;
- (6) - Platform supply socket (If this option is available) .

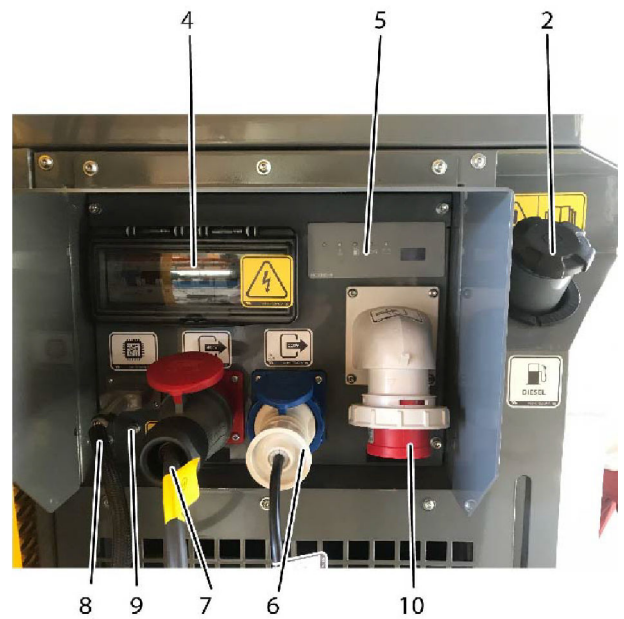

Fast charge connection - From the mains:

- With the Range Extender off, connect the 400 V extension to the socket (10) to enable charging from the mains.

N.B.-:ONLY RAISING IS POSSIBLE IN THIS CASE.

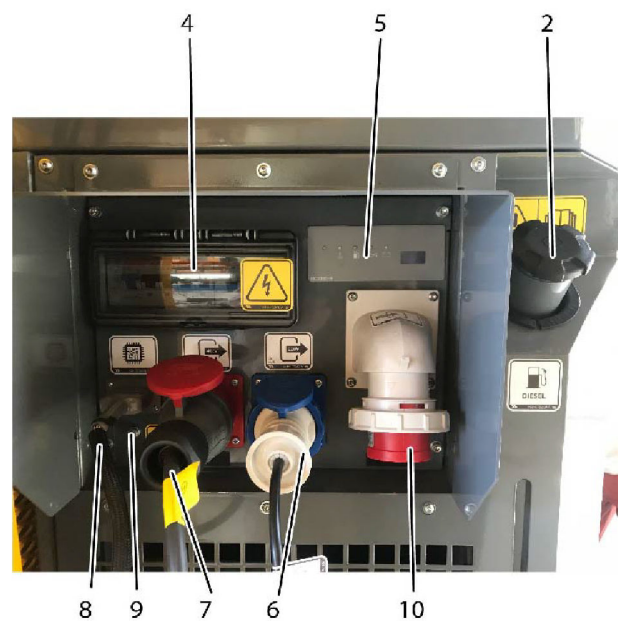

Anti-theft system:

- A padlock can be installed to prevent the Range Extender from being stolen. Not supplied with the machine.

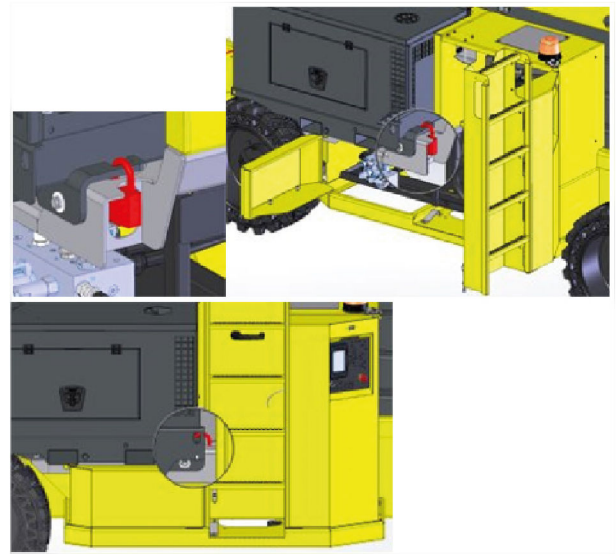
**Removal:**

- Switch off the ignition and remove the ignition key.
- Carry out the operations in the reverse order.

N.B.: -AFTER REMOVAL: STOW THE SOCKETS (3) IN THEIR HOUSINGS.

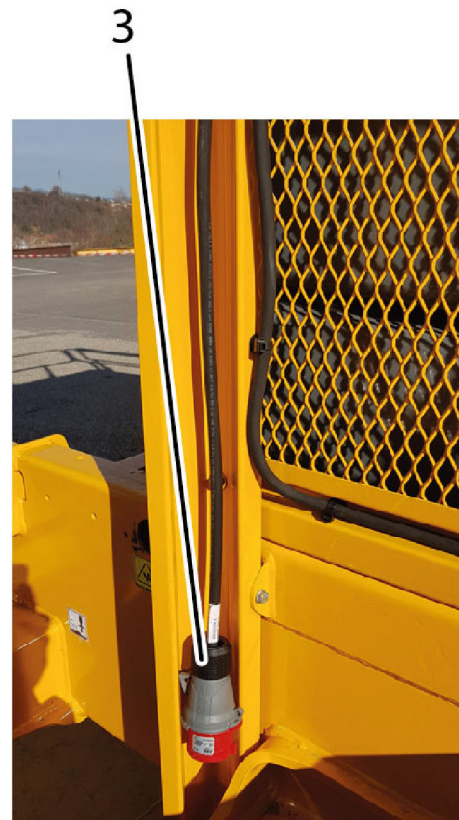
**3.6 Specific decals**

B.4 -Decals and markings locations.

4 Fast Charge

4.1 Description

This option is designed to charge the machine from an available three-phase 380 V (250V US) power network to minimise the machine's charge time.

N.B.-:IF THE STANDARD SOCKET AND FAST CHARGE SOCKET ARE BOTH CONNECTED, THE MACHINE WILL AUTOMATICALLY SELECT THE CHARGE OPTION (NORMAL OR FAST) BASED ON THE FIRST SOCKET CONNECTED.

Only elevation movements are authorized

4.2 Safety precautions



- Do not expose electrical components to direct contact with a water beam or a high pressure cleaner.
- Never replace the charging cable without written permission from HAULOTTE®.
- Ensure that the mains supply is suitable for your requirements.
- The power supply must comply with the electrical standards in force.



Ensure that:

- The vents on the battery compartment must not be obstructed.
- Cables must not be damaged.
- Sockets and cables must not be immersed in water or any other liquid

4.3 Specifications

	CE, UKCA, AS and EAC standards	ANSI and CSA standards
Type	3 (Phase - Neutral - Ground)	
Calibre	16 A	
Voltage	380 V	250 V
Charging time - 100% (For machines fitted with lead batteries)	Between 7 h and 12 h	
Charging time - 100% (For machines equipped with the lithium-ion battery option)	Between 3 h and 4 h	

4.4 Operation



Marking	Description
1	Charger - Fast charge option
2	Three-phase connection box
3	Power plug (380V)

Connect the 380 V (250V US) power cable to the socket (3) located on the machine.

5 Plate holder/Tube holder

5.1 Description

This accessory is an assembly designed to transport plates, pipes and tubes. This accessory is composed of 2 supports positioned and attached on the guardrails of the platform extensions. This accessory is held in position by means of pins.

The plates, tubes or pipes must be positioned on the supports and firmly attached to them using fasteners such as lashing straps (not provided).

5.2 Characteristics

Specifications	SI	Imp.
Weight of the carrier	2 x 19 kg	41.88 lb
Maximum usage load	400 kg	881.84 lb
Maximum load surface	1,2 m x 3,05 m= 3,66 m ²	3 ft 11 in x 10 ft = 39.39 sq ft
Max. dimensions of the plates/panels	1,2 m x 3,05 m	3 ft 11 in x 10 ft
Max. dimensions of the tubes/pipes	7,5 m	24 ft 7 in
Distance between the 2 supports:		
- Closed extension (Minimum)	- 269 cm	- 106 in
- Extensions open (maxi)	- 524 cm	- 167 in
Maximum wind speed allowed	45 km/h	27 mph
Maximum number of people authorised on the work platform when the accessory is in use	3	

5.2.1 Plate holder usage

- Maximum width: 120 cm / 48 in
- Minimum width: 81 cm / 32 in



5.2.2 Tube holder usage

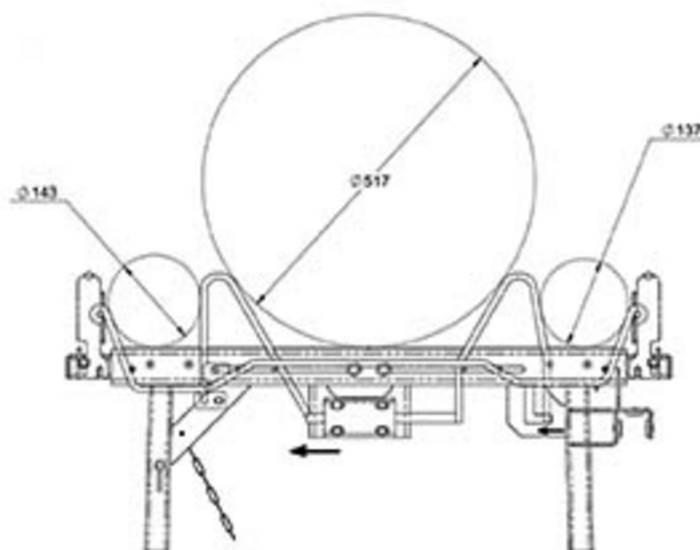

5.3 Safety precautions

- Read and understand all the instructions before using the accessory.
- This accessory is designed to transport plates, panels, tubes and pipes. Do not use this attachment for transporting other types of load.
- Do not load the accessory beyond its maximum usage load.
- Ensure that the equipment is correctly attached using suitable means of securing.
- Do not exceed the nominal capacity of the platform including:
 - The weight of the accessory.
 - The weight of the load on the accessory.
 - The weight of the operators.
 - The weight of the tools and any other equipment on the work platform.



Risk of overturning the machine:

- Do not load plates, panels, tubes or pipes the surface of which exceeds the maximum authorised surface. Exposing an additional surface area to the wind reduces machine stability.
- Do not install any other attachments that increase the surface area exposed to the wind.
- Do not use the machine if the wind speed exceeds the authorized limit of the attachment.
- The cradles should always be positioned such that they are within the platform.
- Position the bottom end of the cradles such that they are resting on the platform floor.



Risk of crushing and collision:

- The tubes or plates installed on the equipment can modify the overall size of the machine. When maneuvering, ensure you maintain a safe distance between the load and the obstacles in the work environment.

5.4 Pre-operation inspection



- Check that there are no cracks or other damage on the supports.
- Check that the supports are correctly attached to the platform (Ensure fastening screws are tightened and pins correctly positioned).
- Check that the legs of the supports rest completely flat on the platform.
- Check that the label giving information about the machine and equipment is present and legible.

- Ensure that the means for fastening and securing the loads (e.g. straps) are in good condition and well-maintained.
- Check that the positioning of the load and the supports does not block the work platform controls and access.
- Check that the positioning of the supports and the load does not reduce visibility during manoeuvres in the working environment.

5.5 Disassembly - Assembly

N.B.:-THE 2 SUPPORTS ARE POSITIONED ON THE OPPOSITE SIDE TO THE PLATFORM CONTROL BOX. THE 2 SUPPORTS ARE LOCATED ON THE EXTENSIONS AND THE EXTENSIONS CAN BE MOVED WHEN THE OPTION IS INSTALLED. HOLES ARE PROVIDED ON THE GUARDRAILS TO ATTACH THE SUPPORTS. A PLACE IS AVAILABLE FOR EACH SUPPORT.

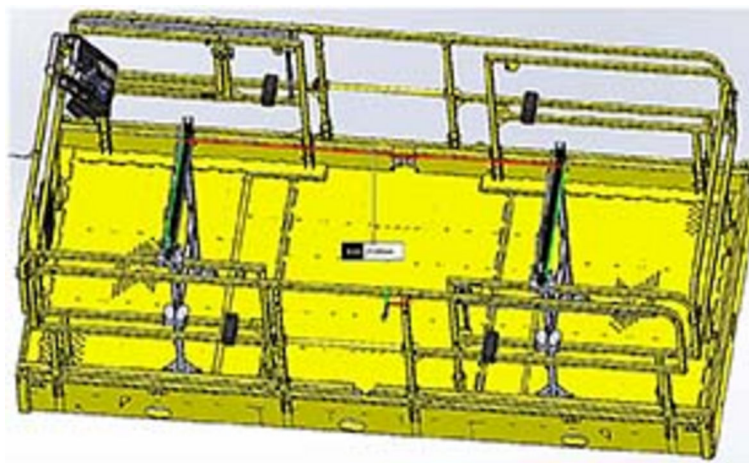

- Attach the supports to the guardrails on the opposite side to the platform control box.
- A space of 500 mm / 20 in must be left between the support and the guardrail.



- Lock the guardrail supports using the pins.

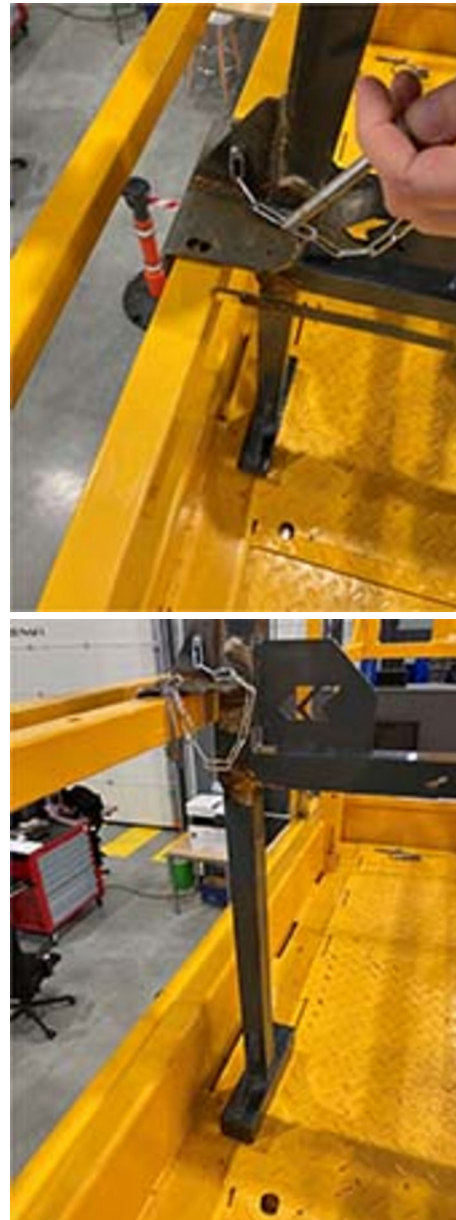

N.B.:--THE SUPPORTS ARE REMOVED IN REVERSE ORDER TO INSTALLATION.

5.6 Operation

5.6.1 Plate/panel holder version

- Pull on the indexing pin to unlock the extensions.
- The finger automatically engages in the authorised positions.
- Ensure that the finger is locked before loading up the supports.

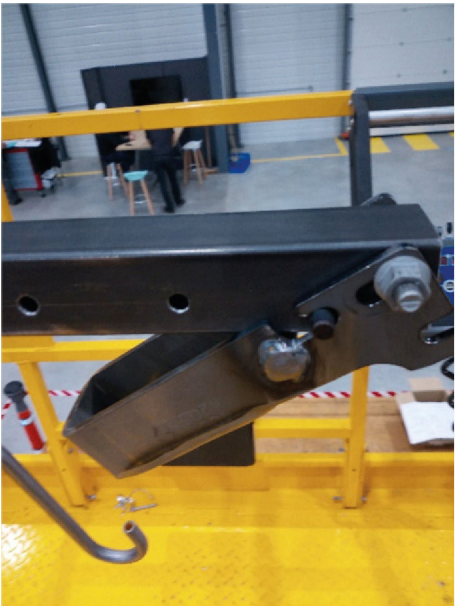

Operate the plate stop to place it in different positions.

Plate/panel holder position	Tube/pipe holder position - Transport position
	

5.6.2 Tube/pipe holder version

- Unlock the support from its seating in order to operate it.
- Lift the support manually.



- Lock the support in its seating.



- Secure the support using pins.



5.7 Strapping (Strap not provided)

- Lift the plate stop to a vertical position.



- The supports have pins allowing lashing straps to be attached



Ensure that loads are lashed to the equipment before moving the machine.



5.8 Storage of the supports on the platform

- Group the 2 supports at the rear of the platform in the opposite corner to the platform control box.
- The 2 supports are attached and locked on the guardrail using a pin.

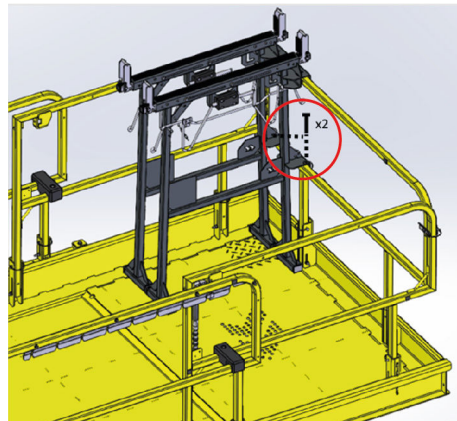

5.9 Folding guardrails if machine equipped with plate/tube holder support

Storage of the supports on the work platform for transport:

- Position the supports in the centre of the platform (not on the extensions).



Assembly folded:

-  D 5.4 - Folding guardrails



6 Activ'Shield Bar Scissors - Secondary guarding system (if the function is present and the device is installed in its support)

6.1 Description



General Specification Activ'Shield Bar Scissors:

- The Activ'Shield Bar Scissors system is a device designed to reduce the risk of crushing against the control console and guardrail when the platform moves into confined spaces.
- This device is complementary to the existing operator protection including the enable switch system (Trigger of joystick, Foot Switch and Enable Switch on platform control box).
- The Activ' Shield Bar Scissors system is activated when the console is in its support and when:
 - The platform is rising.
 - The platform is in stowed position and reversing.



This system does not relieve the operator from the responsibilities of learning and practicing the principles of safe use and operation of the machine as provided by the manufacturer's instructions, employer's safety rules and worksite regulations.



If the console is not in its support, the high speed functions are deactivated.

6.2 Characteristics



Marking	Description
1	Carrier
2	Activation bar

6.3 Safety precautions



It is mandatory to ensure that the Activ'Shield Bar Scissors is functional at each start-up of the machine.



Do not use the Activ'Shield Bar Scissors as a handhold. This could result in an inadvertent triggering of the Activ' Shield Bar.

6.4 Pre-operation inspection



- If any item on the checklist is marked NO during the inspection; machine must be tagged and locked out and placed out of service.
- DO NOT operate the machine until all identified items are corrected and it has been declared safe for operation.

In addition to all the functional tests specific to the machine and to ensure that the ActivShield Bar Scissors system operates correctly, carry out the following operations:

Description	Yes	No
- Check that the ActivShield Bar Scissors parts are present and in good condition		
- Is the control console correctly assembled according to the labels?		
- Does the control console lock automatically?		
Set the console into its support:		
- Move the detection bar until it comes into contact with the console: <ul style="list-style-type: none"> • Does detection bar go all the way down? • Does the detection bar return to its initial position? 		
Machine stowed:		
- Check the speed reduction: <ul style="list-style-type: none"> • Console out of its support, perform a lifting movement and verify that the speed is reduced. Ensure that the activation of the switch ActivShield Bar Scissors (29) does not change the movement speed • Console in its support, perform a lifting movement and verify that the speed is reduced. Ensure that the activation of the switch ActivShield Bar Scissors (29) accelerates the raising speed. • Select high-speed drive: Does speed selection automatically switch to medium speed? • Is high speed in forward gear accessible when the control console is in its support? 		
- Position the control console in its support: The ActivShield Bar Scissors indicator light is off		
- With the control console inserted into its support, perform a lifting movement: Does the ActivShield Bar Scissors indicator light switch on?		
- Machine unfolded: With the control console inserted into its support, perform a lifting movement: Press the bar: <ul style="list-style-type: none"> • Does the machine stop? • Does the blue flashing light switch on? • Is the buzzer triggered? • Is downward movement possible? • Is rearming possible? (1) 		

(1) :Reset = Bar lifted + Joystick returned to neutral

6.5 Operation

6.5.1 Travel speed limitation (ActivShield Bar Scissors option)

The machine has 3 drive speeds:

- Low speed (27)
- Middle speed (26)
- Fast speed (25)

2 other speeds are activated automatically depending on the conditions of use:

- Micro-speed
- Nano speed
- The electronic speed controller controls travel speeds.
- The variable speed drive receives information from the control on the type of movements to be performed.
- The variable speed drive also manages the safety status.

Poor knowledge of the characteristics and operation of the machine can lead the operator to think that a normal safety operation is a malfunction.

Machine stowed (Transport position) :

- The top control console is attached to its support (Normal operation) :
 - All travel speeds (PV, MV, GV) are permitted in forward mode. Only (PV, MV) are available in reverse.
 - The ActivShield Bar Scissors system is active (The ActivShield Bar Scissors indicator light switches on) .
- The upper control console is not in its support:
 - The ActivShield Bar Scissors system is inactive (ActivShield Bar Scissors indicator light is off) .
 - Only low and average speeds (PV, MV) are permitted in the 2 directions.
 - Selecting high speed (GV) automatically activates average speed (MV) .

Machine unfolded (Out of transport position) :

- The top control console is attached to its support (Normal operation) :
 - The ActivShield Bar Scissors system is active in reverse.
 - Whatever the speed selected:
 - Forward movement is done at "Micro Speed".
 - Rear movement is done at "Nano Speed".
- The upper control console is not in its support:
 - The ActivShield Bar Scissors system is inactive (ActivShield Bar Scissors indicator light is off) .
 - Only "Nano Speed" is active in the 2 movement directions.

6.5.2 Raising speed limitation (ActivShield Bar Scissors option)

The machine has 2 speeds that activate automatically depending on the conditions of use:

- Standard speed
- Safe speed

The top control console is attached to its support (Normal operation) :

- Pressing and holding the ActivShield Bar Scissors (29) button activates the standard raising speed and the ActivShield Bar Scissors system is active (The ActivShield Bar Scissors indicator light switches on) .
- Without pressing the ActivShield Bar Scissors button, the safe raising speed is activated and the ActivShield Bar Scissors system is active (The ActivShield Bar Scissors indicator light switches on) .
- When the machine is in the stowed position, the ActivShield Bar Scissors indicator light is off. When raising, the ActivShield Bar Scissors indicator light is on.

The upper control console is not in its support:

- The ActivShield Bar Scissors system is inactive (ActivShield Bar Scissors indicator light is off) .
- Only the safe raising speed is activated (ActivShield Bar Scissors indicator light is off) .

6.6 Specific decals

 B 5 - Decals and markings locations

6.7 Insert the console into its support

Activ' Shield Bar Scissor instructions

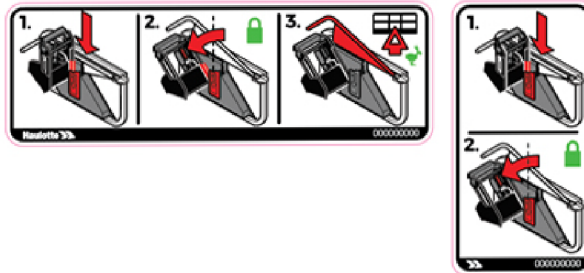

1 - Locate notches (1) and (2) on the support Activ' Shield Bar Scissor.



2 - On the console, locate the identifying mark (1).



3 - Position mark (1) on the control panel vertically in mark (1) of the support.



4 - Tilt the control console and snap it into the position marked (2) on support Activ' Shield Bar Scissor.



5 - To remove the console, carry out the steps in reverse order. Press on the lock to unlock it.

7 Central tube holder

7.1 Description

This accessory is an assembly designed to transport pipes, tubes. This accessory consists of 2 brackets positioned and fixed on the platform (Extensions extended) . This accessory is held in position using 4 screws per bracket.

The pipes or tubes must be positioned on the brackets and securely attached to them using a fastening device such as a lashing strap (strap supplied).

7.2 Characteristics

Specifications	SI	Imp.
Weight of the carrier	2 x 50 kg	2 x 110 lb
Maximum usage load	300 kg	660 lb
Maximum load surface	0,3 m x 6,50 m= 3 m ²	1 ft x 21 ft 3 in = 32,3 sq.ft
Max. dimensions of the tubes/pipes	6,5 m	24 ft 3 in
Distance between the 2 supports	232 cm	92 in
Height adjustment dimensions	From 96 cm to 136 cm	From 38 in to 54 in
Maximum wind speed allowed	45 km/h	28 mph
Maximum number of people authorised on the work platform when the accessory is in use	4	

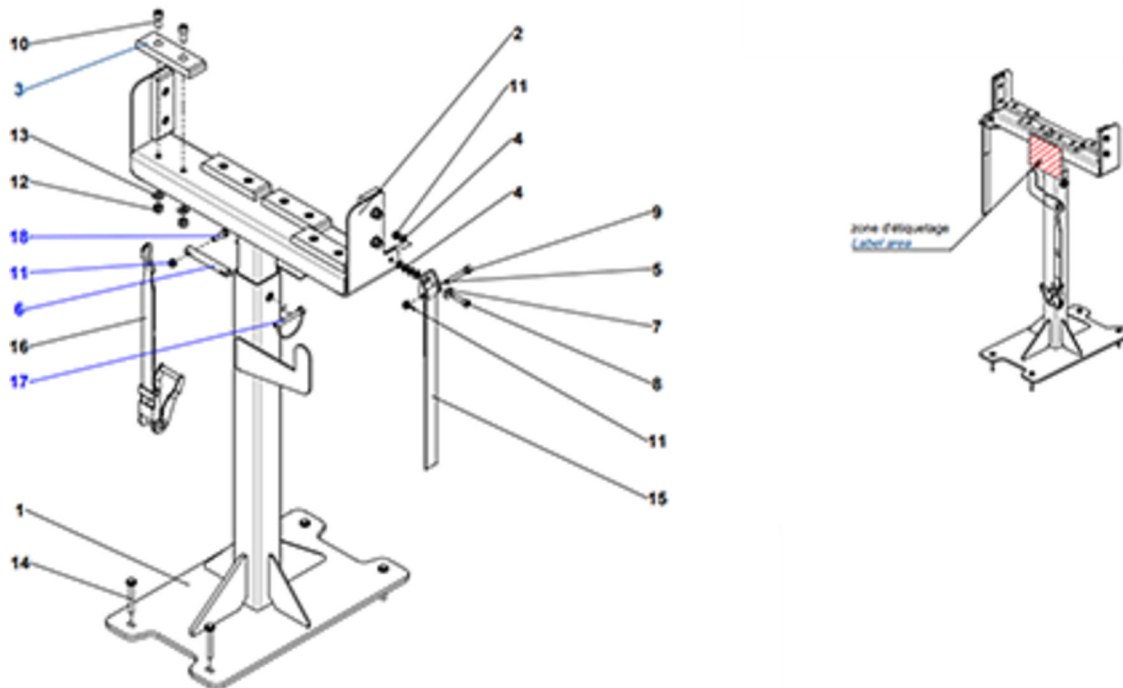

G - Options

Mark	Description
1	Fixed mast box
2	Jib crane
3	Wear pad
4	Flat washer
5	Carrier
6	Pinning axle
7	Flat washer
8	Screw CHC
9	Screw CHC
10	Screw CHC
11	Self-locking nut
12	Self-locking nut
13	Flat washer
14	Shoulder screw
15	Fixing strap
16	Fixing strap
17	Roll pin
18	Screw H

7.3 Safety precautions

- Read and understand all the instructions before using the accessory.
- This accessory is designed to transport pipes, tubes. Do not use this attachment for transporting other types of load.
- Do not load the accessory beyond its maximum usage load.
- Ensure that the equipment is correctly attached using suitable means of securing.
- Do not exceed the nominal capacity of the platform including:
 - The weight of the accessory.
 - The weight of the load on the accessory.
 - The weight of the operators.
 - The weight of the tools and any other equipment on the work platform.



Risk of overturning the machine:

- Do not load pipes or tubes whose surface exceeds the maximum permitted surface. Exposing an additional surface area to the wind reduces machine stability.
- Do not install any other attachments that increase the surface area exposed to the wind.
- Do not use the machine if the wind speed exceeds the authorized limit of the attachment.
- The cradles should always be positioned such that they are within the platform.
- For better operating comfort, choose the lowest possible boom height.



Risk of crushing and collision:

- Open extensions, and pipes or tubes installed on the equipment change the overall machine footprint (Overall length and height of the machine increased) . When maneuvering, ensure you maintain a safe distance between the load and the obstacles in the work environment.

7.4 Pre-operation inspection



- Check that there are no cracks or other damage on the supports.
- Check that the supports are correctly attached to the platform (Ensure fastening screws are tightened and pins correctly positioned) .
- Check that the legs of the supports rest completely flat on the platform.
- Check that the label giving information about the machine and equipment is present and legible.
- Ensure that the means for fastening and securing the loads (e.g. straps) are in good condition and well-maintained.
- Check that the positioning of the load and the supports does not block the work platform controls and access.
- Check that the positioning of the supports and the load does not reduce visibility during manoeuvres in the working environment.

7.5 Disassembly - Assembly

N.B.--THE 2 BRACKETS ARE POSITIONED IN THE CENTRE OF THE PLATFORM. THE 2 BRACKETS ARE POSITIONED ON THE FIXED PLATFORM. THE EXTENSIONS MUST BE OPEN. REMOVE THE BRACKETS TO RETRACT THE EXTENSIONS. AFTER DISASSEMBLY, STORE THE BRACKETS ON A PALLET, OUTSIDE THE PLATFORM.



G - Options

- The pre-installation of retaining plates under the platform is necessary for the option.



- Attach the mast feet (1) to the retaining plates using screws (14).

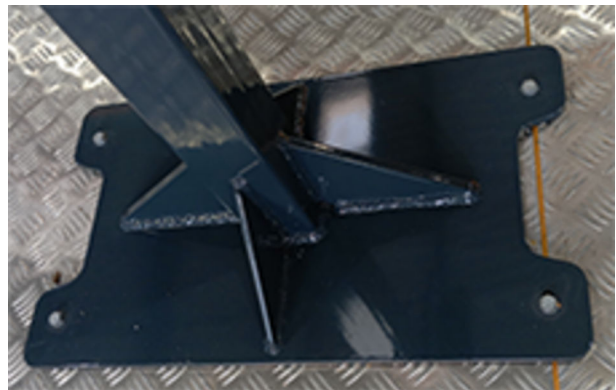
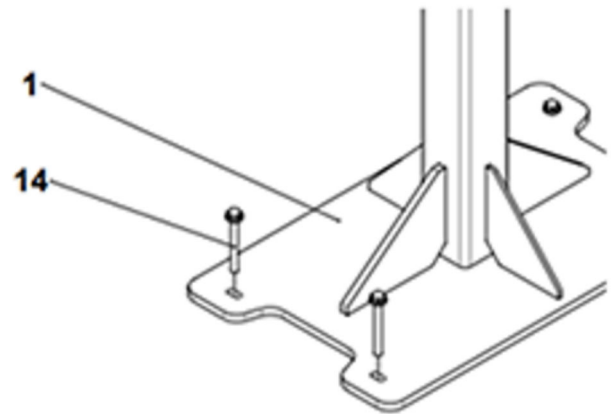

G - Options

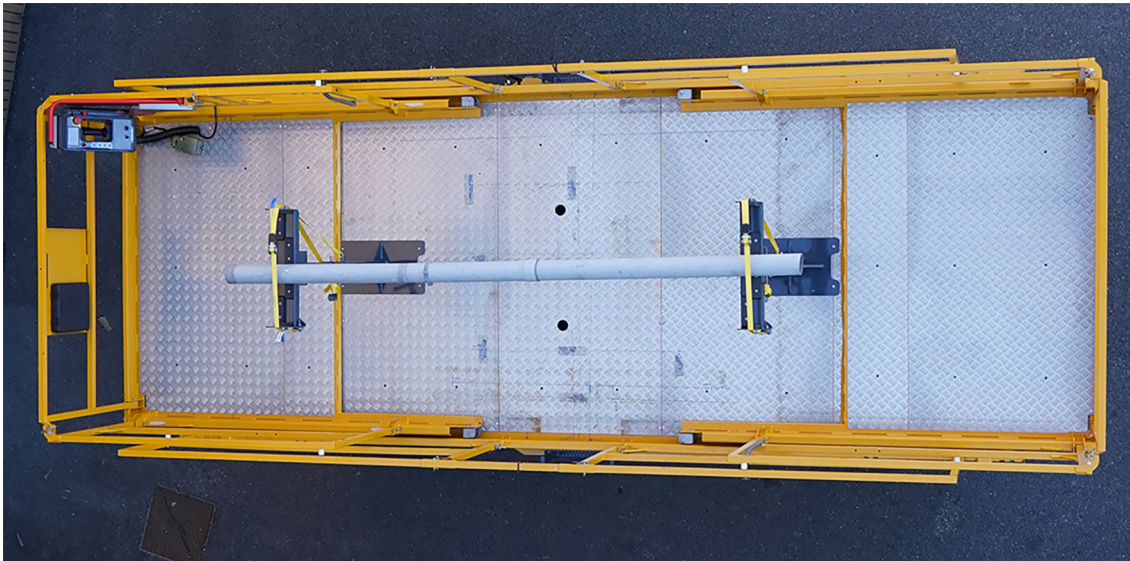

N.B.-:THE SUPPORTS ARE REMOVED IN REVERSE ORDER TO INSTALLATION.

7.6 Strapping (Supplied strap)

- The tube(s), pipes must be positioned on the brackets and securely attached to them with the straps supplied with the accessory.



- The supports have pins allowing lashing straps to be attached



Ensure that loads are lashed to the equipment before moving the machine.



7.7 Storage



Remove the brackets before transporting the machine. After disassembly, store the brackets on a pallet, outside the platform.

7.8 Folding guardrails if machine equipped with plate/tube holder support



Before folding down the guardrails, remove the 2 brackets. After disassembly, store the brackets on a pallet, outside the platform.

H - Other information

1	Conditions of warranty.....	3
2	Subsidiary contact information.....	4
2.1	California warning.....	5

H - Other information

1 Conditions of warranty

Our warranty conditions and extension contracts are now available on the websites of our sales network: www.haulotte.com







H - Other information

2 Subsidiary contact information

	<p>HAULOTTE FRANCE PARC DES LUMIERES 601 RUE NICEPHORE NIEPCE 69800 SAINT-PRIEST TECHNICAL Department: +33 (0)820 200 089 SPARE PARTS : +33 (0)820 205 344 FAX : +33 (0)4 72 88 01 43 E-mail : haulottefrance@haulotte.com www.haulotte.fr</p>		<p>HAULOTTE ITALIA VIA LOMBARDIA 15 20098 SAN GIULIANO MILANESE (MI) TEL: +39 02 98 97 01 FAX: +39 02 9897 01 25 E-mail : haulotteitalia@haulotte.com www.haulotte.it</p>		<p>HAULOTTE INDIA Unit No. 1205, 12th floor, Bhumiraj Costarica, Plot No. 1&2, Sector 18, Palm Beach Road, Sanpada, Navi Mumbai- 400 705 Maharashtra, INDIA Tel. : +91 22 66739531 to 35 E-mail : hlindia@haulotte.com www.haulotte.in</p>
	<p>HAULOTTE HUBARBEITSBÜHNEN GmbH Ehrenkirchener Strasse 2 D-79427 ESCHBACH TEL : +49 (0) 7634 50 67 - 0 FAX : +49 (0) 7634 50 67 - 119 E-mail : adv-gmbh@haulotte.com www.haulotte.de</p>		<p>HAULOTTE AUSTRALIA PTY Ltd 51 Port Link Drive DANDENONG - VIC - 3175 TEL : 1 300 207 683 FAX : +61 (0)3 9792 1011 E-mail : sales@haulotte.com.au www.haulotte.com.au</p>		<p>HAULOTTE DO BRASIL Av. Alameda Caiapós, 589 CEP: 06460-110 - TAMBORE BARUERI - SAO PAULO - BRASIL TEL : +55 11 4196 4300 FAX : +55 11 4196 4316 E-mail : haulottebrasil@haulotte.com www.haulotte.com.br</p>
	<p>HAULOTTE IBERICA C/ARGENTINA Nº 13 - P.I. LA GARENA 28806 ALCALA DE HENARES MADRID TEL : +34 902 886 455 TEL SAT : +34 902 886 444 FAX : +34 911 341 844 E-mail : iberica@haulotte.com www.haulotte.es</p>		<p>HAULOTTE POLSKA Sp. Z.o.o. UL. GRANICZNA 22 05-090 RASZYN - JANKI TEL : +48 22 720 08 80 FAX : +48 22 720 35 06 E-mail : haulottepolska@haulotte.com www.haulotte.pl</p>		<p>HAULOTTE MÉXICO, S.A. de C.V. Calle 40 SUR ESQUINA 13 ESTE No. S/N Colonia CIVAC, JUITEPEC, MORELOS CP 62578 México TEL : +52 77 7321 7923 FAX : +52 77 7516 8234 E-mail : haulotte.mexico@haulotte.com www.haulotte.com.mx</p>
	<p>HAULOTTE in JAPAN SBJ ShinOsaka BLDG 3F 4-6-5 Nishinakajima Yodogawa-ku, Osaka, JAPAN, Post Code: 532-0011 TEL : +81 6 6795 9008 FAX : +81 6 6795 9009 www.haulotte.com</p>		<p>HAULOTTE SINGAPORE Pte Ltd. No.26 CHANGI NORTH WAY, SINGAPORE 498812 Parts and service Hotline: +65 6546 6150 FAX : +65 6536 3969 E-mail : haulotteasia@haulotte.com www.haulotte.sg</p>		<p>HAULOTTE MIDDLE EAST FZE PO BOX 293881 Dubai Airport Free Zone DUBAI United Arab Emirates TEL : +971 (0)4 299 77 35 FAX : +971 (0) 4 299 60 28 E-mail : haulottemiddle-east@haulotte.com www.haulotte.ae</p>
	<p>HAULOTTE SCANDINAVIA AB Taljegårdsgatan 12 431 53 Mölndal SWEDEN TEL : +46 31 744 32 90 FAX : +46 31 744 32 99 E-mail : info@se.haulotte.com spares@se.haulotte.com www.haulotte.se</p>		<p>HAULOTTE TRADING (SHANGHAI) Co. Ltd. Room 606A, Tower 3, Ronshine Sunkwan Center Lane 77, Sunkun Road MINHANG DISTRICT SHANGHAI 201105 CHINA TEL : +86 21 6442 6607 FAX : +86 21 6442 6619 E-mail : haulotteshanghai@haulotte.com www.haulotte.cn</p>		<p>HAULOTTE ARGENTINA Ruta Panamericana Km. 34,300 (Ramal A Escobar) 1615 Gran Bourg (Provincia de Buenos Aires) Argentina TEL : +54 33 27 445991 FAX : +54 33 27 452191 E-mail : haulotteargentina@haulotte.com www.haulotte.com.ar</p>
	<p>HAULOTTE UK Ltd 1 Gravely Way Four Ashes Wolverhampton WV10 7GW ENGLAND TEL : +44 (0)1216 199753 FAX : +44 (0)1952 292758 E-mail : salesuk@haulotte.com www.haulotte.co.uk</p>		<p>HAULOTTE GROUP / BILJAX 125 TAYLOR PARKWAY ARCHBOLD, OH 43502 - USA TEL : +1 419 445 8915 FAX : +1 419 445 0367 Toll free : +1 800 537 0540 E-mail : sales@us.haulotte.com www.haulotte-usa.com</p>		<p>HAULOTTE NORTH AMERICA 3409 Chandler Creek Rd. VIRGINIA BEACH, VA 23453 - USA TEL : +1 757 689 2146 FAX : +1 757 689 2175 Toll free : +1 800 537 0540 E-mail : sales@us.haulotte.com www.haulotte-usa.com</p>
	<p>HAULOTTE NETHERLANDS BV Koopvaardijweg 26 4906 CV OOSTERHOUT - Nederland TEL : +31 (0) 162 670 707 FAX : +31 (0) 162 670 710 E-mail : info@haulotte.nl www.haulotte.nl</p>				<p>HAULOTTE CHILE Panamerica Norte Altura Km 21,5 Colina (Cruce c/Lo Pinto) Santiago (RM) TEL : + 562 2 3727630 E-mail : haulotte-chile@haulotte.com www.haulotte-chile.com</p>

2.1 California warning

For the US destined machines (ANSI and CSA standards)

<p>CALIFORNIA</p>  <p>Proposition 65 Warning</p> <p>Operating, servicing and maintaining a passenger vehicle or off-road vehicle can expose you to chemicals including engine exhaust, carbon monoxide, phthalates, and lead, which are known to the State of California to cause cancer and birth defects or other reproductive harm. To minimize exposure, avoid breathing exhaust, do not idle the engine except as necessary, service your vehicle in a well-ventilated area and wear gloves or wash your hands frequently when servicing your vehicle.</p> <p>For more information go to  www.P65Warnings.ca.gov/passenger-vehicle</p>
<p>CALIFORNIE</p>  <p>Avertissement de la Proposition 65</p> <p>L'exploitation, l'entretien et la maintenance d'un véhicule de tourisme ou d'un véhicule tout-terrain peuvent vous exposer à des produits chimiques, y compris les gaz d'échappement, le monoxyde de carbone, les phthalates et le plomb, identifiés par l'État de Californie comme pouvant causer le cancer et des malformations congénitales ou autres effets nocifs sur la reproduction. Pour limiter toute exposition: évitez de respirer les gaz d'échappement, ne laissez pas tourner le moteur au ralenti sauf si nécessaire, faites l'entretien du véhicule dans une zone bien aérée et portez des gants ou lavez vous fréquemment les mains lors de cette opération.</p> <p>Pour de plus amples informations, consulter  www.P65Warnings.ca.gov/passenger-vehicle</p>
<p>CALIFORNIA</p>  <p>Advertencia de la Proposición 65</p> <p>Operar, dar servicio y mantenimiento a un vehículo de pasajeros o vehículo todo terreno puede exponerle a químicos incluyendo gases del escape, monóxido de carbono, ftalatos y plomo, los cuales son conocidos por el Estado de California como causantes de cáncer y defectos de nacimiento u otros daños reproductivos. Para minimizar la exposición, evite respirar los gases del escape, no encienda el motor excepto si es necesario, dé servicio a su vehículo en un área bien ventilada y utilice guantes o lave sus manos frecuentemente cuando dé servicio a su vehículo.</p> <p>Para mayor información visite  www.P65Warnings.ca.gov/passenger-vehicle</p>

1 Intervention register..... 3

1 Intervention register

The intervention register keeps a record of maintenance and repair work carried out inside or outside the maintenance programme.

N.B.:-IN THE CASE OF A HAULOTTE SERVICES® INTERVENTION, THE QUALIFIED TECHNICIAN MUST INDICATE THE HAULOTTE SERVICES® INTERVENTION NUMBER.

Date	Type of intervention	Number of hours	Intervenor	Intervention number

