

UPT 150 Racelift 2.0

UPT 150 Racelift

Art.Nr.: 700098

- » Raises / lowers elements up to 150 kg
- » 1-man transport and mounting device for doors, windows, glass, metall and wood
- » Uncomplicated quick construction
- » Stroke ca. 1.050 mm
- » Rotating elements to 2.4 m length
- » Mast tilted by 90 ° to the left
- » Suction unit rotatable 360°
- » Handle adjustable in height and length
- » Non-slip handles
- » PU tires (ø 300 mm)

TECHNICAL DETAILS

Vacuum system	Hand held vacuum cups
Suction cups	2 units, ø 230 mm
Capacity	max. 150 kg
Dead weight	ca. 66 kg
Drive	Manuel
Options	Suction surface extention

POSITIONS

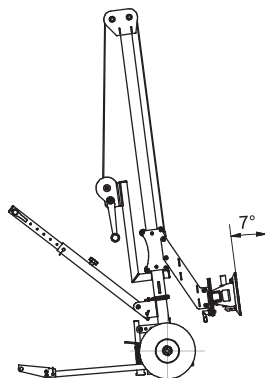
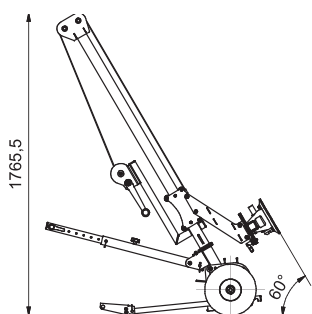

DIMENSIONS

