

PANORAMIC P 25.6



MERLO
AUSTRALIA

KEY SPECIFICATIONS

Total weight unladen with forks (kg)	4750
Maximum load capacity (kg)	2500
Maximum lift height (m)	5.9
Maximum forward reach (m)	3.3
Lift height at maximum capacity (m)	3.8
Forward reach at maximum load capacity (m)	1.1
Load capacity at maximum height (kg)	1500
Load capacity at maximum forward reach (kg)	900
Engine (make/number of cylinders)	Kubota/4
Tier 3 engine power (kW/hp)	55/75
Fuel capacity (l)	70
Maximum speed (kph)	36
Hydraulic system-Gear pump (bar-l/min)	210/84
Hydraulic oil capacity (l)	70
Electrical circuit (V)	12
Battery (Ah)	100
Cab compliant with ROPS/FOPS standards	✓
Electro/mechanical joystick controls	✓
Tac-Lock hydraulic attachment coupling	✓
Auxiliary boom hydraulics	✓
Two standard forks (1200mm)	✓
Hydrostatic transmission	✓
Finger touch direction control	✓
Inching pedal for precise control	✓
Permanent 4 wheel drive	✓
Four wheel steering	✓
Dry type disc brakes on all wheels	✓
Automatically locking parking brake	✓
12/75-18 tyres	✓
Rear differential lock	✓
Four cab working lights (2f & 2r)	✓
12V electrical on boom head	✓
Air suspension seat	✓
Front window protection	✓
Full size cab with air conditioning	✓
Stability control system	✓

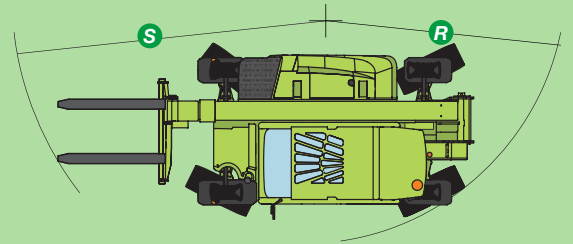
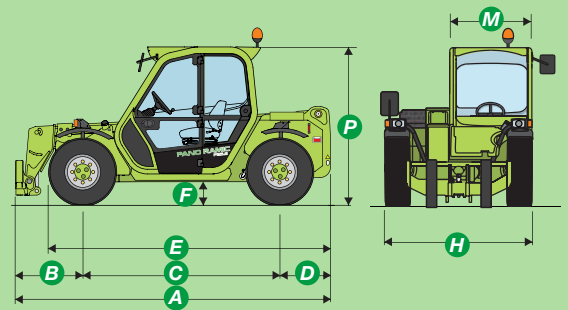

DIMENSIONS

A (mm)	3885
B (mm)	835
C (mm)	2450
D (mm)	650
E (mm)	3480
F (mm)	350
H (mm)	1800
M (mm)	995
P (mm)	1945
R (mm)	3370
S (mm)	4200

P25.6 Load Chart - Standard forks

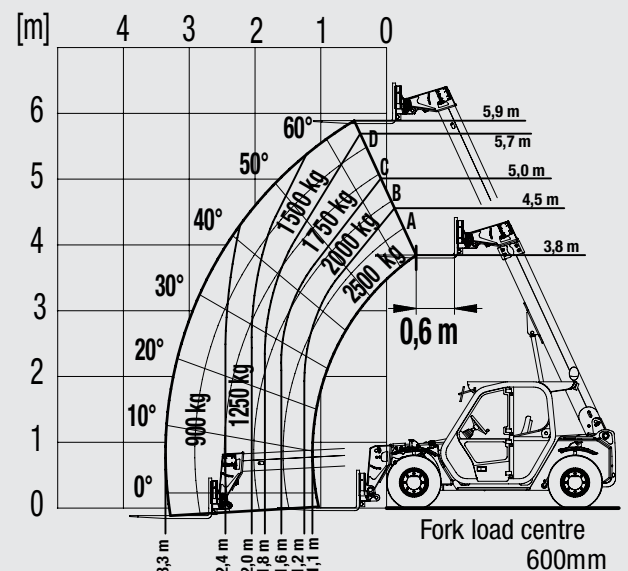

The Merlo P 25.6 is a compact telehandler designed for rental, construction and agricultural use. The P25.6 is ideal for bulk landscape suppliers, nurseries, poultry activities and materials handling. For added productivity, a large range of optional attachments including buckets, crane hooks, and fly jibs add to the versatility of the P25.6. Due to the flexibility and versatility of telehandlers they are usually operational for more hours, giving a higher rate of return, and reduce the need for other machines such as forklifts or front end tractors. The Merlo Panoramic P25.6 can move 2500 kg up to 6m height and travel up to 36 km/h. The P25.6 features a full size comfort cab in a telehandler less than 2 m high and 1.8 m wide. The 3 mode steering adds to the ease of operation. You benefit from easy to use versatile equipment, an increase in efficiency and productivity, and the safest telehandler with 50 years of specialist experience.



1300 657325
merloaustralia.com.au