

SELF-PROPELLED ROUGH-TERRAIN SCISSOR LIFTS

OPERATOR'S MANUAL

with Maintenance Information

(For JCPT1218RT / JCPT1418RT)



WARNING

THE MANUFACTURER SHALL NOT BE HELD LIABLE IN CASE OF FAULTS OR ACCIDENTS DUE TO NEGLIGENCE, INCAPACITY, INSTALLATION BY UNQUALIFIED TECHNICIANS AND IMPROPER USE OF THE MACHINE

DO NOT OPERATE THIS MACHINE UNTIL YOU READ AND UNDERSTAND ALL THE DANGERS, WARNINGS AND CAUTIONS IN THIS MANUAL

Part Number: SM0116111_Rev2.2



Zhejiang Dingli Machinery Co., Ltd.

Second Edition, February 2021 Printing

Version of the Record

Version of the Record

Version Number	Create Date
SM0116111_Rev1.0	2016-05
SM0116111_Rev2.0	2017-09
SM0116111_Rev2.1	2018-06
SM0116111_Rev2.2	2021-01

Important

Read, understand and obey these safety rules and operating instructions before operating this machine.

Only trained and authorized personnel shall be permitted to operate this machine. This manual should be considered a permanent part of your machine and should remain with the machine at all times. If you have any questions, please call DINGLI Machinery.

Contents

	Page
Safety Rules	1
Legend	8
Decals	9
Specifications	14
Control panel	16
Pre-operation Inspection	21
Workplace Inspection	23
Function Tests	24
Operating Instructions	29
Transport and Lifting Instructions	36
Maintenance	39
Schematic	67
Inspection and Repair Log	70

Owners, Users and operators:

We appreciate your choice of our machine for your application. Our number one priority is user safety, which is best achieved by our joint efforts. We feel that you make a major contribution to safety if you, as the equipment users and operators:

- 1 Comply with employer, job site and governmental rules.
- 2 Read, understand and follow the instructions in this and other manuals supplied with this machine.
- 3 Use good safe work practices in a commonsense way.
- 4 Only have trained / certified operators, directed by informed and knowledgeable supervision, running the machine.

If there is anything in this manual that is not clear or which you believe should be added, please contact us.

Contact us:

Zhejiang Dingli Machinery Co., Ltd.

1255 Baiyun South Road. Leidian Town.
Deqing Zhejiang

China

Tel: +86-572-8681688

Fax: +86-572-8681690

Web: www.cndingli.com

E-mail: market@cndingli.com

Safety Rules



Danger

Failure to obey the instructions and safety rules in this manual will result in death or serious injury.

Do Not Operate Unless:

- You learn and practice the principles of safe machine operation contained in this operator's manual.
 - 1 Avoid hazardous situations.**
 - Know and understand the safety rules before going on to the next section.**
 - 2 Always perform a pre-operation inspection.
 - 3 Always perform function tests prior to use.
 - 4 Inspect the workplace.
 - 5 Only use the machine as it was intended.
- You read, understand and obey the manufacturer's instructions and safety rules— safety and operator's manuals and machine decals.
- You read, understand and obey employer's safety rules and worksite regulations.
- You read, understand and obey all applicable governmental regulations.
- You are properly trained to safely operate the machine.

Decal Legend

DINGLI product decals use symbols, color coding and signal words to identify the following:



Safety alert symbol—used to alert personnel to potential personal injury hazards. Obey all safety messages that follow this symbol to avoid possible injury or death.

▲ DANGER Red—used to indicate the presence of an imminently hazardous situation which, if not avoided, will result in death or serious injury.

▲ WARNING Orange—used to indicate the presence of a potentially hazardous situation which, if not avoided, could result in death or serious injury.

▲ CAUTION Yellow with safety alert symbol- used to indicate the presence of a potentially hazardous situation which, if not avoided, may cause minor or moderate injury.

NOTICE Blue without safety alert symbol—used to indicate the presence of a potentially hazardous situation which, if not avoided, may result in property damage.

Safety Rules

The relevant conditions of using the equipment

The surface of work ground should be flat and hard with no obstacles in air and the safety distance between the equipment and high-tension line is adequate.

The environment temperature should be within -20°C~40°C; Height above sea level ≤1000m.

The environment humidity ≤ 90%.

Electrical power: AC 110~230V±10%, 50~60Hz.

Intended Use

This machine is intended to be used only to lift personnel, along with their tools and materials to an aerial work site.

Safety Sign Maintenance

Replace any missing or damaged safety signs. Keep operator safety in mind at all times. Use mild soap and water to clean safety signs. Do not use solvent-based cleaners because they may damage the safety sign material.

⚠ Electrocution Hazards

This machine is not electrically insulated and will not provide protection from contact with or proximity to electrical current.

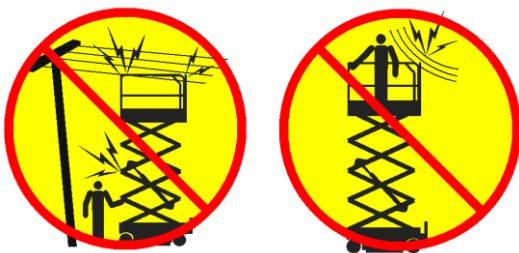

Maintain safe distances from electrical power lines and apparatus in accordance with applicable governmental regulations and the following chart.

Voltage Phase to Phase	Minimum Safe Approach Distance Meters
0 to 300V	Avoid Contact
300V to 50kV	3.05
50kV to 200kV	4.60
200kV to 350kV	6.10
350kV to 500kV	7.62
500kV to 750kV	10.67
750kV to 1000kV	13.72

Allow for platform movement, electrical line sway or sag and beware of strong or gusty winds.

Keep away from the machine if it contacts energized power lines. Personnel on the ground or in the platform must not touch or operate the machine until energized power lines are shut off.

Do not operate the machine during lightning or storms.

Do not use the machine as a ground for welding.

⚠ Tip-over Hazards

Occupants, equipment and materials must not exceed the maximum platform capacity or the maximum capacity of the platform extension.

Maximum capacity – JCPT1218RT

Maximum occupants (Indoor use)	4
Maximum occupants (Outdoor use)	2
Platform allowable maximum load	454kg
Extension deck allowable maximum load	136kg

Maximum capacity – JCPT1418RT

Maximum occupants (Indoor use)	3
Maximum occupants (Outdoor use)	2

Safety Rules

Platform allowable maximum load 363kg

Extension deck allowable maximum load 136kg

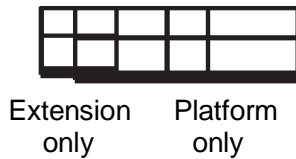

Work Area Safety

Do not raise the platform unless the machine is on a firm, level surface.

Do not drive over 0.45 km/h with the platform raised.



Do not depend on the tilt alarm as a level indicator. The tilt alarm sounds on the chassis and in the platform when the machine is on a slope.

If the tilt alarm sounds:

Lower the platform. Move the machine to a firm, level surface. If the tilt alarm sounds when the platform is raised, use extreme caution to lower the platform.

For outdoor use machine, do not raise the platform when wind speeds may exceed 12.5 m/s. If wind speeds exceed 12.5 m/s when the platform is raised, lower the platform and do not continue to operate the machine.

Do not operate the machine in strong or gusty winds. Do not increase the surface area of the platform or the load. Increasing the area exposed to the wind will decrease machine stability.

Do not use the platform controls to free a platform that is caught, snagged or otherwise prevented from normal motion by an adjacent structure. All personnel must be removed from the platform before attempting to free the platform using the ground controls.

Use extreme care and slow speeds while driving the machine in the stowed position across uneven terrain, debris, unstable or slippery surfaces and near holes and drop-offs.

Do not drive the machine on or near uneven terrain, unstable surfaces or other hazardous conditions with the platform raised.

Do not push off or pull toward any object outside of the platform.



Maximum allowable manual force

Model	Application	manual force	Maximum occupants
JCPT1218RT	Outdoor	400N	2
	Indoor	400N	4
JCPT1418RT	Outdoor	400N	2
	Indoor	400N	3

Do not use the machine as a crane.

Do not place or attach fixed or overhanging

Safety Rules

loads to any part of this machine.

Do not push the machine or other objects with the platform.

Do not contact adjacent structures with the platform.

Do not alter or disable the limit switches.

Do not tie the platform to adjacent structures.

Do not place loads outside the platform perimeter.



Do not alter or disable machine components that in any way affect safety and stability.

Do not replace items critical to machine stability with items of different weight or specification.

Do not modify or alter an aerial work platform without prior written permission from the manufacturer. Mounting attachments for holding tools or other materials onto the platform, toe boards or guard rail system can increase the weight in the platform and the surface area of the platform or the load.

Do not place ladders or scaffolds in the platform or against any part of this machine.

Do not transport tools and materials unless they are evenly distributed and can be safely handled by person(s) in the platform.

Do not use the machine on a moving or mobile surface or vehicle.

Be sure all tires are in good condition, air-filled tires are properly inflated and lug nuts are properly tightened.

▲ Crushing Hazards

Keep hands and limbs out of scissors.

Keep hands clear when folding rails.

Use common sense and planning when operating the machine with the controller from the ground. Maintain safe distances between the operator, the machine and fixed objects.

Maintain a firm grasp on the platform rail when removing the rail pins. Do not allow the platform guard rails to fall.

▲ Operation on Slopes Hazards

Do not drive the machine on a slope that exceeds the slope and side slope rating of the machine.

Slope rating applies to machines only in the stowed position.

Model	Maximum slope rating stowed position	Maximum side slope rating stowed position
JCPT1218RT	40%	40%
JCPT1418RT	40%	40%

Note: Slope rating is subject to ground conditions and adequate traction.

▲ Fall Hazards

The guard rail system provides fall protection. During operation, occupants in the platform must wear a full body harness with a lanyard attached to an authorized lanyard anchorage point. Attach only one (1) lanyard per lanyard anchorage point.

Do not sit, stand or climb on the platform guard rails. Maintain a firm footing on the platform floor at all times.



Safety Rules

Do not climb down from the platform when raised.

Keep the platform floor clear of debris.

Close the entry gate before operating.

Do not operate the machine unless the guard rails are properly installed and the entry is secured for operation.

Do not enter or exit the platform unless the machine is in the stowed position.

▲ Collision Hazards

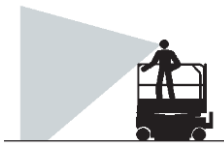

Be aware of limited sight distance and blind spots when driving or operating.

Be aware of extended platform position(s) when moving the machine.

Check the work area for overhead obstructions or other possible hazards.



Be aware of crushing hazards when grasping the platform guard rail.

Operators must comply with employer, job site and governmental rules regarding use of personal protective equipment.

Observe and use color-coded direction arrows on the platform controls and platform decal plate for drive and steer functions.

Do not operate a machine in the path of any crane or moving overhead machinery unless the controls of the crane have been locked out and/or precautions have been taken to prevent any potential collision.

No stunt driving or horseplay while operating a machine.

Do not lower the platform unless the area below is clear of personnel and obstructions.



Limit travel speed according to the condition of the ground surface, congestion, slope, location of personnel, and any other factors which may cause collision.

▲ Component Damage Hazards

Do not use any battery or charger greater than 12V to charge the battery.

Do not use the machine as a ground for welding.

▲ Explosion and Fire Hazards

Do not start the engine if you smell or detect liquid petroleum gas (LPG), gasoline, diesel fuel or other explosive substances.

Do not refuel the machine with the engine running.

Refuel the machine and charge the battery only in an open, well-ventilated area away from sparks, flames and lighted tobacco.

Do not operate the machine in hazardous locations or locations where potentially flammable or explosive gases or particles may be present.

Do not spray ether into engines equipped with glow plugs.

Safety Rules

⚠ Damaged Machine Hazards

Do not use a damaged or malfunctioning machine.

Conduct a thorough pre-operation inspection of the machine and test all functions before each work shift. Immediately tag and remove from service a damaged or malfunctioning machine.

Be sure all maintenance has been performed as specified in this manual.

Be sure all decals are in place and legible.

Be sure the operator's manual is complete, legible and in the storage container located in the platform.

⚠ Bodily Injury Hazard

Always operate the machine in a well-ventilated area to avoid carbon monoxide poisoning.

Do not operate the machine with a hydraulic oil or air leak. An air leak or hydraulic leak can penetrate and/or burn skin.

Improper contact with components under any cover will cause serious injury. Only trained maintenance personnel should access compartments. Access by the operator is only advised when performing a pre-operation inspection. All compartments must remain closed and secured during operation.

⚠ Outrigger Safety

Do not lower the outriggers unless the machine is on a firm surface. **If the ground does not meet the requirements specified of the relevant regulations, sufficient ground preparation shall be carried out in advance to confirm its safety before operation.** Avoid drop-offs, holes, unstable or slippery surfaces and other possible hazardous conditions.

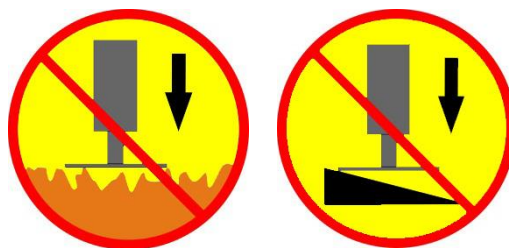

In case of special (soft or inclined) ground, the wood or steel pad suitable for the ground must be used under the support plate, and it must be firm and not cave in during the operation.

When using the backing plate, the backing plate must be of a solid structure that can fully withstand the pressure of the supporting leg. If the steel plate is set under the support plate, it should be used with small deformation.

When the auto level function is not being used and the outriggers are being lowered individually, the steer-end outriggers must be lowered first.

Do not raise the platform unless the machine is level. Do not set the machine up on a surface where it cannot be leveled using only the outriggers.

Do not raise the platform unless all four outriggers are properly lowered, the footpads are in firm contact with the ground and the machine is level.

Do not adjust the outriggers while the platform is raised.

Do not drive while the outriggers are lowered.

⚠ Battery Safety

⚠ Burn Hazard



Batteries contain acid. Always wear protective clothing and eye wear when working with

Safety Rules

batteries.

Avoid spilling or contacting battery acid.

Neutralize battery acid spills with baking soda and water.

⚠ Explosion Hazard



Keep sparks, flames and lighted tobacco away from batteries. Batteries emit explosive gas.

⚠ Electrocutation/ Hazard

Avoid contact with electrical terminals.

Lockout after Each Use

- 1 Select a safe parking location - firm level surface, clear of obstruction and traffic.
- 2 Lower the platform.
- 3 Turn the key switch to the off position and remove the key to secure from unauthorized use.
- 4 Push in the red Emergency Stop buttons to "off" position.
- 5 Push in the main power switch to "off" position.
- 6 Chock the wheels.

Legend

Legend

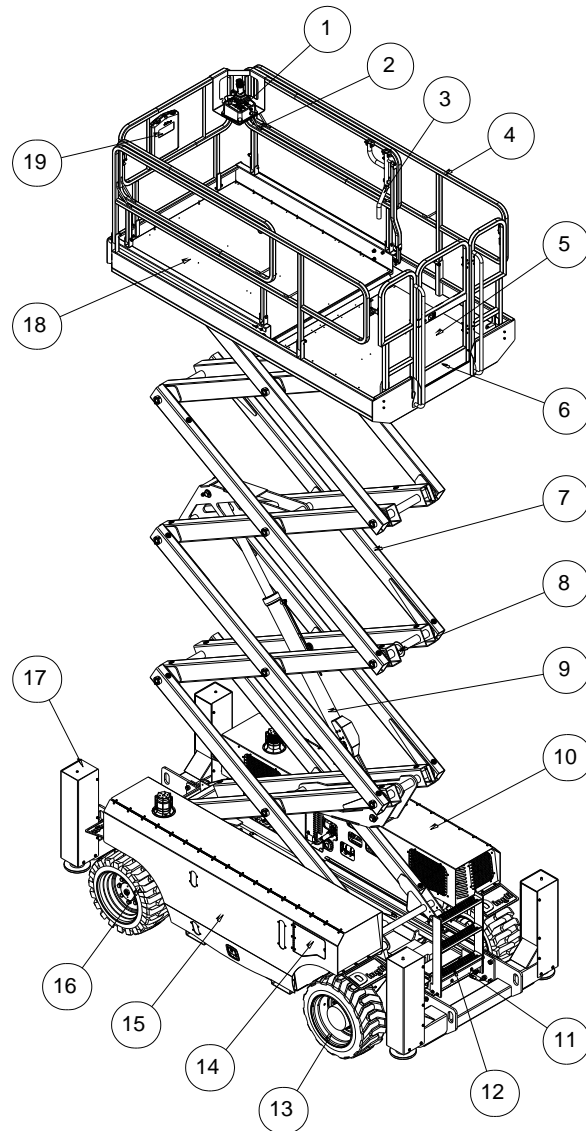

- | | |
|----------------------------------|------------------------------------|
| 1 Platform controls | 11 Emergency lowering knob |
| 2 Lanyard anchorage point | 12 Entry ladder |
| 3 Platform extension lock handle | 13 Non-steer tire |
| 4 Platform guard rails | 14 Ground controls |
| 5 Main Platform | 15 Hydraulic tank tray |
| 6 Platform entry gate | 16 Steer tire |
| 7 Scissor Arms | 17 Outrigger housing (if equipped) |
| 8 Safety arm | 18 Platform extension |
| 9 Lift Cylinder | 19 Manual storage container |
| 10 Engine tray | |

Decals**Decal Inspection**

Use the pictures on the next page to verify that all decals are legible and in place.

Below is a numerical list with quantities and descriptions.

No.	Part No.	Description	Qty.	Remark
1	09340001	Decal, Notice-Keep the manual with the machine	1	
2	09440119	Decal, Danger-Tip-over hazard, tilt-alarm	1	
3	09440001	Decal, Danger-General safety rules	1	
4	09340003	Decal, Instructions-Refer the operator to the instructions for use	2	
5	09440059	Decal, Label-Lanyard anchorage point	8	
6	09440073	Decal, Label-Capacity 454kg	1	JCPT1218RT
	09440074	Decal, Label-Capacity 363kg	1	JCPT1418RT
7	09430003	Decal, Danger-Keep away from moving parts	2	
8	09430001	Decal, Danger-Safety arm	2	
9	09420005	Decal, Warning-Collision hazard	4	
10	09310118	Decal, Instructions-Maximum wheel load 1930kg	4	JCPT1218RT
	09310120	Decal, Instructions-Maximum wheel load 2210kg	4	JCPT1418RT
11	09310004	Decal, Instructions-Emergency lower	1	
12	09310003	Decal, Instructions-Tie down point	4	
13	09310002	Decal, Instructions-Lift point	4	
14	09310122	Decal, Instructions-Maximum outrigger load 1930kg	4	JCPT1218RT
	09310124	Decal, Instructions-Maximum outrigger load 2210kg	4	JCPT1418RT
15	09410157	Decal, Symbols-Outrigger using warning	4	
16	09410069	Decal, Warning-Crushing hazard, outrigger	4	
17	09210021	Nameplate, Manufacturer serial number	1	
18	09310001	Decal, Instructions-Forklift pockets	4	
19	09410003	Decal, Warning-Inspected and operation properly	1	
20	09410071	Decal, Warning-Injection hazard	1	

Decals

No.	Part No.	Description	Qty.	Remark
21	09910006	Decal, Label-Cosmetic	1	
22	09320003	Decal, Instructions-Diesel	2	
23	09540001	Decal, Label-CE	2	
24	09440007	Decal, Caution-Max. manual force 400N	2	
25	09640015	Decal, Cosmetic-JCPT1218RT	2	JCPT1218RT
	09640016	Decal, Cosmetic-JCPT1418RT	2	JCPT1418RT
26	09410005	Decal, Danger-Do not alter or disable limit switch	1	
27	09310006	Decal, Notice-Main power switch operation	1	
28	09410001	Decal, Danger-Explosion/burn hazard	1	
29	09420011	Decal, Caution-High temperature	1	
30	09910005	Decal, Label-Cosmetic	1	
31	09310054	Decal, Instructions-Hydraulic	1	
32	09310053	Decal, Instructions-Lowest oil level	1	
33	09310052	Decal, Instructions-Highest oil level	1	

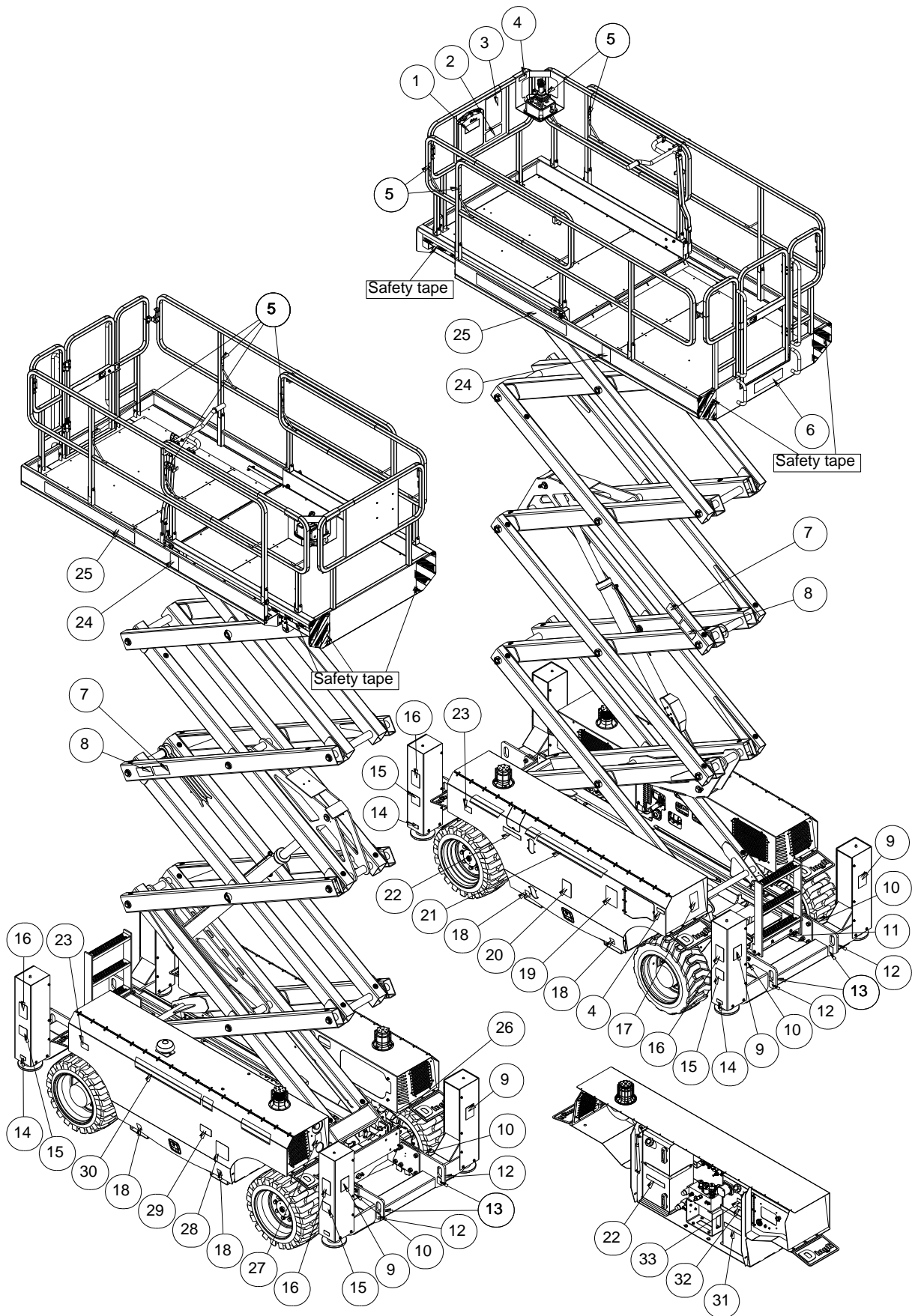

Decals

① 09340001



② 09440119

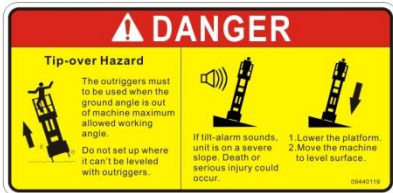

③ 09440001



④ 09340003



⑤ 09440059



⑨ 09420005



⑪ 09310004



⑫ 09310003



⑬ 09310002



⑦ 09430003



⑧ 09430001



⑩ 09310118



⑩ 09310120



⑭ 09310122



⑭ 09310124



⑯ 09410069



⑮ 09410157



⑥ 09440073

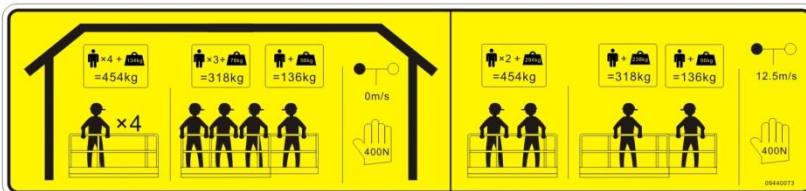

⑥ 09440074

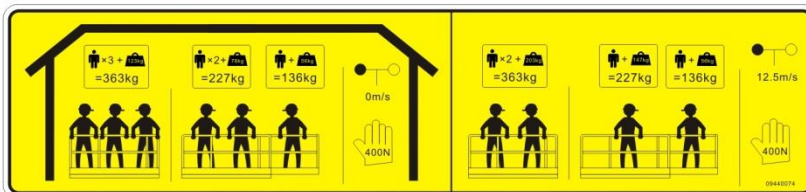

⑰ 09210021

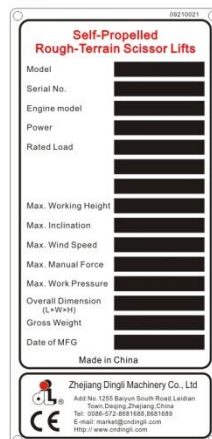

20 09910006



18 09310001



19 09410003

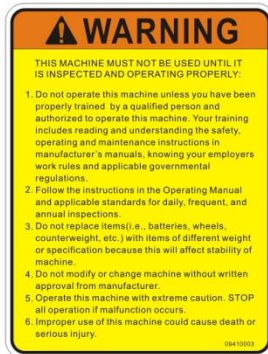

20 09410071



23 09540001



24 09440007

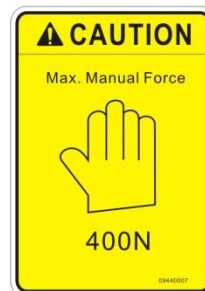

26 09410005



29 09420011



27 09310006

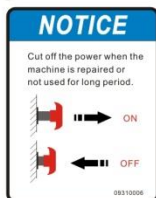

28 09410001



22 09320003



25 09640015

JCPT1218RT

25 09640016

JCPT1418RT

30 09910005



31 09310054



32 09310053



33 09310052



Specifications

Model JCPT1218RT

Height, working maximum	12m	Controls	Proportional
Height, platform maximum	10m	AC outlet in platform	Standard
Height, stowed maximum Rails up	2.59m	Maximum hydraulic pressure (functions)	240bar
Height, stowed maximum Rails folded	1.82m	Tire size - standard tires	Φ26×12-16.5
Width, standard tires	1.76m	Airborne noise emissions	<80dB
Length, platform retracted Models without outriggers	3.19m	Maximum sound level at normal operating workstations (A-weighted)	
Length, platform retracted Models with outriggers	3.84m	Gradeability	40%
Length, platform extended Models without outriggers	4.51m	Maximum working slope	X-1.5°, Y-3°
Length, platform extended Models with outriggers	4.81m	Drive speeds	
Platform dimensions Platform length × width	2.88×1.52m	Stowed, maximum	5.0km/h
Platform extension length	1.43m	Platform raised, maximum	0.45km/h
Maximum load capacity	454kg	Floor loading information	
Maximum wind speed	12.5m/s	Tire load, maximum	1930kg
Wheelbase	2.29m	Outrigger load, maximum	1930kg
Turning radius (outside)	4.60m	Tire contact pressure	945.5kPa
Turning radius (inside)	2.11m	Outrigger contact pressure	602kPa
Ground clearance	24cm	Occupied floor pressure	8.5kPa
Weight	See Serial Label	Note: Floor loading information is approximate and does not incorporate different option configurations. It should be used only with adequate safety factors.	
(Machine weights vary with option configurations)		Continuous improvement of our products is a DINGLI policy. Product specifications are subject to change without notice or obligation.	

Specifications**Model JCPT1418RT**

Height, working maximum	14.3m	Controls	Proportional
Height, platform maximum	12.3m	AC outlet in platform	Standard
Height, stowed maximum Rails up	2.74m	Maximum hydraulic pressure (functions)	240bar
Height, stowed maximum Rails folded	1.97m	Tire size - standard tires	Φ26×12-16.5
Width, standard tires	1.76m	Airborne noise emissions	<80dB
Length, platform retracted Models without outriggers	3.19m	Maximum sound level at normal operating workstations (A-weighted)	
Length, platform retracted Models with outriggers	3.84m	Gradeability	40%
Length, platform extended Models without outriggers	4.51m	Maximum working slope	X-1.5°, Y-3°
Length, platform extended Models with outriggers	4.81m	Drive speeds	
Platform dimensions Platform length × width	2.88×1.52m	Stowed, maximum	5.0km/h
Platform extension length	1.43m	Platform raised, maximum	0.45km/h
Maximum load capacity	363kg	Floor loading information	
Maximum wind speed	12.5m/s	Tire load, maximum	2210kg
Wheelbase	2.29m	Outrigger load, maximum	2210kg
Turning radius (outside)	4.60m	Tire contact pressure	1065kPa
Turning radius (inside)	2.11m	Outrigger contact pressure	678kPa
Ground clearance	24cm	Occupied floor pressure	9.5kPa
Weight	See Serial Label	Note: Floor loading information is approximate and does not incorporate different option configurations. It should be used only with adequate safety factors.	
(Machine weights vary with option configurations)		Continuous improvement of our products is a DINGLI policy. Product specifications are subject to change without notice or obligation.	

Control Panel

Ground Control Panel

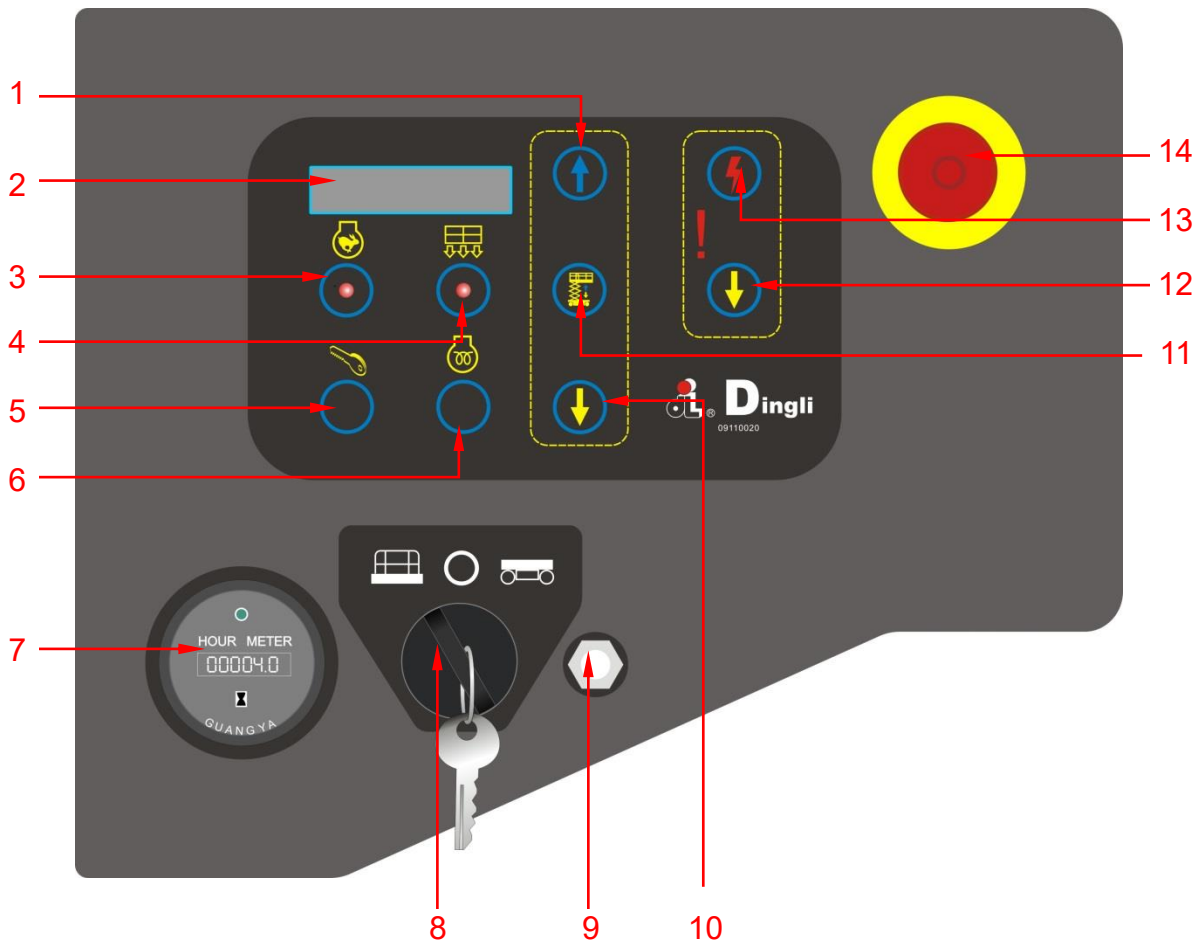

- | | |
|-----------------------------|--|
| 1 Platform up button | 8 Key switch |
| 2 Display | 9 Circuit breaker |
| 3 Engine idle select button | 10 Platform down button |
| 4 Overload indicator light | 11 Lift function enable button |
| 5 Engine start button | 12 Emergency lowering down button |
| 6 Engine glow plug button | 13 Emergency lowering down enable button |
| 7 Hour meter | 14 Red Emergency Stop button |

Control Panel

Ground Control Panel

1 Platform up button

Press this button and the platform will lift.

2 Display

Diagnostic readout

3 Engine idle select button

Press this button to select the engine idle setting. Light on indicates high idle is selected. Light off indicates low idle is selected.

4 Overload indicator light

Light on indicates when overloaded.

5 Engine start button

Press this button to start the engine.

6 Engine glow plug button

Press and hold this button to preheat engine.

7 Hour meter

The hour meter displays the number of hours the machine has operated.

8 Key switch

Turn the key switch to the platform position and the platform controls will operate.

Turn the key switch to the off position and the machine will be off. Turn the key switch to the base position and the ground controls will operate.

9 Circuit breaker**10 Platform down button**

Press this button and the platform will lower

11 Lift function enable button

Press this button to activate the lift function.

12 Emergency lowering down button

Press this button and the platform will lower

13 Emergency lowering down enable button

Press this button to activate the Emergency down function.

14 Red Emergency Stop button

Push in the red Emergency Stop button to the off position to stop all functions. Pull out the red Emergency Stop button to the on position to operate the machine.

Control Panel

Platform Control Panel

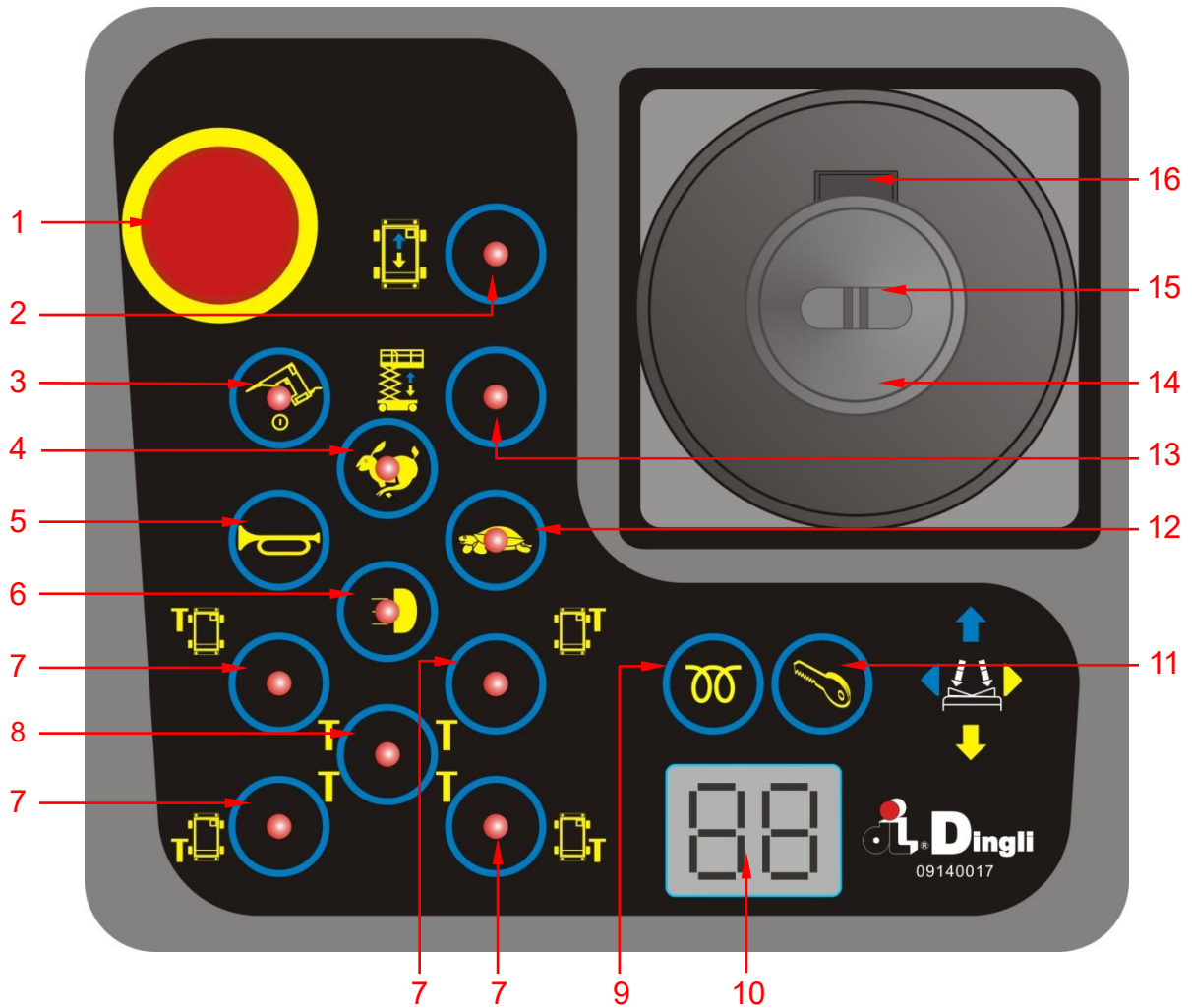

- | | |
|--|--|
| 1 Red Emergency Stop button | 9 Engine glow plug button |
| 2 Drive function select button | 10 LED readout screen |
| 3 Generator select button (if equipped) | 11 Engine start button |
| 4 Engine high speed idle select button | 12 Engine lower speed idle select button |
| 5 Horn button | 13 Lift function select button |
| 6 Light (if equipped) | 14 Proportional control handle |
| 7 Outrigger function enable button | 15 Thumb rocker switch |
| 8 Outrigger auto level button | 16 Function enable switch |

Control Panel

Platform Control Panel

1 Red Emergency Stop button

Push in the red Emergency Stop button to the off position to stop all functions. Pull out the red Emergency Stop button to the on position to operate the machine.

2 Drive function select button

Press this button to activate the drive function.

3 Generator select button (if equipped)

Press this button to turn the generator on. Indicator light will be on. Press the button again to turn the generator off.

4 Engine high speed idle select button

Press this button to select the engine idle setting. Light on indicates high idle is selected.

5 Horn button

Press this button and the horn will sound. Release the button and the horn will stop.

6 Light (if equipped)

Press this button to activate the light

7 Outrigger function enable button

Press this button to activate the individual outrigger up/down function.

8 Outrigger auto level button

Press this button to activate the auto level function.

9 Engine glow plug button

Press and hold this button to preheat engine.

10 LED readout screen

Diagnostic readout.

11 Engine start button

Press this button to start the engine.

12 Engine lower speed idle select button

Press this button to select the engine idle setting. Light on indicates lower idle is selected.

13 Lift function select button

Press this button to activate the lift function.

14 Proportional control handle

Lift function: Press and hold the function enable switch to enable the lift function on the platform control handle. Move the control handle in the direction indicated by the blue arrow and the platform will raise. Move the control handle in the direction indicated by the yellow arrow and the platform will lower. The descent alarm should sound while the platform is lowering.

Drive function: Press and hold the function enable switch to enable the drive function on the platform control handle. Move the control handle in the direction indicated by the blue arrow on the control panel and the machine will move in the direction that the blue arrow points. Move the control handle in the direction indicated by the yellow arrow on the control panel and the machine will move in the direction that the yellow arrow points.

Outrigger extendable / retractable function: Press and hold the function enable switch to enable the Outrigger extend/ retract function on the platform control handle. Move the control handle in the direction indicated by the yellow arrow and the outrigger will extend. Move the control handle in the direction indicated by the blue arrow and the outrigger will retract.

Control Panel

15 Thumb rocker switch

Press the thumb rocker switch in either direction to activate steer function.

16 Function enable switch

Press and hold the function enable switch to enable the drive/lift function.

Pre-operation Inspection



Do Not Operate Unless:

✓ You learn and practice the principles of safe machine operation contained in this operator's manual.

- 1 Avoid hazardous situations.
- 2 **Always perform a pre-operation inspection.**

Know and understand the pre-operation inspection before going on to the next section.

- 3 Inspect the workplace.
- 4 Always perform function tests prior to use.
- 5 Only use the machine as it was intended.

Fundamentals

It is the responsibility of the operator to perform a pre-operation inspection and routine maintenance.

The pre-operation inspection is a visual inspection performed by the operator prior to each work shift. The inspection is designed to discover if anything is apparently wrong with a machine before the operator performs the function tests.

The pre-operation inspection also serves to determine if routine maintenance procedures are required. Only routine maintenance items specified in this manual may be performed by the operator.

Refer to the list on the next page and check each of the items.

If damage or any unauthorized variation from factory delivered condition is discovered, the machine must be tagged and removed from service.

Repairs to the machine may only be made by a qualified service technician, according to the manufacturer's specifications. After repairs are completed, the operator must perform a pre-operation inspection again before going on to the function tests.

Scheduled maintenance inspections shall be performed by qualified service technicians, according to the manufacturer's specifications and the requirements listed in this manual.

Pre-operation Inspection

Pre-operation Inspection

- Be sure that the operator's, safety and responsibilities manuals are complete, legible and in the storage container located in the platform.
- Be sure that all decals are legible and in place. See Decals section.
- Check for engine oil leaks and proper oil level. Add oil if needed. See Maintenance section.
- Check for hydraulic oil leaks and proper oil level. Add oil if needed. See Maintenance section.
- Check for engine coolant leaks and proper level of coolant. Add coolant if needed. See Maintenance section.
- Check for battery fluid leaks and proper fluid level. Add distilled water if needed. See Maintenance section.

Check the following components or areas for damage, improperly installed or missing parts and unauthorized modifications:

- Electrical components, wiring and electrical cables
- Hydraulic hoses, fittings, cylinders and manifolds
- Fuel and hydraulic tanks
- Drive motors
- Wear pads
- Tires and wheels
- Engine and related components
- Limit switches, alarms and horn
- Nuts, bolts and other fasteners
- Platform overload components
- Platform entry gate
- Brake release components

Beacon (if equipped)

- Safety arm
- Platform extension(s)
- Scissor pins and retaining fasteners
- Platform control handle
- Generator (if equipped)
- Outrigger housings and footpads (if equipped)

Check entire machine for:

- Cracks in welds or structural components
- Dents or damage to machine
- Excessive rust, corrosion or oxidation
- Be sure that all structural and other critical components are present and all associated fasteners and pins are in place and properly tightened
- Be sure side rails are installed and bolts are fastened.

Note: If the platform must be raised to inspect the machine, make sure the safety arm is in place. See Operating Instructions section.

Workplace Inspection



Do Not Operate Unless:

You learn and practice the principles of safe machine operation contained in this operator's manual.

- 1 Avoid hazardous situations.
- 2 Always perform a pre-operation inspection.
- 3 Inspect the workplace.**

Know and understand the workplace inspection before going on to the next section.

- 4 Always perform function tests prior to use.
- 5 Only use the machine as it was intended.

Fundamentals

The workplace inspection helps the operator determine if the workplace is suitable for safe machine operation. It should be performed by the operator prior to moving the machine to the workplace.

It is the operator's responsibility to read and remember the workplace hazards, then watch for and avoid them while moving, setting up and operating the machine.

Workplace Inspection

Be aware of and avoid the following hazardous situations:

- Drop-offs or holes
- Bumps, floor obstructions or debris
- Sloped surfaces
- Unstable or slippery surfaces
- Overhead obstructions and high voltage conductors
- Hazardous locations
- Inadequate surface support to withstand all load forces imposed by the machine
- Wind and weather conditions
- The presence of unauthorized personnel
- Other possible unsafe conditions

Function Tests



Do Not Operate Unless:

You learn and practice the principles of safe machine operation contained in this operator's manual.

- 1 Avoid hazardous situations.
- 2 Always perform a pre-operation inspection.
- 3 Inspect the workplace.
- 4 **Always perform function tests prior to use.**

Know and understand the function tests before going on to the next section.

- 5 Only use the machine as it was intended.

Fundamentals

The function tests are designed to discover any malfunctions before the machine is put into service.

The operator must follow the step-by-step instructions to test all machine functions.

A malfunctioning machine must never be used. If malfunctions are discovered, the machine must be tagged and removed from service.

Repairs to the machine may only be made by a qualified service technician, according to the manufacturer's specifications.

After repairs are completed, the operator must perform a pre-operation inspection and function tests again before putting the machine into service.

Function Tests

At the Ground Controls

- 1 Select a test area that is firm, level and free of obstruction.
 - 2 Pull out main power switch to "on" position.
 - 3 Pull out the platform and ground red Emergency Stop button to the on position.
 - 4 Turn the key switch to ground control.
 - 5 Observe the display on the ground controls.
- ⊙ Result: The display readout will come on and display SYSTEM READY.
- 6 Start the engine. See Operating Instructions section.

Test Emergency Stop

- 7 Push in the ground red Emergency Stop button to the off position.
- ⊙ Result: The engine should turn off and no functions should operate.
- 8 Pull out the red Emergency Stop button to the on position. And restart the engine.

Test Up/Down Functions and Function Enable

A buzzer with different sound frequency is controlled in central system. The descent alarm sounds at 60 beeps per minute. The descent delay alarm sounds at 180 beeps per minute. The alarm that goes off when the machine is not level sounds at 180 beeps per minute. An optional automotive-style horn is also available.

- 9 Do not press the lift function enable button. Press and hold the platform up/down button.
- ⊙ Result: No function should operate.
- 10 Press and hold the lift function enable button. Press and hold the platform up button.

- ⊙ Result: The platform should rise.
- 11 Press and hold the lift function enable button. Press and hold the platform down button.

- ⊙ Result: The platform should lower the descent alarm should sound while the platform is lowering. The platform stop at the height is approximately 2.0 m from the ground. The descent delay alarm will sound.

Note: Be sure the area below the platform is clear of personnel and obstructions before continuing.

- 12 Press and hold the lift function enable button. Press and hold the platform down button.

- ⊙ Result: The platform should lower to end. The descent delay alarm should sound while the platform is lowering.

Test the Auxiliary Lowering

- 13 Activate the up function and raise the platform approximately 60 cm.
- 14 Pull the emergency lowering knob located the entry ladder end.

- ⊙ Result: The platform should lower. The descent alarm will not sound.

- 15 Restart the engine.

Test the Emergency Lowering

- 16 Activate the up function and raise the platform approximately 60 cm.
- 17 Push in the red Emergency Stop button to shut off the engine.
- 18 Pull out the red Emergency Stop button to the on position.
- 19 Press and hold the emergency lowering down enable button. Press and hold the emergency lowering down button.

Function Tests

⊙ Result: The platform should lower.

20 Turn the key switch to platform control and restart the engine.

At the Platform Controls

Test Emergency Stop

21 Push in the platform red Emergency Stop button to the off position.

⊙ Result: No functions should operate.

22 Pull the red Emergency Stop button out to the on position.

⊙ Result: The LED indicator light should come on.

Test the Horn

23 Push the horn button.

⊙ Result: The horn should sound.

Test Up/Down Functions and Function Enable

24 Start the engine.

25 Do not hold the function enable switch on the control handle.

26 Slowly move the control handle in the direction indicated by the blue arrow, then in the direction indicated by the yellow arrow.

⊙ Result: No functions should operate.

27 Press the lift function select button.

28 Press and hold the function enable switch on the control handle.

29 Slowly move the control handle in the direction indicated by the blue arrow.

⊙ Result: The platform should raise.

30 Release the control handle.

⊙ Result: The platform should stop raising.

31 Press and hold the function enable switch.

Slowly move the control handle in the direction indicated by the yellow arrow.

⊙ Result: The platform should lower. The descent alarm should sound while the platform is lowering.

Test the Steering

Note: When performing the steer and drive function test, stand in the platform facing the steer end of the machine.

32 Press the drive function select button. The indicator light should turn on.

33 Press and hold the function enable switch on the proportional control handle. Depress the thumb rocker switch on top of the proportional control handle in the direction identified by the blue triangle on the control panel.

⊙ Result: The steer wheels should turn in the direction that the blue triangle points on the control panel.

34 Press and hold the function enable switch on the proportional control handle. Depress the thumb rocker switch in the direction identified by the yellow triangle on the control panel.

⊙ Result: The steer wheels should turn in the direction that the yellow triangle points on the control panel.

Test Drive and Braking

35 Press and hold the function enable switch on the proportional control handle.

36 Slowly move the proportional control handle in the direction indicated by the blue arrow on the control panel until the machine begins to move, then return the proportional control handle to the center position.

⊙ Result: The machine should move in the

Function Tests

direction that the blue arrow points on the control panel, then come to an abrupt stop.

37 Press and hold the function enable switch on the proportional control handle.

38 Slowly move the proportional control handle in the direction indicated by the yellow arrow on the control panel until the machine begins to move, then return the proportional handle to the center position.

- ⊙ Result: The machine should move in the direction that the yellow arrow points on the control panel, then come to an abrupt stop.

Note: The brakes must be able to hold the machine on any slope it is able to climb.

Test Limited Drive Speed

39 Press the lift function select button. Raise the platform approximately 2.4 m from the ground.

40 Press the drive function select button.

41 Press and hold the function enable switch on the proportional control handle slowly move the proportional control handle to the full drive position.

- ⊙ Result: The maximum achievable drive speed with the platform raised should not exceed 12.5cm/s.
- ⊘ Result: If the drive speed with the platform raised exceeds 12.5cm/s, immediately tag and remove the machine from service.

Test the Tilt Sensor Operation

Note: Perform this test from the ground with the platform controller. Do not stand in the platform.

42 Fully lower the platform.

43 Drive both wheels on one side onto an 5cm block.

44 Raise the platform approximately 2.4 m from the ground.

- ⊙ Result: The platform should stop and the tilt alarm will sound at 180 beeps per minute.

The platform controls LED readout should display LL.

45 Press the drive function select button.

46 Press and hold the function enable switch on the control handle.

47 Move the proportional control handle in the direction indicated by the blue arrow, then move the proportional control handle in the direction indicated by the yellow arrow.

- ⊙ Result: The drive function should not work in either direction.

48 Press the lift function enable button.

49 Lower the platform and drive the machine off the block.

Test Auxiliary Lowering

50 Push the lift function select button and raise the platform approximately 60 cm.

51 Push in the red Emergency Stop button to shut off the engine.

52 Pull out the red Emergency Stop button to the on position.

53 Push the lift function select button.

54 Press and hold the function enable switch on the proportional control handle. Activate the proportional control handle in the direction indicated by the yellow arrow.

- ⊙ Result: The platform should lower.

Test the Outrigger System (if equipped)

55 Push and hold the auto level button.

56 Press and hold the function enable switch. Activate the proportional control handle in the direction indicated by the yellow arrow.

- ⊙ Result: The outriggers will extend and level the machine. A beep will sound when the

Function Tests

machine is level.

57 Push and hold the auto level button.

58 Press and hold the function enable switch. Activate the proportional control handle in the direction indicated by the blue arrow.

- ⦿ Result: The outriggers should retract and return to the stowed position. A beep will sound when the machine is in the stowed position.

Test the Oscillate System

Note: Perform this test from the ground with the platform controller. Do not stand in the platform.

59 Start the engine from the platform controls.

60 Select the engine idle button to indicate high idle. Light on indicates high idle.

Test the Oscillate System (stowed position)

61 Drive the left steer tire up onto a 10 cm high ramp.

- ⦿ Result: All four tires should maintain firm contact with the ground.

62 Drive the right steer tire up onto a 10 cm high ramp.

- ⦿ Result: All four tires should maintain firm contact with the ground.

Note: Verify that there are no fault codes shown on ground control display.

Test the Oscillate System (elevated position)

63 Press the lift function select button. Raise the platform approximately 2.4 m from the ground.

64 Drive the left steer tire into a 10 cm deep hole.

- ⦿ Result: All four tires should maintain firm contact with the ground.

65 Drive the right steer tire into a 10 cm deep

hole.

- ⦿ Result: All four tires should maintain firm contact with the ground.

Note: Verify that there are no fault codes shown on ground control display.

Operating Instructions



Do Not Operate Unless:

- You learn and practice the principles of safe machine operation contained in this operator's manual.
- 1 Avoid hazardous situations.
- 2 Always perform a pre-operation inspection.
- 3 Inspect the workplace.
- 4 Always perform function tests prior to use.
- 5 **Only use the machine as it was intended.**

Fundamentals

This machine is a self-propelled hydraulic lift equipped with a work platform on the scissor mechanism. Vibrations emitted by these machines are not hazardous to an operator in the work platform. The machine can be used to position personnel with their tools and supplies at position above ground level and can be used to reach work areas located above and over machinery or equipment.

A full and detailed implementation of EN ISO 13849-1/2 is correctly applied on our MEWP design. SISTEMA, a software tool for PL Calculation Tool, is also used to perform some relatively straightforward calculations on subsystem to determine the overall PL of the system. Reliability data, diagnostic coverage [DC], the system architecture [Category], common cause failure and, where relevant, requirements for software are used to assess the PL to comply with PLr of SRP/CS in Clause 5.11 of EN 280.

The Operating Instructions section provides instructions for each aspect of machine operation.

It is the operator's responsibility to follow all the safety rules and instructions in the operator's manual.

Using the machine for anything other than lifting personnel, along with their tools and materials, to an aerial work site is unsafe and dangerous.

Only trained and authorized personnel should be permitted to operate a machine. If more than one operator is expected to use a machine at different times in the same work shift, they must all be qualified operators and are all expected to follow all safety rules and instructions in the operator's manual. That means every new operator should perform a pre-operation inspection, function tests, and a workplace inspection before using the machine.

Operating Instructions

Emergency Stop

Push in the red Emergency Stop button to the off position at the ground controls or the platform controls to stop all machine functions and turn the engine off.

Repair any function that operates when either red Emergency Stop button is pushed in.

Emergency Lowering

- 1 Pull the emergency lowering knob.

Starting the Engine

- 1 At the ground controls, turn the key switch to the desired position.
- 2 Be sure both ground and platform control red Emergency Stop buttons are in the on position.
- 3 Press the glow plug button for 3 to 5 seconds.
- 4 Press the engine start button.

If the engine fails to start after 15 seconds of cranking, determine the cause and repair any malfunction. Wait 60 seconds before trying to start again.

In cold conditions, -6°C and below, warm the engine for 5 minutes before operating to prevent hydraulic system damage.

In extreme cold conditions, -18°C and below, machines should be equipped with optional cold start kits. Attempting to start the engine when temperatures are below -18°C may require the use of a booster battery.

Operation from Ground

- 1 Turn the key switch to ground control.
- 2 Pull out the platform and ground red Emergency Stop button to the on position.

- 3 Start the engine.

To Position Platform

- 1 Press the lift function enable button.
- 2 Press the platform up/down button to activate the up function or the down function.

Drive and steer functions are not available from the ground controls.

Engine Idle Select

Select the engine idle (rpm) by press.

Operation from Platform

- 1 Turn the key switch to platform control.
- 2 Pull out the platform and ground red Emergency Stop button to the on position.
- 3 Start the engine.

To Position Platform

- 1 Press the lift function select button.
- 2 Press and hold the function enable switch on the control handle.
- 3 Activate the proportional control handle in the desired direction.

To Steer

- 1 Press the drive function select button.
- 2 Press and hold the function enable switch on the control handle.
- 3 Turn the steer wheels with the thumb rocker switch located on the top of the control handle.

To Drive

- 1 Press the drive function select button.
- 2 Press and hold the function enable switch on the control handle.
- 3 Increase speed: Slowly move the control handle off center.

Operating Instructions

Decrease speed: Slowly move the control handle toward center.

Stop: Return the control handle to center or release the function enable switch.

Use the direction arrows on the platform controls to identify the direction the machine will travel.

Machine travel speed is restricted when the platform is raised.

Drive speed select

The drive controls can operate in two different drive speed modes. When the engine lower speed idle select button light is on, slow drive speed mode is active. When the engine high speed idle select button light is on, fast drive speed mode is active.

Driving on a slope

Determine the slope and side slope ratings for the machine and determine the slope grade.

Maximum slope rating, stowed position 40%.

Maximum side slope rating, stowed position 40%.

Note: Slope rating is subject to ground conditions and adequate traction.

To determine the slope grade

Measure the slope with a digital inclinometer or use the following procedure.

You will need:

Carpenter's level

Straight piece of wood, at least 1 m long
tape measure

Lay the piece of wood on the slope.

At the downhill end, lay the level on the top edge of the piece of wood and lift the end until the piece of wood is level.

While holding the piece of wood level, measure the distance from the bottom of the piece of wood to the ground.

Divide the tape measure distance (rise) by the length of the piece of wood (run) and multiply by 100.

Example:

Run = 3.6 m

Rise = 0.3 m

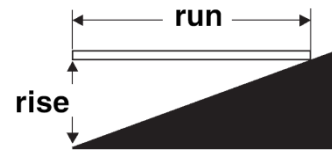

$$0.3 \text{ m} \div 3.6 \text{ m} = 0.083 \times 100 = 8.3\%$$

If the slope exceeds the maximum slope or side slope rating, the machine must be winched or transported up or down the slope. See Transport and Lifting section.

To Extend and Retract Platform

- 1 Lift the platform extension lock handle to the horizontal position.
- 2 Push the platform extension lock handle to extend the platform to the desired position.

Note: Do not stand on the platform extension while trying to extend it.

- 3 Lower the platform extension lock handle.

Outrigger Operation (if equipped)

- 1 Position the machine below the desired work area.

Note: The engine must be running for the outriggers to operate.

- 2 Push and hold the **outrigger** auto level button.
- 3 Press and hold the function enable switch. Activate the proportional control handle in the direction indicated by the yellow arrow. The outriggers will extend and level the machine. A beep will sound when the machine is level.

The indicator light on the lift function enable button will turn on when one but not all outriggers are down. All drive and lift functions

Operating Instructions

are disabled.

The indicator lights on the lift function enable button and on the individual outrigger buttons will turn off when all the outriggers are in firm contact with the ground.

The drive function is disabled while the outriggers are down.

To control individual outriggers

- 1 Push and hold one or more outrigger **function enable** buttons.
- 2 Press and hold the function enable switch. Activate the proportional control handle in the direction indicated by the yellow arrow. The outriggers will extend and level the machine.

⚠ WARNING Cannot use the outrigger directly on uneven surface, soft ground, pit edges and slopes greater ground, To avoid the risk of machine tipping, casualties and equipment damage. If it must be used on the above ground, be sure to use wood or steel pad adapt to the ground, and make sure it is firm.

How to use the Safety Arm

- 1 Raise the platform approximately 4 m from the ground.
- 2 Lift the safety arm, move it to the center of the scissor arm and rotate down to a vertical position.
- 3 Lower the platform until the safety arm rests securely on the link. Keep clear of the safety arm when lowering the platform.

⚠ DANGER Don't engage the safety arm unless unload the platform.

How to Fold Down the Guardrails

The platform railing system consists of three fold down rail section for the extension deck and three sections for the main deck. All sections are held in place by four latches.

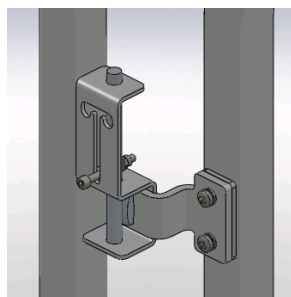

Closed latch

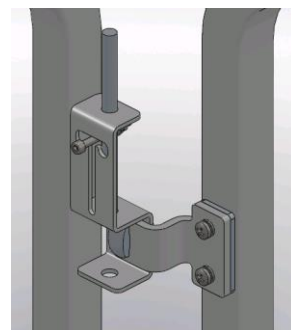

Open latch

- 1 Fully lower the platform and retract the platform extension.
- 2 Remove the platform controls.
- 3 Opening the latches in the corners the rails have to be folded in correct order of the numbering.

Operating Instructions

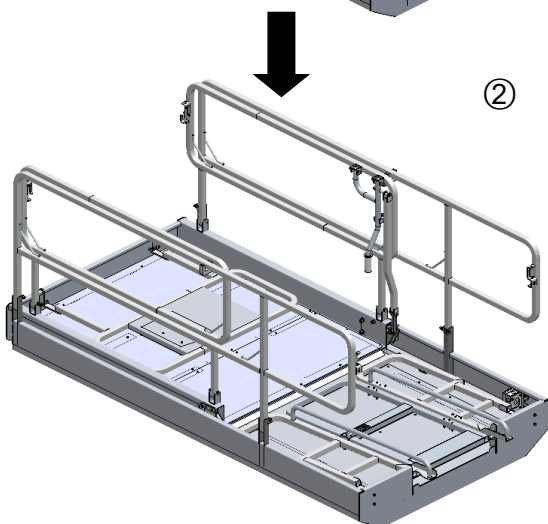
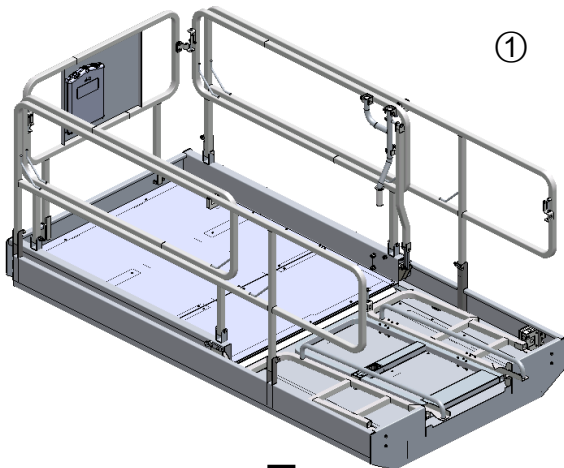
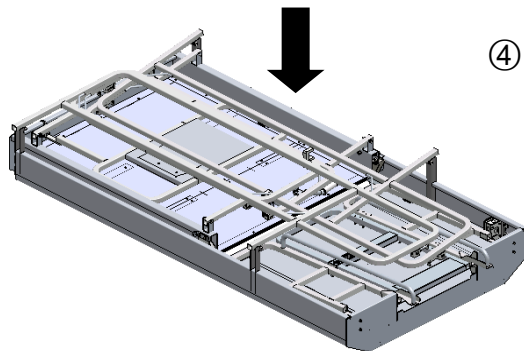
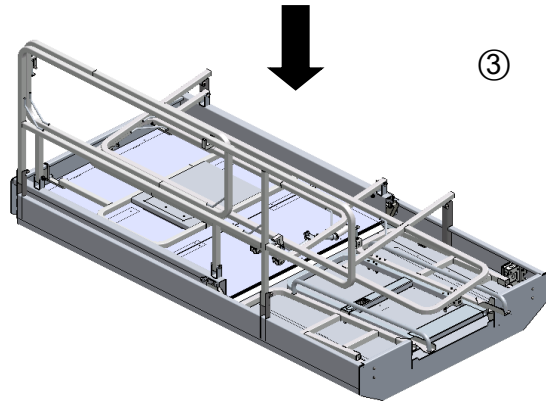
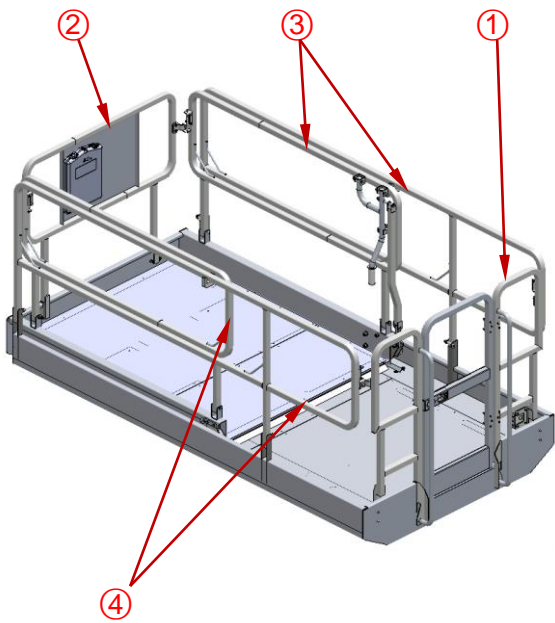

How to Raise the Guardrails

Follow the fold down instructions but in reverse order.

After Each Use

- 1 Select a safe parking location - firm level surface, clear of obstructions and traffic.
- 2 Lower the platform.
- 3 Turn the key switch to the off position and remove the key to secure from unauthorized use.
- 4 Push in the red Emergency Stop buttons to "off" position.
- 5 Push in the main power switch to "off" position.
- 6 Check the wheels.

Operating Instructions

Fault State

If the LED diagnostic readout displays an error code, such as LL, push in and **pull out** the red Emergency Stop button to reset the system.

List of Fault Codes

Display for Platform	Display for Ground	Description
01	01 Internal ECU Fault	Main ECU System Fault
02	02 Platform ECU Fault	ECU/Platform Communication Fault
14	14 Angle Sensor Fault	Angle Sensor Fault
15	15 Pressure Sensor Fault	Pressure Sensor Fault
20	20 Chassis Start Sw Fault	Chassis Start Switch ON at power-up
21	21 Chassis Choke Sw Fault	Chassis Choke Switch ON at power-up
22	22 Chassis Up Sw Fault	Chassis Up Switch ON at power-up
23	23 Chassis Lift Sw Fault	Chassis Lift Switch ON at power-up
24	24 Chassis Down Sw Fault	Chassis Down Switch ON at power-up
25	25 Left Turn switch Fault	Platform Left Turn Switch ON at power-up
26	26 Right Turn switch Fault	Platform Right Turn Switch ON at power-up
27	27 Drive Enable Sw Flt	Platform Drive Enable Switch ON at power-up
28	28 Off Neutral Drive Joystick	Platform Joystick not in neutral ON at power-up
31	31 Platform Choke Sw Fault	Platform Choke Switch ON at power-up
32	32 Platform Start Sw Fault	Platform Start Switch ON at power-up
33	33 Left Front outrig Sw Flt	Platform Left Front Outrigger Enable Switch ON at power-up
34	34 Right Front outrig Sw Flt	Platform Right Front Outrigger Enable Switch ON at power-up
35	35 Left Rear outrig Sw Flt	Platform Left Rear Outrigger Enable Switch ON at power-up
36	36 Right Rear outrig Sw Flt	Platform Right Rear Outrigger Enable Switch ON at power-up
37	37 Auto Level Switch Fault	Platform Outrigger Auto Level Enable Switch ON at power-up
38	38 LF OR Limit Switch Fault	Left Front Outrigger Limit Switches are both ON
39	39 RF OR Limit Switch Fault	Right Front Outrigger Limit Switches are both ON
40	40 LR OR Limit Switch Fault	Left Rear Outrigger Limit Switches are both ON
41	41 RR OR Limit Switch Fault	Right Rear Outrigger Limit Switches are both ON

Operating Instructions

Display for Platform	Display for Ground	Description
43	43 Folat limit switch fault	Folat limit t Switches are both ON
49	49 Drive Coil 1 Fault	Power FET, channel DRIVE 1 fails
50	50 Drive Coil 2 Fault	Power FET, channel DRIVE 2 fails
51	51 Drive Coil 3 Fault	Power FET, channel DRIVE 3 fails
52	52 Func Prop Coil Fault	power FET, channel PROPORTIONAL 1 fails
54	54 Up Coil Fault	Power FET, channel DOWN fails
55	55 Down Coil Fault	Power FET, channel RT fails
56	56 Right Turn Coil Fault	Power FET, channel LT fails
57	57 Left Turn Coil Fault	Power FET, channel LT fails
58	58 Brake Coil Fault	Power FET, channel LT fails
60	60 Forward 1 Coil Fault	Power FET, channel FORWARD LEFT fails
61	61 Reverse 1 Coil Fault	Power FET, channel REVERSE LEFT fails
66	66 Low Oil Pressure	Oil Pressure Fault
67	67 High Cool ant Temperature	Water Temperature Fault
68	68 Low ECU Voltage	Low Battery Voltage
69	69 Low Engine RPM	Low RPM Fault
70	70 High Engine RPM	High RPM Fault
81	81 Left Front Otrg Coil Flt	Power FET, channel LEFT FRONT OUTRIGGER fails
82	82 Left Rear Otrg Coil Flt	Power FET, channel LEFT REAR OUTRIGGER fails
83	83 Right Front Otrg Coil Flt	Power FET, channel RIGHT FRONT OUTRIGGER fails
84	84 Right Rear Otrg Coil Flt	Power FET, channel RIGHT REAR OUTRIGGER fails
85	85 Outrigger Ext Coil Fit	Power FET, channel EXTEND OUTRIGGER fails
86	86 Outrigger Ret Coil Fit	Power FET, channel RETRACT OUTRIGGER fails
95	95 Machine Type Fault	Wrong Machine Type Selected
OL	98 Platform Overload	Platform Overload Fault
LL		Machine Tilted Beyond Safe Limits Fault

For more information, please consult the appropriate Dingli Service Dept.

Transport and Lifting Instructions



Observe and Obey:

- ✓ Common sense and planning must be applied to control the movement of the machine when lifting it with a crane or forklift.
- ✓ Only qualified aerial lift operators should move the machine on or off the truck.
- ✓ The transport vehicle must be parked on a level surface.
- ✓ The transport vehicle must be secured to prevent rolling while the machine is being loaded.
- ✓ Be sure the vehicle capacity, loading surfaces and chains or straps are sufficient to withstand the machine weight. See the serial label for the machine weight.
- ✓ The machine must be on a level surface or secured before releasing the brakes.
- ✓ Do not allow the rails to fall when the snap pins are removed. Maintain a firm grasp on the rails when the rails are lowered.
- ✓ Do not drive the machine on a slope that exceeds the slope or side slope rating. See Driving on a Slope in the Operating Instructions section.
- ✓ If the slope of the transport vehicle bed exceeds the maximum slope rating, the machine must be loaded and unloaded using a winch as described.

Free-wheel Configuration for Winching

Chock the wheels to prevent the machine from rolling.

2WD models: Release the non-steer wheel brakes by turning over the torque hub disconnect caps and loosen the L valve of drive valve (see below).

4WD models: Release the wheel brakes by turning over all four torque hub disconnect caps and loosen the L valve of drive valve (see below).

Be sure the winch line is properly secured to the drive chassis tie points and the path is clear of all obstructions.

Reverse the procedures described to re-engage the brakes.

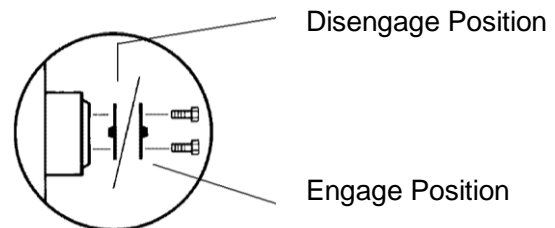

Transport and Lifting Instructions

Securing to Truck or Trailer for

Transit

Always chock the machine wheels in preparation for transport.

Retract and secure the extension deck(s).

Use the tie-down points on the chassis for anchoring down to the transport surface.

Use a minimum of four chains or straps.

Use chains or straps of ample load capacity.

Turn the key switch to the off position and remove the key before transporting.

Inspect the entire machine for loose or unsecured items.

If the railings have been folded down, secure them with straps before transporting.

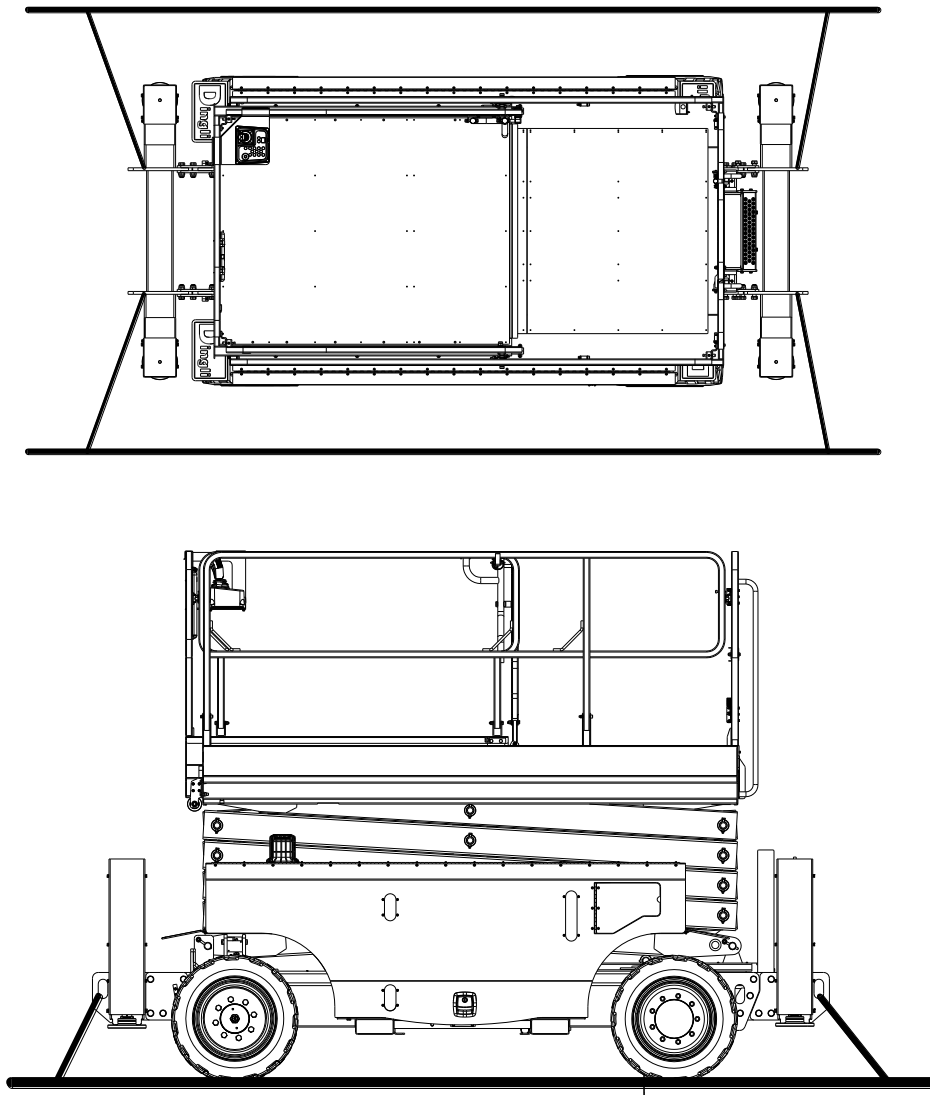

Transport and Lifting Instructions



Observe and Obey:

- Only qualified riggers should rig and lift the machine.
- Only qualified forklift operators should lift the machine with a forklift.
- Be sure the crane capacity, loading surfaces and straps or lines are sufficient to withstand the machine weight. See the serial plate for the machine weight.

Lifting Instructions

Fully lower the platform. Be sure the extension decks, controls and covers are secure. Remove all loose items on the machine.

Determine the center of gravity of your machine using the table and the picture on this page.

Attach the rigging only to the designated lifting points on the machine. There are two lifting points on each end of the machine.

Adjust the rigging to prevent damage to the machine and to keep the machine level.

Center of gravity	X Axis	Y Axis
JCPT1218RT	1.1m	0.78m
JCPT1418RT	1.1m	0.84m

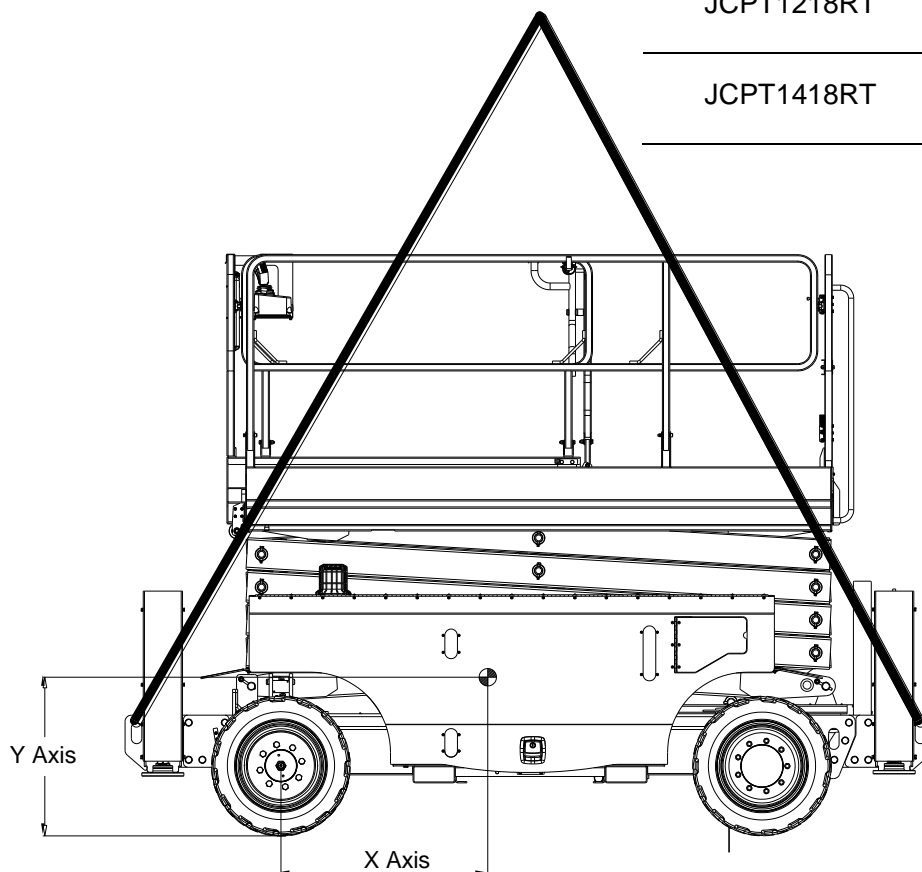

Maintenance



Observe and Obey:

- ✓ Only routine maintenance items specified in this manual shall be performed by the operator.
- ✓ Scheduled maintenance inspections shall be completed by qualified service technicians, according to the manufacturer's specifications and the requirements specified in this manual.

Maintenance Symbols Legend

NOTICE The following symbols have been used in this manual to help communicate the intent of the instructions. When one or more of the symbols appear at the beginning of a maintenance procedure, it conveys the meaning below.



Indicates that tools will be required to perform this procedure.



Indicates that new parts will be required to perform this procedure.



Indicates that a cold engine is required before performing this procedure.



Indicates that a warm engine will be required to perform this procedure.



Indicates that dealer service will be required to perform this procedure.

Pre-delivery Preparation Report

The pre-delivery preparation report contains checklists for each type of scheduled inspection.

Make copies of the Pre-delivery Preparation report to use for each inspection. Store completed forms as required.

Maintenance Schedule

There are five types of maintenance inspections that must be performed according to a schedule— daily, quarterly, semi-annually, annually, and two year. The Scheduled Maintenance Procedures Section and the Maintenance Inspection Report have been divided into five subsections—A, B, C, D, and E. Use the following chart to determine which group(s) of procedures are required to perform a scheduled inspection.

Inspection	Checklist
Daily or every 8 hours	A
Quarterly or every 250 hours	A+B
Semi-annually or every 500 hours	A+B+C
Annually or every 1000 hours	A+B+C+D
Two year or every 2000 hours	A+B+C+D+E

Maintenance Inspection Report

The maintenance inspection report contains checklists for each type of scheduled inspection.

Make copies of the Maintenance Inspection Report to use for each inspection. Maintain completed forms for a minimum of 4 years or in compliance with your employer, jobsite and governmental regulations and requirements.

Maintenance

Pre-delivery Preparation Report

Fundamentals

It is the responsibility of the dealer to perform the Pre-delivery Preparation.

The Pre-delivery Preparation is performed prior to each delivery. The inspection is designed to discover if anything is apparently wrong with a machine before it is put into service.

A damaged or modified machine must never be used. If damage or any variation from factory delivered condition is discovered, the machine must be tagged and removed from service.

Repairs to the machine may only be made by a qualified service technician, according to the manufacturer's specifications.

Scheduled maintenance inspections shall be performed by qualified service technicians, according to the manufacturer's specifications and the requirements listed in this manual.

Instructions

Use the operator's manual on your machine.

The Pre-delivery Preparation consists of completing the Pre-operation Inspection, the Maintenance items and the Function Tests.

Use this form to record the results. Place a check in the appropriate box after each part is completed. Follow the instructions in the operator's manual.

If any inspection receives an N, remove the machine from service, repair and re-inspect it. After repair, place a check in the R box.

Legend

Y = yes, completed

N = no, unable to complete

R = repaired

Comments

Pre-Delivery Preparation	Y	N	R
Pre-operation inspection completed			
Maintenance items completed			
Function tests completed			

Model

Serial number

Date

Machine owner

Inspected by (print)

Inspector signature

Inspector title

Inspector company

Maintenance

Maintenance Inspection Report

Model
Serial number
Date
Hour meter
Machine owner
Inspected by (print)
Inspector signature
Inspector title
Inspector company

Instructions

- Make copies of this report to use for each inspection.
- Select the appropriate checklist(s) for the type of inspection to be performed.

<input type="checkbox"/> Daily or 8 hours Inspection:	A
<input type="checkbox"/> Quarterly or 250 hours Inspection:	A+ B
<input type="checkbox"/> Semi-annually or 500 hours Inspection:	A+B+C
<input type="checkbox"/> Annually or 1000 hours Inspection:	A+B+C+D
<input type="checkbox"/> Two year or 2000 hours Inspection:	A+B+C+D+E

- Place a check in the appropriate box after each inspection procedure is completed.
- Use the step-by-step procedures in this section to learn how to perform these inspections.
- If any inspection receives an "N", tag and remove the machine from service, repair and re-inspect it. After repair, place a check in the "R" box.

Legend

- Y = yes, acceptable
- N = no, remove from service
- R = repaired

Checklist A	Y	N	R
A-1 manuals and decals			
A-2 Pre-operation inspection			
A-3 Check the Batteries			
A-4 Test the Oscillate System			
A-5 Check the Engine Oil Level			
A-6 Check the Hydraulic Oil Level			
A-7 Check the Engine Coolant Level			
A-8 Function tests			
A-9 Engine maintenance			
Perform after 40 hours:			
A-10 30 day service			
Perform every 50 hours:			
A-11 Engine maintenance			
Perform every 100 hours:			
A-12 Engine maintenance			
Perform every 200 hours:			
A-13 Engine maintenance			
Checklist B	Y	N	R
B-1 Battery			
B-2 Electrical wiring			
B-3 Tires and wheels			
B-4 Check the Oil Level in the Drive Hubs			

Maintenance

B-5 Emergency stop				E-2 Engine maintenance			
B-6 Key switch				E-3 Engine maintenance			
B-7 Horn (if equipped)							
B-8 Drive brakes							
B-9 Drive speed - stowed							
B-10 Drive speed - raised							
B-11 Hydraulic oil analysis							
B-12 Fuel and Hydraulic Tank Cap Venting System							
B-13 Test the down limit switches							
B-14 Test the up limit switches							
B-15 Test the Flashing Beacons							
Perform every 400 hours:							
B-16 Engine maintenance							
Checklist C	Y	N	R				
C-1 Platform overload (if equipped)							
C-2 Down Limit Switch Descent Delay							
C-3 Breather cap - models with optional oil							
C-4 Engine maintenance							
C-5 Engine maintenance							
Checklist D	Y	N	R				
D-1 Hydraulic filter							
D-2 Scissor arm wear pads							
D-3 Engine maintenance							
D-4 Engine maintenance							
D-5 Replace the Drive Hub Oil							
D-6 Engine maintenance							
Checklist E	Y	N	R				
E-1 Hydraulic oil							

Checklist A Procedures

A-1

Inspect the Manuals and Decals

Maintaining the operator's manual in good condition is essential to safe machine operation. Manuals are included with each machine and should be stored in the container provided in the platform. An illegible or missing manual will not provide safety and operational information necessary for a safe operating condition.

In addition, maintaining all of the safety and instructional decals in good condition is mandatory for safe machine operation. Decals alert operators and personnel to the many possible hazards associated with using this machine. They also provide users with operation and maintenance information. An illegible decal will fail to alert personnel of a procedure or hazard and could result in unsafe operating conditions.

- 1 Check to make sure that the operator's manual is present and complete in the storage container on the platform.
- 2 Examine the pages of manual to be sure that they are legible and in good condition.

☉ Result: The operator's manual is appropriate for the machine and the manual are legible and in good condition.

☒ Result: The operator's manual is not appropriate for the machine or the manual is not in good condition or is illegible. Remove the machine from service until the manual is replaced.

- 3 Open the operator's manual to the decals inspection section. Carefully and thoroughly inspect all decals on the machine for legibility and damage.

☉ Result: The machine is equipped with all required decals, and all decals are legible and in good condition.

☒ Result: The machine is not equipped with all required decals, or one or more decals are illegible or in poor condition. Remove the machine from service until the decals are replaced.

- 4 Always return the manual to the storage container after use.

Note: Contact your authorized DINGLI distributor or DINGLI Industries if replacement manuals or decals are needed.

Maintenance

A-2

Perform Pre-operation Inspection

Completing a Pre-operation Inspection is essential to safe machine operation. The Pre-operation Inspection is a visual inspection performed by the operator prior to each work shift. The inspection is designed to discover if anything is apparently wrong with a machine before the operator performs the function tests. The Pre-operation Inspection also serves to determine if routine maintenance procedures are required.

Complete information to perform this procedure is available in the appropriate operator's manual. Refer to the Operator's Manual on your machine.

A-3

Check the Battery



Proper battery condition is essential to good machine performance and operational safety. Improper fluid levels or damaged cables and connections can result in component damage and hazardous conditions.

⚠ WARNING Electrocution hazard. Contact with hot or live circuits may result in death or serious injury. Remove all rings, watches and other jewelry.

⚠ WARNING Bodily injury hazard. Battery contain acid. Avoid spilling or contacting battery acid. Neutralize battery acid spills with baking soda and water.

- 1 Put on protective clothing and eye wear.
- 2 Be sure that the battery cable connections are tight and free of corrosion.
- 3 Be sure that the battery hold-down bars are secure.
- 4 Remove the battery vent caps.
- 5 Check the battery acid level. If needed, replenish with distilled water to the bottom of the battery fill tube. Do not overfill.
- 6 Install the vent caps.

A-4**Test the Oscillate System**

The oscillate system is designed so that all four tires maintain firm contact with the ground on unlevel terrain, improving traction and machine stability.

Proper axle oscillation is essential to safe machine operation. If the axle oscillation system is not operating correctly, the stability of the machine is compromised and it may tip over.

Test the Oscillate System (stowed position)

- 1 Drive the left steer tire up onto a 10 cm high ramp.
- ⊙ Result: All four tires should maintain firm contact with the ground.
- 2 Drive the right steer tire up onto a 10 cm high ramp.
- ⊙ Result: All four tires should maintain firm contact with the ground.

Note: Verify that there are no fault codes shown on ground control display.

Test the Oscillate System (elevated position)

- 3 Press the lift function select button. Raise the platform approximately 2.4 m from the ground.
- 4 Drive the left steer tire into a 10 cm deep hole.
- ⊙ Result: All four tires should maintain firm contact with the ground.
- 5 Drive the right steer tire into a 10 cm deep hole.
- ⊙ Result: All four tires should maintain firm contact with the ground.

Note: Verify that there are no fault codes shown on ground control display.

A-5**Check the Engine Oil Level**

Maintaining the proper engine oil level is essential to good engine performance and service life.

Operating the machine with an improper oil level can damage engine components.

NOTICE

Check the oil level with the engine off.

- 1 Open the engine cover
- 2 Release the latches on the engine tray and fully rotate out
- 3 Check the oil level dipstick. Add oil as needed.

Oil type	5W-30
Oil type – cold conditions	0W-20

Maintenance

A-6

Check the Hydraulic Oil Level



Maintaining the hydraulic oil at the proper level is essential to machine operation. Improper hydraulic oil levels can damage hydraulic components. Daily checks allow the inspector to identify changes in oil level that might indicate the presence of hydraulic system problems.

NOTICE

Perform this procedure with the platform in the stowed position and the engine off.

- 1 Visually inspect the sight of hydraulic oil level from the side of the hydraulic oil tank.
- ⊕ Result: The hydraulic oil level should be within the top 5 cm of the tank.
- 2 Add oil if necessary. Do not overfill.

NOTICE

Original Hydraulic oil specifications: L-HV46

Customers shall choose the appropriate hydraulic oil according to the ambient temperature used.

Example: L-HV32 or L-HV68

A-7

Check the Engine Coolant Level



Maintaining the engine coolant at the proper level is essential to engine service life. Improper coolant level will affect the engine's cooling capability and damage engine components. Daily checks will allow the inspector to identify changes in coolant level that might indicate cooling system problems.

Check the fluid level in the radiator. Add fluid as needed.

WARNING

Bodily injury hazard. Fluids in the radiator are under pressure and extremely hot. Use caution when removing cap and adding fluids.

A-8

Perform Function Tests

Completing the function tests is essential to safe machine operation. Function tests are designed to discover any malfunctions before the machine is put into service. A malfunctioning machine must never be used. If malfunctions are discovered, the machine must be tagged and removed from service.

Complete information to perform this procedure is available in the appropriate operator's manual. Refer to the Operator's Manual on your machine.

Maintenance

A-9

Perform Engine Maintenance



Engine specifications require that this procedure be performed every 8 hours or daily, whichever comes first.

Required maintenance procedures and additional engine information is available in the engine operator's manual.

A-11

Perform Engine Maintenance



Engine specifications require that this procedure be performed every 50 hours

Required maintenance procedures and additional engine information is available in the engine operator's manual.

A-10

Perform 30 Day Service



The 30 day maintenance procedure is a one time procedure to be performed after the first 30 days or 40 hours of usage. After this interval, refer to the maintenance tables for continued scheduled maintenance.

- 1 Perform the following maintenance procedures:
 - B-3 Inspect the Tires, Wheels and Castle Nut Torque
 - B-4 Check the Oil Level in the Drive Hubs
 - D-2 Replace the Hydraulic Tank Return Filter Element

A-12

Perform Engine Maintenance



Engine specifications require that this procedure be performed every 100 hours

Required maintenance procedures and additional engine information is available in the engine operator's manual.

A-13

Perform Engine Maintenance



Engine specifications require that this procedure be performed every 200 hours

Required maintenance procedures and additional engine information is available in the engine operator's manual.

Maintenance

Checklist B Procedures

B-1

Inspect the Battery



DINGLI requires that this procedure be performed every 250 hours or quarterly, whichever comes first.

Proper battery condition is essential to good machine performance and operational safety. Improper fluid levels or damaged cables and connections can result in component damage and hazardous conditions.

⚠ WARNING Electrocuting / burn hazard. Contact with electrically charged circuits could result in death or serious injury. Remove all rings, watches and other jewelry.

⚠ WARNING Bodily injury hazard. Battery contain acid. Avoid spilling or contacting battery acid. Neutralize battery acid spills with baking soda and water.

- 1 Put on protective clothing and eye wear.
- 2 Be sure that the battery cable connections are free of corrosion.

Note: Adding terminal protectors and a corrosion preventative sealant will help eliminate corrosion on the battery terminals and cables.

- 3 Be sure that the battery retainers and cable connections are tight.
- 4 Fully charge the battery. Allow the battery to rest 24 hours before performing this procedure to allow the battery cells to equalize.
- 5 Remove the battery vent caps and check the specific gravity of each battery cell with a hydrometer. Note the results.

- 6 Check the ambient air temperature and adjust the specific gravity reading for each cell as follows:
 - Add 0.004 to the reading of each cell for every 5.5° C above 26.7° C.
 - Subtract 0.004 from the reading of each cell for every 5.5° C below 26.7° C.
- ⊙ Result: All battery cells display an adjusted specific gravity of 1.277 or higher. The battery is fully charged. Proceed to step 10.
- ⊖ Result: One or more battery cells display a specific gravity of 1.217 or below. Proceed to step 7.
- 7 Perform an equalizing charge OR fully charge the battery and allow the battery to rest at least 6 hours.
- 8 Remove the battery vent caps and check the specific gravity of each battery cell with a hydrometer. Note the results.
- 9 Check the ambient air temperature and adjust the specific gravity reading for each cell as follows:
 - Add 0.004 to the reading of each cell for every 5.5° C above 26.7° C.
 - Subtract 0.004 from the reading of each cell for every 5.5° C below 26.7° C.
- ⊙ Result: All battery cells display a specific gravity of 1.277 or greater. The battery is fully charged. Proceed to step 10.
- ⊖ Result: One or more battery cells display a specific gravity from 1.269 to 1.218. The battery is still usable, but at a lower performance so will need to be recharged

Maintenance

more often. Proceed to step 11.

- ☐ Result: One or more battery cells display a specific gravity from 1.217 to 1.173. The battery is approaching the end of its life. Proceed to step 11.
 - ☐ Result: The difference in specific gravity readings between cells is greater than 0.1 OR the specific gravity of one or more cells is less than 1.172 or less. Replace the battery.
- 10 Check the battery acid level. If needed, replenish with distilled water to 3 mm below the bottom of the battery fill tube. Do not overfill.
 - 11 Install the vent caps and neutralize any electrolyte that may have spilled.

B-2**Inspect the Electrical Wiring**

DINGLI requires that this procedure be performed every 250 hours or quarterly, whichever comes first.

Maintaining electrical wiring in good condition is essential to safe operation and good machine performance. Failure to find and replace burnt, chafed, corroded or pinched wires could result in unsafe operating conditions and may cause component damage.

⚠ WARNING Electrocutation / burn hazard. Contact with electrically charged circuits could result in death or serious injury. Remove all rings, watches and other jewelry.

- 1 Inspect the following areas for burnt, chafed, corroded and loose wires:
 - Ground control panel
 - Hydraulic tray
 - Engine tray
 - Scissor arms
 - Platform controls
- 2 Inspect for a liberal coating of dielectric grease in the following locations:
 - Between the ECM and platform controls
 - All wire harness connectors
 - Level sensor
- 3 **Turn the key switch to ground control. Pull out the platform and ground red Emergency Stop button to the on position**
- 4 Start the engine and raise the platform approximately 3.0 m from the ground.
- 5 Lift the safety arm, move it to the center of the scissor arm and rotate up to a vertical

Maintenance

position.

- 6 Lower the platform onto the safety arm.

⚠ WARNING Crushing hazard. Keep hands clear of the safety arm when lowering the platform.

- 7 Inspect the center chassis area and scissor arms for burnt, chafed and pinched cables.
- 8 Inspect the following areas for burnt, chafed, corroded, pinched and loose wires:
 - ECU to platform controls
 - Power to platform wiring
- 9 Raise the platform and return the safety arm to the stowed position.
- 10 Lower the platform to the stowed position and turn the machine off.

B-3

Inspect the Tires and Wheels (including castle nut torque)



DINGLI requires that this procedure be performed every 250 hours or quarterly, whichever comes first.

Maintaining the tires and wheels in good condition is essential to safe operation and good performance. Tire and/or wheel failure could result in a machine tip-over. Component damage may also result if problems are not discovered and repaired in a timely fashion.

- 1 Check the tire surface and sidewalls for cuts, cracks, punctures and unusual wear.
- 2 Check each wheel for damage, bends and cracks.
- 3 Remove the castle nut lock plate or cotter pin and check each nut for proper torque

Castle nut torque, dry	406.7Nm
------------------------	---------

Castle nut torque, lubricated	305Nm
-------------------------------	-------

Note: Always replace the cotter pin with a new one when removing the castle nut or checking the torque of the castle nut.

- 4 Check each lug bolt for proper torque.
- 5 Install the castle nut lock plate using a new lock washer OR install a new cotter pin and secure.

Maintenance**B-4****Check the Oil Level in the Drive Hubs**

Dingli requires that this procedure be performed every 250 hours or quarterly, whichever comes

Failure to maintain proper drive hub oil levels may cause the machine to perform poorly and continued use may cause component damage.

- 1 Drive the machine to rotate the hub until the plugs are located one on top and the other at 90 degrees.

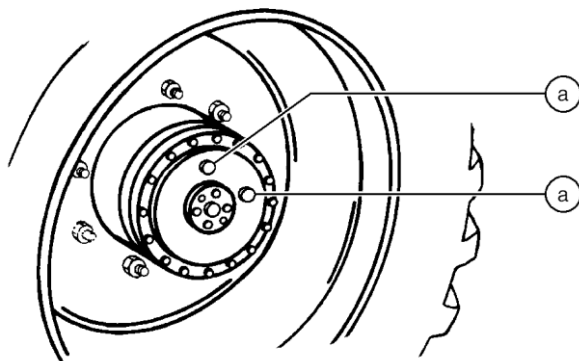

a drive hub plugs

- 2 Remove the plug located at 90 degrees and check the oil level.
 - ⊙ Result: The oil level should be even with the bottom of the side plug hole.
- 3 If necessary, remove the top plug and add oil until the oil level is even with the bottom of the side plug hole.
- 4 Apply pipe thread sealant to the plug(s), and then install the plug(s) in the drive hub.
- 5 Repeat this procedure for each drive hub.

NOTICE

Original oil specifications:

80W-90

B-5**Test the Emergency Stop**

DINGLI requires that this procedure be performed every 250 hours or quarterly, whichever comes first.

A properly functioning Emergency Stop is essential for safe machine operation. An improperly operating red Emergency Stop button will fail to shut off power and stop all machine functions, resulting in a hazardous situation.

As a safety feature, selecting and operating the ground controls will override the platform controls, except the platform red Emergency Stop button.

- 1 Start the engine from ground controls.
- 2 Push in the red Emergency Stop button at the ground controls to the off position.
 - ⊙ Result: The engine should shut off and no machine functions should operate.
- 3 Start the engine from platform controls.
- 4 Push in the red Emergency Stop button to the off position..
 - ⊙ Result: The engine should shut off and no machine functions should operate.

Note: The red Emergency Stop button at the ground controls will stop all machine operation, even if the key switch is switched to platform control.

Maintenance

B-6

Test the Key Switch

DINGLI requires that this procedure be performed every 250 hours or quarterly, whichever comes first.

Proper key switch action and response is essential to safe machine operation. The machine can be operated from the ground or platform controls and the activation of one or the other is accomplished with the key switch. Failure of the key switch to activate the appropriate control panel could cause a hazardous operating situation.

Perform this procedure from the ground using the platform controls. Do not stand in the platform.

- 1 Pull out the platform and ground red Emergency Stop button to the on position.
- 2 Turn the key switch to ground controls and start the engine from ground controls.
- 3 Check any machine function from the platform controls.
⊙ Result: The machine functions should not operate.
- 4 Turn the key switch to platform controls and start the engine from platform controls.
- 5 Check the machine functions from the ground controls.
⊙ Result: The machine functions should not operate.
- 6 Turn the key switch to the off position.
⊙ Result: Result: The engine should stop and no functions should operate.

B-7

Test the Automotive-style Horn

DINGLI requires that this procedure be performed every 250 hours or quarterly, whichever comes first.

The horn is activated at the platform controls and sounds at the ground as a warning to ground personnel. An improperly functioning horn will prevent the operator from alerting ground personnel of hazards or unsafe conditions.

- 1 Start the engine from platform controls.
- 2 Push down the horn button at the platform controls.
⊙ Result: The horn should sound.

Note: If necessary, the horn can be adjusted to obtain the loudest volume by turning the adjustment screw near the wire terminals on the horn.

B-8**Test the Drive Brakes**

DINGLI requires that this procedure be performed every 250 hours or quarterly, whichever comes first.

Proper brake action is essential to safe machine operation. The drive brake function should operate smoothly, free of hesitation, jerking and unusual noise.

Hydraulically-released individual wheel brakes can appear to operate normally when not fully operational.

Perform this procedure with the machine on a firm level surface that is free of obstructions, with the platform extension deck fully retracted and the platform in the stowed position.

- 1 Mark a test line on the ground for reference.
 - 2 Start the engine from platform controls.
 - 3 Choose a point on the machine; i.e., contact patch of a tire, as a visual reference for use when crossing the test line.
 - 4 Slowly move the joystick in the direction indicated by the blue arrow on the control panel until the machine begins to move, then return the joystick to the center position.
- ⊙ Result: The machine should move in the direction that the blue arrow points on the control panel, then come to an abrupt stop.
- 5 Slowly move the joystick in the direction indicated by the yellow arrow on the control panel until the machine begins to move, then return the joystick to the center position.

- ⊙ Result: The machine should move in the direction that the yellow arrow points on the control panel, then come to an abrupt stop.
- 6 Bring the machine to maximum drive speed before reaching the start line. Release the function enable switch on the joystick or release the joystick when your reference point on the machine crosses the test line.
 - 7 Measure the distance between the test line and your machine reference point.
 - 8 Replace the brakes and repeat this procedure beginning with step 1.

Braking distance, maximum

High range on paved surface	<150cm
-----------------------------	--------

Note: The brakes must be able to hold the machine on any slope it is able to climb.

Maintenance

B-9

Test the Drive Speed - Stowed Position



DINGLI requires that this procedure be performed every 250 hours or quarterly, whichever comes first.

Proper drive functions are essential to safe machine operation. The drive function should respond quickly and smoothly to operator control. Drive performance should also be free of hesitation, jerking and unusual noise over the entire proportionally controlled speed range.

Perform this procedure with the machine on a firm, level surface that is free of obstructions.

- 1 Create start and finish lines by marking two lines on the ground 12.2 m apart.
- 2 Turn the key switch to platform control. Pull out the platform and ground red Emergency Stop button to the on position.
- 3 Start the engine from the platform controls.
- 4 Lower the platform to the stowed position.
- 5 Choose a point on the machine; i.e., contact patch of a tire, as a visual reference for use when crossing the start and finish lines.
- 6 Bring the machine to maximum reverse drive speed before reaching the start line. Begin timing when your reference point on the machine crosses the start line.
- 7 Continue at full speed and note the time when your reference point on the machine passes over the finish line. The time is less than 8.8 sec.

B-10

Test the Drive Speed - Raised Position



DINGLI requires that this procedure be performed every 250 hours or quarterly, whichever comes first.

Proper drive functions are essential to safe machine operation. The drive function should respond quickly and smoothly to operator control. Drive performance should also be free of hesitation, jerking and unusual noise over the entire proportionally controlled speed range.

Perform this procedure with the machine on a firm, level surface that is free of obstructions.

- 1 Create start and finish lines by marking two lines on the ground 12.2 m apart.
- 2 Turn the key switch to platform control. Pull out the platform and ground red Emergency Stop button to the on position.
- 3 Start the engine from the platform controls.
- 4 Raise the platform approximately 2.4 m from the ground.
- 5 Choose a point on the machine; i.e., contact patch of a tire, as a visual reference for use when crossing the start and finish lines.
- 6 Bring the machine to top drive speed before reaching the start line. Begin timing when your reference point on the machine crosses the start line.
- 7 Continue at full speed and note the time when your reference point on the machine passes over the finish line. The time is less than 98 sec.

B-11**Perform Hydraulic Oil Analysis**

DINGLI requires that this procedure be performed every 250 hours or quarterly, whichever comes first.

Replacement or testing of the hydraulic oil is essential for good machine performance and service life. Dirty oil may cause the machine to perform poorly and continued use may cause component damage. Extremely dirty conditions may require oil changes to be performed more often.

Before replacing the hydraulic oil, the oil may be tested by an oil distributor for specific levels of contamination to verify that changing the oil is necessary.

If the hydraulic oil is not replaced at the two year inspection, test the oil quarterly. Replace the oil when it fails the test. See E-1, Test or Replace the Hydraulic Oil.

B-12**Inspect the Fuel and Hydraulic Tank Cap Venting System**

DINGLI requires that this procedure be performed quarterly or every 250 hours, whichever comes first. Perform this procedure more often if dusty conditions exist.

A free-breathing hydraulic tank cap is essential for good machine performance and service life. A dirty or clogged cap may cause the machine to perform poorly. Extremely dirty conditions may require that the cap be inspected more often.

⚠ DANGER Explosion and fire hazard.

Engine fuels are combustible. Perform this procedure in an open, well-ventilated area away from heaters, sparks, flames and lighted tobacco. Always have an approved fire extinguisher within easy reach

- 1 Remove the breather cap from the **fuel** tank.
- 2 Check for proper venting.
- ☉ Result: Air passes through the breather cap. Proceed to step 4.
- ☐ Result: If air does not pass through the cap, clean or replace the cap. Proceed to step 3.

Note: When checking for positive tank cap venting, air should pass freely through the cap only in one direction from the tank.

- 3 Using a mild solvent, carefully wash the cap venting system. Dry using low pressure compressed air. Repeat this procedure beginning with step 2.
- 4 Install the fuel tank cap onto the fuel tank.
- 5 Remove the breather cap from the hydraulic tank.

Maintenance

- 6 Check for proper venting.
 - ⊙ Result: Air passes through the fuel tank cap. Proceed to step 8..
 - ⊗ Result: If air does not pass through the cap, clean or replace the cap. Proceed to step 7.
- Note: When checking for positive tank cap venting, air should pass freely through the cap.
- 7 Using a mild solvent, carefully wash the cap venting system. Dry using low pressure compressed air. Repeat this procedure beginning with step 6.
 - 8 Install the breather cap onto the hydraulic tank.

B-13

Test the Down Limit Switch



DINGLI requires that this procedure be performed every 250 hours or quarterly, whichever comes first.

Maintaining the limit switches is essential to safe operation and good machine performance. Operating the machine with a faulty limit switch could result in reduced machine performance and a potentially unsafe operating condition.

Perform these procedures with the machine on a firm, level surface that is free of obstructions.

- 1 Remove the platform controls from the platform.
- 2 Start the engine from the platform controls
- 3 Press the engine high speed idle select button.
 - ⊙ Result: The light will turn on. The machine is functioning properly.
 - ⊗ Result: The light will turn off, replace the down limit switch.
- 4 Press the Lift function select button.
- 5 Raise the platform 4 m.
- 6 Lift the safety arm, move it to the center of the scissor arm and rotate up to a vertical position.
- 7 Lower the platform until the safety arm rests securely on the link. Keep clear of the safety arm when lowering the platform.

⚠ WARNING Crushing hazard. Keep hands clear of the safety arm when lowering the platform.

- 8 Press the roller arm of the limit switch. Activate the switch contacts.

Maintenance

- ⊙ Result the engine high speed idle select button light will turn off when press the drive speed button. The machine is functioning properly.
- ⊖ Result the engine high speed idle select button light will turn on when press the drive speed button. The machine is functioning properly.
- 9 Raise the platform and return the safety arm to the stowed position.
- 10 Lower the platform to the stowed position.

B-14**Test the Up Limit Switch**

DINGLI requires that this procedure be performed every 250 hours or quarterly, whichever comes first.

Maintaining the limit switches is essential to safe operation and good machine performance.

Operating the machine with a faulty limit switch could result in reduced machine performance and a potentially unsafe operating condition.

Perform these procedures with the machine on a firm, level surface that is free of obstructions.

- 1 Start the engine from the ground controls.
- 2 Raise the platform approximately 4m from the ground controls.
- 3 Lift the safety arm, move it to the center of the scissor arm and rotate up to a vertical position.
- 4 Lower the platform until the safety arm rests securely on the link. Keep clear of the safety arm when lowering the platform.

⚠ WARNING Crushing hazard. Keep hands clear of the safety arm when lowering the platform.

- 5 While raising the platform from the ground controls, push in the roller of the up limit switch to activate the limit switch.

- ⊙ Result: The platform stops rising. The machine is functioning properly.
- ⊖ Result: The platform continues to rise. Adjust or replace the up limit switch.
- 6 Raise the platform and rotate the safety arm to the home position.
- 7 Lower the platform to the stowed position.

Maintenance

B-15

Test the Flashing Beacons

DINGLI requires that this procedure be performed every 250 hours or quarterly, whichever comes first.

Flashing beacons are used to alert operators and ground personnel of machine proximity and motion. The flashing beacons are located on both sides of the machine.

- 1 Pull out the platform and ground red Emergency Stop button to the on position.
- 2 Turn the key switch to ground controls and start the engine from ground controls.

⊙ Result: The beacons should flash.

- 3 Turn the key switch to platform controls and start the engine from platform controls.

⊙ Result: The beacons should flash.

B-16

Perform Engine Maintenance



Engine specifications require that this procedure be performed every 400 hours

Required maintenance procedures and additional engine information is available in the engine operator's manual.

Checklist C Procedures

C-1

Test the Platform Overload System (if equipped)



DINGLI requires that this procedure be performed every 500 hours or six months, whichever comes first OR when the machine fails to lift the maximum rated load.

Testing the platform overload system regularly is essential to safe machine operation.

Continued use of an improperly operating platform overload system could result in the system not sensing an overloaded platform condition. Machine stability could be compromised resulting in the machine tipping over.

⚠ WARNING Perform this procedure with the machine on a firm, level surface.

Note: Perform this test from the ground with the platform controller. Do not stand in the platform.

1 Pull out the platform and ground red Emergency Stop button to the on position.

2 Turn the key switch to platform controls and start the engine from platform controls.

3 Determine the maximum platform capacity.

4 Using a suitable lifting device, place an appropriate test weight equal to the maximum platform capacity in the center of the platform floor.

Result: The overload alarm at the platform controls should not sound, indicating a normal condition.

Result: The overload alarm at the platform controls sounds. Calibrate the platform overload system.

5 Add an additional weight to the platform not to exceed 30% of the maximum rated load.

Result: The overload alarm at the platform controls sound, indicating a normal condition.

Result: The overload alarm at the platform controls does not sound. Calibrate the platform overload system.

6 Test all machine functions from the platform controls.

Result: All platform control functions should operate.

7 Turn the key switch to ground controls and start the engine from ground controls.

8 Test all machine functions from the ground controls

Result: All ground control functions should not operate.

9 Lift the test weight off the platform floor using a suitable lifting device.

Result: The overload alarm at the platform controls should not sound, indicating a normal condition.

Result: The overload alarm at the platform controls sounds. Calibrate the platform overload system.

10 Test all machine functions from the ground controls.

Result: All ground control functions should operate.

Maintenance

- 11 Turn the key switch to platform controls and start the engine from platform controls.
- 12 Test all machine functions from the platform controls.
- Result: All platform control functions should operate.

C-2

Down Limit Switch Descent Delay (if equipped)

- 1 Turn the key switch to platform controls. Start the engine.
 - 2 Raise the platform approximately 3 m.
 - 3 Lower the platform until the down limit switch activates and the platform stops lowering. Quickly release the controls and then immediately attempt to lower the platform to the stowed position.
- ⊙ Result: The platform stops for 4 to 6 seconds. Release the joystick and proceed to step 4.
 - ⊘ Result: The platform does not stop.
- 4 Lower the platform to the stowed position.
 - 5 Push in the red Emergency Stop button to the off position.

Check the Down Limit Switch

Height

- 1 Turn the key switch to platform controls. Start the engine.
- 2 Raise the platform approximately 3 m.
- 3 Lower the platform until the down limit switch activates and the platform stops lowering.
- 4 Push in the red Emergency Stop button to the off position.
- 5 Measure the distance between the working surface and the platform deck.

JCPT1218RT	1.8 to 2.0m
JCPT1418RT	2.0 to 2.2m

Maintenance

C-3

Replace the Hydraulic Tank Breather Cap



DINGLI requires that this procedure be performed every 500 hours or semi-annually, whichever comes first.

The hydraulic tank is a vented-type tank. The breather cap has an internal air filter that can become clogged or, over time, can deteriorate. If the breather cap is faulty or improperly installed, impurities can enter the hydraulic system which may cause component damage. Extremely dirty conditions may require that the cap be inspected more often.

- 1 Remove and discard the hydraulic tank breather cap.
- 2 Install a new cap onto the tank.

C-4

Perform Engine Maintenance



Engine specifications require that this procedure be performed every 500 hours

Required maintenance procedures and additional engine information is available in the engine operator's manual.

C-5

Perform Engine Maintenance



Engine specifications require that this procedure be performed every 800 hours

Required maintenance procedures and additional engine information is available in the engine operator's manual.

Maintenance

Checklist D Procedures

D-1

Check the Scissor Arm Wear Pads and Slider Blocks



DINGLI requires that this procedure be performed every 1000 hours or annually, whichever comes first.

Maintaining the condition of the scissor arm wear pads is essential to safe machine operation. Continued use of worn out wear pads may result in component damage and unsafe operating conditions.

- 1 Measure the thickness of each platform scissor arm slider blocks at the non-steer end of the machine.
 - ⊙ Result: The measurement is 106 mm or more. Proceed to step 2.
 - ⊗ Result: The measurement is less than 106 mm. Replace both wear pads.
- 2 Measure the thickness of each chassis scissor arm upper and lower slider wear pads at the non-steer end of the machine.
 - ⊙ Result: The measurement is 8 mm or more.
 - ⊗ Result: The measurement is less than 8 mm. Replace both wear pads.

D-2

Replace the Hydraulic Tank Return Filter Element



DINGLI requires that this procedure be performed every 1000 hours or annually, whichever comes first.

Replacement of the hydraulic tank return filter is essential for good machine performance and service life. A dirty or clogged filter may cause the machine to perform poorly and continued use may cause component damage. Extremely dirty conditions may require that the filter be replaced more often.

CAUTION Bodily injury hazard. Beware of hot oil. Contact with hot oil may cause severe burns.

- 1 Remove the filter with an oil filter wrench. Clean the area where the hydraulic oil filter meets the filter head.

WARNING Bodily injury hazard.

Spraying hydraulic oil can penetrate and burn skin. Loosen hydraulic connections very slowly to allow the oil pressure to dissipate gradually. Do not allow oil to squirt or spray.

Note: The hydraulic filter is mounted on the hydraulic tank.

- 2 Apply a thin layer of fresh oil to the new oil filter gasket.
- 3 Install the new filter and tighten it securely by hand.
- 4 Use a permanent ink marker to write the date and number of hours from the hour meter on the filter..
- 5 Clean up any oil that may have spilled during the replacement procedure.

Maintenance

- 6 Pull out the platform and ground red Emergency Stop button to the on position.
Start the engine.
- 7 Raise the platform approximately 1 m.
- 8 Inspect the filter and related components to be sure that there are no leaks.

D-3

Perform Engine Maintenance



Engine specifications require that this procedure be performed annually.

Required maintenance procedures and additional engine information is available in the engine operator's manual.

D-4

Perform Engine Maintenance



Engine specifications require that this procedure be performed every 1000 hours.

Required maintenance procedures and additional engine information is available in the engine operator's manual.

Maintenance

D-5

Replace the Drive Hub Oil



Note: Dingli specifications require that this procedure be performed every 1000 hours or annually, whichever comes first.

Replacing the drive hub oil is essential for good machine performance and service life. Failure to replace the drive hub oil at yearly intervals may cause the machine to perform poorly and continued use may cause component damage.

- 1 Select the drive hub to be serviced. Drive the machine until one of the two plugs is at the lowest point.
- 2 Remove both plugs and drain the oil into a suitable container.
- 3 Drive the machine until one of the two plugs is at the highest point.

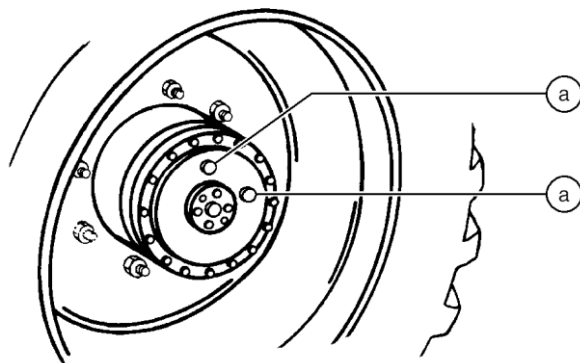

a drive hub plugs

- 4 Fill the hub until the oil level is even with the bottom of the lowest plug hole.
- 5 Install the plugs into the drive hub.
- 6 Repeat this procedure for each drive hub.

D-6

Perform Engine Maintenance



Engine specifications require that this procedure be performed every 1500 hours.

Required maintenance procedures and additional engine information is available in the engine operator's manual.

Checklist E Procedure

E-1

Test or Replace the Hydraulic Oil



DINGLI requires that this procedure be performed every 2000 hours or every two years, whichever comes first.

Replacement or testing of the hydraulic oil is essential for good machine performance and service life. Dirty oil and suction strainers may cause the machine to perform poorly and continued use may cause component damage. Extremely dirty conditions may require oil changes to be performed more often.

Note: Before replacing the hydraulic oil, the oil may be tested by an oil distributor for specific levels of contamination to verify that changing the oil is necessary. If the hydraulic oil is not replaced at the two year inspection, test the oil quarterly. Replace the oil when it fails the test.

Note: When removing a hose assembly or fitting, the O-ring (if equipped) on the fitting and/or the hose end must be replaced. All connections must be torqued to specification during installation.

- 1 Push in the red Emergency Stop button to the off position.
 - 2 Tag and disconnect the harnesses from the ground control box.
 - 3 Remove the ground control box retaining fasteners and set aside. Remove the ground control box.
 - 4 Locate the tank cover plate. Remove the tank cover plate mounting fasteners and remove the cover.
 - 5 Place a drain pan or other suitable container under the hydraulic tank.
 - 6 Remove the drain plug from the hydraulic tank and completely drain the tank.
- ⚠ WARNING** Bodily injury hazard.
Spraying hydraulic oil can penetrate and burn skin. Loosen hydraulic connections very slowly to allow the oil pressure to dissipate gradually. Do not allow oil to squirt or spray.
- 7 Tag, disconnect and plug the suction hose from the hydraulic tank. Cap the fitting.
 - 8 Tag, disconnect and plug the return hose at the return filter. Cap the fitting on the filter.
 - 9 Remove the return filter and head assembly from the tank. Cap and plug the fittings.
 - 10 Loosen the tank strap retaining fastener in front of the tank. Move the strap to the side.
 - 11 Remove the hydraulic tank from the machine.
 - 12 Remove the suction strainer and clean using a mild solvent or replace..
 - 13 Clean the inside of the hydraulic tank using a mild solvent..
 - 14 Install the drain plug using thread sealer on the threads.
 - 15 Install the suction strainer using thread sealer on the threads.
 - 16 Install the hydraulic tank onto the machine.
 - 17 Secure the tank with the tank strap. Do not over tighten.

Maintenance

- 18 Install the suction hose onto the tank.
- 19 Install the return filter and head assembly.

Note: Replace the return filter if needed.

- 20 Install the return hose to the return filter.
- 21 Fill the tank with hydraulic oil until the fluid is within the top 5 cm of the sight gauge. Do not overfill.
- 22 Clean up any oil that may have spilled. Properly discard the oil.
- 23 Operate all machine functions through a full cycle and check for leaks.
- 24 Check the oil level in the tank and add if needed.
- 25 Install the tank cover plate and install the tank cover plate mounting fasteners.

E-2

Perform Engine Maintenance



DINGLI requires that this procedure be performed every 2000 hours or every two years, whichever comes first.

Required maintenance procedures and additional engine information is available in the engine operator's manual.

E-3

Perform Engine Maintenance



DINGLI requires that this procedure be performed every 3000 hours.

Required maintenance procedures and additional engine information is available in the engine operator's manual.

Hydraulic Schematic-JCPT1218RT

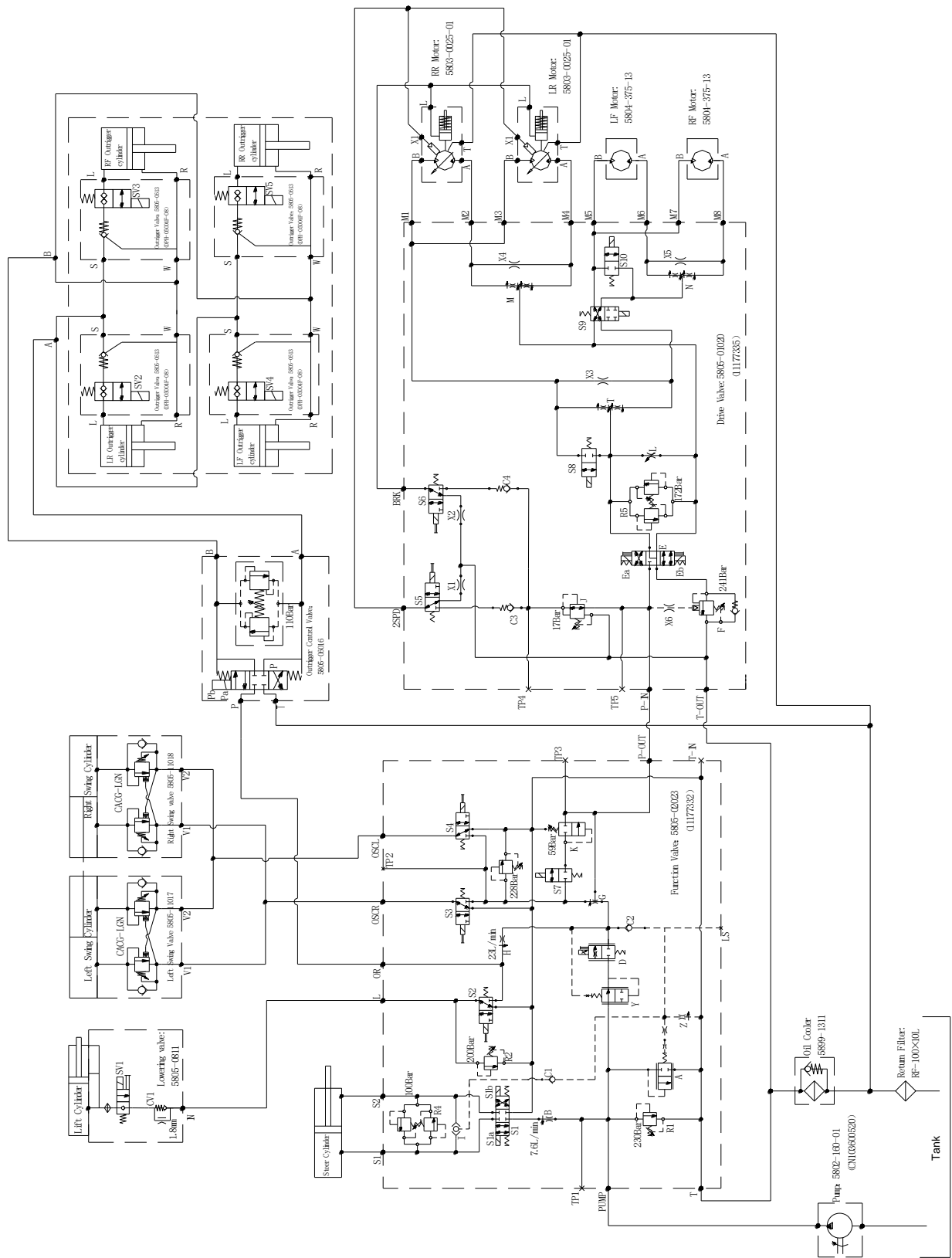

Electrical Schematic

