

A photograph of a construction site. In the foreground, four workers wearing hard hats and work clothes are standing on a muddy ground. One worker in the center is wearing a bright yellow high-visibility jacket. In the middle ground, a blue metal container sits on a wooden pallet. The background shows a large concrete structure under construction, with a body of water visible behind it. A large, stylized red and white graphic element is on the right side of the page.

GRINDEX PUMP HANDBOOK

50Hz







Welcome to Grindex Pump handbook!

With this handbook we want to share some of our wide experience in pumping with submersible pumps. You will find an overview of all Grindex pumps with technical details and a pump school, intended to help pump users with common matters in pumping with submersible pumps. The handbook also contains more sophisticated technical information, like pH tables and graphs that show friction losses in pipes and hoses.

We are sure you will find this handbook handy. This handbook is also available for download from our website, www.grindex.com.

If you need more copies, please contact a Grindex representative near you.

INDEX

	Drainage pumps	4-23
	Micro, Milli, Mini, Minex, Minette, Minor, Major, Master, Matador, Maxi, Magnum & Mega	
	Sludge pumps	24-31
	Solid, Salvador, Senior & Sandy	
	Drainage pumps made of stainless steel, INOX	32-39
	Minette Inox, Major Inox, Master Inox & Mega Inox	
	Sludge pumps made of stainless steel, INOX	40-45
	Salvador Inox, Senior Inox & Sandy Inox	
	Slurry pumps	46-57
	Bravo 200, 300, 400, 500, 600, 700, 800 & 900	
	Primo pumps	58-63
	Primo D4, D8, S4 & S8	
	Accessories	64-65
	Grindex Pump School	66-71
	Limitations	72
	More technical information	73-76
	Calculating friction losses in hoses	73
	Formulas for calculating friction losses in hoses and tubes	74
	Friction factor	74
	Sludge/slurry solids concentration	74
	pH tables	75
	Salt tables	75
	Translation charts	76
	Recommended generator sizes	77-78
	Torque values	79

Drainage pumps

Grindex drainage pumps are designed for professional use in tough applications like mines, construction sites, tunnel sites and other demanding industries.

They are designed for:

- Pumping water that may contain solids
– up to the size of the strainer holes
- Pumping water with abrasive solids
- Pumping ground water
- Pumping raw water
- Pumping spillage water

Grindex drainage pumps are designed for continuous, unattended operation. They have proven their reliability and dependable performance in demanding areas like building and construction, mining, tunnelling, quarries, industries and rental applications.



This page is a "target image" for the Grindex-app with 3D and Augmented Reality functions

FEATURES

Drainage Pumps

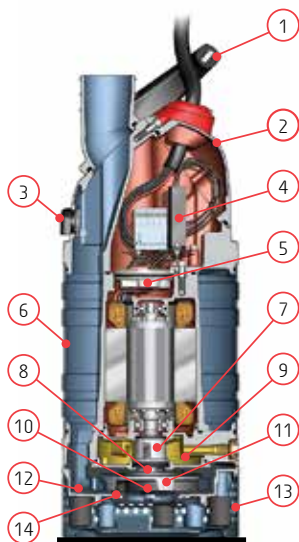

1. Ergonomic handle with a rubber grip on a metal frame
2. Inspection cover with large opening for easy access to junction box
3. Air valve cools the pump when no water is pumped
4. SMART motor protection including phase-failure guard, temperature guard and phase-sequence control eliminating the need for external start box
5. Enhanced terminal board with quick release terminal plate and sealing function
6. Durable outer jacket made from corrugated stainless steel
7. Easy service cartridge seal in rugged metal housing for improved heat transfer and longer pump life
8. Built-in particle repeller carries particles away from the seal for increased pump life
9. Simplified oil inspection and service, thanks to external plugs
10. Single adjustment screw for easy adjustment of the impeller and better performance
11. Hard-Iron™ impeller for maximum durability and performance
12. Heavy-duty polyurethane coating (optional for drainage pumps)
13. Durable strainer in stainless steel with ergonomic grip
14. Wear Protection system for increased life of hydraulic parts

MICRO

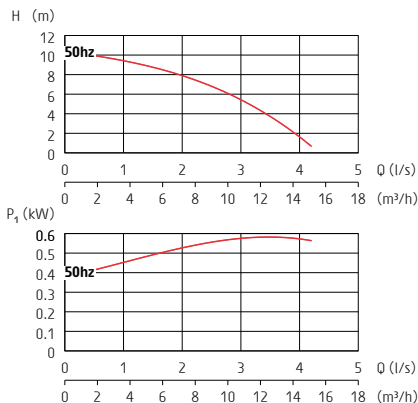

Technical Data 50 Hz

Micro

Pump type	8121.211
Discharge connection	2"
Rated power P2	420 W
Max. power cons. P1	590 W
Shaft speed	2760 RPM
Rated current at 115V	5.1 A
Rated current at 230V	2.7 A
Solids passage	11 x 5 mm
Max. height	440 mm
Max. width	185 mm
Weight	12 kg

For further information, see data sheets. Specifications can be changed without notice.

MILLI

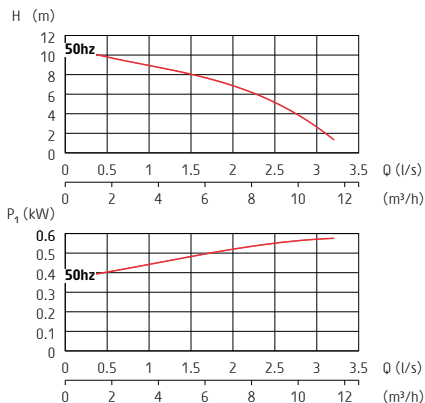

Technical Data 50 Hz

Milli

Pump type	8125.230
Discharge connection	2"
Rated power P2	420 W
Max. power cons. P1	590 W
Shaft speed	2760 RPM
Rated current at 115V	5.1 A
Rated current at 230V	2.7 A
Solids passage	6.2 mm
Max. height	464 mm
Max. width	188 mm
Weight	13 kg

For further information, see data sheets. Specifications can be changed without notice.

MINI

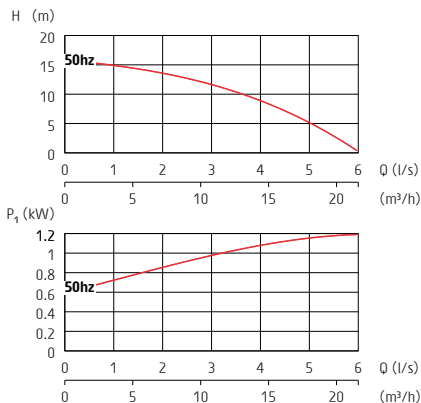

Technical Data 50 Hz

Mini

Pump type	8122.211
Discharge connection	2"
Rated power P ₂	900 W
Max. power cons. P ₁	1200 W
Shaft speed	2800 RPM
Rated current at 115V	11 A
Rated current at 230V	5.2 A
Solids passage	11 x 5 mm
Max. height	440 mm
Max. width	185 mm
Weight	14.5 kg

For further information, see data sheets. Specifications can be changed without notice.

MINEX LITE

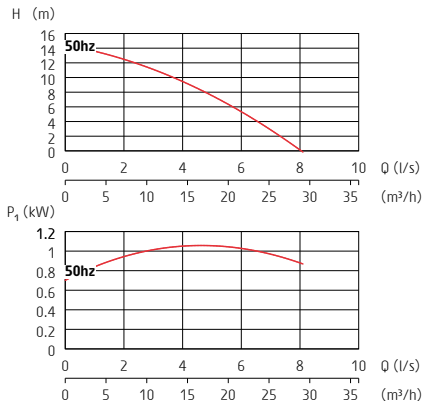

Technical Data 50 Hz

Minex Lite (1 ph)

Pump type	8101.172
Discharge connection	2"
Rated power P ₂	0.85 kW
Max. power cons. P ₁	1.1 kW
Shaft speed	2755 RPM
Rated current at 115V	11 A
Rated current at 230V	5.1 A
Solids passage	7.5 mm
Max. height	616 mm
Max. width	200 mm
Weight	21.5 kg

For further information, see data sheets. Specifications can be changed without notice.

MINEX

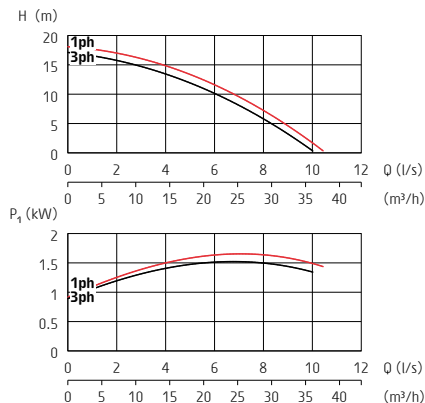

Technical Data 50 Hz	Minex 1 ph	Minex 3 ph
Pump type	8101.160	8101.172
Discharge connection	2"	2"
Rated power P ₂	1.4 kW	1.2 kW
Max. power cons. P ₁	1.8 kW	1.6 kW
Shaft speed	2870 RPM	2740 RPM
Rated current at 230V	7.8 A	4.7 A
Rated current at 400V	-	2.6 A
Rated current at 500V	-	-
Solids passage	7.5 mm	7.5 mm
Max. height	646 mm	616 mm
Max. width	200 mm	200 mm
Weight	25 kg	21.5 kg

For further information, see data sheets. Specifications can be changed without notice.

MINETTE

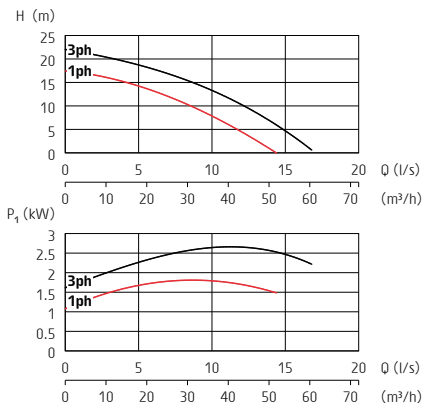

Technical Data 50 Hz

Minette 1 ph

Minette 3 ph

Technical Data 50 Hz	Minette 1 ph	Minette 3 ph
Pump type	8102.172	8102.172
Discharge connection	3"	3"
Rated power P ₂	1.5 kW	2.2 kW
Max. power cons. P ₁	1.9 kW	2.7 kW
Shaft speed	2830 RPM	2800 RPM
Rated current at 230V	8.4 A	8.1 A
Rated current at 400V	-	4.5 A
Rated current at 500V	-	3.6 A
Solids passage	9 mm	9 mm
Max. height	676 mm	676 mm
Max. width	240 mm	240 mm
Weight	29 kg	29 kg

For further information, see data sheets. Specifications can be changed without notice.

MINOR

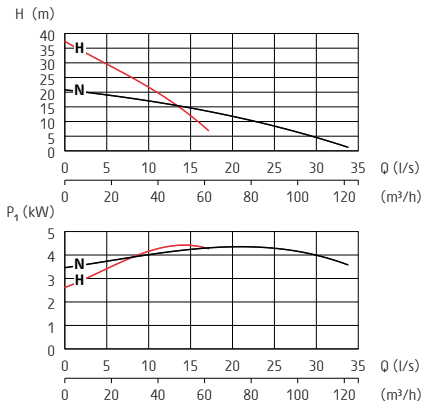

Technical Data 50 Hz	Minor N	Minor H
Pump type	8103.181	8103.181
Discharge connection	4"	3"
Rated power P2	3.7 kW	3.7 kW
Max. power cons. P1	4.4 kW	4.4 kW
Shaft speed	2885 RPM	2885 RPM
Rated current at 230V	13 A	13 A
Rated current at 400V	7.3 A	7.3 A
Rated current at 500V	5.9 A	5.9 A
Rated current at 1000V	2.9 A	2.9 A
Solids passage	10 mm	10 mm
Max. height	768 mm	768 mm
Max. width	286 mm	286 mm
Weight	48 kg	48 kg

For further information, see data sheets. Specifications can be changed without notice.

MAJOR

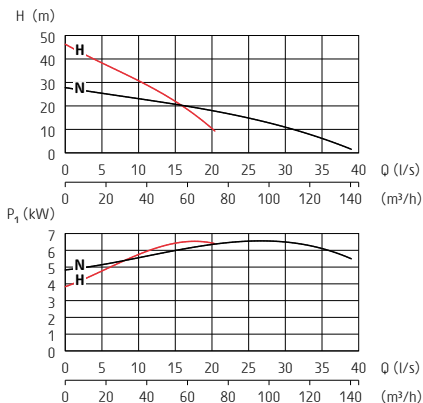
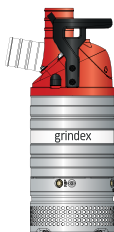

Technical Data 50 Hz

Major N

Major H

Pump type	8104.181	8104.181
Discharge connection	4"	3"
Rated power P ₂	5.6 kW	5.6 kW
Max. power cons. P ₁	6.6 kW	6.6 kW
Shaft speed	2895 RPM	2895 RPM
Rated current at 230V	19 A	19 A
Rated current at 400V	11 A	11 A
Rated current at 500V	8.7 A	8.7 A
Rated current at 1000V	4.3 A	4.3 A
Solids passage	10 mm	10 mm
Max. height	768 mm	768 mm
Max. width	286 mm	286 mm
Weight	50 kg	50 kg

For further information, see data sheets. Specifications can be changed without notice.

MASTER

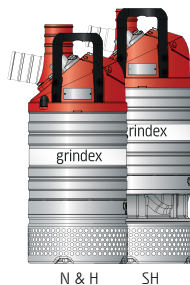
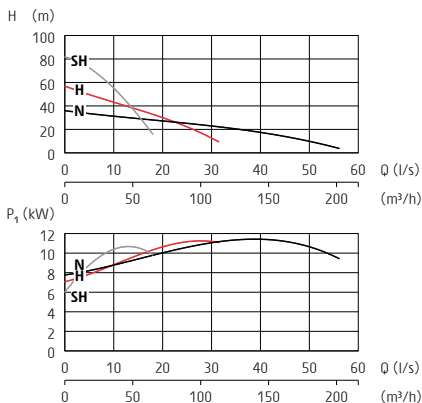

Technical Data 50 Hz	Master N	Master H	Master SH
Pump type	8105.182	8105.182	8105.182
Discharge connection	6"	4"	3"
Rated power P ₂	10 kW	10 kW	10 kW
Max. power cons. P ₁	11.7 kW	11.7 kW	11.7 kW
Shaft speed	2855 RPM	2855 RPM	2855 RPM
Rated current at 230V	33 A	33 A	33 A
Rated current at 400V	19 A	19 A	19 A
Rated current at 500V	15 A	15 A	15 A
Rated current at 1000V	8 A	8 A	8 A
Solids passage	10 mm	10 mm	10 mm
Max. height	832 mm	832 mm	887 mm
Max. width	346 mm	346 mm	346 mm
Weight	80 kg	80 kg	98 kg

For further information, see data sheets. Specifications can be changed without notice.

MATADOR

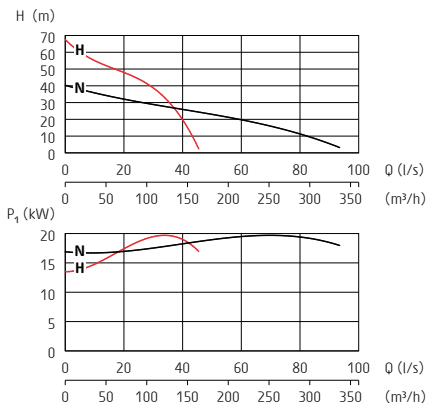

Technical Data 50 Hz

Matador N

Matador H

Pump type	8106.181	8106.181
Discharge connection	6"	4"
Rated power P ₂	18 kW	18 kW
Max. power cons. P ₁	20 kW	20 kW
Shaft speed	2905 RPM	2905 RPM
Rated current at 230V	56 A	56 A
Rated current at 400V	33 A	33 A
Rated current at 500V	26 A	26 A
Rated current at 1000V	14 A	14 A
Solids passage	12 mm	12 mm
Max. height	954 mm	954 mm
Max. width	395 mm	395 mm
Weight	131 kg	131 kg

For further information, see data sheets. Specifications can be changed without notice.

MAXI H LITE

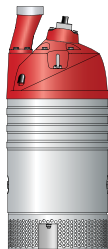
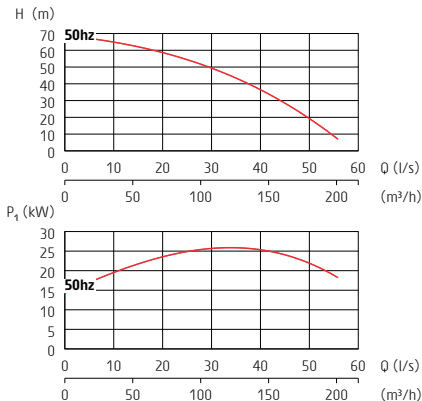

Technical Data 50 Hz

Maxi H Lite

Pump type	8107.300
Discharge connection	4"
Rated power P ₂	25 kW
Max. power cons. P ₁	28 kW
Shaft speed	2915 RPM
Rated current at 230V	76 A
Rated current at 400V	44 A
Rated current at 500V	35 A
Rated current at 1000V	18 A
Solids passage	12 mm
Max. height	1046 mm
Max. width	436 mm
Weight	210 kg

For further information, see data sheets. Specifications can be changed without notice.

MAXI N, H & L

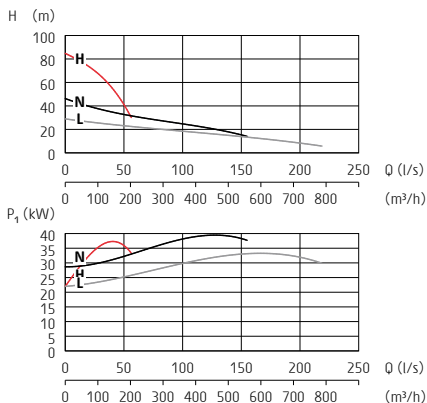
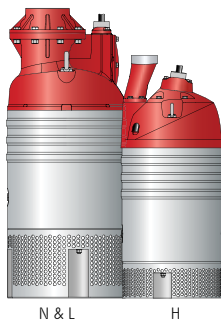

Technical Data 50 Hz	Maxi N	Maxi H	Maxi L
Pump type	8107.011	8107.011	8107.030
Discharge connection	8"	4"	8"
Rated power P ₂	37 kW	37 kW	30 kW
Max. power cons. P ₁	41 kW	41 kW	33 kW
Shaft speed	2950 RPM	2950 RPM	1465 RPM
Rated current at 230V	112 A	112 A	98 A
Rated current at 400V	65 A	65 A	57 A
Rated current at 500V	52 A	52 A	45 A
Rated current at 1000V	26 A	26 A	-
Solids passage	15 mm	12 mm	15 mm
Max. height	1302 mm	1046 mm	1302 mm
Max. width	506 mm	436 mm	506 mm
Weight	280 kg	240 kg	285 kg

For further information, see data sheets. Specifications can be changed without notice.

MAXI SH

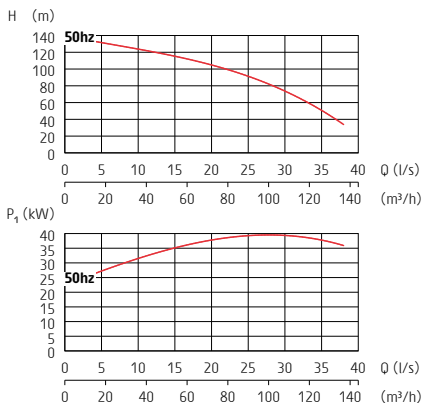

Technical Data 50 Hz

Maxi SH

Pump type	8107.011
Discharge connection	4"
Rated power P ₂	37 kW
Max. power cons. P ₁	41 kW
Shaft speed	2945 RPM
Rated current at 230V	112 A
Rated current at 400V	65 A
Rated current at 500V	51 A
Rated current at 1000V	26 A
Solids passage	12 mm
Max. height	1148 mm
Max. width	440 mm
Weight	270 kg

For further information, see data sheets. Specifications can be changed without notice.

MAGNUM

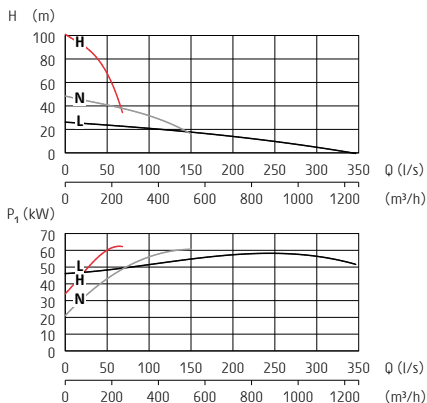
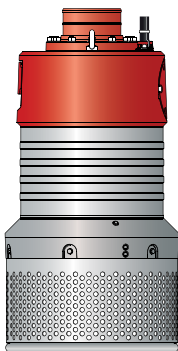

Technical Data 50 Hz	Magnum N	Magnum H	Magnum L
Pump type	8108.010	8108.010	8108.010
Discharge connection	8"	6"	10"
Rated power P ₂	57 kW	57 kW	57 kW
Max. power cons. P ₁	62 kW	64 kW	62 kW
Shaft speed	1475 RPM	2950 RPM	1475 RPM
Rated current at 230V	-	-	-
Rated current at 400V	107 A	99 A	107 A
Rated current at 500V	85 A	79 A	85 A
Rated current at 1000V	-	-	-
Solids passage	12 mm	12 mm	12 mm
Max. height	1475 mm	1475 mm	1475 mm
Max. width	750 mm	750 mm	750 mm
Weight	540 kg	540 kg	540 kg

For further information, see data sheets. Specifications can be changed without notice.

MEGA

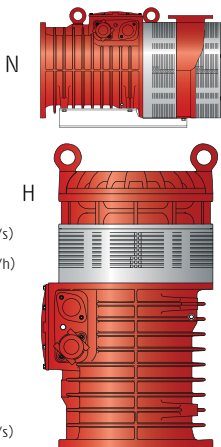
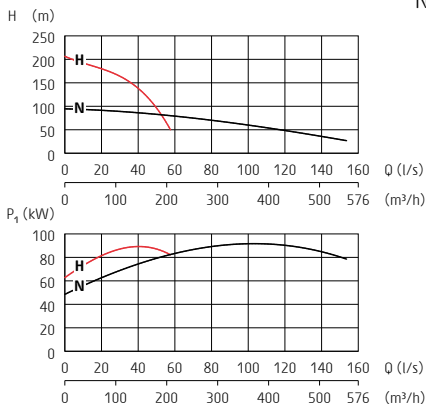

Technical Data 50 Hz

	Mega N	Mega H
Pump type	8124.400	8124.400
Discharge connection	6" (DN150)	4" (DN100)
Rated power P2	90 kW	90 kW
Max. power cons. P1	95 kW	95 kW
Shaft speed	2965 RPM	2965 RPM
Rated current at 400V	148 A	148 A
Rated current at 500V	117 A	117 A
Rated current at 1000V	60 A	60 A
Solids passage	10 mm	10 mm
Max. height	770 mm	1250 mm
Diameter	620 mm	620 mm
Max. width	1180 mm	700 mm
Weight	900 kg	985 kg

For further information, see data sheets. Specifications can be changed without notice.

Materials in drainage pumps

	Micro	Milli	Mini	Minex	Minette	Minor	Major	Master	Matador	Maxi	Magnum	Mega
Material												
Inner seal												
Tungsten carbide - Tungsten carbide									•	•	•	•
Tungsten carbide - Aluminium oxide				•	•	•	•	•				
Carbon - Aluminium oxide	•	•	•									
Outer seal												
Tungsten carbide - Tungsten carbide										•	•	•
Silicon carbide - Silicon carbide	•	•	•	•	•	•	•	•	•			
Casted parts												
Aluminium	•	•	•	•	•	•	•	•	•	•	•	
Cast iron												•
Stator housing												
Aluminium	•	•	•	•	•	•	•	•	•	•	•	
Cast iron												•
Outer casing												
Stainless steel				•	•	•	•	•	•	•	•	
Aluminium	•	•	•									
Cast iron												•

For further information, see data sheets. Specifications can be changed without notice.

	Micro	Milli	Mini	Minex	Minette	Minor	Major	Master	Matador	Maxi	Magnum	Mega	
Material													
Motor shaft													
Stainless steel	•	•	•	•	•	•	•	•	•	•	•	•	
Impeller													
Hard-Iron™				•	•	•	•	•	•	•	•	•	
Polyurethane	•	•	•										
Suction cover													
Hard-Iron™					3~	•	•	•	•				
Lower diffuser													
Nitrile rubber										○		•	
Polyurethane	•	•	•							•	•	○	
Diffuser ring													
Nitrile rubber				•	•	•	•	•	•	○		•	
Polyurethane	•	•	•				○	○	○	○	•	•	○
Screws and nuts													
Stainless steel	•	•	•	•	•	•	•	•	•	•	•	•	
O-rings													
Nitrile rubber	•	•	•	•	•	•	•	•	•	•	•	•	

For further information, see data sheets.

Specifications can be changed without notice.

• Standard ○ Option

Sludge pumps

Grindex sludge pumps are designed for professional use in tough applications like mines, construction sites, tunnel sites and other demanding industries.

They are designed for:

- Pumping water with high content of solids, up to the size of 80 mm.
- Pumping water which contains abrasive particles
- Pumping different types of mud and sludge
- Pumping light slurry

The pumps are designed for continuous, unattended operation. They have proven their reliability and dependable performance in demanding areas like building and construction, mining, tunnelling, quarries, industries, car washes and rental applications.



This page is a "target image" for the Grindex-app with 3D and Augmented Reality functions

FEATURES

Sludge Pumps

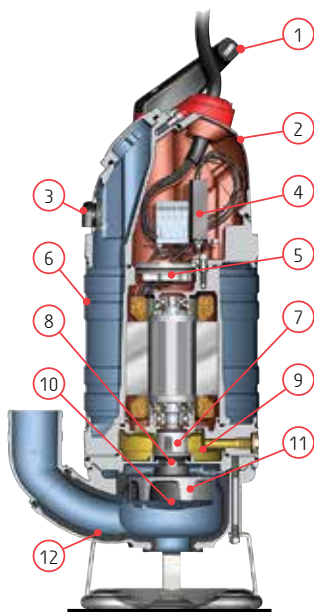

1. Ergonomic handle with a rubber grip on a metal frame
2. Inspection cover with large opening for easy access to junction box
3. Air valve cools the pump when no water is pumped
4. SMART motor protection including phase-failure guard, temperature guard and phase-sequence control eliminating the need for external start box
5. Enhanced terminal board with quick release terminal plate and sealing function
6. Durable outer jacket made from corrugated stainless steel
7. Easy service cartridge seal in rugged metal housing for improved heat transfer and longer pump life
8. Built-in particle repeller carries particles away from the seal for increased pump life
9. Simplified oil inspection and service, thanks to external plugs
10. Single adjustment screw for easy adjustment of the impeller and better performance
11. Hard-Iron™ impeller for maximum durability and performance
12. Heavy-duty polyurethane coating

SOLID

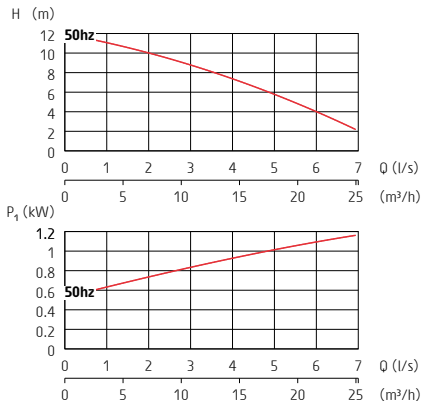

Technical Data 50 Hz

Solid

Pump type	8123.281
Discharge connection	2"
Rated power P ₂	900 W
Max. power cons. P ₁	1200 W
Shaft speed	2800 RPM
Rated current at 115V	11 A
Rated current at 230V	5.2 A
Solids passage	38 mm
Max. height	510 mm
Max. width	263 mm
Weight	17 kg

For further information, see data sheets. Specifications can be changed without notice.

SALVADOR

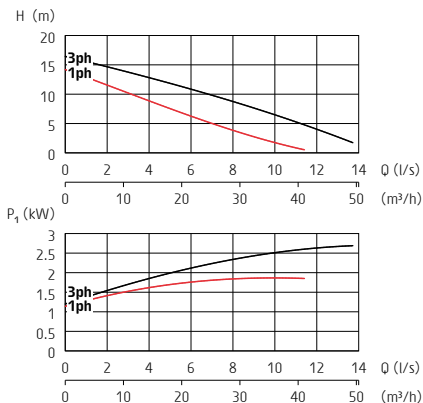

Technical Data 50 Hz

Salvador 1 ph

Salvador 3 ph

Pump type	8109.282	8109.282
Discharge connection	3"	3"
Rated power P ₂	1.5 kW	2.2 kW
Max. power cons. P ₁	1.9 kW	2.7 kW
Shaft speed	2830 RPM	2800 RPM
Rated current at 230V	8.4 A	8.1 A
Rated current at 400V	-	4.5 A
Rated current at 500V	-	3.6 A
Solids passage	50 mm	50 mm
Max. height	782 mm	782 mm
Max. width	360 mm	360 mm
Weight	33 kg	33 kg

For further information, see data sheets. Specifications can be changed without notice.

SENIOR

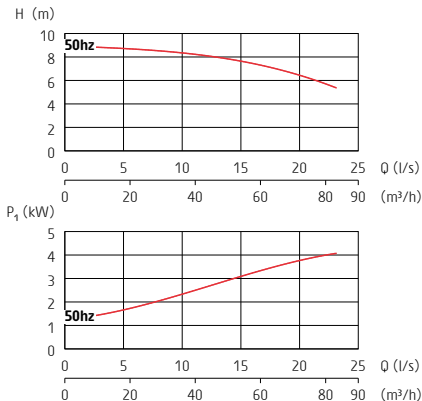

Technical Data 50 Hz

Senior N

Pump type	8110.281
Discharge connection	4"
Rated power P ₂	3.2 kW
Max. power cons. P ₁	4.2 kW
Shaft speed	1400 RPM
Rated current at 230V	13 A
Rated current at 400V	7.6 A
Rated current at 500V	6.0 A
Solids passage	80 mm
Max. height	867 mm
Max. width	480 mm
Weight	56 kg

For further information, see data sheets. Specifications can be changed without notice.

SANDY

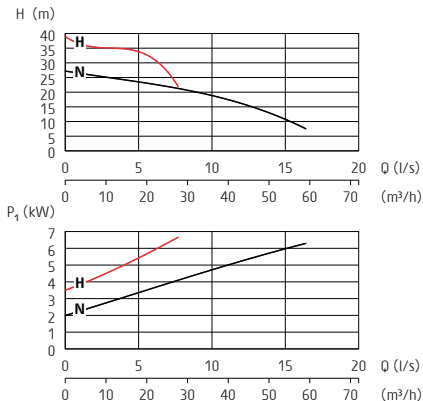

Technical Data 50 Hz

Sandy N

Sandy H

Pump type	8111.281	8111.281
Discharge connection	3"	3"
Rated power P ₂	5.6 kW	5.6 kW
Max. power cons. P ₁	6.7 kW	6.7 kW
Shaft speed	2890 RPM	2890 RPM
Rated current at 230V	19 A	19 A
Rated current at 400V	11 A	11 A
Rated current at 500V	8.7 A	8.7 A
Solids passage	46 mm	32 mm
Max. height	867 mm	867 mm
Max. width	460 mm	430 mm
Weight	56 kg	56 kg

For further information, see data sheets. Specifications can be changed without notice.

Materials in sludge pumps

	Solid	Salvador	Senior	Sandy
Material				
Inner seal				
Tungsten carbide - Aluminium oxide		•	•	•
Carbon - Aluminium oxide	•			
Outer seal				
Silicon carbide - Silicon carbide	•	•	•	•
Stator housing				
Aluminium	•	•	•	•
Outer casing				
Stainless steel		•	•	•
Aluminium	•			
Motor shaft				
Stainless steel	•	•	•	•

For further information, see data sheets. Specifications can be changed without notice.

Materials in sludge pumps

	Solid	Salvador	Senior	Sandy
Material				
Impeller				
Hard-Iron™		•	•	•
Polyurethane	•			
Pump housing				
Polyurethane	•			
Aluminium with polyurethane lining		•	•	•
Screws and nuts				
Stainless steel	•	•	•	•
O-rings				
Nitrile rubber	•	•	•	•
Casted parts				
Aluminium	•	•	•	•

For further information, see data sheets. Specifications can be changed without notice.

Drainage pumps made of stainless steel, INOX

These pumps are designed to meet the tough requirements from mines, construction sites, landfill sites and other applications that deal with corrosive water. One application is in mines where the water becomes caustic and destroys conventional pumps in matter of days. The pumps may also be used in applications where saltwater is pumped, like shipyards, fish farms, construction works in harbours and offshore projects. All INOX pumps can handle pH values from 2 - 10. They can also be equipped with zinc anodes for extra protection.

FEATURES

Inox Drainage Pumps

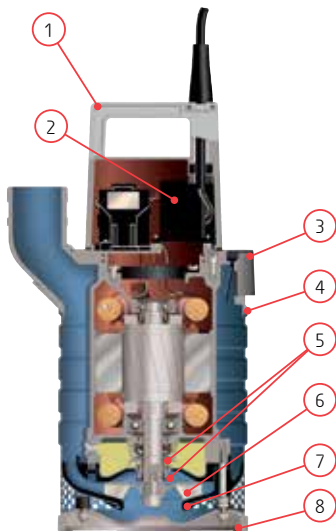

1. All steel parts are made of stainless steel
2. SMART motor protection including phase-failure guard, temperature guard, phase-sequence control and plug-&-play eliminating the need for external starter box
3. Air valve cools the pump when the pump is running dry
4. Durable outer casing made from corrugated stainless steel
5. Aquatite INOX - Double mechanical shaft seals with an oil compartment between the seals for longer pump life
6. Stainless steel impeller
7. Rubber lined adjustable diffusers to maintain optimum performance
8. Durable strainer in stainless steel with ergonomic grip

MINETTE INOX

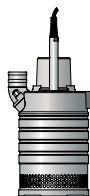
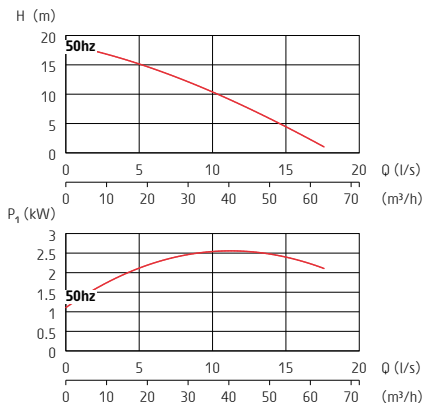

Technical Data 50 Hz

Minette Inox N

Pump type	8115.390
Discharge connection	3"
Rated power P ₂	2.0 kW
Max. power cons. P ₁	2.6 kW
Shaft speed	2715 RPM
Rated current at 230V	7.7 A
Rated current at 400V	4.4 A
Rated current at 500V	3.4 A
Solids passage	7.5 mm
Max. height	535 mm
Max. width	300 mm
Weight	44 kg

For further information, see data sheets. Specifications can be changed without notice.

MAJOR INOX

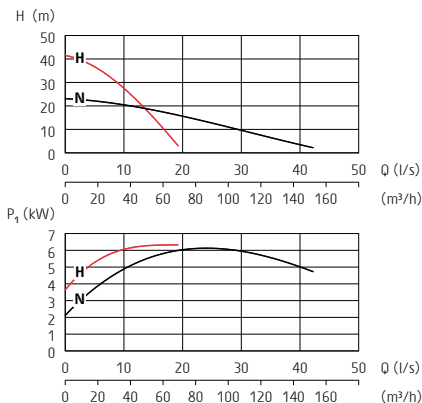
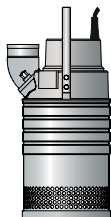

Technical Data 50 Hz

Major Inox N

Major Inox H

Pump type	8116.390	8116.390
Discharge connection	4"	3"
Rated power P ₂	6.3 kW	6.3 kW
Max. power cons. P ₁	7.3 kW	7.3 kW
Shaft speed	2840 RPM	2840 RPM
Rated current at 230V	-	-
Rated current at 400V	12 A	12 A
Rated current at 500V	9.4 A	9.4 A
Solids passage	8.5 mm	8.5 mm
Max. height	665 mm	665 mm
Max. width	333 mm	333 mm
Weight	65 kg	65 kg

For further information, see data sheets. Specifications can be changed without notice.

MASTER INOX

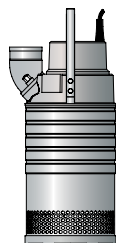
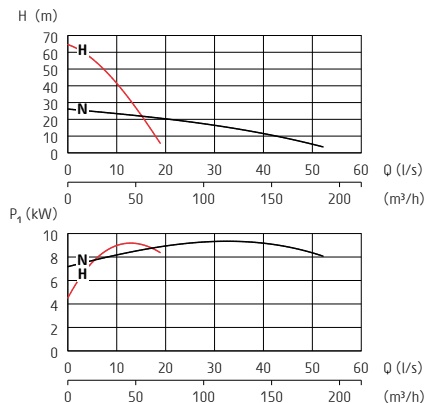

Technical Data 50 Hz

Master Inox N

Master Inox H

Pump type	8117.390	8117.390
Discharge connection	4"	3"
Rated power P ₂	8.0 kW	8.0 kW
Max. power cons. P ₁	9.2 kW	9.2 kW
Shaft speed	2855 RPM	2855 RPM
Rated current at 230V	-	-
Rated current at 400V	15 A	15 A
Rated current at 500V	12 A	12 A
Solids passage	8.5 mm	8.5 mm
Max. height	720 mm	720 mm
Max. width	333 mm	333 mm
Weight	77 kg	81 kg

For further information, see data sheets. Specifications can be changed without notice.

MEGA INOX

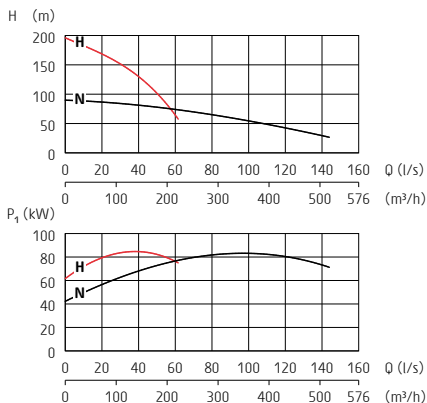
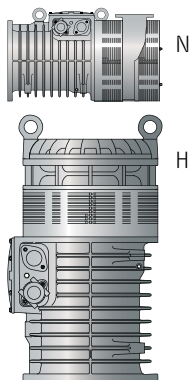

Technical Data 50 Hz

Mega Inox N

Mega Inox H

Pump type	8124.390	8124.390
Discharge connection	6"	4"
Rated power P ₂	85 kW	85 kW
Max. power cons. P ₁	90 kW	90 kW
Shaft speed	2965 RPM	2965 RPM
Rated current at 400V	141 A	141 A
Rated current at 500V	111 A	111 A
Rated current at 1000V	56 A	56 A
Solids passage	10 mm	10 mm
Max. height	770 mm	1250 mm
Diameter	620 mm	620 mm
Max. width	1180 mm	700 mm
Weight	925 kg	1015 kg

For further information, see data sheets. Specifications can be changed without notice.

Materials in drainage pumps made of stainless steel

	Minette INOX	Major INOX	Master INOX	Mega INOX
Material				
Inner seal				
Carbon - Silicon carbide	•	•	•	
Tungsten carbide - Tungsten carbide				•
Outer seal				
Silicon carbide - Silicon carbide	•	•	•	•
Casted parts				
Stainless steel (EN 10283-1.14412)	•	•	•	•
Outer casing				
Stainless steel (EN 10088-3-1.14436)	•	•	•	•

For further information, see data sheets. Specifications can be changed without notice.

Materials in drainage pumps made of stainless steel

	Minette INOX	Major INOX	Master INOX	Mega INOX
Material				
Motor shaft				
Stainless steel (EN 10088-3-1.14460)	•	•	•	•
Impeller				
Stainless steel (EN 10283-1.14412)	•	•	•	•
Screws and nuts				
Stainless steel (A4)	•	•	•	•
O-rings				
Viton rubber	•	•	•	•
Diffusers				
Nitrile rubber	•	•	•	•

For further information, see data sheets. Specifications can be changed without notice.

Sludge pumps made of stainless steel, INOX

Our sludge pumps in stainless steel are used for pumping corrosive fluids with solids in harsh environment. The solids can be up to the size of 50 mm. These pumps are designed to meet the tough requirements from mines, construction sites, landfill sites and other applications that deal with corrosive water. One application is in mines where the water becomes caustic and destroys conventional pumps in matter of days. The pumps may also be used in applications where saltwater is pumped, like shipyards, fish farms, construction works in harbours and offshore projects. All INOX pumps can handle pH values from 2 - 10. They can also be equipped with zinc anodes for extra protection.

FEATURES

Inox Sludge Pumps

1. All steel parts are made of stainless steel
2. SMART motor protection including phase-failure guard, temperature guard, phase-sequence control and plug-&-play eliminating the need for external starter box
3. Air valve cools the pump when the pump is running dry
4. Durable outer casing made from corrugated stainless steel
5. Aquatite INOX - Double mechanical shaft seals with an oil compartment between the seals for longer pump life
6. Stainless steel impeller
7. Highly abrasive- and oil-resistant rubber lined pump housing

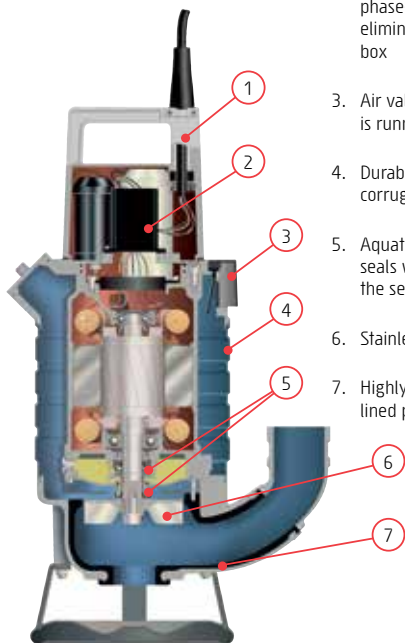

SALVADOR INOX

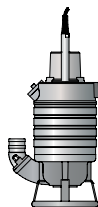
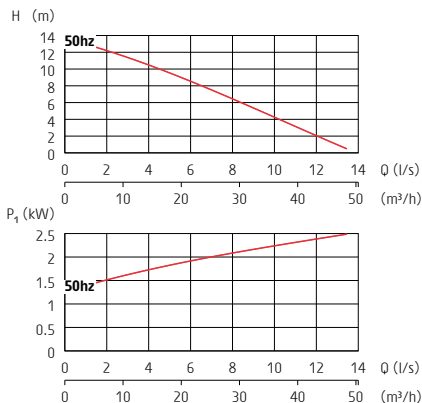

Technical Data 50 Hz

Salvador Inox 3 ph

Pump type	8118.280
Discharge connection	3"
Rated power P2	2.0 kW
Max. power cons. P1	2.7 kW
Shaft speed	2800 RPM
Rated current at 230V	7.7 A
Rated current at 400V	4.4 A
Rated current at 500V	3.4 A
Solids passage	50 mm
Max. height	645 mm
Max. width	375 mm
Weight	47 kg

For further information, see data sheets. Specifications can be changed without notice.

SENIOR INOX

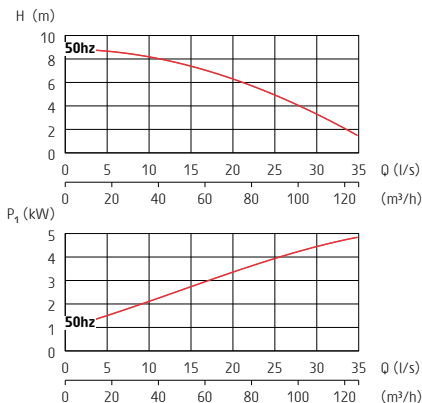
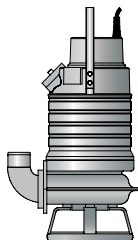

Technical Data 50 Hz

Senior Inox 3 ph

Pump type	8119.280
Discharge connection	4"
Rated power P2	4.1 kW
Max. power cons. P1	5.2 kW
Shaft speed	1350 RPM
Rated current at 230V	15 A
Rated current at 400V	8.8 A
Rated current at 500V	7.7 A
Solids passage	80 mm
Max. height	755 mm
Max. width	480 mm
Weight	86 kg

For further information, see data sheets. Specifications can be changed without notice.

SANDY INOX

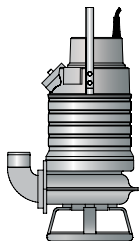
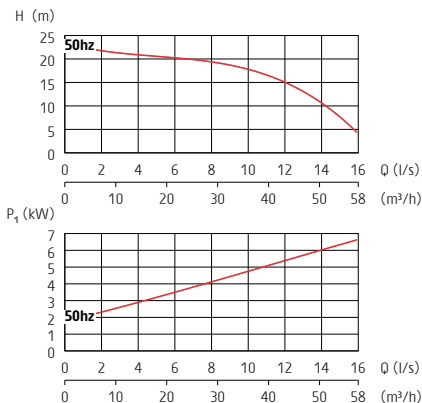

Technical Data 50 Hz

Sandy Inox 3 ph

Pump type	8120.280
Discharge connection	3"
Rated power P ₂	6.3 kW
Max. power cons. P ₁	7.3 kW
Shaft speed	2840 RPM
Rated current at 230V	-
Rated current at 400V	12 A
Rated current at 500V	9.4 A
Solids passage	46 mm
Max. height	755 mm
Max. width	480 mm
Weight	86 kg

For further information, see data sheets. Specifications can be changed without notice.

Materials in sludge pumps made of stainless steel

	Salvador INOX	Senior INOX	Sandy INOX
Material			
Inner seal			
Carbon - silicon carbide	•	•	•
Outer seal			
Silicon carbide - silicon carbide	•	•	•
Casted parts			
Stainless steel (EN 10283-1.14412)	•	•	•
Outer casing			
Stainless steel (EN 10088-3-1.14436)	•	•	•
Motor shaft			
Stainless steel (EN 10088-3-1.14460)	•	•	•
Impeller			
Stainless steel (EN 10283-1.14412)	•	•	•
Screws and nuts			
Stainless steel (A4)	•	•	•
O-rings			
Viton rubber	•	•	•
Pump housing			
Nitrile rubber	•	•	•

For further information, see data sheets. Specifications can be changed without notice.

Slurry pumps, BRAVO

Grindex slurry pumps are designed for use in quarries, mines, dredging, cleaning of settling ponds, other abrasive and other applications and industries that require pumps with very high durability. Each part of the BRAVO pump is designed for maximum endurance and reliability – an absolute must when pumping slurry. All BRAVO pumps can handle liquids with pH values from 5.5 up to 14.

The Bravo 400 to 900 are equipped with agitator beneath the pump intake to stir up settled material toward the pump intake. The Bravo 400 to 900 can also be fitted with an optional cooling jacket for use in dry pit applications.

Pumping slurry

Pumping fluids with high solids concentrations is more complicated than pumping water. To avoid sedimentation in the system you need to choose the right pump size and dimensions of hoses and pipes. The concentration of solids together with their size and shape may also affect pump performance and power requirements and therefore pump choice. Remember that settled solids might need external agitators, water jets or mixers to get them back in suspension and allow them to be pumped.

As each application requires its own calculation, we recommend you to contact your Grindex dealer for more information about slurry pumping.

FEATURES

Slurry Pumps

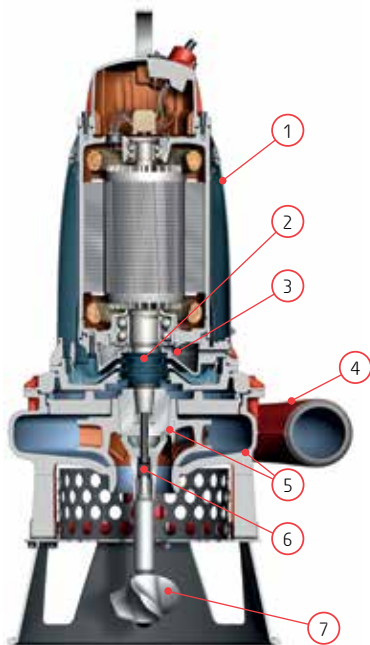

1. Optional cooling jacket for use in dry pit applications
2. Ready to install cartridge seal
3. Leakage sensor
4. Large throughlet handles solids of varying sizes
5. Hard-Iron™ impeller and pump housing for maximum durability and performance
6. Single adjustment sleeve unit for easy adjustment of the impeller
7. Agitator stirs up sand, sludge and solids in suspension

BRAVO 200

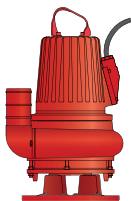
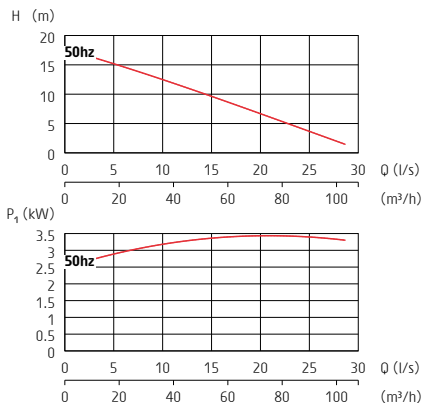

Technical Data 50 Hz

Bravo 200

Pump type	8146.020
Discharge connection	4"
Rated power P ₂	4.7 kW
Max. power cons. P ₁	5.7 kW
Shaft speed	1445 RPM
Rated current at 230V	17 A
Rated current at 400V	9.6 A
Rated current at 500V	7.7 A
Solids passage	50 mm
Max. height	760 mm
Max. width	460 mm
Weight	157 kg

Also available in EX (Explosion Proof) version.

For further information, see data sheets. Specifications can be changed without notice.

BRAVO 300

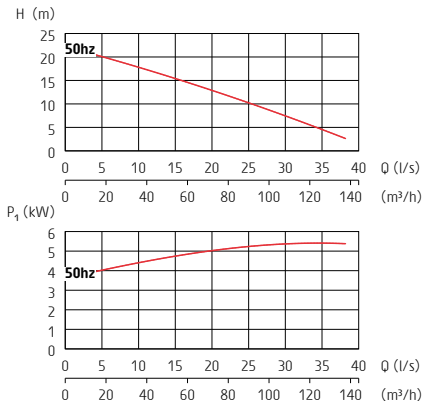
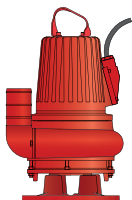

Technical Data 50 Hz

Bravo 300

Pump type	8147.020
Discharge connection	4"
Rated power P2	5.9 kW
Max. power cons. P1	7.1 kW
Shaft speed	1450 RPM
Rated current at 230V	21 A
Rated current at 400V	12 A
Rated current at 500V	9.5 A
Solids passage	50 mm
Max. height	760 mm
Max. width	460 mm
Weight	157 kg

Also available in EX (Explosion Proof) version.

For further information, see data sheets. Specifications can be changed without notice.

BRAVO 400

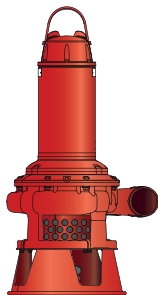
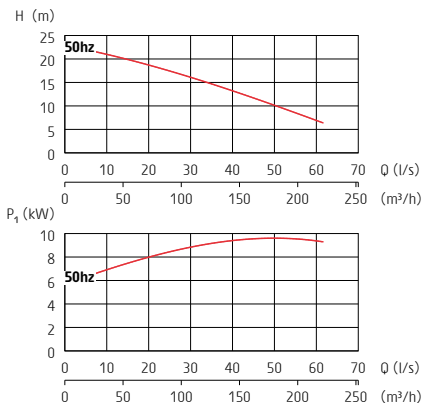

Technical Data 50 Hz

Bravo 400

Pump type	8148.020
Discharge connection	4"
Rated power P ₂	13.5 kW
Max. power cons. P ₁	16 kW
Shaft speed	1455 RPM
Rated current at 230V	47 A
Rated current at 400V	28 A
Rated current at 500V	21 A
Solids passage	30 mm
Max. height	1148 mm
Max. width	595 mm
Weight	231 kg

Also available in EX (Explosion Proof) version.

For further information, see data sheets. Specifications can be changed without notice.

BRAVO 500

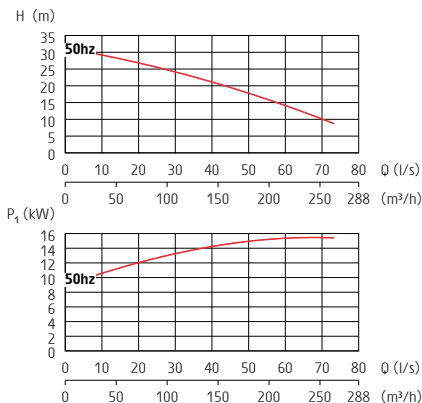
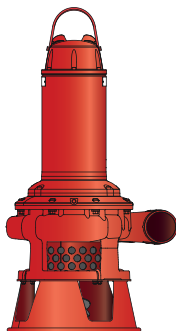

Technical Data 50 Hz

Bravo 500

Pump type	8149.020
Discharge connection	4"
Rated power P2	18 kW
Max. power cons. P1	21 kW
Shaft speed	1460 RPM
Rated current at 230V	62 A
Rated current at 400V	36 A
Rated current at 500V	29 A
Solids passage	40 mm
Max. height	1273 mm
Max. width	595 mm
Weight	293 kg

Also available in EX (Explosion Proof) version.

For further information, see data sheets. Specifications can be changed without notice.

BRAVO 600

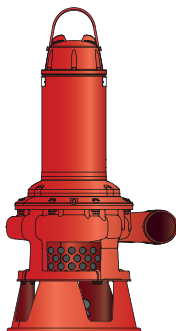
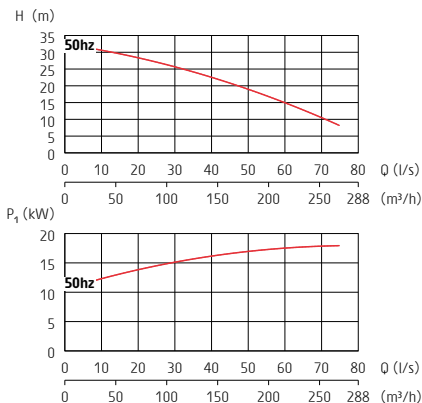

Technical Data 50 Hz

Bravo 600

Pump type	8150.020
Discharge connection	4"
Rated power P ₂	22 kW
Max. power cons. P ₁	25 kW
Shaft speed	1460 RPM
Rated current at 230V	73 A
Rated current at 400V	41 A
Rated current at 500V	33 A
Solids passage	40 mm
Max. height	1273 mm
Max. width	595 mm
Weight	293 kg

Also available in EX (Explosion Proof) version.

For further information, see data sheets. Specifications can be changed without notice.

BRAVO 700

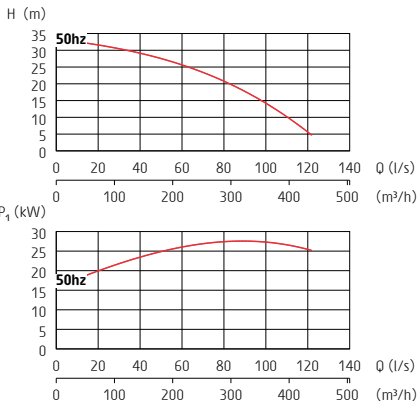
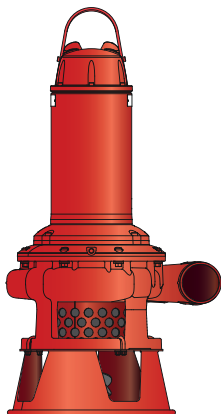

Technical Data 50 Hz

Bravo 700

Pump type	8151.020
Discharge connection	6"
Rated power P2	37 kW
Max. power cons. P1	40 kW
Shaft speed	1475 RPM
Rated current at 230V	-
Rated current at 400V	66 A
Rated current at 500V	54 A
Solids passage	36 mm
Max. height	1652 mm
Max. width	875 mm
Weight	613 kg

Also available in EX (Explosion Proof) version.

For further information, see data sheets. Specifications can be changed without notice.

BRAVO 800

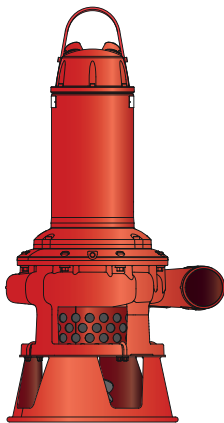
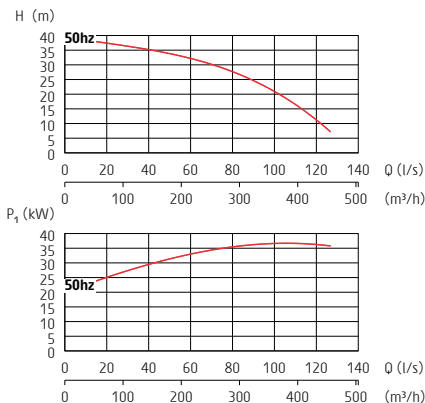

Technical Data 50 Hz

Bravo 800

Pump type	8152.020
Discharge connection	6"
Rated power P ₂	45 kW
Max. power cons. P ₁	49 kW
Shaft speed	1475 RPM
Rated current at 230V	-
Rated current at 400V	82 A
Rated current at 500V	63 A
Solids passage	36 mm
Max. height	1652 mm
Max. width	875 mm
Weight	613 kg

Also available in EX (Explosion Proof) version.

For further information, see data sheets. Specifications can be changed without notice.

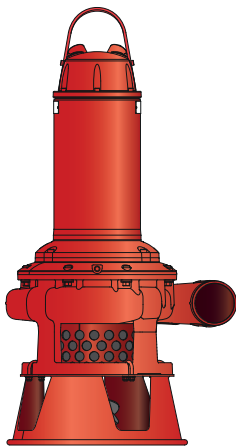

BRAVO 900

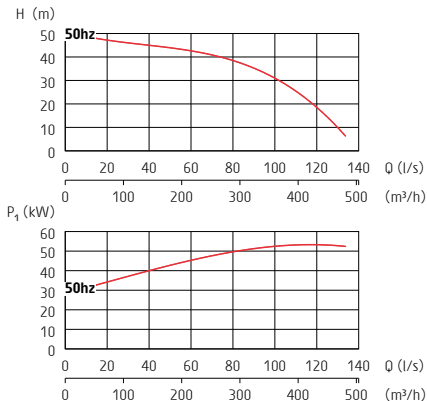

Technical Data 50 Hz

Bravo 900

Pump type	8153.020
Discharge connection	6"
Rated power P2	70 kW
Max. power cons. P1	75 kW
Shaft speed	1475 RPM
Rated current at 230V	-
Rated current at 400V	132 A
Rated current at 500V	102 A
Solids passage	36 mm
Max. height	1779 mm
Max. width	875 mm
Weight	845 kg

Also available in EX (Explosion Proof) version.

For further information, see data sheets. Specifications can be changed without notice.

Materials in slurry pumps

	Bravo 200	Bravo 300	Bravo 400	Bravo 500	Bravo 600	Bravo 700	Bravo 800	Bravo 900
Material								
Inner seal								
Tungsten carbide - Aluminium oxide	•	•						
Tungsten carbide - Tungsten carbide			•	•	•	•	•	•
Outer seal								
Tungsten carbide - Tungsten carbide	•	•	•	•	•	•	•	•
Drive unit								
Cast iron	•	•	•	•	•	•	•	•
Suction cover								
Nitrile rubber	•	•	-	-	-	-	-	-
Pumphousing								
Cast iron	•	•	-	-	-	-	-	-
Hard-Iron™	-	-	•	•	•	•	•	•
Discharge connection type								
Thread or hose connection	•	•	-	-	-	-	-	-
Victualic connection	-	-	○	○	○	○	○	○

For further information, see data sheets.
Specifications can be changed without notice.

• Standard ○ Option - Not available

Materials in slurry pumps

	Bravo 200	Bravo 300	Bravo 400	Bravo 500	Bravo 600	Bravo 700	Bravo 800	Bravo 900
Material								
Agitator								
Hard-Iron™	-	-	•	•	•	•	•	•
Impeller								
Hard-Iron™	•	•	•	•	•	•	•	•
Lifting handle								
Galvanised steel	•	•	-	-	-	-	-	-
Stainless steel	-	-	•	•	•	•	•	•
Motor shaft								
Stainless steel	•	•	•	•	•	•	•	•
Studs, screws and nuts								
Stainless steel	•	•	•	•	•	•	•	•

For further information, see data sheets.
Specifications can be changed without notice.

• Standard ○ Option - Not available

Primo pumps

Grindex Primo is a range of small, handy and affordable pumps, including two drainage and two sludge pumps. The Primo pumps are ideal for construction, industrial and municipal jobs, and the highly compact design allows the Primo pumps to operate in dewatering applications where others don't fit.

PRIMO D4

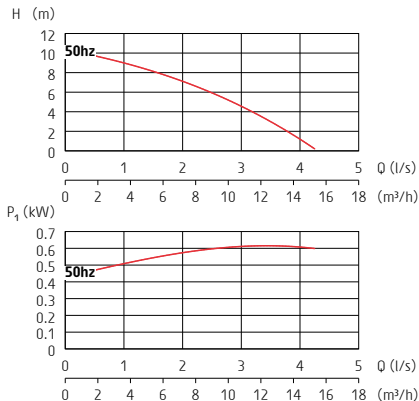

Technical Data 50 Hz

Primo D4

Pump type	5182210
Discharge connection	2"
Rated power P2	400 W
Max. power cons. P1	650 W
Shaft speed	2800 RPM
Rated current at 115V	5.8 A
Rated current at 230V	2.8 A
Solids passage	7.5 mm
Max. height	340 mm
Max. width	183 mm
Weight	9 kg

For further information, see data sheets. Specifications can be changed without notice.

PRIMO D8

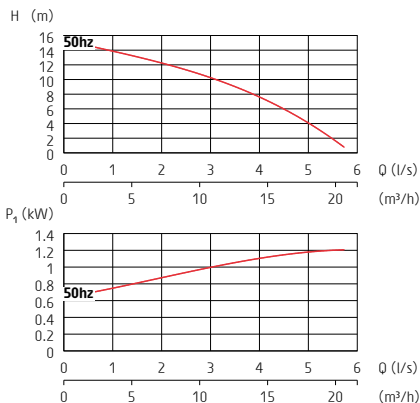

Technical Data 50 Hz

Primo D8

Pump type	5182230
Discharge connection	2"
Rated power P ₂	750 W
Max. power cons. P ₁	1200 W
Shaft speed	2800 RPM
Rated current at 115V	10.6 A
Rated current at 230V	5.2 A
Solids passage	7.5 mm
Max. height	384 mm
Max. width	183 mm
Weight	13 kg

For further information, see data sheets. Specifications can be changed without notice.

PRIMO S4

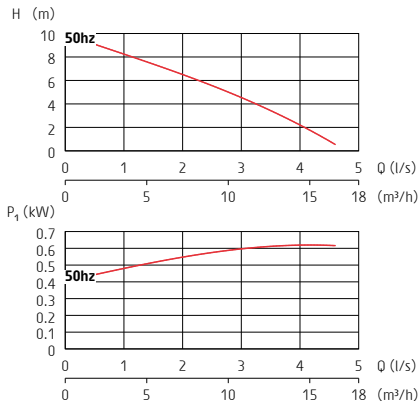
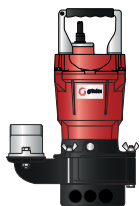

Technical Data 50 Hz

Primo S4

Pump type	5182220
Discharge connection	2"
Rated power P2	400 W
Max. power cons. P1	650 W
Shaft speed	2800 RPM
Rated current at 115V	5.8 A
Rated current at 230V	2.8 A
Solids passage	25 mm
Max. height	373 mm
Max. width	241 mm
Weight	10 kg

For further information, see data sheets. Specifications can be changed without notice.

PRIMO S8

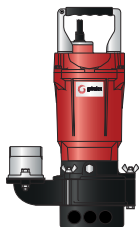
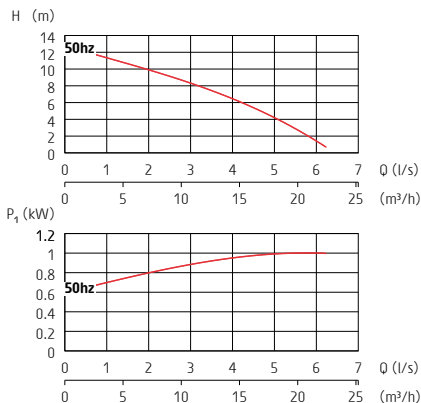

Technical Data 50 Hz

Primo S8

Pump type	5182240
Discharge connection	2"
Rated power P ₂	750 W
Max. power cons. P ₁	1200 W
Shaft speed	2800 RPM
Rated current at 115V	10.6 A
Rated current at 230V	5.2 A
Solids passage	25 mm
Max. height	416 mm
Max. width	241 mm
Weight	13 kg

For further information, see data sheets. Specifications can be changed without notice.

Materials in Primo pumps

	Primo D4	Primo D8	Primo S4	Primo S8
Material				
Inner seal				
Silicon carbide - Silicon carbide	•	•	•	•
Outer seal				
Silicon carbide - Silicon carbide	•	•	•	•
Pump top				
Aluminium	•	•	•	•
Outer casing				
Steel	•	•	-	-
Stator housing				
Aluminium	•	•	•	•
Motor shaft				
Stainless steel	•	•	•	•
Impeller				
Cast iron	-	-	•	•
Polyurethane	•	•	-	-
Diffuser				
Cast iron	•	•	•	•
Screws and nuts				
Stainless steel	•	•	•	•

For further information, see data sheets. Specifications can be changed without notice.

Accessories

Some applications require the use of additional devices. Here is a list of Grindex accessories and what pump they can be used with.

- Available
- Not an optimal choice
- x Not available
- Together with external starter
- () Letter in parentheses refer to pump model

	Zinc anodes	Low suction collar	Float switch	Tandem connection	Pump raft
Drainage pumps					
Micro	X	●	●	X	●
Milli	X	X	○	X	○
Mini	X	●	●	X	●
Minex	●	●	●	X	●
Minette	●	●	●	X	●
Minor	●	●	●	●	●
Major	●	●	●	●	●
Master	●	X	●	●	●
Matador	●	X	●	●	●
Maxi	●	X	□	●	●
Magnum	●	X	□	● (H)	●
Mega	●	X	□	X	●

Sludge pumps					
Solid	X	X	●	X	○
Salvador	●	X	●	X	○
Senior	●	X	●	X	○
Sandy	●	X	●	X	○

For further information, see data sheets. Specifications can be changed without notice.

Accessories

	Zinc anodes	Low suction collar	Float switch	Tandem connection	Pump raft
Drainage pumps made of stainless steel					
Minette Inox	●	●	□	X	○
Major Inox	●	●	□	X	○
Master Inox	●	●	□	X	○
Mega Inox	●	X	□	X	●
Sludge pumps made of stainless steel					
Salvador Inox	●	X	□	X	○
Senior Inox	●	X	□	X	○
Sandy Inox	●	X	□	X	○
Slurry pumps					
Bravo 200	●	X	□	X	●
Bravo 300	●	X	□	X	●
Bravo 400	●	X	□	X	●
Bravo 500	●	X	□	X	●
Bravo 600	●	X	□	X	●
Bravo 700	●	X	□	X	●
Bravo 800	●	X	□	X	●
Bravo 900	●	X	□	X	●
Primo pumps					
Primo D4	X	X	○	X	●
Primo D8	X	X	○	X	●
Primo S4	X	X	○	X	●
Primo S8	X	X	○	X	●

For further information, see data sheets. Specifications can be changed without notice.

Grindex Pump School

The school consists of technical articles, intended to help pump users with common matters in pumping with submersible pumps.

Part 1: Choosing the right pump type for the job

A drainage pump is the most commonly used pump type at construction sites. It is used for pumping water with less abrasive solids, like clay. Sand and solids in suspension can also be pumped, up to the size of the strainer holes (normally 7-12 mm). As sand is quite abrasive to the pump, it must not be too concentrated.



Sludge pumps are suitable for pumping water with solids, as well as for pumping sludge. The solids can be up to the size of the pump inlet diameter (normally 32-80 mm).



Pumps made of stainless steel are often used in copper mines, gold mines and other applications with corrosive fluids. An aluminium pump can handle water with pH values from 5-8, while a stainless steel pump can cope with pH values from 2-10.



Slurry pumps are designed to handle abrasive solids in suspension, like sand, gravel and concrete, in high concentration. They are also frequently used to move sand in suspension, i.e. at a dredging operation. To cope with the abrasives, the hydraulic parts of a slurry pump are often made of a very hard metal alloy. For improved performance, bigger slurry pumps can be equipped with agitator.



Plug and pump

An electrical submersible pump is easy to use, just plug it in and pump. Several small pumps, placed where the need is for the moment, can pump the water to a dedicated collecting pit through long hoses. As the smaller pumps only weights 10-25 kg, you can carry the pump with you as the works moves to different spots at the site.



In the collection pit, a bigger pump is installed and pumps the water away from the site. By connecting hoses from several pumps to the pit, you can easily dewater a large area with just a few pumps.



Part 2: Pump arrangement

Despite the simplicity, there are a few details to consider for optimizing the pumping:

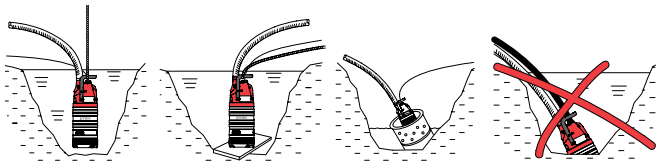

Arrange the pump so it doesn't burrow itself into sand or clay. This is a common problem at construction sites. It can be avoided quite simple by placing the pump on a bed of coarse gravel or a plank. The pump can also be hung freely by a rope or chain, or put into a cut-down and perforated oil drum.

Avoid sharp bend on the hose

As sharp bends, kinks and pinching of the hose are reducing the capacity of the pump, a lot is won by avoiding those circumstances. Turning the pumps discharge connection so the hose doesn't begin with at kink is easily arranged; it can be fitted vertical or horizontal on almost all Grindex pumps.

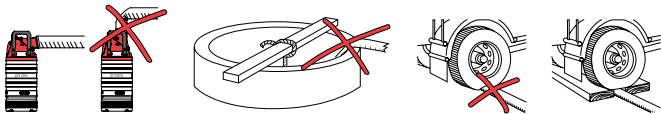

Tandem connection

In order to achieve higher pumping heads, two or more drainage pumps can be connected in series. For this purpose, a series connecting flange is available as an accessory. It is important that the hoses are equipped with check valves, preventing the pumps from suffering from wear when the water runs back from high heads uncontrolled if a power failure should occur.

Long distance pumping

Tandem connection of pumps can also be used when the water needs to be pumped a longer distance. A simple arrangement can be pumping the water to a dedicated collection pit. The pit should be equipped with another pump, passing the water on. This technique can also be used for dewatering a greater area with several pumps spread out, pumping the water to a collection pit. The pit is then equipped with a greater pump, that pumps the water away from the site.

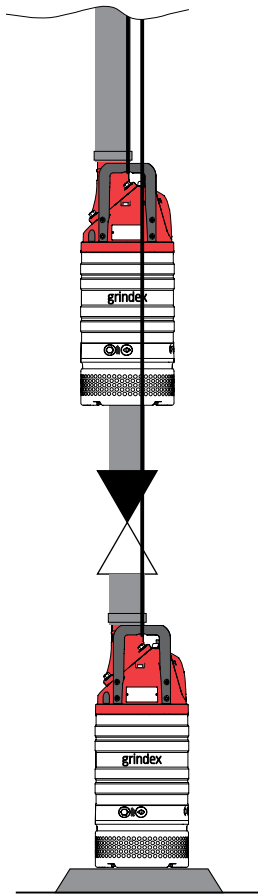

Part 3: Sedimentation

The pumped water is often containing solids that cause wear to pumps, valves and other dewatering equipment. This problem is very common in mines and tunnel construction sites. When pumping water that contains solids (like drill cuttings and sand), there is a risk of sedimentation in the system. A typical symptom is pipes and/or hoses that get filled with sediment, resulting in capacity losses. When the amount of solids increases, there is also an increase of wear on the pump.

One way to prevent this is by using sedimentation tanks where the drill cuttings may settle while the rest of the water is pumped away. The tank needs to be as close to the source as possible, ensuring that the solids are pumped as short distance as possible where the solids can settle in peace. To ensure the efficiency of the sedimentation tank, it needs to have as big surface area as possible. The more solids present in the water, the more care should be taken in the design of the sedimentation system.

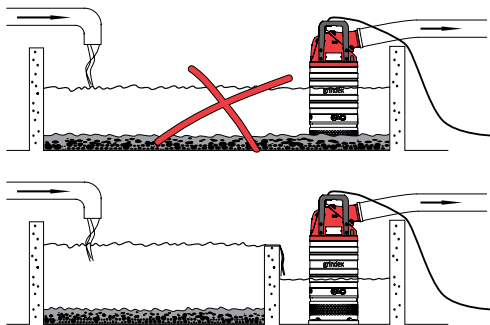

For applications where solids can not be avoided, there are recommendations for the velocity of the medium in the discharge line:

Mixture	Min. velocity in discharge line
1. Water + coarse gravel	4 m/s (13.1ft/s)
2. Water + gravel	3 m/s (11.5 ft/s)
3. Water + sand	
Sand particles < 0.1 mm (0.004 in)	1.5 m/s (8.2 ft/s)
Sand particles < 0.6 mm (0.024 in)	2.5 m/s (4.9 ft/s)



Limitations for Grindex pumps

Limitations	Drainage pumps	Sludge pumps
Max. submersion depth (IP68)	20 m (66 ft), except: Micro, Milli & Mini: 10 m (33 ft) Mega: 75 m (246 ft)	20 m (66 ft), except: Solid: (10 m)
Max. liquid temperature <i>Option: 70°C version*</i>	40°C (104°F) 70°C (158°F)	40°C (104°F) -
Max. liquid density	1100 kg/m ³ (68 lbs/ft ³)	1100 kg/m ³ (68 lbs/ft ³)
pH of the liquid	5-8 (except Mega: 6-13)	5-8

Limitations	Stainless steel pumps	Slurry pumps
Max. submersion depth (IP68)	20 m (66 ft)	20 m (66 ft)
Max. liquid temperature	40°C (104°F)	40°C (104°F)
Max. liquid density	1100 kg/m ³ (68 lbs/ft ³)	1300-1700 kg/m ³ (80-106 lbs/ft ³)
pH of the liquid	2-10	5.5 - 14

* Option: 70°C version - Drainage pumps:

Minex, Minette, Minor, Major, Master & Matador

Chart for calculating friction losses in hoses

All pump capacities are measured for clean water, directly at the discharge outlet. When connecting a hose you need to consider the friction losses that come from the size and length of the hose. The chart below shows this.

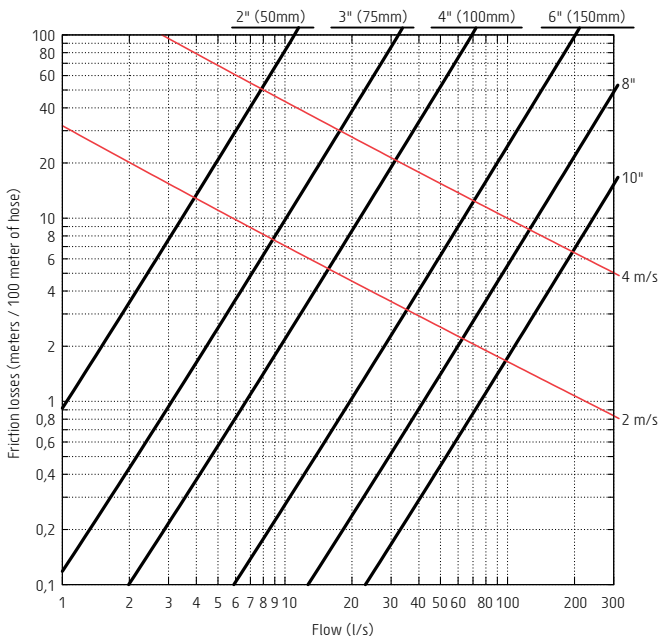

Formulas for calculating friction losses in hoses and tubes

The chart on page 73 was created using the following formulas:

Friction loss (meters)	Velocity (m/s)	Reynolds number	Friction factor (Swamee & Jain formula)
$\frac{H_{friction}}{1000} = \frac{f \times L \times v^2}{2 \times g \times D}$	$V = \frac{Q}{D^2}$	$Re = \frac{v \times D}{\mu}$	$f = \frac{0.25}{\left[\log \left(\frac{\epsilon}{3.7 \times D} + \frac{5.74}{Re^{0.9}} \right) \right]^2}$
<p>f = friction factor</p> <p>L = length (m)</p> <p>v = avg. velocity</p> <p>g = 9.81 m/s²</p> <p>D = pipe Ø (mm)</p>	<p>Q = flow (l/s)</p> <p>D = pipe Ø (mm)</p>	<p>v = velocity</p> <p>D = pipe Ø (mm)</p> <p>μ = viscosity = 1.161 x 10⁻⁶ m²/s = 1 cSt</p>	<p>ε = roughness factor (mm)</p> <p>D = pipe Ø (mm)</p> <p>Re = Reynolds number</p>

Friction factor

Material	Cast iron	Stainless	PVC	HDPE	Concrete	Hose
ε new (mm)	0.25	0.10	0.05	0.05	0.50	0.25
ε used (mm)	1.00	0.25	0.25	0.25	3.00	1.00

Sludge/slurry solids concentration

By volume (C _v)	By mass/weight (C _m)	Mixture
$C_v = \frac{V_{solids}}{V_{solids+water}}$	$C_m = \frac{m_{solids}}{m_{solids+water}}$	$\frac{SV_{mixture}}{SV_{solids}} = \frac{C_v}{C_m}$
<p>V_{solids} = volume of solids</p> <p>V_{solids+water} = total sludge volume</p>	<p>m_{solids} = mass of solids</p> <p>m_{solids+water} = total sludge mass</p>	<p>SV = Specific weight</p>

pH tables

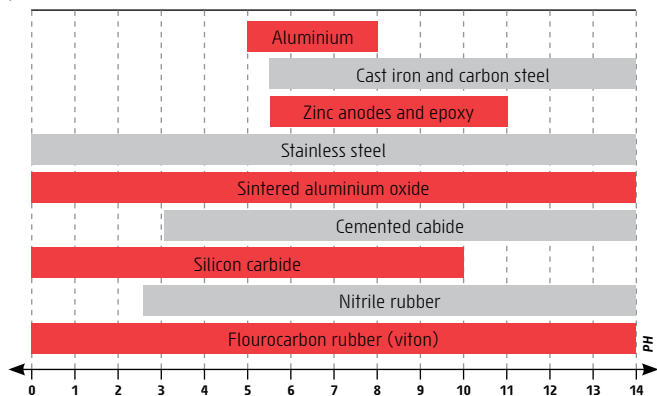

Salt tables

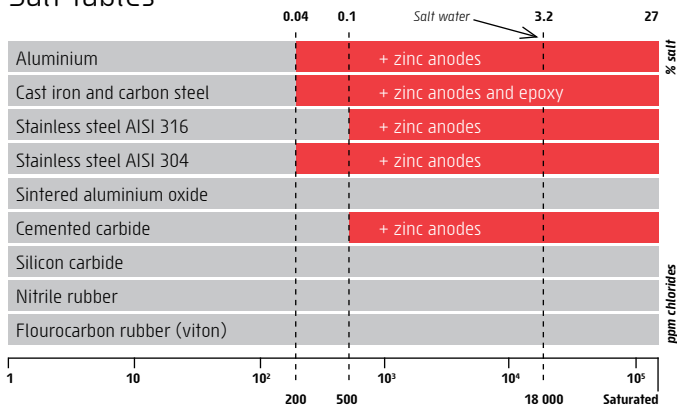

Translation charts

Pressure

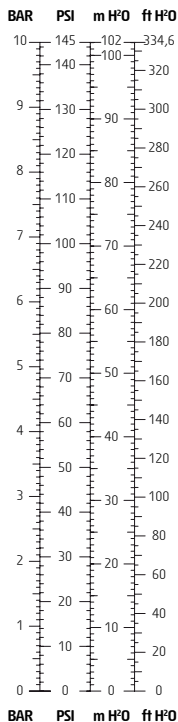

Effect

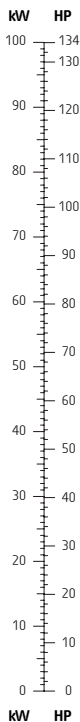

Flow

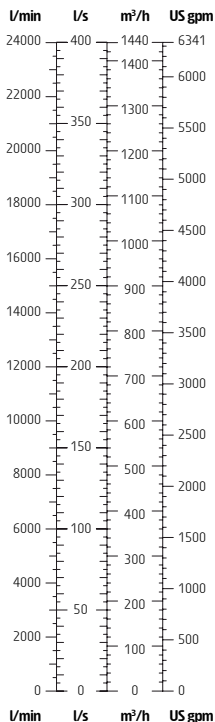

Temperature

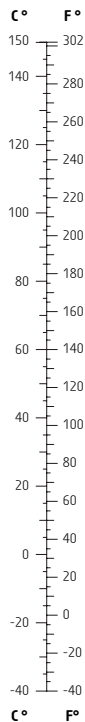

Recommended generator sizes

Voltages 3~400 V, 50 Hz

Pump model	Max. power consumption	Rated current	Permissible cable length**	Delayed fuse	Generator set
Minex	1.6 kW	2.7 A	220 m	10 A	5 KVA
Minette	2.7 kW	4.7 A	150 m	10 A	8 KVA
Minor N H	4.4 kW	7.3 A	160 m	16 A	13 KVA
Major N H	6.6 kW	11.0 A	110 m	25 A	18 KVA
Master N H SH	11.7 kW	19.0 A	100 m	32 A	25* / 30 KVA
Matador N H	20.0 kW	32.0 A	90 m	63 A	40* / 50 KVA
Maxi H Lite	28.0 kW	44.0 A	120 m	63 A	55* / 70 KVA
Maxi N H	41.0 kW	65.0 A	120 m	100 A	85* / 105 KVA
Maxi L	33.0 kW	57.0 A	120 m	100 A	70* / 85 KVA
Magnum	62.0 kW	107.0 A	120 m	190 A	125* / 155 KVA
Mega	95.0 kW	148.0 A	120 m	230 A	225* / 270 KVA
Minette Inox	2.6 kW	4.7 A	150 m	10 A	8 KVA
Major Inox	7.3 kW	12.0 A	110 m	25 A	20 KVA
Master Inox	9.2 kW	15 A	80 m	32 A	25 KVA
Salvador	2.7 kW	4.7 A	150 m	10 A	8 KVA
Senior	4.2 kW	9.0 A	130 m	25 A	13 KVA
Sandy	6.6 kW	11.0 A	110 m	25 A	18 KVA
Salvador Inox	2.7 kW	4.7 A	150 m	10 A	8 KVA
Senior Inox	5.2 kW	8.8 A	130 m	16 A	10 KVA
Sandy Inox	7.3 kW	12.0 A	110 m	25 A	18 KVA

*Y/D start **Valid for standard cable sizes

Recommended generator sizes

Voltages 1~230 V, 50 Hz

Pump model	Max. power consumption	Rated current	Permissible cable length*	Delayed fuse	Generator set
Micro/Milli	0.59 kW	2.7 A	50 m	10 A	3 KVA
Mini	1.2 kW	5.2 A	50 m	10 A	4 KVA
Minex Lite	1.1 kW	5.1 A	80 m	10 A	4 KVA
Minex	1.8 kW	7.8 A	50 m	16 A	5 KVA
Minette	1.9 kW	8.4 A	50 m	16 A	5 KVA
Solid	1.2 kW	5.2 A	50 m	10 A	4 KVA
Salvador	1.9 kW	8.4 A	50 m	16 A	5 KVA

*Valid for standard cable sizes

Note

- In general, delayed fuse shall be dimensioned by rated current x 1.75
- The above given kVA values are meant as guidelines to simplify the choice of generator size.

Regarding size of generator set, each different type has different characteristic; therefore it is always recommended to consult the manufacturer of generator to find out if the actual generator is capable of operating the pump.

Make sure that the cable is sized to allow a voltage drop of max. 5% of the nominal voltage.

Bolt Tightening Torque values

All screws and nuts must be lubricated to achieve correct tightening torque. Screws that are screwed into stainless steel must have the threads coated with suitable lubricants to prevent seizing.

Table 1: Stainless steel, A2 and A4, torque Nm (ft-lbs): Screws and nuts

Property class	M4	M5	M6	M8	M10	M12	M16	M20	M24	M30
50	1.0 (0.74)	2.0 (1.5)	3.0 (2.2)	8.0 (5.9)	15 (11)	27 (20)	65 (48)	127 (93.7)	220 (162)	434 (320)
70, 80	2.7 (2)	5.4 (4)	9.0 (6.6)	22 (16)	44 (32)	76 (56)	187 (138)	364 (268)	629 (464)	1240 (915)
100	4.1 (3)	8.1 (6)	14 (10)	34 (25)	66 (49)	115 (84.8)	248 (183)	481 (355)	-	-

Table 2: Steel, torque Nm (ft-lbs): Screws and nuts.

Property class	M4	M5	M6	M8	M10	M12	M16	M20	M24	M30
8.8	2.9 (2.1)	5.7 (4.2)	9.8 (7.2)	24 (18)	47 (35)	81 (60)	194 (143)	385 (285)	665 (490)	1310 (966)
10.9	4.0 (2.9)	8.1 (6)	14 (10)	33 (24)	65 (48)	114 (84)	277 (204)	541 (399)	935 (689)	1840 (1357)
12.9	4.9 (3.6)	9.7 (7.2)	17 (13)	40 (30)	79 (58)	136 (100)	333 (245)	649 (480)	1120 (825)	2210 (1630)

Hexagon screws with countersunk heads

For hexagon socket head screws with countersunk head, maximum torque for all property classes must be 80% of the values for property class 8.8 above.



See "Grindex App", our Augmented Reality interactive 3D app for looking inside a Grindex submersible drainage pump. Get the app at App Store or Play Store, and use the target image on page 5 in this handbook to see the 3D pump. It's free of course.



Grindex AB

Box 7025

SE-174 07 Sundbyberg, Sweden

Phone: +46 8 606 6600

Website: www.grindex.com