

LAYHER KEDER ROOF XL

INSTRUCTIONS FOR ASSEMBLY AND USE

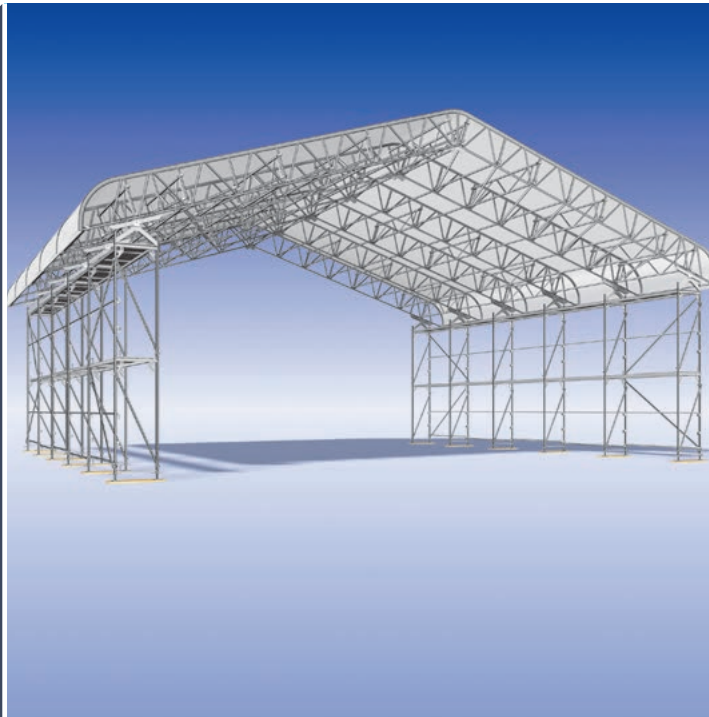

Edition 01.2014

Ref. No. 8114.261

Quality management
certified according to
DIN EN ISO 9001:2008
by TÜV-CERT



CONTENTS

1.	Introduction	4
2.	General.....	6
3.	Measures to prevent falls	7
4.	Assembly.....	7
	Assembly of supports and roof trusses	8
	Assembly of bracing elements.....	9
	Bracing variants.....	11
	Crane assembly – Variant 1	12
	Crane assembly – Variant 2.....	13
	Assembly of a mobile roof – Variant 3.....	15
5.	Assembly of tie.....	20
6.	Fitting of tarpaulins	21
7.	Weights of pre-assembled trusses and truss bays.....	22
8.	Spans and loads	23
	Double-pitch roof.....	25
	Mono-pitch roof.....	28
9.	Individual verification.....	30
10.	Components.....	32
	Systems – examples for assembly.....	37
	Double-pitch roof “Light”	37
	Double-pitch roof “Standard”	37
	Double-pitch roof “Heavy”	38
	Mono-pitch roof.....	38

NOTE

The products or assembly variants shown in these instructions for assembly and use may be subject to country-specific regulations. The user of the products bears the responsibility for compliance with such regulations. Subject to local regulations, we reserve the right not to supply all the products illustrated here.

Your Layher partner on the spot will be happy to provide advice and answers to all questions relating to the approvals for the products, to their use or to specific assembly regulations.

1. INTRODUCTION

General

These instructions for assembly and use relate to assembly, modification and dismantling of the main assembly variants of the Keder Roof XL from Wilhelm Layher GmbH & Co. KG, of Güglingen-Eibensbach, Germany. The instructions cannot cover all the possible applications. The support scaffolding must be built in accordance with the appropriate instructions for assembly and use of the scaffolding type used. If you have any questions about specific applications, please contact your Layher partner.

Caution: The stability of the enclosing structure (support scaffolding and Keder Roof XL) must be verified and assured at all times, including in the assembled state. The support scaffolding and Layher Keder Roof XL may only be assembled, modified and dismantled under the supervision of a qualified expert and by technically trained employees.

Only original Layher components may be used for assembly.

Visually check all components prior to installation and before they are used to ensure that they are in flawless condition. Do not use damaged components.

Caution: Assembly, alteration and dismantling of the overall structure involve risk of falls. Perform the assembly work in such a way that the risk of falls is avoided as far as possible and that the residual risk is minimized. Assembly situations where there is a risk of falls are indicated in these instructions with the following symbol (Fig. 1) inside the assembly pictures.



Fig. 1

The roof erector must stipulate, on the basis of how he assesses the risk, suitable measures to prevent or minimize risks for the specific case and/or for the respective activities involved.

The measures must be selected with due consideration of the actual risk, their usefulness and their practical possibilities, and also depending on

- the qualification of the employees,
- the type and duration of the activity in the high-risk area,
- the possible fall height,
- the nature of the surface onto which the employee might fall and
- the state of the workplace and its access.

Technical and personnel-related measures can be applied during assembly, modification and dismantling. Possible measures can include, depending on the assembly situation, the use of qualified personnel specifically informed of the respective risk situation, the use of the advance guard rail, or in specific cases the use of suitable personal safety apparatus. In any event, the assembly sequence must be designed such that side protection is installed at once, allowing personnel to work predominantly in secured areas.

If personal safety apparatus (PSA) is required for assembly work or is specified by local regulations, the attachment points stated in section 3 must be used. The suitability of PSA for fall prevention must be checked, with particular attention being given here to the height at which assembly work is being done.

Before the start of assembly work, the contractor must ascertain whether the planned working area contains equipment that might endanger the employees. Assembly, modification and dismantling may only be performed with appropriate safety apparatus. Components must not be thrown; instead they must be handed over in such a way that they cannot slip or be dropped.

Every use of the support scaffolding and of the Keder Roof XL must be preceded by a check that they are in good condition.

With regard to the following instructions for assembly and use of the Keder Roof XL system, it must be pointed out that as a general principle scaffolding and roofs may only be assembled, modified or dismantled under the supervision of a qualified person and by technically trained employees adequately and specifically instructed in this work. To that extent, and with regard to use, we refer to the required conditions set forth in German Ordinance on Industrial Safety and Health (BetrSichV). In the following instructions for assembly and use, we enable both the erector and the user, on the basis of our risk analysis, to comply with the requirements of the above ordinance in the respective assembly situation.

The technical details set forth in the instructions for assembly and use are intended to help the erector/user to comply with the requirements of the ordinance, and are not mandatory specifications for them. The erector/user must take the measures needed on the basis of the risk assessment, prepared according to the preconditions of the Ordinance, at his own discretion and exercising all due care and diligence. The specific features of the individual case must be taken into account here.

It is essential that the following instructions for assembly and use are complied with in every case. We would point out that all information, particularly that regarding stability of the assembly variants, applies only when original Layher components are used. The installation of non-Layher parts can lead to safety defects and insufficient stability.

The present instructions for assembly and use must be available to the supervisor and to the employees involved.

During assembly, modification and dismantling, as well as during use, the legal regulations of the German Ordinance on Industrial Safety and Health (BetrSichV) concerning the erection and use of scaffolding must be complied with.

Inspection and documentation

The overall structure (support scaffolding and Keder Roof XL) must be inspected by persons qualified to do so after it has been assembled and before it is put into service. This inspection must be documented. If certain areas are not ready for use, particularly during assembly, modification and dismantling, they must be identified with a prohibitory sign (Fig. 2) indicating "no entry". In addition, it must be made clear by barriers that the structure has not been completed and hence must not be accessed.



Fig. 2

After completion of the overall structure, it is useful to indicate that inspection has been passed by a clearly discernible identification for the duration of its use.

Use and identification marking

The user must check that the selected roof structure is suitable and safe to use for the work to be performed (Section 4 of BetrSichV). He must ensure that the overall structure is checked for obvious defects before use. If defects are found during this check, the overall structure may not be used in those areas where there are defects until these have been eliminated by the erector. Subsequent alterations are deemed as assembly, modification or dismantling and may only be performed by technically trained employees. They must be inspected and approved by the erector.

The legal regulations of the German Ordinance on Industrial Safety and Health must be complied with.

The snow loads and useful loads assumed during dimensioning must be indicated clearly and permanently. If a reduced snow load is assumed, it must be assured at all times, by the specification of suitable measures, that this characteristic snow load is not exceeded. A detailed list of articles can be found in our catalogue, and information on structural values in our technical documents.

2. GENERAL

Description

The Layher Keder Roof XL is a quick-to-assemble, lightweight and aesthetically attractive weather protection roof. It can be designed in double-pitch or mono-pitch form with different bracing variants. The roof trusses are made using aluminium lattice beams. Special roof supports ensure a secure connection to the support scaffolding. PVC roof tarpaulins with weatherstrip on both sides can be inserted without problem into the top chords of the lattice beams and thus form the roof covering.

Technical data

- Double-pitch roof 18° (roof angle 20° on request) with tie or without tie*
- Mono-pitch roof (roof angle 15°- 20°)
- Barrel roof
- Spans up to about 38.0 m
- Bay widths up to 2.57 m
- Support scaffolding: SpeedyScaf 0.73 / 1.09 m, Allround 0.73 / 1.09 m or STAR 0.73 / 1.09 m

WARNING

Wind and snow loads are in accordance with regional regulations and must be complied with!

Truss composition and tarpaulins

Double-pitch roof 18°

Roof width [m]	Eaves section	Ridge section	Lattice beam 2.0 m	Lattice beam 3.0 m	Keder tarpaulin [m]	Gable tarpaulin [m]
5.90	2	1	0	0	10.50	5.80
9.70	2	1	2	0	14.50	9.60
11.60	2	1	0	2	16.50	11.50
13.50	2	1	4	0	18.50	13.40
15.40	2	1	2	2	20.50	15.30
17.30	2	1	0	4	22.50	17.20
19.20	2	1	4	2	24.50	19.10
21.10	2	1	2	4	26.50	21.00
23.00	2	1	0	6	28.50	22.90
24.90	2	1	4	4	30.50	24.80
26.80	2	1	2	6	32.50	26.70
28.70	2	1	0	8	34.50	28.60
30.60	2	1	4	6	36.50	30.50
32.50	2	1	2	8	38.50	32.40

Mono-pitch roof 18°

Roof width [m]	Truss outer dimension [m]	Eaves section	Lattice beams 2.0 m	Lattice beam 3.0 m	Mono-pitch roof beam	Roof tarpaulin [m]
4.81	5.06	2	0	0	1	11.00
6.71	7.06	2	1	0	1	11.00
7.66	8.06	2	0	1	1	14.00
8.61	9.06	2	2	0	1	14.00
9.57	10.06	2	1	1	1	14.00
10.52	11.06	2	0	2	1	17.00
11.47	12.06	2	2	1	1	17.00
12.42	13.06	2	1	2	1	17.00
13.37	14.06	2	0	3	1	20.00
14.32	15.06	2	2	2	1	20.00
15.27	16.06	2	1	3	1	20.00
16.22	17.06	2	0	4	1	22.50
17.17	18.06	2	2	3	1	22.50
18.13	19.06	2	1	4	1	24.50
19.08	20.06	2	0	5	1	24.50
20.03	21.06	2	2	4	1	26.50
20.98	22.06	2	1	5	1	26.50
21.93	23.06	2	0	6	1	28.50

* Fitting of a tie increases the snow load! For definition see page 23

3. MEASURES TO PREVENT FALLS

In line with local regulations or as the result of a risk analysis, fall prevention measures are necessary when assembling the Keder Roof XL.

Attachment points for personal safety apparatus (PSA)

If the use of personal safety apparatus (PSA) is required for assembling and dismantling the Keder Roof XL, the bottom chords of the roof beams must be used as attachment points (Fig. 3).

The suitability of PSA for preventing falls must be checked for the specific application. Particular attention must be paid here to the minimum fall heights (clear height underneath the user) as stated in the manufacturer's specifications for the connectors.

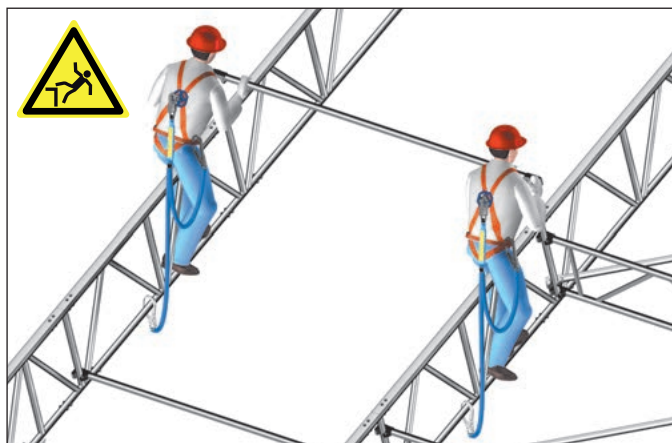

Fig. 3

4. ASSEMBLY

Assembly of the support scaffolding

Layher SpeedyScaf, Allround or STAR equipment with the axis dimensions 0.73 or 1.09 m can be used as the support scaffolding for the Layher Keder Roof XL. The scaffolding must be assembled in accordance with the appropriate instructions for assembly and use. The stability of the overall structure must be verified. The support scaffolding must be secured with locking pins, then ballasted and/or anchored to comply with structural strength requirements.

Preventing falls during assembly and dismantling of the support scaffolding

In line with local regulations or as the result of a risk analysis performed by the scaffolding erector, either personal safety apparatus (PSA) or an advance guard rail may be necessary for assembly and dismantling of the support scaffolding (see instructions for assembly and use of Layher SpeedyScaf/Layher Allround scaffolding).

For later assembly of the roof trusses, the top scaffolding level must be provided with side protection. This can be done preferably by attaching bracket levels about 1.0 m below the top deck level (Fig. 4) or by attachment of 1.0 m high frames or standards and fitting of upper guard rails and knee rails.

Assembly of supports and roof trusses

First position the roof supports (5975.073 / 109) on the support scaffolding, conforming to the scaffolding width, then secure them with locking pins (4000.001) (Fig. 4).

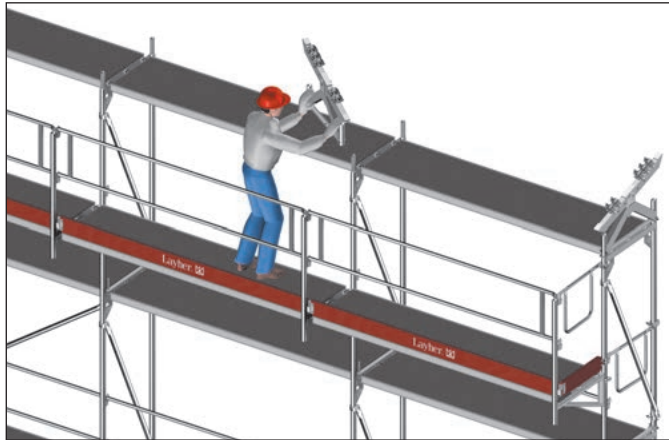
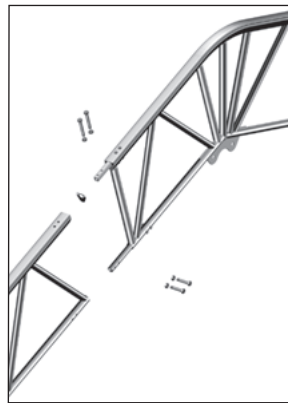

Fig. 4

Pre-assemble the lattice girders (5975.200 / 300), eaves sections (5975.100) and ridge sections (5975.110 / 120) on the ground to make trusses. At every joint of the top chord, insert a seal (5971.001) before putting the trusses together (Fig. 5). The trusses put together must then be firmly connected using two M12 x 60 mm special bolts and nuts (4095.060) or optionally tube securing pins (4905.666) to the bottom chord and using two M12 x 90 mm hexagon bolts and nut (5975.090) or optionally pins (5976.090) with locking pins (4905.000) to the top chord.



WARNING

As a general principle, two M12 bolts or two dia. 12 m pins must be fitted on each spigot side.

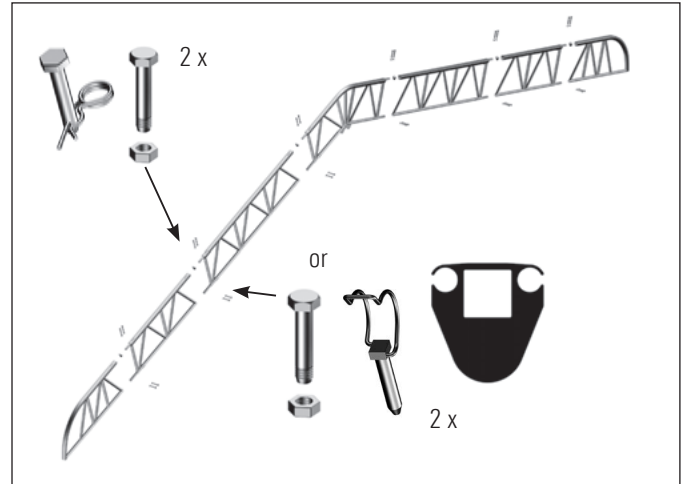

Fig. 5

WARNING

Missing bolts or pins reduce the stress capacity of the chords and can lead to collapse of the roof.

It must be noted that for the bracing variants "Light", "Standard" and "Heavy" **without tie chord**, only two couplers must be tightened in each case on the roof support. For a construction with **tie chord** the values shown in Tables 2, 3 and 4 on pages 25 – 29 apply. Couplers are tightened as shown in Table 1 (tightening torque 50 Nm).

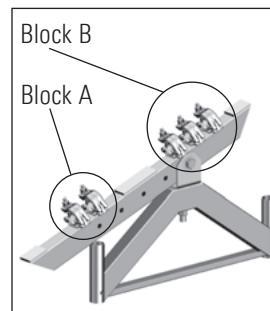

Fig. 6

Coupler connections (acc. to tables 2, 3 and 4)	Block	
	A	B
2	1	1
3	1	2
3	2	1
4	2	2
5	2	3

Table 1

Assembly of bracing elements

As a general principle, all bracing elements are fastened only to the truss posts, and horizontal diagonal braces always in the bottom chord level.

In the area of the eaves, a ledger (5972.257) must be fitted to the bottom chord. The first brace (5940.257) must be fitted to the first bottom truss post of the eaves section in such a way that it is slid up against the bottom chord (Fig. 7).

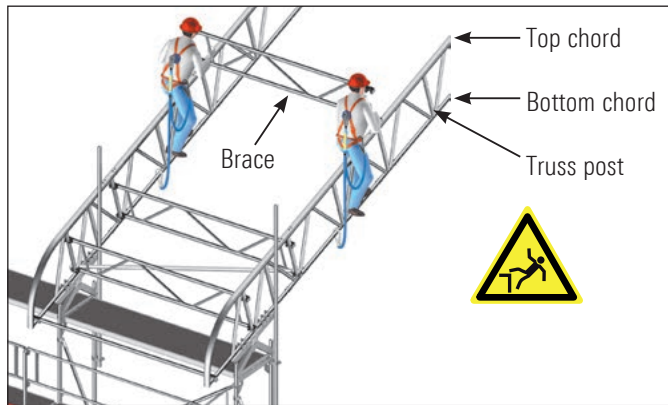

Fig. 7

The following braces are attached, depending on the bracing variant, with a spacing of 1.0 m or 2.0 m. Parallel to assembly of the braces, the diagonals of the horizontal brace are fitted at the bottom chord level.

As a general principle, a brace must always be fitted in the bracing bay, end bay or truss bay at the first truss post of the eaves section and at the last-but-one truss post of the ridge section.

The ledgers and diagonal braces are equalized on the eaves side.

For continuation see bracing variants "Light", "Standard" and "Heavy" on page 11

A maximum of four further bays without horizontal bracing can be suspended from a bracing bay (in the version with tie it is recommended that a horizontal bracing be provided in every 2nd bay). They must be followed by a bay with horizontal bracing, with every end bay also being constructed as a bay with horizontal bracing. Care must be taken that the snap-on claws are always pointing in the "eaves section" direction.

Definitions of roof bays:

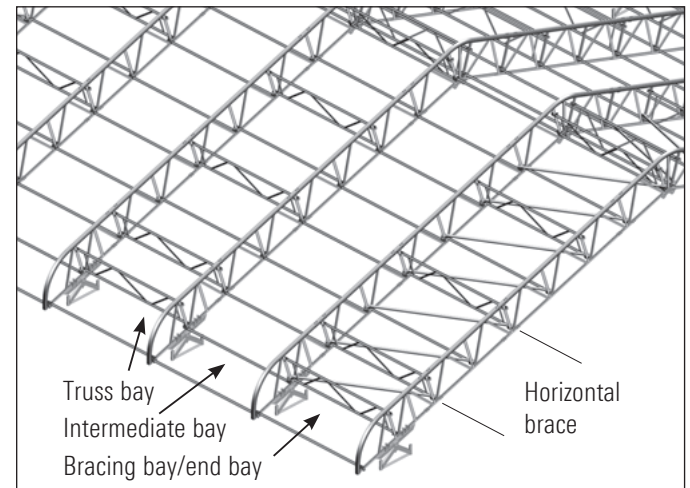

Exceptions:

At the last-but-one truss post of the ridge section, the snap-on claws always point in the direction of the ridge.

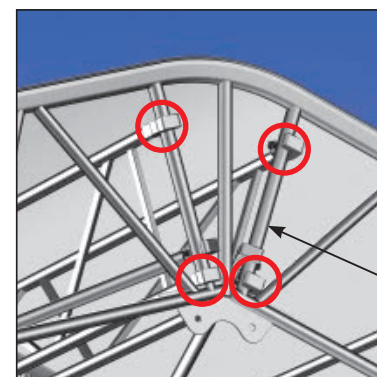

In the "Heavy" bracing variant, all snap-on claws must point in the direction of the ridge in the horizontal bracing bay!

In the intermediate bay, a ledger (5972.257) is attached at the bottom chord level, as an extension of the brace/ledger to the bracing or end bay, to the cross-strut of the truss (Fig. 8). Each truss bay must be fitted with braces (5940.257) in the same way as the bracing bay or end bay.

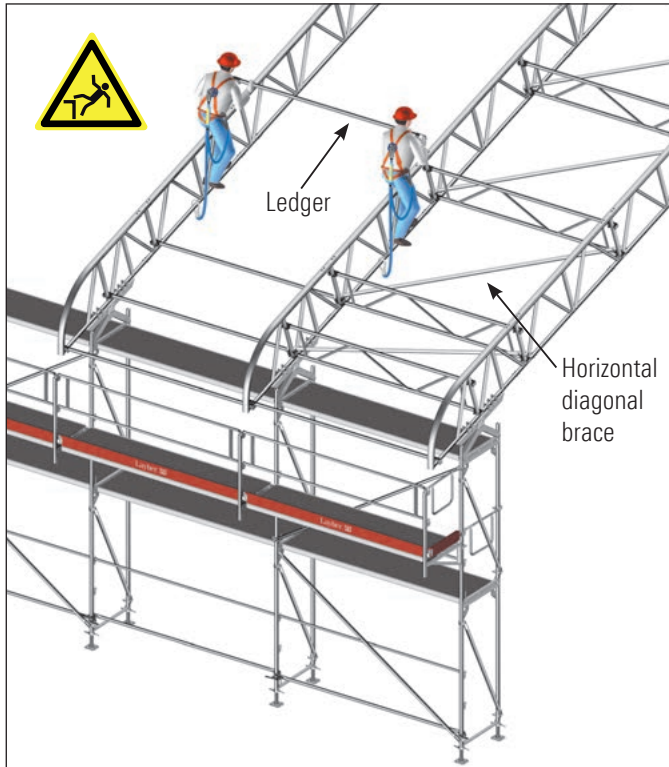

Fig. 8

The bracketed article numbers relate to a bay length of 2.57 m.

⚠ WARNING

Snap-on claws must fully engage, as poor connections reduce the stability.

Bracing variants

“Light” variant:

Braces are fitted every 2.0 m, seen from the ridge. In the last horizontal brace before the ridge, no 2.0 m diagonals can be installed; they are replaced by a ledger (5972.257) and two 1.0 m diagonals (5939.100) each fitted to the bottom chord. The following 2.0 m diagonals (5939.200) are fastened to the truss posts above the snap-on claw of the brace at the bottom chord. This procedure is repeated until the opposite eaves side is reached. If no 2.0 m diagonal can be installed in the last horizontal brace on the eaves side, it must be replaced by a 1.0 m diagonal (5939.100).

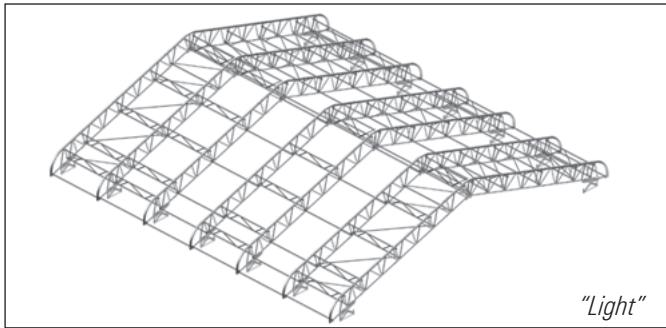

WARNING

Missing stiffening bays reduce the stability and can lead to collapse of the roof.

“Standard” variant:

Braces are fitted every 2.0 m, seen from the ridge. A ledger (5972.257) is fitted between them in such a way that it is pushed up against the bottom chord. Then the 1.0 m diagonals (5939.100) are fitted between brace and ledger. This operation is repeated as far as the eaves side until the bracing bay is completely assembled. The procedure is similar on the opposite side.

WARNING

Missing stiffening bays reduce the stability and can lead to collapse of the roof.

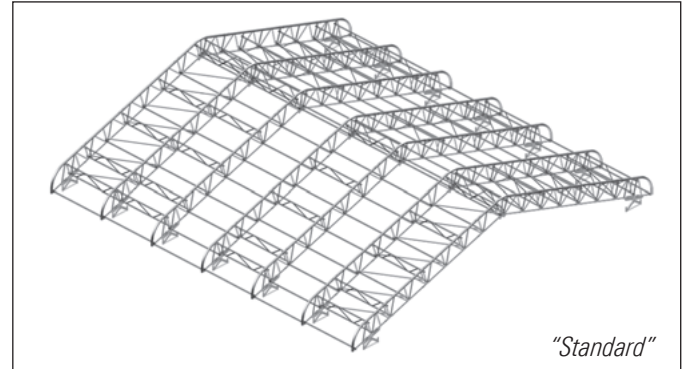

“Heavy” variant:

Braces are fitted every 1.0 m, seen from the ridge. In this case, all snap-on claws in the truss, bracing and end bays must point in the direction of the ridge! Once the first two braces have been fitted, the first diagonal (5939.100) is fastened between the braces above the snap-on claws at the bottom chord. This operation is repeated as far as the ridge until the bracing bay is completely assembled. The procedure is similar on the opposite side.

Remarks: If a truss bay is fitted in front of the bracing bay, two ledgers must be fitted to the ridge section instead of a brace.

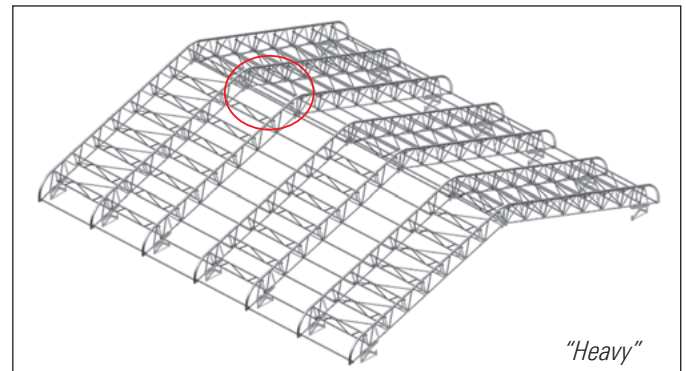

WARNING

Missing stiffening bays reduce the stability and can lead to collapse of the roof.

Crane assembly – Variant 1

The pre-assembled trusses are lifted by a crane onto the support scaffolding and placed into the half-couplers of the supports (Fig. 9). The trusses are firmly bolted to the support.

Tie

The tie, if required, is fitted before uprighting the pre-assembled trusses (see “Assembly of tie”, page 20). Once all trusses have been positioned on the support scaffolding and braced, the tie is tensioned.

Crane gear attachment points of the pre-assembled trusses:

The crane gear must be fastened to the top chord behind a truss post (Fig. 10).

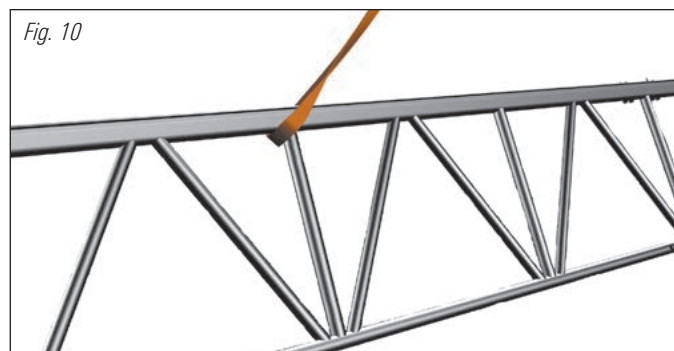

For positions of attachment points see Fig. 10-1. If necessary use additional loops made of polyester belt or wire rope!

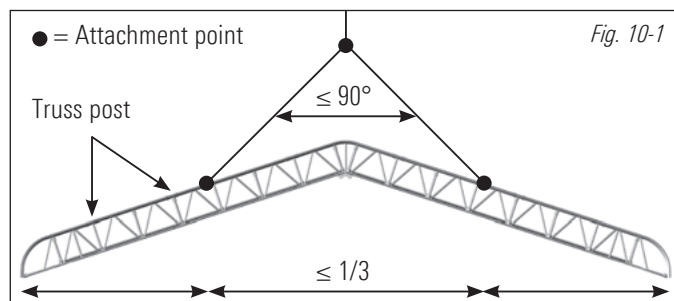

The weights of the individual trusses are given on page 22.

Caution: The specifications and the directions for use of the attachment equipment manufacturer, plus the relevant regulations of the professional associations, must be followed without fail!

Caution: Safeguard the truss against tilting sideways during assembly! To do so, a scaffolding tube can run up the outer frame, to which the truss is then attached using ropes (Fig. 9).

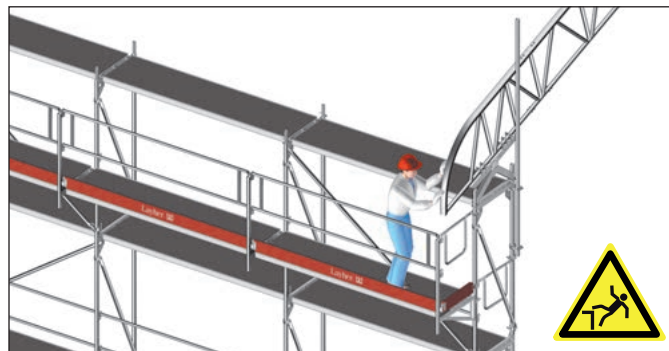

Fig. 9

⚠ WARNING

Missing securing tubes can lead to tipping over of the roof truss.

For removal of the crane gear from the 1st truss, an auxiliary tower (e.g. an original Layher tower system) should preferably be used. On no account climb onto the unbraced truss!

Once the first truss has been assembled, repeat the procedure for the second one. When this too has been firmly bolted to the roof supports and secured against tilting, stiffening the first truss bay must be started (see “Assembly of bracing elements”, page 9 and “Bracing variants”, page 11).

Crane assembly – Variant 2

Alternatively to assembly of individual trusses, it is possible to pre-assemble truss bays, bracing bays and end bays complete on the ground and to position them with a crane on the support scaffolding. The weights of the roof bays are given on page 22.

Caution: The specifications and the directions for use of the attachment equipment manufacturer, plus the relevant regulations of the professional associations, must be followed without fail!

Bracing

The first two uprighted trusses must be connected to one another as described on page 9, section “Assembly of bracing elements” in the appropriate bracing variant (page 11). Bracing, end and truss bays may only be uprighted with a crane!

Truss bays without horizontal brace must be additionally braced with diagonals, at least from the eaves to the attachment point of the crane gear, at the bottom chord of the lattice beams.

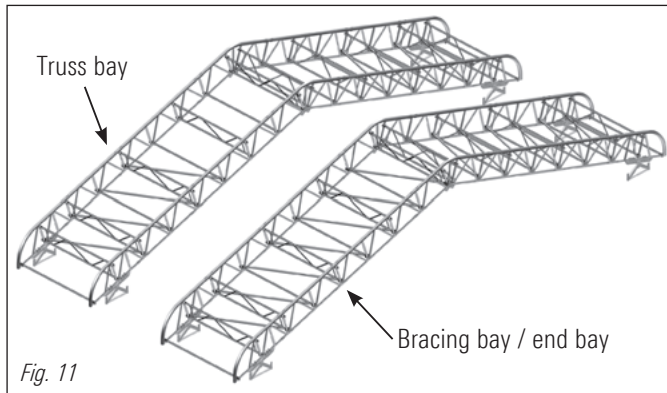

Tie

The tie, if required, is fitted before uprighting the pre-assembled roof bays (see “Assembly of tie”, page 20). Once all truss bays have been positioned on the support scaffolding and braced, the tie is tensioned.

Uprighting the pre-assembled truss bays

Completed roof bays are now lifted using a suitable crane onto every second scaffolding bay. To increase safety for the erectors, a bracket level with side protection must be fastened to the support scaffolding about 1 m below the roof supports. Couplers of the roof supports must be tightened at the trusses in accordance with Table 1.

Attachment points for four-part rope or chain gear

For positions of attachment points see Fig. 12. If necessary use additional loops made of polyester belt or wire rope!

Crane gear attachment points of the pre-assembled truss bays:

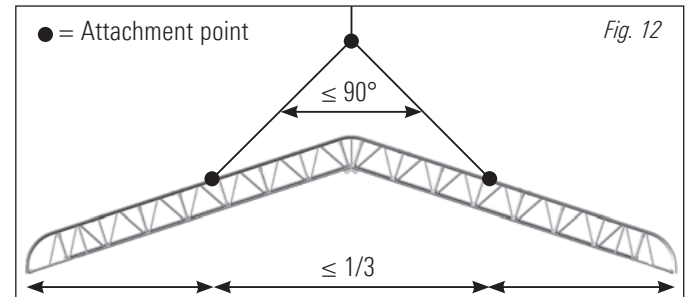

The crane gear must be fastened to the top chord behind a truss post.

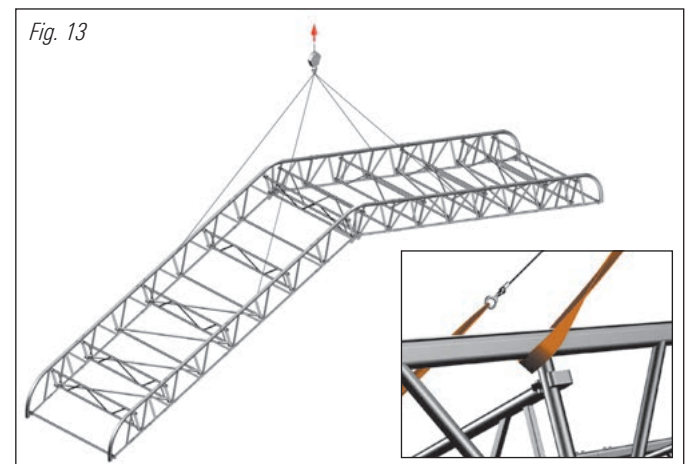

The support scaffolding must be built fully in accordance with structural strength requirements and with the valid regulations (see page 7). While swivelling the roof bay onto the free-standing support scaffolding, the erectors must be standing on a scaffolding level provided with side protection on both sides, or be wearing rope safety gear!

The roof bays are placed onto the support scaffolding with a crane and suitable lifting gear.

The roof bays must be positioned as they are being set down. To do so, an erector is ready on each side of the support scaffolding. A rope permits rotation of the roof bay from the deck (Fig. 14).

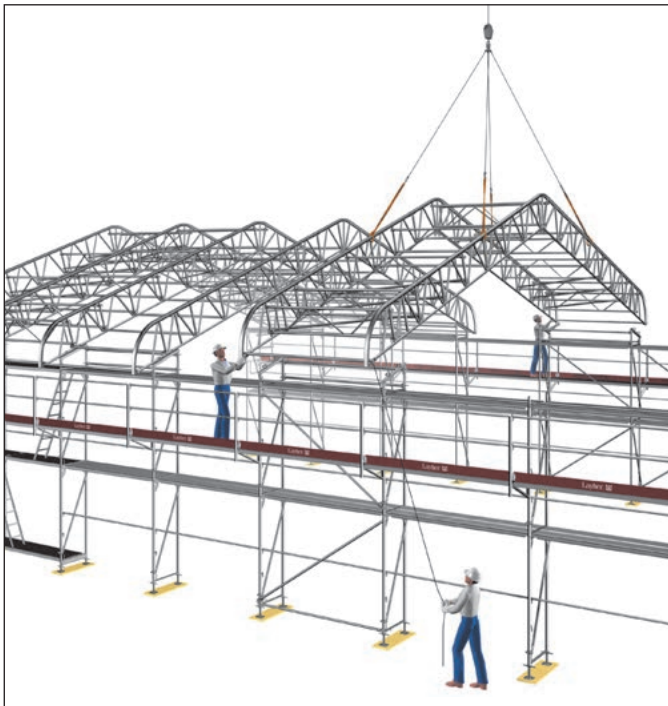

Fig. 14

Bracing of intermediate bays

The bracing elements of the intermediate bays are assembled as described above (page 9).

Assembly of a mobile roof – Variant 3

The Keder Roof XL can be made mobile using a small number of additional components. This makes it even more versatile in use. Furthermore, there is no need to climb onto the trusses during assembly. All bracing elements are fitted preferably on gable scaffolding (auxiliary tower), (see Fig. 15).

The permissible load on the system made up of roof support – trolley-adaptor for rail is $\pm 15.7 \text{ kN}$ ($= F_k$) with a rail span of 2.57 m. Please remember that not all maximum support loads (A_d) listed in the Tables 2 – 4 can be withstood by this system.

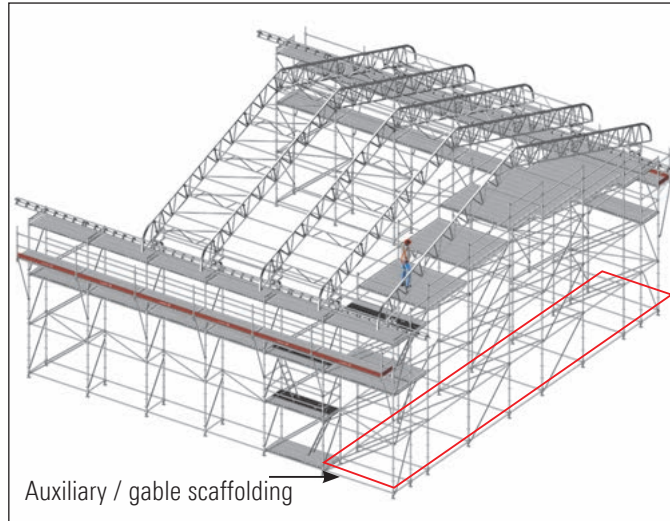

Fig. 15

The roof is moved section by section as building work progresses. This allows material to be saved. The roof is assembled from auxiliary scaffolding at a readily accessible position at one gable end of the area to be roofed over. The roof bays are put together and then gradually pushed along, away from the point of assembly. Openings larger than the bay width of 2.57 m can be achieved by pushing the roof apart.

Note: Since it is both difficult and time-consuming to align the two rails to be perfectly parallel over a great distance, the trolleys are designed to permit a certain amount of horizontal equalization in the transverse direction during movement of the roof. This ensures easily movability.

Assembly of gable scaffolding

The gable scaffolding must be assembled in accordance with the appropriate assembly and use instructions. The stability of the overall structure must be verified.

The support scaffolding is extended at the end by a further bay, of 3.07 m x 1.09 m or 0.73 m (Fig. 16).

The gable scaffolding is preferably designed as a 3.07 m x 2.57 m bay with the inner nominal width (N_i) of the support scaffolding being adjusted accordingly. At the top level, 2.57 m double ledgers must be fitted for the decks. To equalize the 18° angle of the trusses, it is recommended at the level of the support scaffolding to continue with a rise of the gable scaffolding by individual bays in 0.5 m steps.

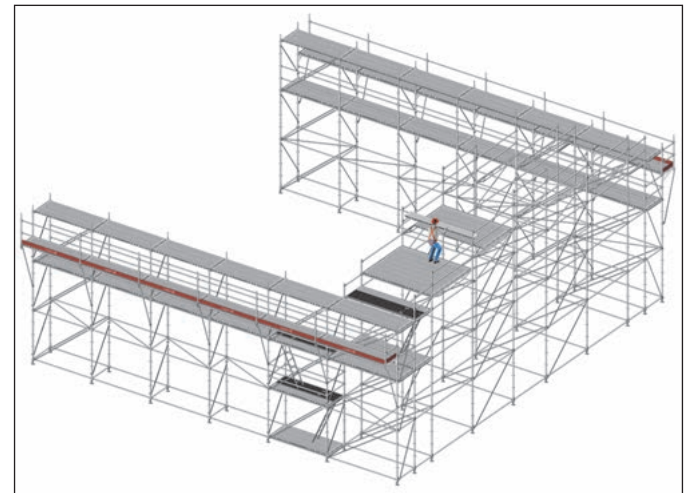

Fig. 16

Assembly of rails

The 3.0 m rails must reach at least to the outer edge of the gable scaffolding / auxiliary scaffolding and past the support scaffolding.

The adapters (A) for the rail are fitted onto the support scaffolding and secured with locking pins (B). The rail (C) is centered on the adapter sections and fastened to the bottom chords with two double couplers (D) (Fig. 17).

Remarks:

Care must be taken that the tube with the welded-in centering pin is the top chord of the rail on which the trolley travels. In the case of fitting on an Allround 0.73 m support scaffolding, the use of adapters (A) can be dispensed with, and the rail can be fastened directly to the ledgers.

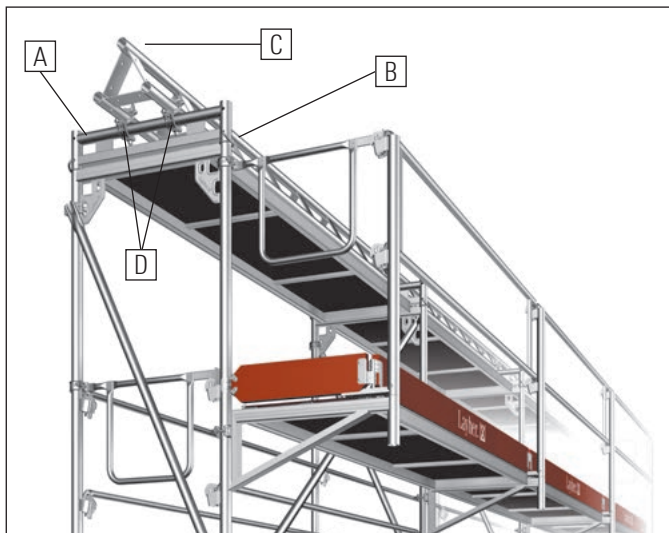

Fig. 17

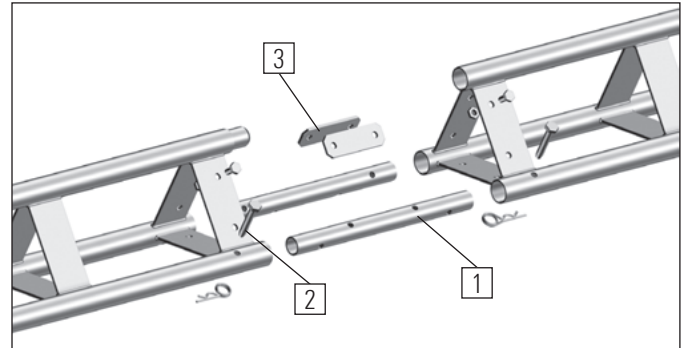

Fig. 18

The rails are connected to one another with two spigots (1) and four pins (2) at the bottom chord, and by two plates (3) with four bolts at the top chord (see Fig. 18).

WARNING

At the ends of the rails, couplers must be fastened to the top chord as stoppers for the trolley to prevent the latter overshooting the end of the rail.

Assembly of trolley

To place the trolley on the rail, the WAF 19 bolts (N) must be slightly loosened, or the trolley can be “threaded in” at the end of the rail. After positioning, the bolts (N) must be retightened. The clear dimension (M) must be set using the nuts (O) and a WAF 19 spanner in such a way that the connecting plates of the rail can just be passed over. The clear dimension (M) must be as low as possible to ensure the maximum load capacity of the lift-off preventer (Fig. 19).

⚠ WARNING

If the clear dimension M is not set as low as possible, the maximum load capacity of the lift-off preventer is not attained. That means the roof might lift off even under fairly low loads!

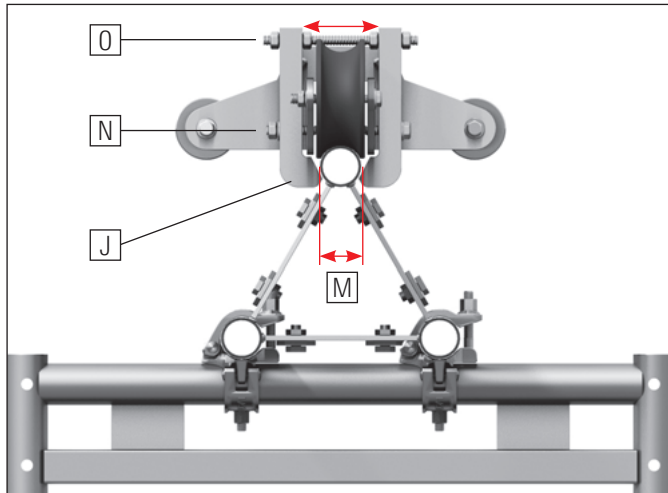

Fig. 19

Assembly of roof supports

The roof supports (E) are connected as shown in Fig. 20 to form a unit by fitting 2.57 m O-ledgers (F), and then placed onto the trolley (G). After that the roof supports are secured against lift-off using the supplied pins (H, Fig. 21).

For mounting the roof on the trolley, the latter must be stabilized by bracing it on the support scaffolding with the aid of tubes and coupler.

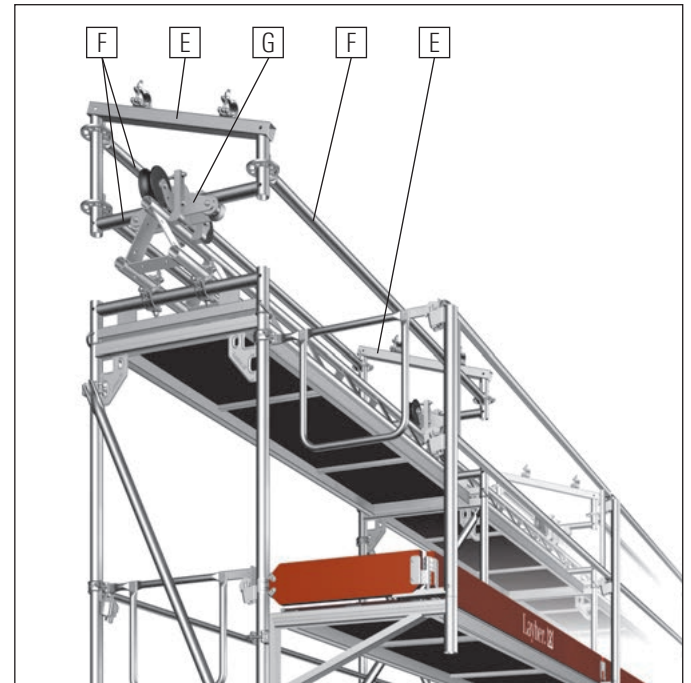

Fig. 20

To safeguard against shifting, double couplers (K) must be installed on the top chord of the rail on the right and left of the trolley. To prevent movement in the transverse direction, couplers (L) must also be installed at one side of the roof at the tube of the roof support. To move the roof, the securing couplers (K) on the top chord of the rail must be removed. The couplers (L) on the one side of the roof remain fitted (Fig. 21).

The permanent lift-off preventers (J) also safeguard against lift-off during movement.

WARNING

The roof must be immediately secured against further movement once the intended movement has been completed. Missing lift-off and movement preventers can lead to collapse of the roof!

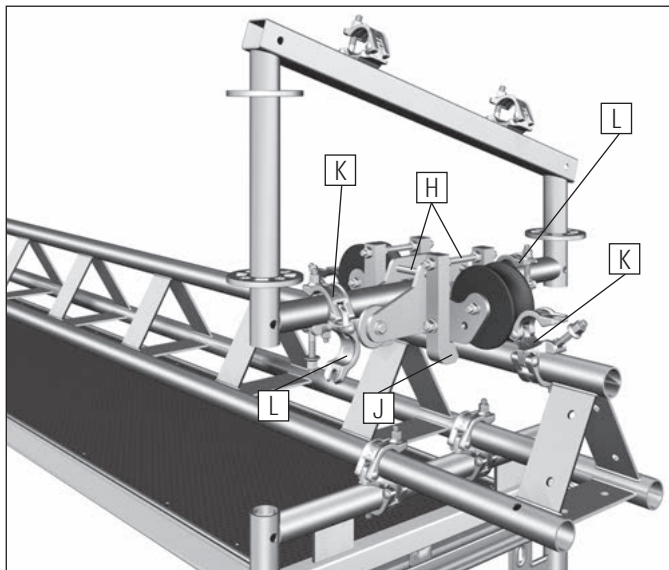

Fig. 21

WARNING

It is not permitted to mount the flexible roof support (5975.073/109) on the trolley! This is because forces are generated here that can cause the roof to collapse!



Fig. 22

Assembly of roof trusses

The tie, if required, is fitted before uprighting of the pre-assembled trusses or roof bays (see "Assembly of tie", page 20). Once all trusses or bays have been positioned on the support scaffolding and braced, the tie is tensioned.

Once the gable scaffolding and the two rails have been completely assembled, the first truss is placed on the support, bolted and secured against tilting. The procedure is similar for the second truss. Once both trusses have been fitted using the gable scaffolding and secured, a start can be made on bracing the trusses appropriately from the gable scaffolding (see "Assembly of bracing elements", page 9 and "Bracing variants", page 11).

Then the braced bay is slid rearwards over the support scaffolding (Fig. 23), and the third truss can be positioned and connected to the already assembled roof bay using the gable scaffolding (Fig. 24).

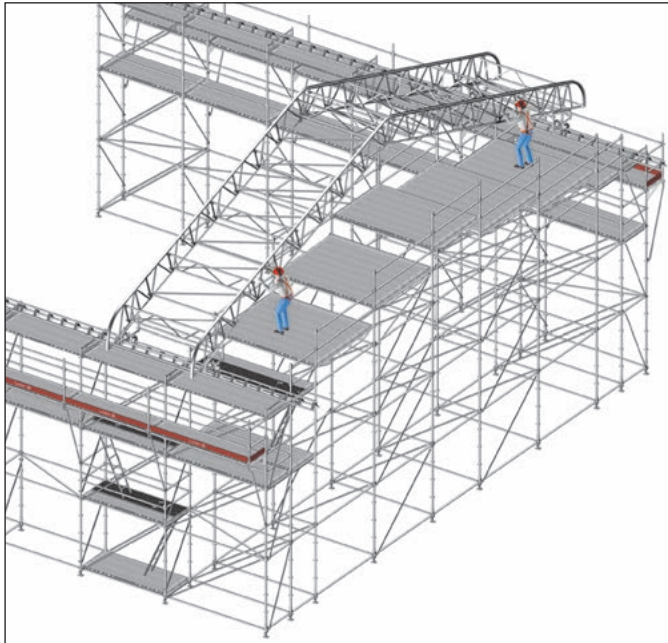

Fig. 23

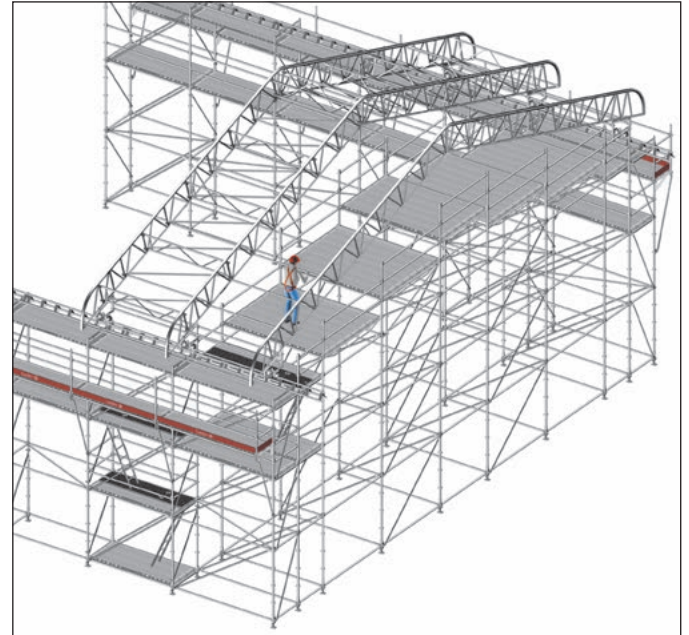

Fig. 24

It is also possible, as described on pages 13 and 14, to place entire roof bays onto the gable scaffolding.

5. ASSEMBLY OF TIE

Assembly of a tie using the example of Keder Roof XL , "Heavy" variant

The tie connection pieces "tension strap (5975.010)" and "threaded rod (5975.020)" are fastened to the roof support before assembly of the trusses or roof bays. They are fitted to the pin of the support beam. Subsequent attachment is only possible with the structurally less favourable tie fastening (5975.000).

The first tie rod 2.0 / 3.0 / 4.0 / 5.0 m (5976.200 / 300 / 400 / 500) is screwed into the tie connection "threaded rod". To obtain the required overall length, the tie rods must be connected to one another by rod connectors (5976.000). The tie rods must be screwed into the rod connector as far as they will go. The tie connection piece (5975.030) is fastened to its end. The lashing strap (5976.600) is now fitted between the tie connection "tension strap" and the tie connection piece, and the distance of 1.0 m with a single belt strap must not be exceeded, whereas a distance of 2.0 m is possible with double winding. The permissible tension force (working load) of the lashing strap (5976.600) must be at least 5 t!

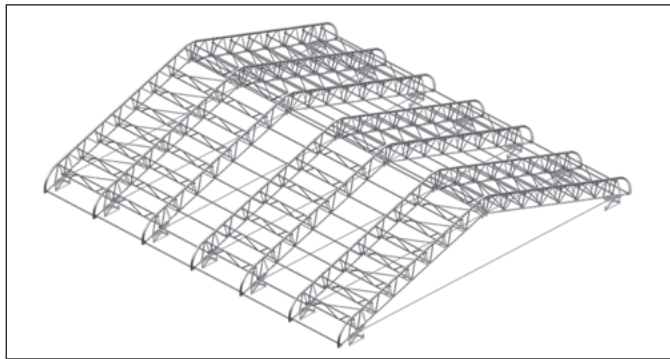

Fig. 25

WARNING

Missing ties reduce the load-bearing capacity and can lead to collapse of the roof.

Fitting on roof support*:

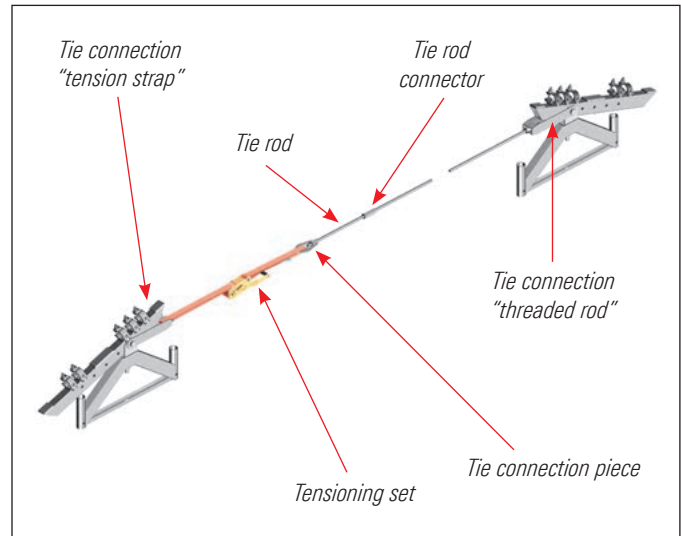

Fig. 26

* structurally preferable

Fitting on roof truss**:

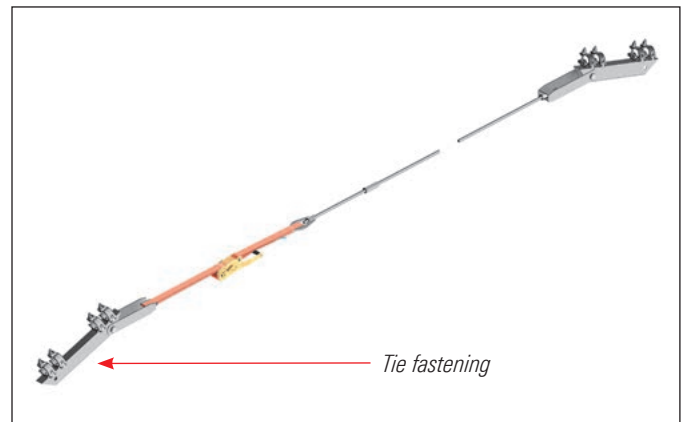

Fig. 27

** for subsequent installation of a tie

6. FITTING OF TARPAULINS

Fitting of gable tarpaulins

To close the roof on the gable side, it is possible to attach gable tarpaulins. These tarpaulins are, depending on the spans, in two or four parts, and must be pulled, starting from the eaves section, into the outer Keder groove of the eaves truss (Fig. 28). Once the tarpaulin sections have been pulled in, connect them vertically using the velcro strips provided (Fig. 29). A horizontal eyelet strip on each gable tarpaulin allows wall tarpaulins to be attached.



Fig. 28



Fig. 29

Fitting of roof tarpaulins

The roof tarpaulin must be positioned centered in front of the truss bay, and the tarpaulin insertion set (5971.400) must be pulled through the hollow border of the tarpaulin. Lay the ropes fastened to the set over the roof, position the tarpaulin at the Keder grooves and then insert it parallel (Fig. 30). The rollers of the set run on the top chord of the lattice beam. Now pull the tarpaulin using the ropes, evenly from the opposite eaves through the entire truss (Fig. 33). To prevent it skewing, it is recommended that the tarpaulin be guided into the Keder groove at the starting side.

Tip: Easy movement is aided by silicone oil or simple detergent.

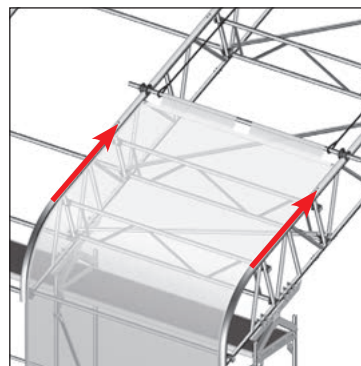

Fig. 30

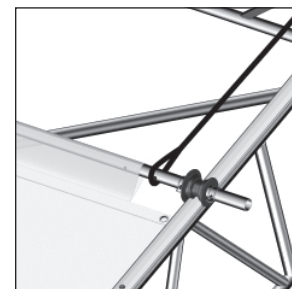

Fig. 30 Detail

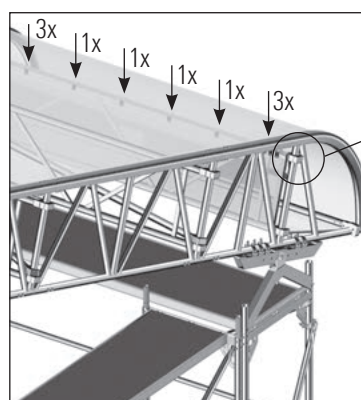

Fig. 31

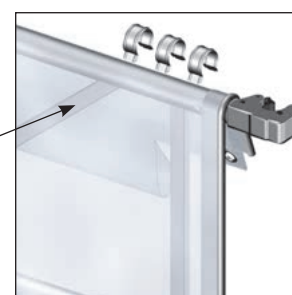

Fig. 32

Once the roof tarpaulin has been pulled over the opposite eaves and centered over the truss length, secure it using three tarpaulin clips (5971.140) at the edges of the roof bays (Figs. 31 and 32). In the central bay area, single tarpaulin clips spaced 30–40 cm apart are sufficient.

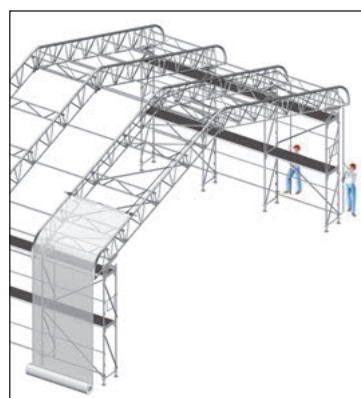
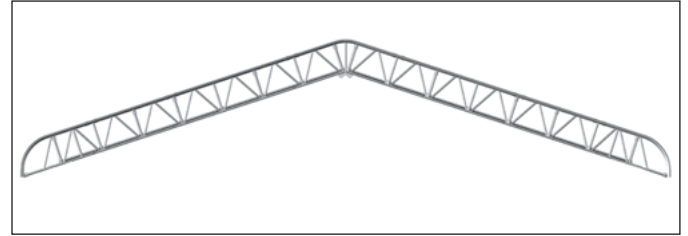

Fig. 33

7. WEIGHTS OF PRE-ASSEMBLED TRUSSES AND TRUSS BAYS

	Roof width [m]	Truss [kg]	Truss bay [kg]
Double-pitch roof 18°	5.90	53.90	193.00
	9.70	89.30	320.60
	11.60	103.50	354.20
	13.50	124.70	413.30
	15.40	138.90	470.10
	17.30	153.10	515.30
	19.20	174.30	586.10
	21.10	188.50	631.30
	23.00	202.70	688.10
	24.90	223.80	747.20
	26.80	238.00	804.00
	28.70	252.20	849.20
	30.60	273.40	919.30
32.50	287.60	965.20	
Mono-pitch roof 18°	4.81	58.60	178.10
	6.71	61.60	212.50
	7.66	68.70	240.90
	8.61	79.30	276.30
	9.57	86.40	304.70
	10.52	93.50	333.10
	11.47	104.10	368.50
	12.42	111.20	396.90
	13.37	118.30	425.30
	14.32	128.80	460.70
	15.27	195.90	489.00
	16.22	143.00	517.50
	17.17	153.60	552.90
	18.13	160.70	581.30
	19.08	167.80	609.70
	20.03	178.40	645.00
	20.98	185.50	673.40
21.93	192.60	701.80	

With regard to a possible assembly of the roof with the aid of a crane, the following lists the weights of the pre-assembled trusses and truss bays. The weights stated for the truss bays are maximum weights each representing a braced end bay in the "Heavy" bracing variant.



Example: Truss

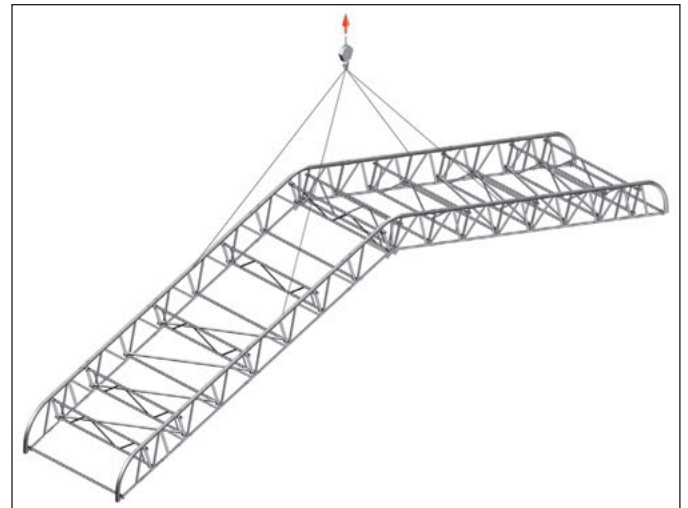

Example: Truss bay

8. SPANS AND LOADS

For 1-bay double-pitch and mono-pitch roof designs with 18° roof angle, the stress capacities \bar{s}_d and \bar{w}_d of the roof trusses were determined for the load combinations “maximum snow” and “maximum wind suction” respectively. The snow and wind suction loads were assumed here to be constant line loads in accordance with the sketches presented in the load tables. Other snow and wind load assumptions are not taken into account in the calculations. From the determined linear stress capacities \bar{s}_d and \bar{w}_d , further quantities are then derived, for example the characteristic snow or wind suction load. In the transition from the characteristic wind suction load w_c to the dynamic pressure q_{eff} , a c_{pe} value of -0.6 was assumed for the double-pitch roof and of -0.9 for the mono-pitch roof. A gauge pressure acting from within and a reduction as a result of the service life are not taken into account.

In the calculations, the roof trusses were modelled as lattices, recording among other things heat-influenced areas, welds, net cross-sections, local bending moments, precambers in and out of the lattice plane, and stresses from impacts. The calculations were based on second order theory at the design load level, without account being taken of the support scaffolding structure.

Key to table columns:

Roof width B [m]:	see Figs. on page 24
Span L [m]	see Figs. on page 24
Bracing variant:	see page 11
max \bar{g}_c [kN/m]:	maximum dead weight of the roof structure, based on a roof truss
min \bar{g}_c [kN/m]:	minimum dead weight of the roof structure, based on a roof truss
Number of couplers for roof support:	see Fig. 6 and Table 1
max \bar{s}_d [kN/m]:	design value of maximum snow load, based on a roof truss
max \bar{s}_d [kN/m ²]:	characteristic value of maximum snow load, based on the roof area
max A_d [kN]:	design value of maximum support force resulting from snow and maximum dead weight
max \bar{w}_d [kN/m]:	design value of maximum wind suction load, based on a roof truss
max w_c [kN/m ²]:	characteristic value of maximum wind suction load, based on the roof area
max q_{eff} [kN/m ²]:	the dynamic pressure associated with max w_c when assuming a c_p value of -0.6 / -0.9
max v_{eff} [m/s]:	the wind velocity associated with q_{eff}
min A_d [kN]:	design value of minimum support force resulting from wind suction and minimum dead weight

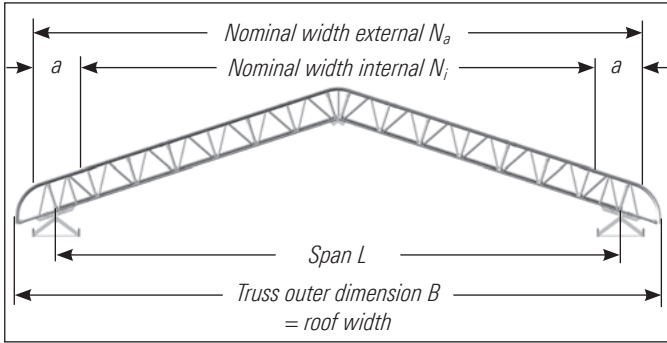

Nominal widths: $N_a = L + a$

$N_i = L - a$

a – axis dimension of frame 0.73 / 1.09 m

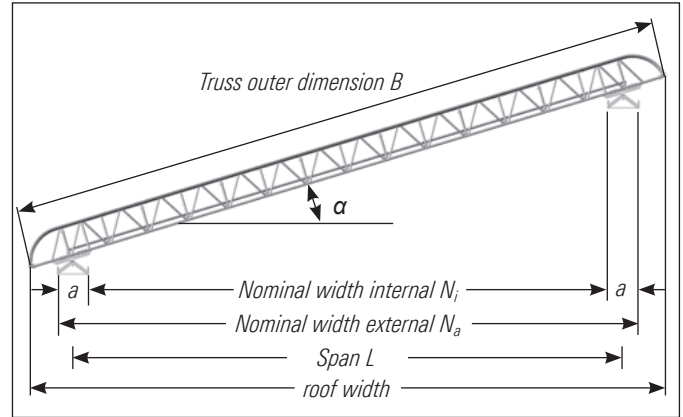

Nominal widths: $N_a = L \times \cos \alpha + a$

$N_i = L \times \cos \alpha - a$

a – axis dimension of frame 0.73 / 1.09 m

α – roof angle 15 – 20 degrees

**Keder Roof XL – load-bearing capacities
of double-pitch roof beam 18° without tie
(structurally determined mounting)**

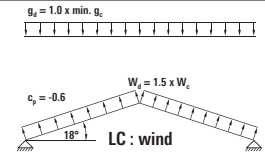
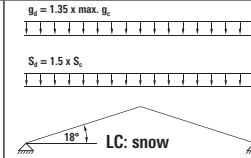

Truss distance b = 2.57 m							Maximum snow load			Maximum wind suction				
No.	Truss dimensions		Bracing variant	max. \bar{g}_c [kN/m]	min. \bar{g}_c [kN/m]	Number of couplers Roof support	max. \bar{s}_d [kN/m]	max. s_c [kN/m ²]	max. A_d [kN]	max. \bar{w}_d [kN/m]	max. w_e [kN/m ²]	max. Q_{eff} ($c_p = -0.6$) [kN/m ²]	max. v_{eff} [m/s]	min. A_d [kN]
	Roof width B [m]	Span L [m]												
1	11.60	9.60	Light	0.172	0.154	2	3.75	0.97	23.0	-1.68	-0.44	0.73	34.11	-8.8
			Standard	0.203	0.175		3.70	0.96	23.0	-5.42	-1.40	2.34	61.18	-30.3
			Heavy	0.227	0.196		4.74	1.23	29.1	-5.44	-1.41	2.35	61.31	-30.3
2	13.50	11.50	Light	0.172	0.154	2	2.50	0.65	18.3	-1.19	-0.31	0.51	28.67	-7.0
			Standard	0.203	0.175		2.45	0.64	18.3	-3.86	-1.00	1.67	51.65	-24.8
			Heavy	0.227	0.196		3.88	1.01	28.2	-3.89	-1.01	1.68	51.83	-24.8
3	15.40	13.40	Light	0.172	0.154	2	1.75	0.45	15.2	-0.91	-0.23	0.39	25.02	-5.8
			Standard	0.203	0.175		1.71	0.44	15.2	-2.85	-0.74	1.23	44.34	-20.5
			Heavy	0.227	0.196		2.76	0.72	23.5	-2.87	-0.74	1.24	44.52	-20.5
4	17.30	15.30	Light	0.172	0.154	2	1.28	0.33	13.1	-0.73	-0.19²	0.31	22.42	-4.9
			Standard	0.203	0.175		1.24	0.32	13.0	-2.20	-0.57	0.95	39.00	-17.5
			Heavy	0.227	0.196		2.01	0.52	20.0	-2.23	-0.58	0.96	39.23	-17.5
5	19.20	17.20	Light	0.172	0.154	2	0.96	0.25	11.4	-0.60	-0.16²	0.26	20.43	-4.3
			Standard	0.203	0.175		0.91	0.24	11.4	-1.77	-0.46	0.76	34.97	-15.3
			Heavy	0.227	0.196		1.52	0.39	17.5	-1.79	-0.47	0.78	35.21	-15.3
6	21.10	19.10	Light	0.172	0.154	2	0.73	0.19	10.1	-0.52	-0.14²	0.23	19.01	-3.9
			Standard	0.203	0.175		0.69	0.18	10.1	-1.47	-0.38	0.63	31.82	-13.6
			Heavy	0.227	0.196		1.16	0.30	15.4	-1.49	-0.39	0.64	32.09	-13.6
7	23.00	21.00	Light	0.172	0.154	2	0.56	0.15	9.1	-0.46	-0.12²	0.20	17.85	-3.5
			Standard	0.203	0.175		0.52	0.13	9.1	-1.24	-0.32	0.54	29.30	-12.2
			Heavy	0.227	0.196		0.91	0.23	13.9	-1.27	-0.33	0.55	29.60	-12.3
8	24.90	22.90	Light	0.172	0.154	2	0.44	0.11	8.3	-0.41	-0.11²	0.18	16.92	-3.2
			Standard	0.203	0.175		0.39	0.10	8.3	-1.08	-0.28	0.46	27.27	-11.2
			Heavy	0.227	0.196		0.71	0.18	12.6	-1.10	-0.29	0.48	27.57	-11.2
9	26.80	24.80	Light	0.172	0.154	2	0.34	0.09¹	7.6	-0.38	-0.10²	0.16	16.16	-3.0
			Standard	0.203	0.175		0.29	0.08¹	7.6	-0.95	-0.24	0.41	25.56	-10.3
			Heavy	0.227	0.196		0.56	0.14	11.5	-0.97	-0.25	0.42	25.89	-10.4
10	28.70	26.70	Light	0.172	0.154	2	0.26	0.07¹	7.0	-0.35	-0.09²	0.15	15.53	-2.8
			Standard	0.203	0.175		0.21	0.06¹	7.0	-0.84	-0.22	0.36	24.11	-9.5
			Heavy	0.227	0.196		0.44	0.11	10.6	-0.87	-0.22	0.37	24.48	-9.6
11	30.60	28.60	Light	0.172	0.154	2	0.19	0.05¹	6.5	-0.33	-0.08²	0.14	15.03	-2.6
			Standard	0.203	0.175		0.15	0.04¹	6.5	-0.76	-0.20²	0.33	22.89	-8.9
			Heavy	0.227	0.196		0.34	0.09¹	9.9	-0.78	-0.20²	0.34	23.28	-9.0

Table 2

**Keder Roof XL – load-bearing capacities
of double-pitch roof beam 18° with tie
(structurally determined mounting)**

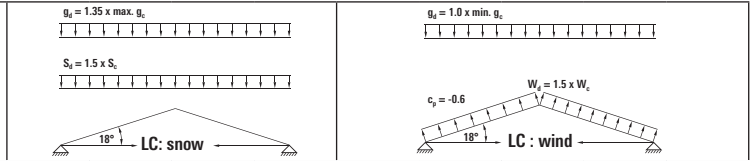

Truss distance b = 2.57 m							Maximum snow load				Maximum wind suction				
No.	Truss dimensions		Bracing variant	max. \bar{g}_e [kN/m]	min. \bar{g}_e [kN/m]	Number of couplers Roof support	max. \bar{s}_d [kN/m]	max. s_c [kN/m ²]	Tie max. Z_d [kN]	max. A_d [kN]	max. \bar{w}_d [kN/m]	max. w_c [kN/m ²]	max. q_{eff} ($c_p = -0.6$) [kN/m ²]	max. v_{eff} [m/s]	min. A_d [kN]
	Roof width B [m]	Span L [m]													
1	11.60	9.60	Light	0.172	0.154	2	5.11	1.33	19.93	30.9	-1.68	-0.44	0.73	34.11	-8.8
						3	6.41	1.66	24.86	38.4					
			Standard	0.203	0.175	3	6.37	1.65	24.86	38.4	-5.42	-1.40	2.34	61.18	-30.3
			Heavy	0.227	0.196	3	6.31	1.64	24.44	38.2	-5.44	-1.41	2.35	61.31	-30.3
2	13.50	11.50	Light	0.172	0.154	2	3.45	0.90	19.90	24.8	-1.19	-0.31	0.51	28.67	-7.0
						3	5.48	1.42	31.08	38.4					
			Standard	0.203	0.175	3	5.44	1.41	31.08	38.4	-3.86	-1.00	1.67	51.65	-24.8
			Heavy	0.227	0.196	3	5.57	1.44	31.61	39.5	-3.89	-1.01	1.68	51.83	-24.8
3	15.40	13.40	Light	0.172	0.154	2	2.52	0.65	19.82	21.1	-0.91	-0.23	0.39	25.02	-5.8
						3	4.46	1.16	34.08	36.0					
			Standard	0.203	0.175	3	4.41	1.14	34.08	36.0	-2.85	-0.74	1.23	44.34	-20.5
			Heavy	0.227	0.196	3	5.03	1.30	38.45	40.9	-2.87	-0.74	1.24	44.52	-20.5
4	17.30	15.30	Light	0.172	0.154	2	1.94	0.50	19.71	18.7	-0.73	-0.19²	0.31	22.42	-4.9
						3	3.72	0.97	36.32	34.1					
			Standard	0.203	0.175	3	3.68	0.95	36.32	34.1	-2.20	-0.57	0.95	39.00	-17.5
			Heavy	0.227	0.196	3	4.30	1.11	42.03	39.7	-2.23	-0.58	0.96	39.23	-17.5
4	4.57	1.18				44.51	42.0								
5	19.20	17.20	Light	0.172	0.154	2	1.56	0.40	19.65	17.1	-0.60	-0.16²	0.26	20.43	-4.3
						3	3.21	0.83	38.28	32.9					
			Standard	0.203	0.175	3	3.16	0.82	38.28	32.9	-1.77	-0.46	0.76	34.97	-15.3
			Heavy	0.227	0.196	3	3.48	0.90	41.91	36.3	-1.79	-0.47	0.78	35.21	-15.3
4	4.21	1.09				50.25	43.2								
6	21.10	19.10	Light	0.172	0.154	2	1.28	0.33	19.60	16.0	-0.52	-0.14²	0.23	19.01	-3.9
						3	2.77	0.72	39.39	31.6					
			Standard	0.203	0.175	3	2.73	0.71	39.39	31.6	-1.47	-0.38	0.63	31.82	-13.6
			Heavy	0.227	0.196	3	2.90	0.75	41.81	33.8	-1.49	-0.39	0.64	32.09	-13.6
4	3.89	1.01				55.15	44.1								
7	23.00	21.00	Light	0.172	0.154	2	1.08	0.28	19.52	15.1	-0.46	-0.12²	0.20	17.85	-3.5
						3	2.39	0.62	39.60	30.1					
			Standard	0.203	0.175	3	2.35	0.61	39.60	30.1	-1.24	-0.32	0.54	29.30	-12.2
			Heavy	0.227	0.196	3	2.41	0.62	41.73	31.1	-1.27	-0.33	0.55	29.60	-12.3
						4	3.45	0.89	57.01	43.1					
5	3.53	0.92				58.29	44.1								

Table 3-1

<p style="text-align: center;">Keder Roof XL – load-bearing capacities of double-pitch roof beam 18° with tie (structurally determined mounting)</p>															
							Truss distance b = 2.57 m			Maximum snow load				Maximum wind suction	
No.	Truss dimensions		Bracing variant	max. \bar{g}_c [kN/m]	min. \bar{g}_c [kN/m]	Number of couplers Roof support	max. \bar{s}_d [kN/m]	max. s_c [kN/m ²]	Tie max. Z_d [kN]	max. A_d [kN]	max. \bar{w}_d [kN/m]	max. w_c [kN/m ²]	max. q_{eff} ($c_p = -0.6$) [kN/m ²]	max. v_{eff} [m/s]	min. A_d [kN]
	Roof width B [m]	Span L [m]													
8	24.90	22.90	Light	0.172	0.154	2	0.93	0.24	19.50	14.4	-0.41	-0.11²	0.18	16.9	-3.2
						3	2.12	0.55	40.11	29.2					
			Standard	0.203	0.175	3	2.07	0.54	40.11	29.1	-1.08	-0.28	0.46	27.3	-11.2
						3	2.14	0.55	41.49	30.4	-1.10	-0.29	0.48	27.6	-11.2
						4	3.01	0.78	56.97	41.2					
Heavy	0.227	0.196	5	3.23	0.84	60.86	43.9								
			2	0.81	0.21	19.49	13.9	-0.38	-0.10²	0.16	16.2	-3.0			
Light	0.1720	0.154	3	1.87	0.48	40.06	28.1								
			Standard	0.203	0.175	3	1.82	0.47	40.06	28.0	-0.95	-0.24	0.41	25.6	-10.3
3	1.88	0.49				41.49	29.3	-0.97	-0.25	0.42	25.9	-10.4			
4	2.66	0.69				56.95	39.7								
Heavy	0.227	0.196	5	2.96	0.77	63.02	43.7								
			2	0.71	0.18	19.48	13.5	-0.35	-0.09²	0.15	15.5	-2.8			
Light	0.172	0.154	3	1.66	0.43	39.79	27.1								
			Standard	0.203	0.175	3	1.61	0.42	39.79	27.0	-0.84	-0.22	0.36	24.1	-9.5
3	1.67	0.43				41.49	28.4	-0.87	-0.22	0.37	24.5	-9.6			
4	2.38	0.62				56.93	38.5								
Heavy	0.227	0.196	5	2.73	0.71	64.81	43.5								
			2	0.63	0.16	19.47	13.1	-0.33	-0.08²	0.14	15.0	-2.6			
Light	0.172	0.154	3	1.48	0.38	39.50	26.2								
			Standard	0.203	0.175	3	1.44	0.37	39.50	26.2	-0.76	-0.20²	0.33	22.9	-8.9
3	1.50	0.39				41.50	27.6	-0.78	-0.20²	0.34	23.3	-9.0			
4	2.13	0.55				56.60	37.3								
Heavy	0.227	0.196	5	2.53	0.66	66.32	43.3								
			2	0.56	0.14	19.36	12.8	-0.31	-0.08²	0.13	14.6	-2.5			
Light	0.172	0.154	3	1.32	0.34	36.88	25.2								
			Standard	0.203	0.175	3	1.28	0.33	38.88	25.2	-0.69	-0.18²	0.30	21.9	-8.4
3	1.36	0.35				41.51	27.0	-0.72	-0.19²	0.31	22.2	-8.4			
4	1.94	0.50				56.68	36.5								
Heavy	0.227	0.196	5	2.35	0.61	67.59	43.1								

Table 3-1

**Keder Roof XL – load-bearing capacities
of mono-pitch roof with 18° roof angle
(structurally determined mounting)**

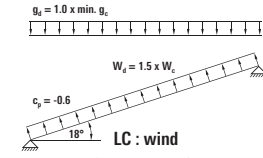
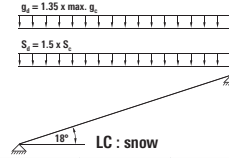

Truss distance b = 2.57 m							Maximum snow load			Maximum wind suction				
No.	Truss dimensions		Bracing variant	max. \bar{g}_c [kN/m]	min. \bar{g}_c [kN/m]	Number of couplers Roof support	max. \bar{s}_d [kN/m]	max. s_c [kN/m ²]	max. A_d [kN]	max. \bar{w}_d [kN/m]	max. w_c [kN/m ²]	max Q_{eff} ($c_p = -0.9$) [kN/m ²]	max. v_{eff} [m/s]	min. A_d [kN]
	Roof width B [m]	Span L [m]												
1	7.66	5.71	Light	0.172	0.154	2	6.71	1.74	26.6	-3.17	-0.82	0.91	38.20	-12.8
			Standard	0.203	0.175		6.67	1.73	26.6	-6.44	-1.67	1.85	54.46	-26.6
			Heavy	0.227	0.196		6.64	1.72	26.6	-6.46	-1.67	1.86	54.54	-26.6
2	8.61	6.66	Light	0.172	0.154	2	5.94	1.54	26.6	-2.36	-0.61	0.68	33.0	-10.6
			Standard	0.203	0.175		5.90	1.53	26.6	-5.74	-1.49	1.65	51.45	-26.6
			Heavy	0.227	0.196		5.87	1.52	26.6	-5.75	-1.49	1.66	51.53	-26.6
3	9.57	7.61	Light	0.172	0.154	2	5.33	1.38	26.6	-1.84	-0.48	0.53	29.14	-9.0
			Standard	0.203	0.175		5.29	1.37	26.6	-5.19	-1.34	1.49	48.90	-26.6
			Heavy	0.227	0.196		5.26	1.36	26.6	-5.21	-1.35	1.50	48.99	-26.6
4	10.52	8.56	Light	0.172	0.154	2	4.51	1.17	24.9	-1.49	-0.38	0.43	26.16	-7.8
			Standard	0.203	0.175		4.46	1.16	24.9	-4.73	-1.23	1.36	46.71	-26.6
			Heavy	0.227	0.196		4.75	1.23	26.6	-4.75	-1.23	1.37	46.80	-26.6
5	11.47	9.51	Light	0.172	0.154	2	3.61	0.93	22.0	-1.23	-0.32	0.35	23.80	-6.9
			Standard	0.203	0.175		3.56	0.92	22.0	-4.06	-1.05	1.17	43.23	-24.7
			Heavy	0.227	0.196		4.33	1.12	26.6	-4.07	-1.06	1.17	43.33	-24.7
6	12.42	10.46	Light	0.172	0.154	2	2.94	0.76	19.7	-1.04	-0.27	0.30	21.89	-6.2
			Standard	0.203	0.175		2.90	0.75	19.7	-3.38	-0.88	0.97	39.46	-22.1
			Heavy	0.227	0.196		3.98	1.03	26.6	-3.40	-0.88	0.98	39.57	-22.1
7	13.37	11.41	Light	0.172	0.154	2	2.43	0.63	17.8	-0.90	-0.23	0.26	20.32	-5.6
			Standard	0.203	0.175		2.39	0.62	17.8	-2.86	-0.74	0.83	36.33	-20.0
			Heavy	0.227	0.196		3.67	0.95	26.6	-2.88	-0.75	0.83	36.45	-20.0
8	14.32	12.36	Light	0.172	0.154	2	2.04	0.53	16.3	-0.78	-0.20²	0.23	19.01	-5.1
			Standard	0.203	0.175		2.00	0.52	16.3	-2.46	-0.64	0.71	33.70	-18.3
			Heavy	0.227	0.196		3.19	0.83	25.1	-2.48	-0.64	0.72	33.82	-18.3
9	15.27	13.31	Light	0.172	0.154	2	1.73	0.45	15.0	-0.70	-0.18²	0.20	17.90	-4.7
			Standard	0.203	0.175		1.68	0.44	15.0	-2.15	-0.56	0.62	31.45	-16.8
			Heavy	0.227	0.196		2.71	0.70	23.1	-2.17	-0.56	0.62	31.59	-16.8
10	16.22	14.27	Light	0.172	0.154	2	1.47	0.38	13.8	-0.62	-0.16²	0.18	16.95	-4.3
			Standard	0.203	0.175		1.43	0.37	13.8	-1.89	-0.49	0.54	29.51	-15.5
			Heavy	0.227	0.196		2.32	0.60	21.3	-1.91	-0.49	0.55	29.66	-15.5
11	17.17	15.22	Light	0.172	0.154	2	1.27	0.33	12.9	-0.57	-0.15²	0.16	16.14	-4.0
			Standard	0.203	0.175		1.23	0.32	12.9	-1.68	-0.44	0.48	27.83	-14.5
			Heavy	0.227	0.196		2.00	0.52	19.8	-1.70	-0.44	0.49	27.98	-14.4

Table 4-1

Keder Roof XL – load-bearing capacities of mono-pitch roof with 18° roof angle (structurally determined mounting)							Maximum snow load			Maximum wind suction				
							max. \bar{s}_d [kN/m]	max. s_c [kN/m ²]	max. A_d [kN]	max. \bar{w}_d [kN/m]	max. w_e [kN/m ²]	max q_{eff} ($c_p = -0.9$) [kN/m ²]	max. v_{eff} [m/s]	min. A_d [kN]
12	18.13	16.17	Light	0.172	0.154	2	1.10	0.28	12.0	-0.52	-0.13²	0.15	15.43	-3.8
			Standard	0.203	0.175		1.05	0.27	12.0	-1.51	-0.39	0.43	26.35	-13.5
			Heavy	0.227	0.196		1.75	0.45	18.6	-1.53	-0.40	0.44	26.51	-13.5
13	19.08	17.12	Light	0.172	0.154	2	0.95	0.25	11.3	-0.48	-0.12²	0.14	14.81	-3.5
			Standard	0.203	0.175		0.91	0.24	11.3	-1.36	-0.35	0.39	25.04	-12.7
			Heavy	0.227	0.196		1.52	0.39	17.4	-1.38	-0.36	0.40	25.22	-12.7
14	20.03	18.07	Light	0.172	0.154	2	0.83	0.22	10.6	-0.44	-0.11²	0.13	14.26	-3.3
			Standard	0.203	0.175		0.79	0.20	10.6	-1.24	-0.32	0.36	23.88	-12.0
			Heavy	0.227	0.196		1.33	0.35	16.4	-1.26	-0.33	0.36	24.06	-11.9
15	20.98	19.02	Light	0.172	0.154	2	0.73	0.19	10.1	-0.41	-0.11²	0.12	13.78	-3.2
			Standard	0.203	0.175		0.69	0.18	10.1	-1.13	-0.29	0.33	22.85	-11.3
			Heavy	0.227	0.196		1.17	0.30	15.5	-1.15	-0.30	0.33	23.03	-11.3
16	21.93	19.97	Light	0.172	0.154	2	0.64	0.17	9.5	-0.39	-0.10²	0.11	13.35	-3.0
			Standard	0.203	0.175		0.60	0.15	9.5	-1.04	-0.27	0.30	21.91	-10.7
			Heavy	0.227	0.196		1.04	0.27	14.7	-1.06	-0.27	0.31	22.11	-10.7

Table 4-2

- 1) The recommended minimum load of 0.10 kN/m² is below the target. The usability of the roof structure must be inspected in this case.
- 2) The usability of the roof structure must be inspected in this case. If necessary additional structural measures against wind suction must be taken.

9. INDIVIDUAL VERIFICATION

For individual verification of the structural strength of a roof structure, the lattice-like roof trusses can be modelled in simplified form as bending beams (see Fig. 34). The effective cross-sectional values A_{eff} and I_{eff} as per Fig. 35 can be assumed here for the beam elements. Deformation components as a result of the shear stiffness are not covered by this.

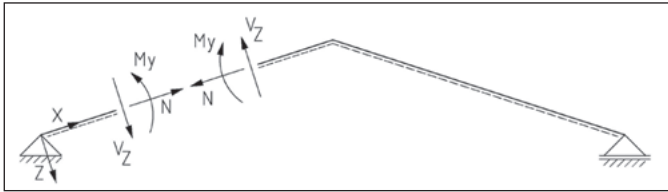

Fig. 34

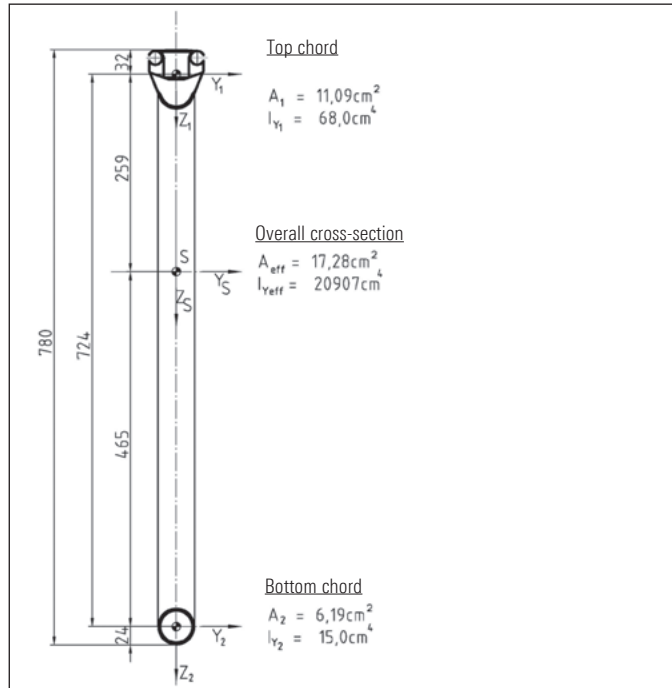

Fig. 35

The stress capabilities $V_{z,R,d}$ and $M_{y,R,d}$ of the replacement bending beam are listed in Table 5. The stress capability of the belt forces (see Table 5) is verified with the simultaneous effect of normal force and bending moment. For this verification, the normal force stresses in the top and bottom chords are determined from the beam section sizes N and M_y according to Fig. 36 and compared with the stress capability values of the top and bottom chords.

	Com- pression force	Tension force	Replacement beam			
			Bending moments ($z_s = 0.724$ m)		Shear force	
	max. $N^-_{R,d}$ [kN]	max. $N^+_{R,d}$ [kN]	max. $M^+_{y,R,d}$ [kNm]	max. $M^-_{y,R,d}$ [kNm]	$V_{z,R,d}$ [kN]	
Diagonal strut	-29.1	29.1	-	-	25.0	
Heavy	Top chord with $s_K = 1.0$ m	-113.4	113.4	66.9	-48.8	-
	Bottom chord with $s_K = 1.0$ m	-67.4	92.4			
Standard	Top chord with $s_K = 2.0$ m	-60.0	113.4	43.4	-48.8	-
	Bottom chord with $s_K = 1.0$ m	-67.4	92.4			
Light	Top chord with $s_K = 2.0$ m	-60.0	113.4	43.4	-13.7	-
	Bottom chord with $s_K = 2.0$ m	-18.9	92.4			

Table 5

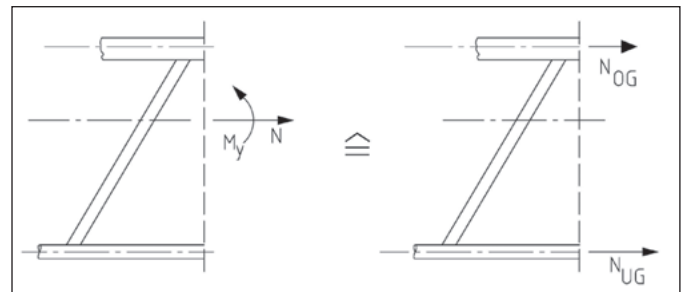

Fig. 36

$$N_{OG} = 0.64 * N - M_y / 72.4$$

$$N_{UG} = 0.36 * N + M_y / 72.4 \quad M_y \text{ [kNm]}$$

Support scaffolding

Calculate the support scaffolding separately for every specific case. The loads resulting from the roof and the scaffolding must be traced all the way to the ground for assembly.

The support forces of the roof structure as a result of dead weight and wind suction can be found in Tables 2 and 3. Dead weights and cross-sections of individual components for the SpeedyScaf or Allround support scaffolding can be found in the respective approvals.

For verification of the stability of the support scaffolding, DIN EN 12811 applies.

Tip: It is recommended in any event that the standards of the support scaffolding be secured with locking pins.

Wind suction: hall closed on all sides: $C_p = -0.60$

10. COMPONENTS

Keder Roof XL Lattice Beam

L = 2.0 m, Art. No. 5975.200, weight 17.3 kg

L = 3.0 m, Art. No. 5975.300, weight 24.4 kg

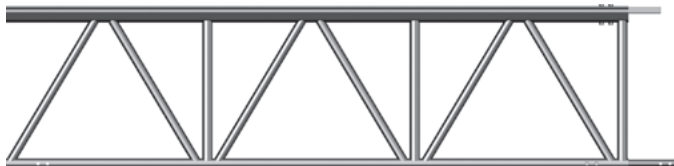

Keder Roof XL Ridge Section 18°

L = 2.1 m, Art. No. 5975.110, weight 24.5 kg

Keder Roof XL Ridge Section 20°

L = 2.1 m, Art. No. 5975.120, weight 24.5 kg

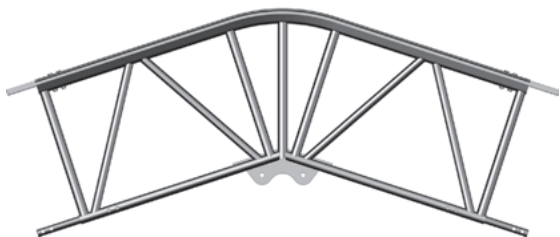

Keder Roof XL Eaves Section

L = 2.0 m, Art. No. 5975.100, weight 14.3 kg



Brace

L = 2.57 m, Art. No. 5940.257, weight 10.0 kg

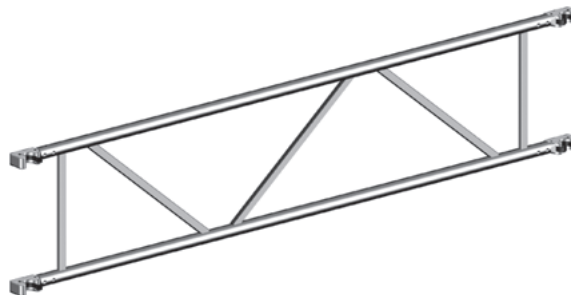

Mono-pitch roof lattice beam

L = 1.06 m, Art. No. 5975.106, weight 14.5 kg

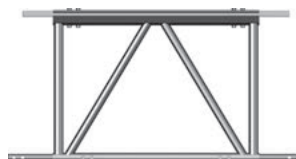

Horizontal diagonal brace

L = 2.87 m (1 m post spacing), Art. No. 5939.100, weight 4.2 kg

L = 3.37 m (2 m post spacing), Art. No. 5939.200, weight 5.0 kg



Keder roof ledger

L = 2.57 m, Art. No. 5972.257, weight 4.2 kg



Keder Roof XL Support

L = 0.73 m, Art. No. 5975.073, weight 19.1 kg

L = 1.09 m, Art. No. 5975.109, weight 22.4 kg



Keder rail seal

Art. No. 5971.001, weight 0.1 kg



Tie fastening

Art. No. 5975.000, weight 6.1 kg

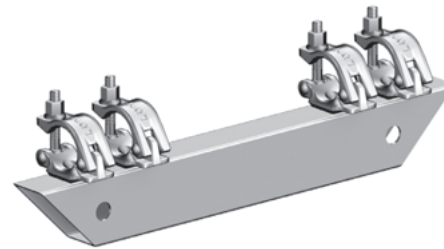

Special bolt M12 x 60 mm, with nut

Art. No. 4905.060, 50 pcs., 0.1 kg

Special bolt M12 x 90 mm, with nut

Art. No. 5975.090, 25 pcs., 0.1 kg

Lattice beam tube securing pin, dia. 12 mm, with flat head

Art. No. 4905.666, weight 0.1 kg

Pin, dia. 12 x 95 mm, alternative to special bolt

Art. No. 5976.090, 25 pcs., weight 0.1 kg

Pin, dia. 12 x 65 mm, alternative to special bolt

Art. No. 4905.065, 50 pcs., weight 0.1 kg

with locking pin, dia. 2.8 mm

Art. No. 4905.000, 50 pcs., weight 0.1 kg



Tie connection, tension strap

Art. No. 5975.010, weight 2.0 kg



Tie connection for threaded rod

Art. No. 5975.020, weight 2.2 kg

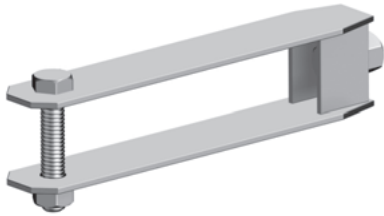

Tie connection piece

Art. No. 5975.030, weight 0.8 kg



Tie rod connector, WAF 30 x 90

Art. No. 5976.000, weight 0.4 kg



Tie threaded rod

L = 2.0 m, Art. No. 5976.200, weight 2.9 kg

L = 3.0 m, Art. No. 5976.300, weight 4.4 kg

L = 4.0 m, Art. No. 5976.400, weight 5.8 kg

L = 5.0 m, Art. No. 5976.500, weight 7.3 kg

Lashing strap 5 t, 5 m with ratchet

L = 5.0 m, Art. No. 5976.600, weight 2.8 kg



Polyester lashing strap, 6 m with wedge lock

L = 6.0 m, Art. No. 5976.610, weight 0.2 kg



Tarpaulin insertion set

L = 3.0 m, Art. No. 5971.400, weight 5.8 kg



Roller for tarpaulin insertion, for 48.3 mm tube

Art. No. 5971.401, weight 0.4 kg



Keder roof tarpaulin

B1 = 2.57 m, Art. No. 5972.xxx

B2 = 2.07 m, Art. No. 5972.xxx

For tarpaulins see price list for protective systems



Keder roof gable tarpaulin

B1 = 2.57 m, Art. No. 5972.xxx

B2 = 2.07 m, Art. No. 5972.xxx

For tarpaulins see price list for protective systems



Trolley T12

Art. No. 5938.026, weight 16.3 kg

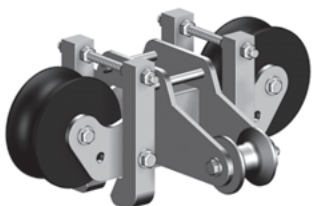

Tarpaulin clip

Art. No. 5971.140, 50 pcs., weight 0.1 kg



Rail, 3.0 m

Art. No. 5941.300, weight 53.4 kg



Adapter for rail T12

L = 0.80 m, Art. No. 5938.027, weight 5.5 kg



Connector for trolley

Art. No. 5938.019, weight 11.1 kg



Roof support for Keder Roof XL

18° rigid, 0.73 m with Allround rosettes
Art. No. 5938.030, weight 11.0 kg



Lattice girder spigot T4, dia. 38 mm

L = 0.44 m, Art. No. 4922.000, weight 1.9 kg



Locking pin, red, dia. 11 mm

Art. No. 4000.001, weight 0.2 kg



Double coupler

WAF 19, Art. No. 4700.019, weight 1.3 kg
WAF 22, Art. No. 4700.022, weight 1.3 kg



PSA safety harness AX 60 C with extension 0.5 m

Art. No. 5969.160, weight 1.8 kg



PSA connector BFD Y-version

Art. No. 5969.600



PSA backpack, without contents

Art. No. 5969.800, weight 0.6 kg



SYSTEMS – EXAMPLES FOR ASSEMBLY

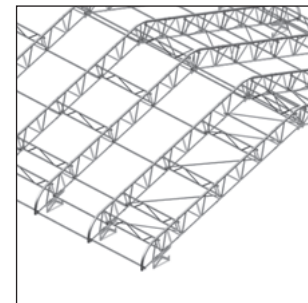
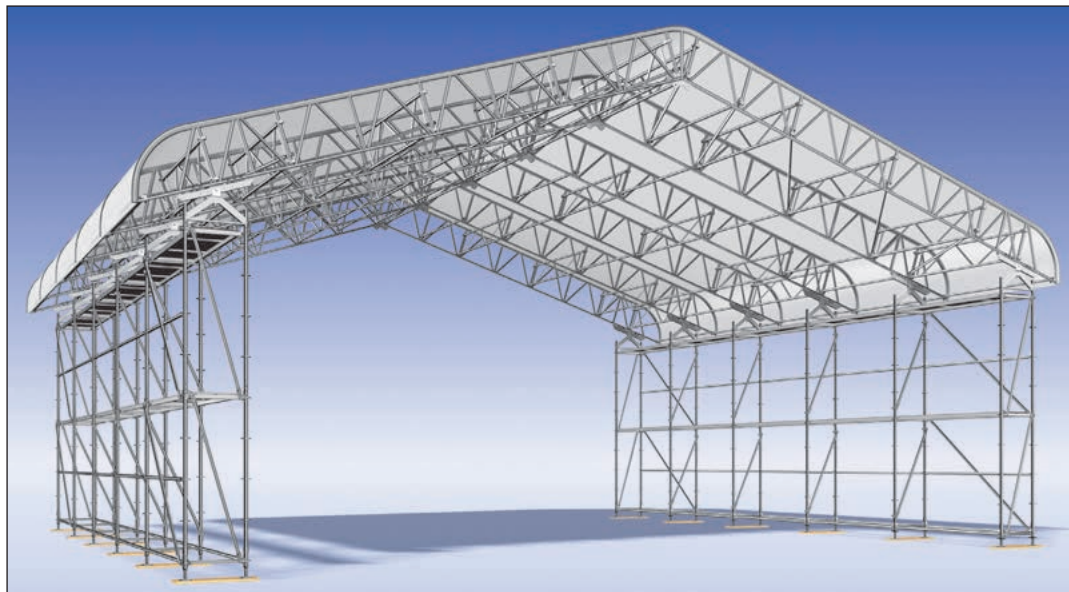

Double-pitch roof
("Light" variant)
Truss outer dimension 17.30 m

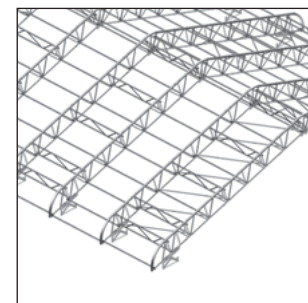
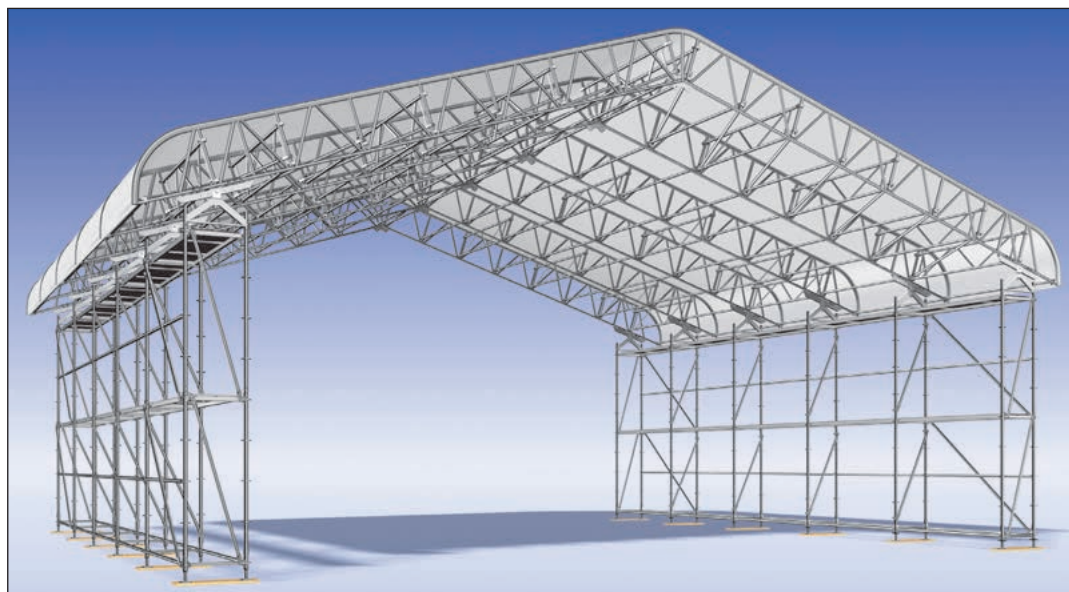

Double-pitch roof
("Standard" variant)
Truss outer dimension 17.30 m

SYSTEMS – EXAMPLES FOR ASSEMBLY

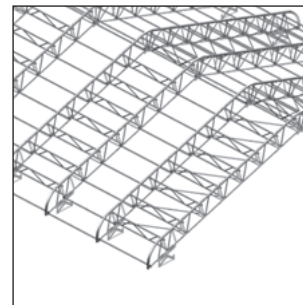
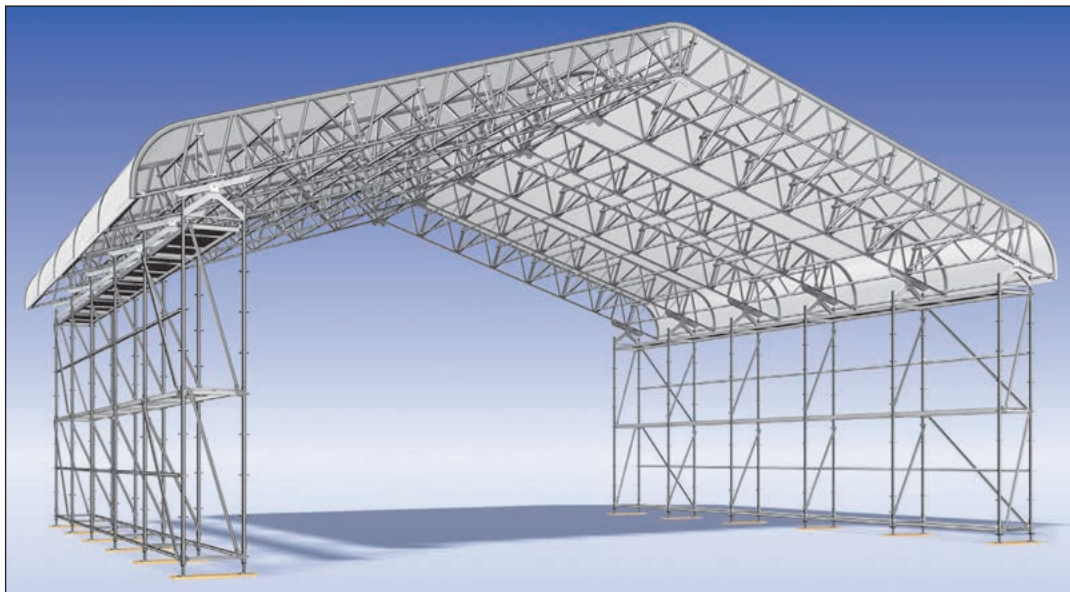

Double-pitch roof
("Heavy" variant)
Truss outer dimension 17.30 m

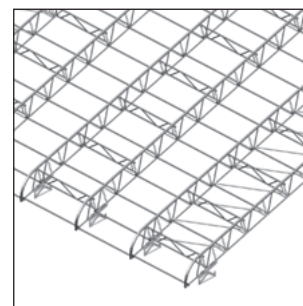
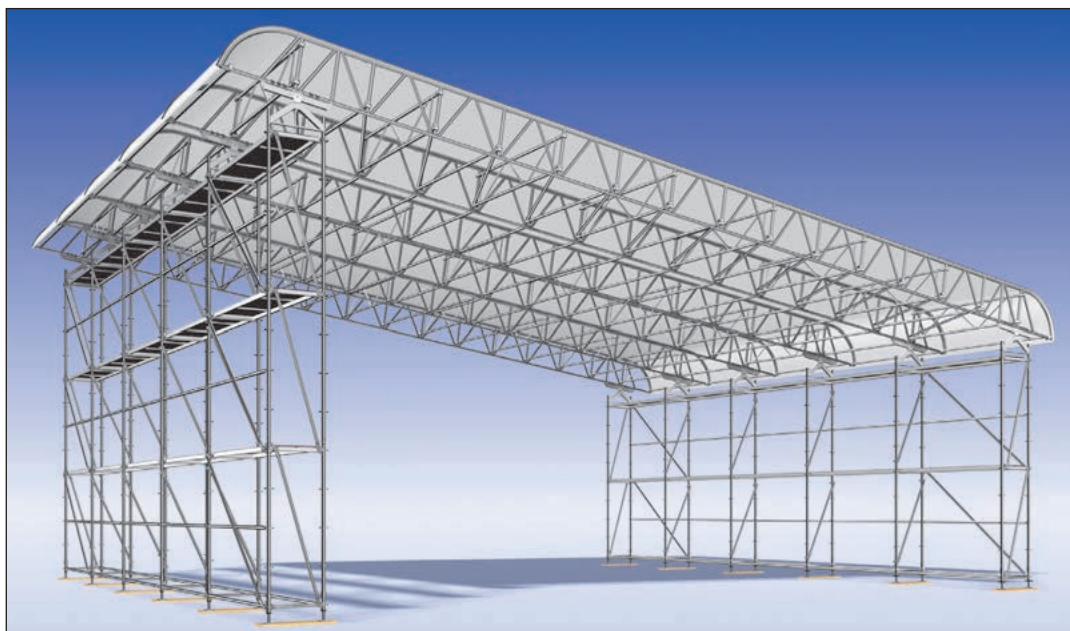

Mono-pitch roof
("Standard" variant)
Truss outer dimension 15.30 m



Layher® 

More Possibilities. The Scaffolding System.

Wilhelm Layher GmbH & Co. KG
Scaffolding Grandstands Ladders

Ochsenbacher Strasse 56
74363 Gueglingen-Eibensbach
Germany

P.O. Box 40
74361 Gueglingen-Eibensbach
Germany
Telephone +49 (0) 71 35 70-0
Telefax +49 (0) 71 35 70-265
E-mail info@layher.com
www.layher.com

