



MULTISTRIPPER / MULTISTRIPPER VARIO

MANUAL



SCANMASKIN
MACHINES—MINERALS—KNOW-HOW

Kära kund!

Tack för att du har valt Scanmaskin

Vi önskar dig lycka till med din nya Multistripper och hoppas att den lever upp till dina förväntningar.

Scanmaskin Sweden AB



Per-Anders Bardh
CEO

Address:

Scanmaskin Sweden AB

Box 187

SE-437 22 Lindome / Gothenburg

Sweden

Telephone: +46 (0) 31 99 49 70

Fax: +46 (0) 31 99 48 70

www.scanmaskin.com

Viktig information!

Denna bruksanvisning behandlar endast strippe **Multistripper** godkänd av Scanmaskin Sweden AB.

Om Multistripper används för andra ändamål eller hanteras på annat sätt än som anges i denna bruksanvisning, fransäger sig Scanmaskin Sweden AB allt ansvar.

Läs bruksanvisningen innan användning av strippe Multistripper. Reservdelar och blad som används med Multistripper måste vara godkända av Scanmaskin Sweden AB.

Innehåll

<u>1</u>	<u>Användning</u>	5
1.1	<u>Generell information</u>	5
1.2	<u>Ljudnivå</u>	5
1.3	<u>Vibrationer</u>	5
<u>2</u>	<u>Underhållning</u>	5
2.1	<u>Smörjning</u>	5
2.1.1	<u>Smörjanvisning</u>	6
2.2	<u>Byte av kniv</u>	7
2.2.1	<u>Vägledning för montering och användning av Multistrippers knivar</u>	7
<u>3</u>	<u>Reservdelsritning</u>	8
<u>4</u>	<u>Garanti</u>	10
<u>5</u>	<u>EG-deklaration</u>	11
<u>6</u>	<u>KONTAKT</u>	12

1. Användning

Maskinen används till all skära bort pålimmade golvmaterial (linoleum, mattor etc.). Den arbetar med den kniv som är motordriven och på så vis vibrerar in emellan limfogen. Mattstrippern är självgående så det är därför inte nödvändigt att trycka kniven mot limfogen. Maskinen är även utrustad med "friläge" så att man kan använda den manuellt för efterputsning av beläggningsrester.

1.1 Generell information

Arbetet utförs bäst och mest rationellt av 2 man, den ena handhar maskinen medans den andre tar bort den lösa beläggningen.

Vid borttagning av beläggningar som sitter fast hårt eller som är klibbiga med otorkat lim kan det vara nödvändigt att man drar lätt i beläggningen för att man lättare skall kunna skära av med strippern.



OBS! Håll knivarna vassa och byt ut defekta knivar.

1.2 Ljudnivå

Maskinens ljudnivå är i enlighet med EN 25349 på 91 dB (A), så hörselskydd måste användas. Vid efterarbete är dock ljudnivån bara 83 dB (A) hörselskydd är då ej nödvändigt.

1.3 Vibrationer

Vibrationsnivån är i enlighet med EN 25349 på 2,75 3,75 3,23 i X Y och Z, och därför bör man inte använda maskinen mer än 3 timmar dagligen.



OBS: Om maskinen inte vill fungera vid korrekt inkoppling så är det dags att smörja. Kom ihåg alla smörjställen.

2. Underhållning

2.1 Smörjning

Maskinen skall smörjas var 4:e drift timma (2 ggr dagligen) på de ställen som är markerade med pilar (se smörjnings schema). Använd en tunn maskinolja eller en året runt motorolja, API SF / CC 15W-40.



Viktigt: Vid smörjning, sätt maskinen i "friläge". Detta är viktigt för att uppnå en korrekt smörjning.

2.1.1 Smörjanvisning

För en problemfri drift är det nödvändigt att smörja på de ställen som pilarna visar 1-2 gånger dagligen.



Viktigt! Vid smörjning av de ställen som är angivna i cirkeln måste maskinen först ställas i "friläge".

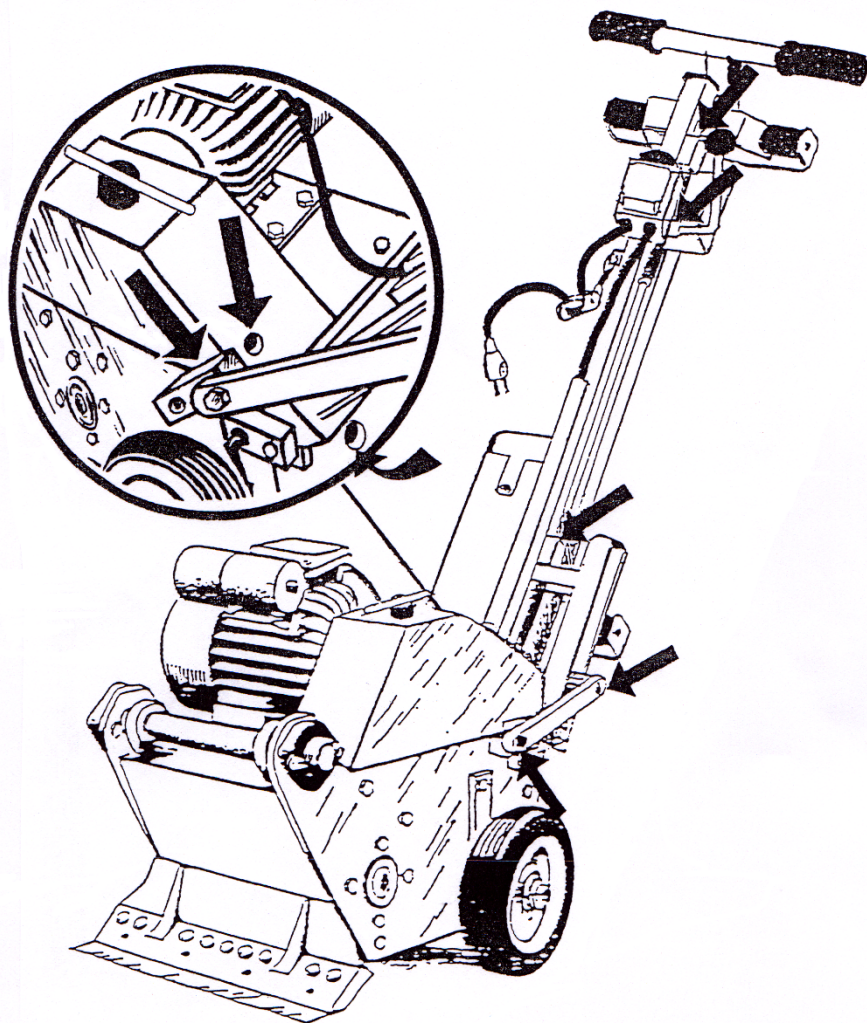

2.2 Byte av kniv

Kniven sitter fast med 4 stycken skruvar med invändig sexkant. Skruvarna lossas med nyckeln som sitter i hållaren ovanpå maskinen.



OBS! Innan du byter kniven så skall sladden till maskinen vara utdragen!

2.2.1 Vägledning för montering och användning av Multistrippers knivar

Kniv typ 1: RAKT BLAD

Det mest användbara bladet.

Användningsområde:

- Används på alla typer av golvmaterial.
- Det raka bladet förutsätter att golvmaterialet förskärs i strimlor med handkniv.

Montering: Monteras alltid med den fasade sidan upp.

Kniv typ 2: SIDOKNIV HÖGER & VÄNSTER

Lösa sidoskär som används tillsammans med det raka bladet.

Användningsområde:

- Nålfilt, vinyl, PVC och linoleum.
- Vid användning av sidobladen behöver inte golvmaterialet förskäras med handkniv

Montering: Från sidan under kniv typ 1

Kniv typ 3: UPPVIKT BLAD

Universal kniv med fasta sidoknivar

Användningsområde:

- Används på alla golvbeläggningar.
- Mindre lämplig på textil.
- Golvbeläggningen behöver inte förskäras med handkniv.
- Ingen smuts kilar fast.

Montering: Som typ 1

3. Reservdelsritning

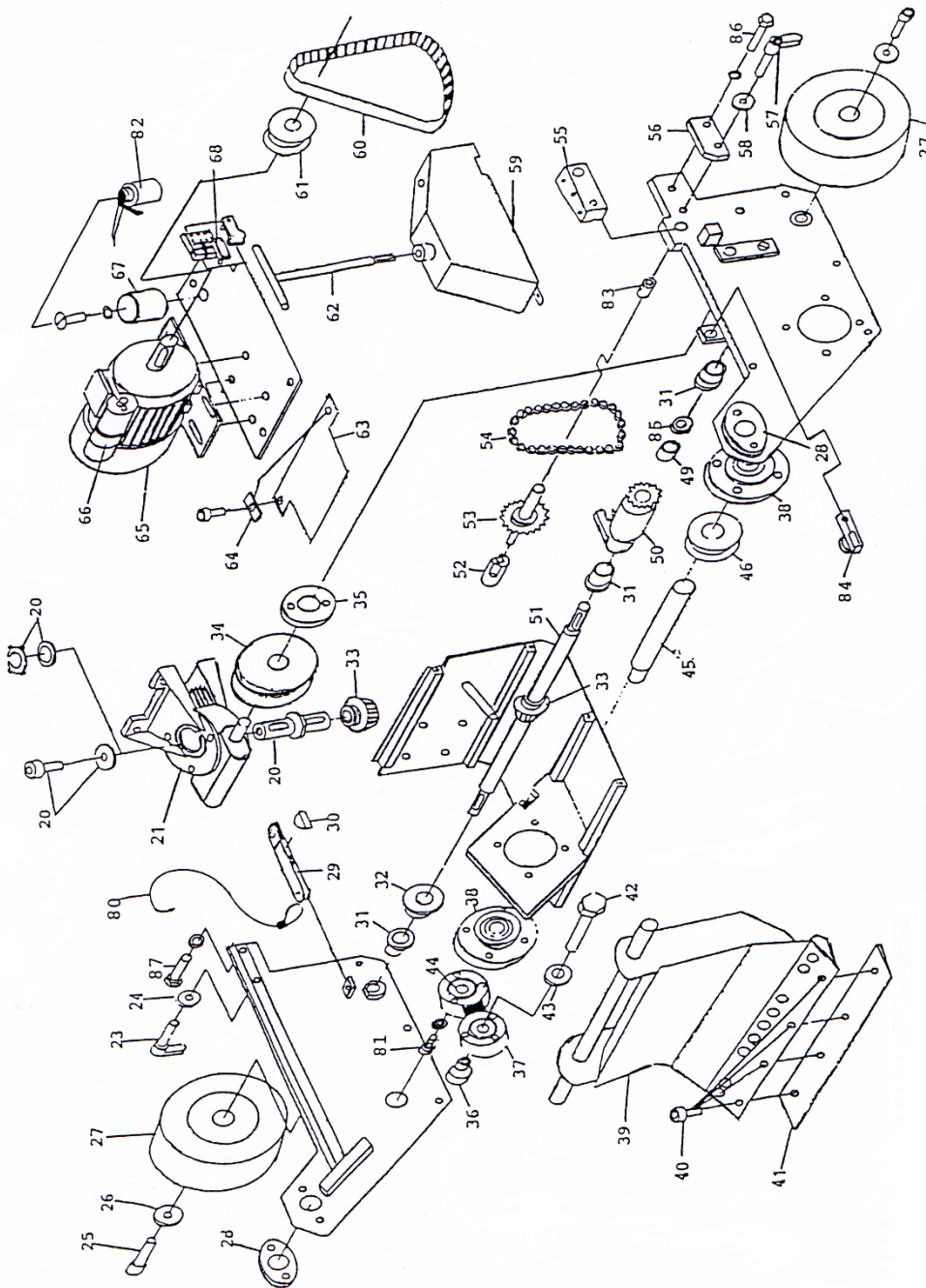

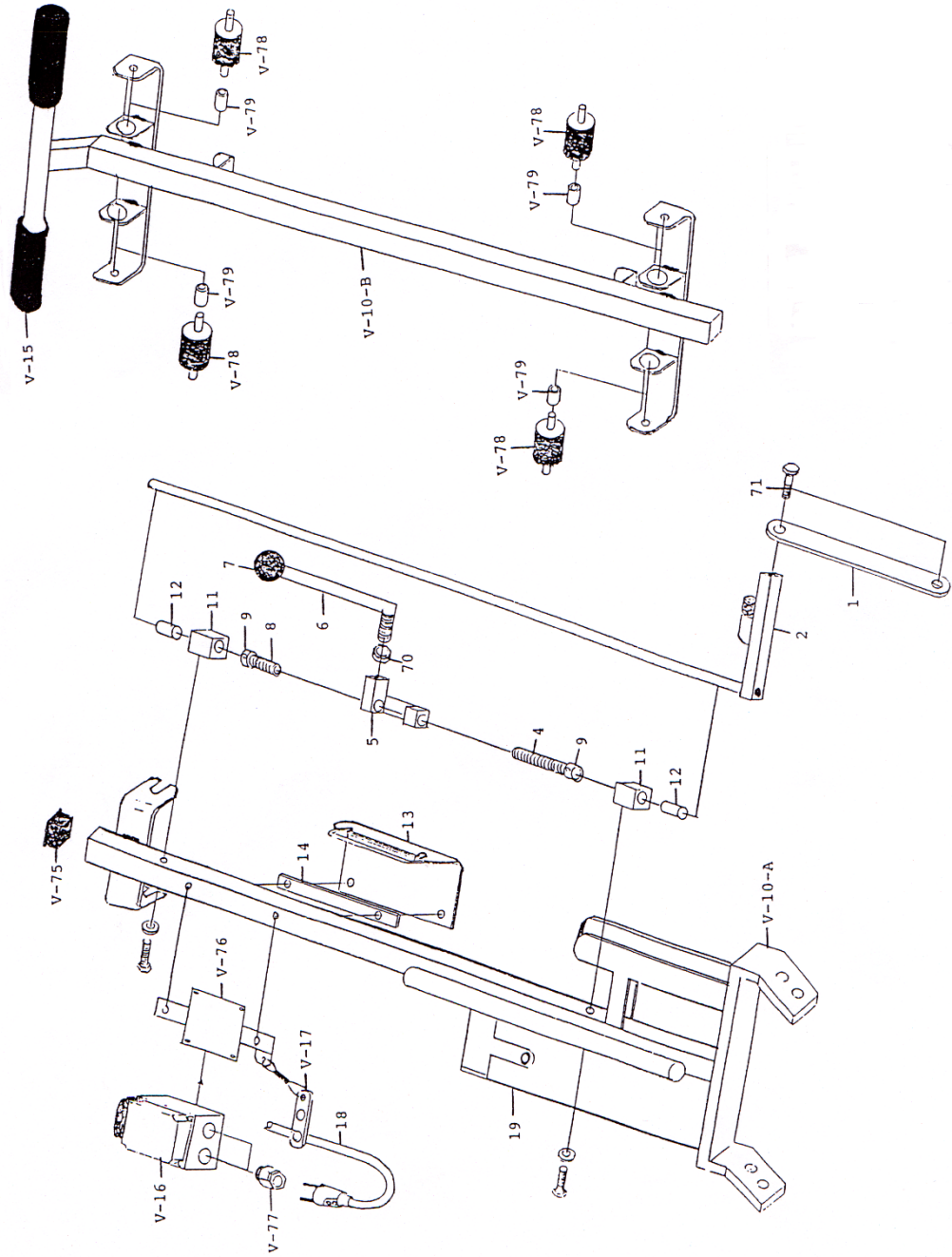

4. Garanti

Denna produkt från Scanmaskin Sweden AB levereras med tolv månaders garanti. Om produkten inte fungerar tillfredsställande under denna period, kommer Scanmaskin att återställa produkten till fullt fungerande skick för den användning produkten är avsedd för, utan kostnad för arbete eller reservdelar, enligt följande villkor:

1. Garantin gäller endast för personer som har lagstadgad rätt till utrustningen under garantiperioden.
2. Tillverkarens ansvar är begränsat till reparation av defekta delar eller byte av dessa delar enligt tillverkarens bedömning. Kostnader och risker för transporter samt demontering och ominstallation av produkten/produkterna och andra direkta eller indirekta kostnader relaterade till reparationen i fråga, täcks inte av denna garanti.
3. Regelbundna kontroller, justeringar, underhållsarbete och förändringar ingår inte i garantin.
4. Scanmaskin ansvarar inte för skador på slipskivor eller annan liknande utrustning.
5. Garantin gäller endast för fel på material och konstruktion och gäller inte i följande fall:
 - a. Skada orsakad av olyckor, vårdslöshet, förändringar, användning av icke-original reservdelar eller slipverktyg, samt felaktig användning eller installation.
 - b. Skada orsakad av blixtnedslag, vatten, eld, skadegörelse, felaktig nätspänning, felaktig ventilation eller andra orsaker som ligger utanför tillverkarens kontroll.
6. Scanmaskin förbehåller sig rättigheten att ändra konstruktionen eller att genomföra förbättringar utan skyldighet att uppdatera tidigare tillverkade produkter.
7. Alla garantireparationer ska utföras av Scanmaskin eller av en verkstad som är auktoriserad av Scanmaskin. Kostnader för reparationer som har utförts av en oauktorerad verkstad kommer inte att ersättas av Scanmaskin. Om sådana reparationer skadar produkten täcks dessa skador inte av garantin.

5. EG-deklaration

Försäkran om CE-överensstämmelse

Tillverkare

Adress

Scanmaskin Sweden AB

Heljesvägen 10

427 36 Lindome/Göteborg

Sverige

Produkt

Produktnamn

Serienummer

Stripper

Multistripper

Produkten uppfyller följande EU-riktlinjer

Maskindirektiv

EMC

LVD

Harmoniserade standarder

2006/42/EG

2004/108/EG

2006/95/EG

EN ISO 13850

EN ISO 12100-1/-2

EN ISO 60204-1

Utfärdandeplats

Lindome/Göteborg/Sverige

Auktoriserad representant

Per-Anders Bardh

CEO

Scanmaskin Sweden AB



Per-Anders Bardh

CEO

6. KONTAKT

Sverige Huvudkontor
Heljesvägen 10
Box 187
SE-437 22 Lindome

Telefon: +46 (0) 31 99 49 70
Fax: +46 (0) 31 99 48 70
E-post: info@scanmaskin.se
Hemsida: www.scanmaskin.se

Danmark
Torvegade 22
DK-7330 Brande

Telefon: +45 97 18 00 58
Fax: +45 97 18 45 58
E-post: info@scanmineral.dk
Hemsida: www.scanmaskin.se

Norge

Maridalsveien 91
NO-0461 Oslo

Telefon: +47 -63 87 60 00
Fax: +47 -63 87 60 01
E-post: info@scanmaskin.no
Hemsida: www.scanmaskin.no

Finland

Raudoittajantie 3A
FIN-06450 Porvoo / Borgå

Telefon: +358 10 292 4700
E-post: info@scanmaskin.fi
Hemsida: www.scanmaskin.fi

USA

18868 72nd AVE S
WA-98032 KENT

Phone: +1 425 209 0147
E-mail: info@scanmaskin.com
Hemsida: www.scanmaskin.com

Dear Customer!

Thank you for choosing Scanmaskin as your supplier.

We wish you all the best with your new Multistripper and hope that it meets your expectations.

Scanmaskin Sverige AB



Per-Anders Bardh
Managing Director

Address:

Scanmaskin Sweden AB

Box 187

SE-437 22 Lindome / Gothenburg

Sweden

Telephone: +46 (0) 31 99 49 70

Fax: +46 (0) 31 99 48 70

www.scanmaskin.com

Important Information!

This Manual only concerns the stripper "**Multistripper**" approved by Scanmaskin Sweden AB.

If **Multistripper** is used for other purposes or handled in ways other than that described in this Manual, Scanmaskin Sweden AB disclaims all responsibility.

Especially note the section "3. Safety instructions". Read the Manual before using the stripper Multistripper. The spare parts and blades used on Multistripper must be approved by Scanmaskin Sweden AB.

1. Table of content

1	User guide for operator.....	17
1.1	Choice of blade	17
2	Technical specification.....	17
3	Safety instructions	18
3.1	Safety precautions.....	18
3.2	Organizational measures.....	18
3.3	Personnel selection and qualification.....	19
3.4	Safety regarding operation of machine.....	20
3.5	Electical safety.....	20
3.6	Noice level.....	21
3.7	Vibrations.....	21
3.8	Transportation.....	21
4	Repair and maintenance	21
5	Spare parts	22
6	Warranty	24
7	EC-declaration	25
8	Contact information	26

1. User guide for operator

The Multistripper is used to cut loose glued down flooring materials (Lino, Vinyl, carpet etc.) from the underlay. It works by means of a blade that by eccentric drive vibrates into the glue joint. The Multistripper is self-propelled and it is not necessary to force it into the glue joint. The machine is equipped with neutral gear allowing it to be used manually for removal of left-over flooring material etc. The Multistripper is for indoor use only and must not be cleaned by use of a high-pressure cleaner (water). This will lead to corrosion of the ball bearings and the transmission. When starting up always check that the blade is sharp, if not, the power supply for the machine must be switched off before changing the blade. The blade is mounted by use of 4 Unbrako socket screws. The screws are loosened with the Allen key. Switch on the power supply and the vibration will start. Take the gear handle down and the machine will move forward.

1.1 Choice of blade

The most common blade is the Normal blade used on all types of flooring material. It is necessary to cut the carpet into long pieces before use. Mounted with bevel facing upwards.

Normal blade 320 mm.

If the flooring material is difficult to remove and the blade has a tendency to slip, the Aggressive blade with a 15 degree bend may be the solution.

Aggressive blade 320 mm.

The three- edged blade with self -scoring corners. No need to pre-cut carpet into long pieces. It can be used on all flooring materials, however, not suitable for use on loop carpets. When removing flooring materials that are particularly difficult to remove, the width of the cut can be adjusted without stopping to 2/3 or 1/2. This is very useful.

Three- edged blade

2. Technical specification

Motor: AC standard motor, surface cooled, 230 volts, 11.5 Amp. 750 watt, 2800 rpm

Blade: Rocker-mounted, blade width 32 cm

Clutch: Mechanical

Measurements:

Height: 90 cm

Width: 34 cm

Length: 100 cm

Weight: 70 kg

CE sign

3. Safety instructions

The Multistripper is only for indoor use on glued down flooring materials, not for use on outdoor roofing felt or the like, the Warranty will cease to apply in this case.

Always unplug from the main power supply when changing the blade or when not in use. The machine is equipped with a no voltage release switch. In case of loss of mains voltage, it ensures that the power is cut off and that the machine does not start once mains voltage is back on.

3.1 Safety precautions



Any machine, if it is not used according the regulations, may be hazardous for operating, setting-up and service personnel. The operating authority is responsible for compliance with the safety regulations during operation and maintenance, and for the use of safety devices supplied with the machine, as well as the provision of appropriate additional safety devices!

Eye and ear protection must be worn at all times.

Never operate the machine when it's not in its upright position.

Make sure there is no debris in the work area.

Check the work area for screws or other hard objects in the concrete. Don't use the machine if there are any foreign objects stuck into the surface. Such objects must be removed prior to operation of machine.

3.2 Organizational measures

The user guide is to be kept near the location where the machine is being operated and must be within reach at all times.

In addition to this user guide general and legal regulations regarding accident prevention and environmental protection must be complied with as per local regulations.

Such duties may, for example, relate to the handling of hazardous substances, or to the provision and wearing of personal protection equipment, as well as compliance with traffic regulations.

The user guide must be supplemented by other instructions, including the duty to supervise and report incidents relating to particular working practices, for example work organization, work procedures and personnel safety.

Personnel entrusted with working with the machine must read the User Guide before starting work, in particular the "3 Safety Regulations" chapter. To read these instructions after work is commenced is too late. This particularly applies to incidental activities such as setting up the equipment, carrying out maintenance work or training staff to work with the machine.

From time to time the working practices of the operators are to be checked by a supervisor especially to the items regarding awareness of safety and hazards.

Operators must tie back long hair, and not wear loose clothing or jewelry including rings. There is a risk of injury through items getting caught, or being drawn into moving machinery.

Eye and ear protection must be worn at all times!

Use personnel protection equipment if necessary or required by local regulations! Take notice of all safety and hazard notices on the machine!

All safety and hazard notices at or on the machine must be kept complete and legible!

If safety-critical changes occur to the machine or its working method, the machine must be shut down immediately! The cause of the fault must be established, and rectified.

Changes, add-ons or conversion to the machine, which might impair safety, must not be made, without the manufacturer's permission!

This applies in particular to the fitting and adjustment of safety devices.

Spare parts must comply with the technical requirements specified by the manufacturer. This is always guaranteed if original spare parts are used.

Intervals for recurring checks and inspections specified in this User Guide must be complied with!

To perform maintenance work correctly it is imperative to be equipped with the proper tools for the task in question.

Repairs may only be made by Scanmaskin Sweden AB certified service technicians.

Some work may generate sparks under certain circumstances. Personnel working with the machine must therefore be aware of the risk of fire and how to handle a fire situation properly.

Do not use the machine in areas with highly flammable and/or explosive materials.

3.3 Personnel selection and qualification

Fundamental duties:

- Work with the machine may only be undertaken by trained personnel.
- Specify clearly the responsibilities of personnel for operation, setting up, servicing and maintenance work!
- Make sure that only authorized personnel operate or work with the machine!
- Define responsibilities of the machine operator, with regard to traffic safety regulations, and inform him not to take instructions from third parties who may not be complying with the local safety requirements.
- Personnel, who are being trained to operate equipment, may only use the machine under constant supervision of an experienced person!

- Work on electrical equipment may only be undertaken by a skilled electrician or by trained persons under the supervision of a skilled electrician, as well as in accordance with the local electrical engineering regulations.

3.4 Safety regarding operation of machine



Do not allow any method of working that impairs safety!

Recognized official procedures have to be used to ensure the machine is operated in safe and best conditions.

Only operate the machine when all safety devices and related safety equipment are present and operational!

Check the machine visually for any damage and defects at least once a day.

In the event of operational malfunctions the machine must be shut down immediately and secured!

Secure the work area around the machine in public areas providing a safety distance of at least 10 m (3.3 ft) from the machine.

Faults must be immediately rectified.

Carry out the switch on, and switch off operations in accordance with this user guide.

Before switching on the machine make sure that no-one can be endangered when the machine starts up.

Never operate the machine when not in its upright position.

Do not switch off or remove the exhaust and or the ventilation devices whilst the machine is running!

All persons in the proximity of the machine must wear ear and eye protection as well as safety shoes. In addition the machine operator must wear close-fitting protective clothing.

Only use extension cables that are sized and marked in accordance with the overall power consumption of the machine and the valid VDE guidelines.

3.5 Electrical safety



The power source must be equipped fuses according to the table in "2. Technical specifications". All cables used must be marked and rated according to the fuses used.

Never connect the machine to a power source that does not provide protective earth!

Work on electrical equipment may only be undertaken by a skilled electrician or by trained persons under the supervision of a skilled electrician as well as in accordance with the local electrical engineering regulations.

Use only extension cables, that are used for extending the main cable, that are sized and marked in accordance with the overall power consumption of the machine and the valid VDE guidelines.

The electrical equipment for the plant must be inspected regularly. Defects such as loose connections or scorched cables must be rectified immediately. Call a skilled electrician or out customer services.

A second person must be in attendance whilst the electrical engineer is working on the equipment.

The work area must be secured against any third party entering the work area. Follow local electrical engineering regulations while working on the machine. Never leave a machine unattended. Use only tools that are insulated against electricity.

Only start work after you are familiar with the electrical engineering regulations that apply to the local area.

Only use voltage seekers that comply with the regulations when troubleshooting. From time to time check voltage seekers to ensure that they are operationally efficient.

3.6 Noise level

The noise level of the Multistripper has been measured in accordance with ISO 3744 at 83db. at the ear of the operator. The use of ear defenders is recommended.

Abnormal noise when idle may be caused by a worn ball bearing. This should be replaced as soon as possible in order to prevent any breaking of the blade holder due to fatigue.

3.7 Vibrations

The mechanical vibration level of the machine has been measured in accordance with ISO 5349-1:2001 at Ahw=5.7 m/s. Maximum daily exposure 1.5 hours including breaks 6.2 hours.

3.8 Transportation

Transport and removal of the Multistripper can be happen in the following ways: if manually lifting the machine, it is advisable that two persons lift simultaneously. By using a ramp one person can load the machine. If lifting the machine mechanically by use of a crane.

4. Repair and maintenance

The machine should be lubricated every day, the arrows marked locations (5 places). Use a thin

machine oil or a year-round engine oil 15W-40.

5. Spare parts

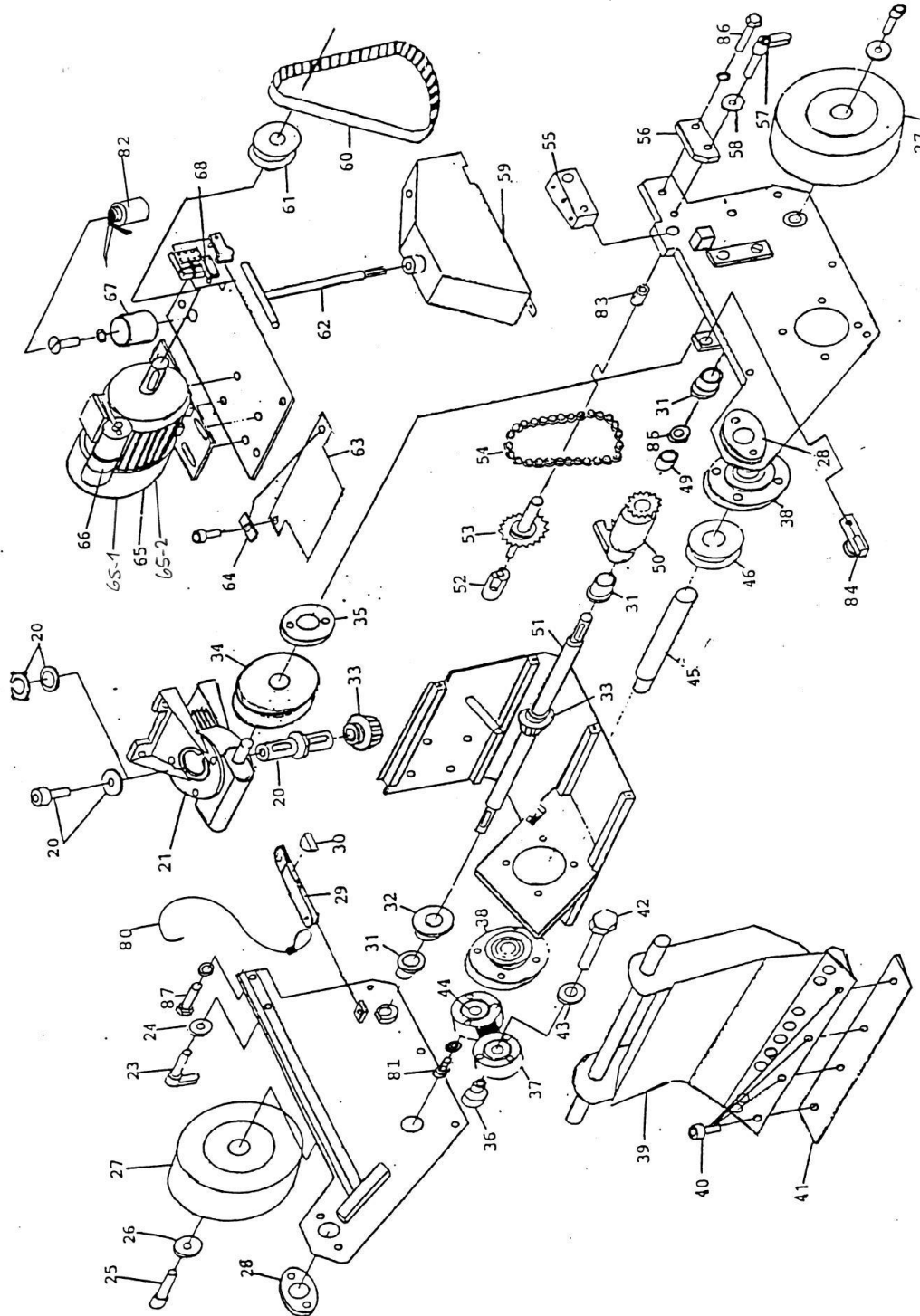

Number	Description	Number	Description
1	Connecting arm	40	Insex bolts 6x12
2	Coupling rod	41	Clamping rail
4	Pressure spring	42	Bolt for bearing shank
5	Gear glider	43	Bevel-edged washer M12
6	Gear arm	44	Bearing 6203
7	Ball knob	45	Eccentric shaft
8	Pressure spring	46	Toothed belt pulley 16 t. Ø20
9	Stop ring for pressure spring	49	Oil bronze bearing 20x25
11	Bearing block with bearing	50	Coupling screw
12	Nylon bearing 12x16x30	51	Wheel bearing
13	Gear locking plate	52	Program disc
14	Shim	53	Chain wheel 26 t.
V-15	Rubber handle	54	Chain 8 mm.
V-10-A	Vibration handle, upper	55	Gear stop
V-10-B	Vibration handle, lower	56	Backstop
V-16	Power switch CA10	57	Clamping grip M10, left
V-77	Coupling	58	Retaining washer Ø10
V-17	Cable strain relief PVC	59	Guard complete
18	Rubber cable+plug	60	Toothed belt
19	Blade magazine	61	Toothed belt pulley 16 t. Ø19
V-78	Vibration damper	62	T-key
V-79	Locking bush	63	T-plate
20	Gear shaft	64	Shim
21	Gear VF44 1:70 (-31.04.08)	65	Motor complete
21	Gear VF44 1.60 (01.05.08-)	66	Capacitor
23	Clamping grip M10, right	67	Oil can holder
24	Retaining washer Ø10	68	Micro switch
25	Insex Bolt M5x20	80	Neutral gear wire
26	Retaining washer Ø6	81	Insex bolt M5x16
27	Wheel	82	Oil can
28	Bearing SNR FD204	83	Oil bronze bearing 12x16
29	Neutral gear arm	84	Pulley holder + pulley
30	Crescent	85	Supporting disc Ø20
31	Nylon bearing 20x25 with sleeve	86	M10 bolt 50 mm.
32	Neutral gear disc	87	M10 bolt 45 mm.
33	Tapered gear wheel (pair)	90	Chain adjuster
34	Toothed belt pulley 36 t.	92	Coupling
35	Bearing SAFD204	94	Rubber splash guard
36	Bearing shank/Bushing	95	Angle plate for splash guard
37	Double bearing house		
38	Bearing SNR FCE204		
39	Front part		

6. Warranty

This product from Scanmaskin Sweden AB comes with a twelve month warranty. If the product does not function satisfactorily during this period, Scanmaskin will return the product to full working order for normal use which the product is intended for - with no charge for labor or spare parts, according to the following conditions:

1. The warranty only applies to persons that have legal right to the equipment during the warranty period.
2. The manufacturer's undertaking is limited to the repair of defective parts or the replacement of these according to the manufacturer's assessment. Costs and risks for transport as well as dismantling and reinstallation of the product / products and other direct or indirect costs, associated with the repair in question, are not covered by this warranty.
3. Periodic inspections, adjustments, maintenance work and changes are not covered by the warranty.
4. Scanmaskin is not liable for any damages to grinding discs or other similar equipment.
5. The warranty only applies to material and design deficiencies and does not apply in the following cases:
 - a. Damage caused through accidents, carelessness, changes, use of spare parts or grinding tools that are not original components, or incorrect use and installation.
 - b. Damage caused by lightning, water, fire, vandalism, incorrect mains voltage, incorrect ventilation or other causes that lie outside of the manufacturer's control.
6. Scanmaskin reserves the right to modify the design - or make improvements without obligation to change previously manufactured products.
7. All warranty repairs must be carried out by Scanmaskin or by a Scanmaskin authorized repair workshop. Costs for repairs, carried out by an unauthorized workshop, will not be reimbursed by Scanmaskin. If such repairs damage this product these are not cover by the warranty agreement.

7. EC-declaration

Declaration of conformity CE

Manufacturer JKA Maskiner

Address Heljesvägen 10
437 36 Lindome
Sweden

Product Stripper
Name Multistripper

Serialnumber _____

Standards used including number

Machine directives 2006/42/EG
EMC 2004/108/EG
LVD 2006/95/EG

Harmonized standards

Safety of machinery EN ISO 13850
Safety of machinery EN ISO 12100-1/-2
Safe Torque Off EN ISO 60204-1

Place of issue Lindome / Gothenburg / Sweden

Name of authorized representative Per-Anders Bardh
Position CEO

Declaration

We declare that as the authorized representative, the above information in relation to the supply / manufacture of this product is in conformity with the stated standards and other related documents following the provisions of EEC directives.

Signature of authorized representative:



8. Contact information

Sweden (Head Office)

Heljesvägen 10
Box 187
SE-437 22 Lindome

Phone: +46 (0) 31 99 49 70
Fax: +46 (0) 31 99 48 70
E-mail: info@scanmaskin.se
Website: www.scanmaskin.se

Denmark

Torvegade 22
DK-7330 Brande

Phone: +45 97 18 00 58
Fax: +45 97 18 45 58
E-mail: info@scanmineral.dk
Website: www.scanmaskin.se

Norway

Postboks 6, Furuset
N-1001 Oslo
Tomtveien 12
N-2015 Leisund

Phone: +47 63 87 60 00
Fax: +47 63 87 60 01
E-mail: info@scanmaskin.no
Website: www.scanmaskin.no

Finland

Raudoittajantie 3 A
FIN-06450 Porvoo / Borgå

Phone: +358 10 292 4700
E-mail: info@scanmaskin.fi
Website: www.scanmaskin.fi

USA

1407 132nd Avenue Northeast, Suite 8
Bellevue, Washington, 98005

Phone: +1 425 209 0147
E-mail: info@scanmaskin.com
Website: www.scanmaskin.com

NOTES

A series of horizontal dotted lines for taking notes.

Kära kund!

Tack för att du har valt Scanmaskin.

Vi önskar dig lycka till med din nya Multistripper Vario och hoppas att den lever upp till dina förväntningar.

Scanmaskin Sweden AB



Paulo Bergstrand
Verkställande direktör

Adress:

Scanmaskin Sweden AB
Box 187
SE-437 22 Lindome/Göteborg
Sverige

Telefon: +46 (0) 31 99 49 70

Fax: +46 (0) 31 99 48 70

www.scanmaskin.se

Viktig information!

Denna bruksanvisning behandlar endast strippern Multistripper Vario. Multistripper Vario används för att skära fastlimmade golvbeläggningmaterial (Linoleum, vinyl, heltäckningsmattor ect.) fria från underlaget.

Om Multistripper Vario används för andra ändamål eller hanteras på annat sätt än som anges i denna bruksanvisning, fransäger sig Scanmaskin Sweden AB allt ansvar.

Uppmärksamma särskilt avsnittet "2 Säkerhetsföreskrifter". Läs bruksanvisningen innan användning av Multistripper Vario. Reservdelar och blad som används med Multistripper Vario måste vara godkända av Scanmaskin Sweden AB.

Innehåll

<u>1</u>	<u>Användning</u>	31
1.1	<u>Bruksanvisning</u>	31
1.2	<u>Användning av maskin</u>	31
1.3	<u>Användning av knivar</u>	32
1.4	<u>Tekniska specifikationer</u>	33
1.5	<u>Säkerhetsföreskrifter</u>	33
<u>2</u>	<u>Underhåll och reparation</u>	34
<u>3</u>	<u>Diagram</u>	35
3.1	<u>Manöver el-diagram</u>	35
3.2	<u>Kontrollbox el-diagram</u>	36
3.3	<u>Övergripande diagram</u>	37
<u>4</u>	<u>Garanti</u>	38
<u>5</u>	<u>EU-deklaration</u>	39
<u>6</u>	<u>Kontaktinformation</u>	40

1. Användning

1.1 Bruksanvisning

Multistripper Vario används för att skära fastlimmade golvbeläggingsmaterial (Linoleum, vinyl, heltäckningsmattor ect.) fria från underlaget. Den arbetar med hjälp av en motordriven excentrisk kniv som vibreras in i limfogen. Multistripper Vario är självkörande och det är därför inte nödvändigt att pressa in i limfogen. Maskinen är utrustad med friväxel, varför maskinen kan användas manuellt för efterskrapning av beläggingsrester o.dyl. Multistripper Vario får endast användas inomhus och tål inte rengöring med högtryckstvätt (vatten), vilket medför rost på kullager och transmission.

1.2 Användning av maskin

Kontrollera alltid att kniven är vass (1) vid start, om inte skall strömmen till maskinen vara avbruten innan kniven byts ut. Kniven hålls fast av 4 skruvar med invändig sexkant. Skruvarna lossas med den nyckel (2), som finns på handtaget. Anslut strömmen till maskinen och starta den vibrerande kniven på gröna knappen (3), den svarta knappen (4) stannar maskinen ögonblickligen. Vid drift framåt ska den gröna knappen vara aktiverad och vridreglaget (5) för variabel hastighet ska vridas ned på 1, innan man aktiverar den svarta vippkontakten (6). Nu kör maskinen framåt och man kan steglöst öka hastigheten, så att man får maximal dragkraft. Om dragkraften inte är optimal, kan man öka prestationsförmågan med hjälp av extra vikt, som placeras ovanpå maskinen (7), max. 2x25 kg. Vid användning av extra vikter, ska man vara medveten om att det medför ett extra slitage, så använd vikterna med omtanke. Vid överbelastning kan en säkring i styrboxen gå sönder, den byts ut genom att följa anvisningen på boen - kom ihåg att avbryta strömmen. Styrboxen (8) får inte öppnas, säkringen (3, 15Amp.) sitter på sidan av boxen i en svart säkringshållare (9).

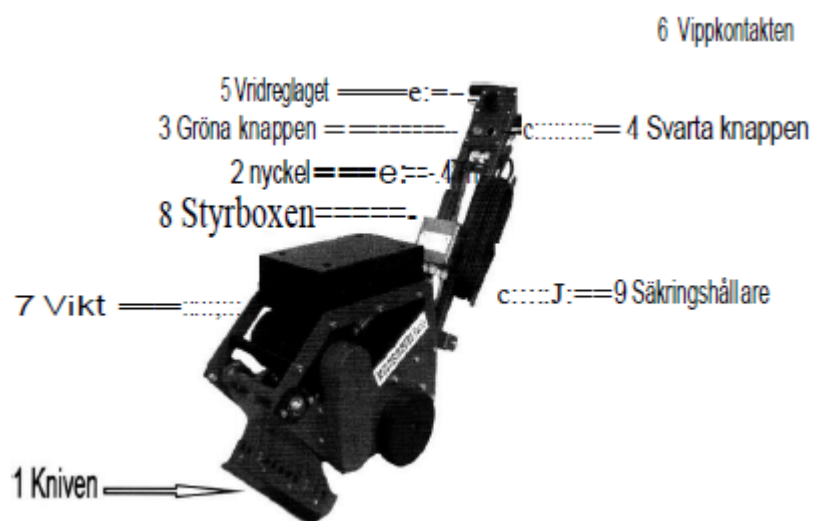

1.3 Användning av knivar

Den vanligaste kniven är normal klinga som används till alla beläggningstyper. Kräver uppskärning i strimlor vid avtagning av heltäckningsmattor. Monteras med slipfasen uppåt.

Modell 103201 Normal kniv 320 mm.

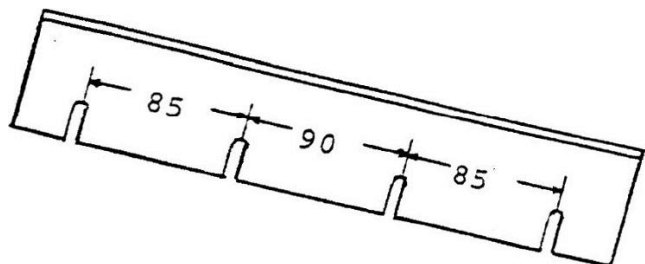

Om beläggningen är mycket svårarbetad och om kniven har en tendens att pressas över kanten och upp på beläggningen, kan den aggressiva kniven med 15 graders vinkel vara lösning.

Modell 103203 Aggressiv kniv 320 m m.

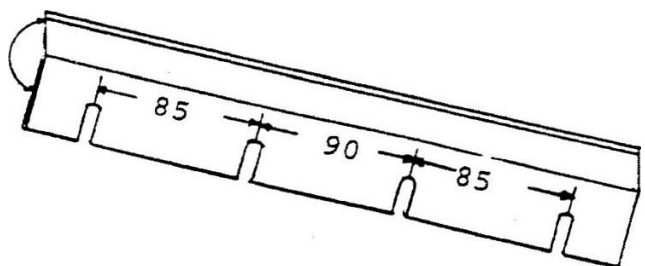

3-skärskniv med inbyggt sidoskär, kräver inte uppskärning i strimlor. Används till alla beläggningar, dock mindre passande till heltäckningsmattor vävda med öglor. Vid mycket hårt fastsittande beläggningar kan bredden på strimlorna ändras till 2/3 eller 1/2 bredd utan stopp, vilket i praktiken är mycket användbart.

Modell I 03202 3-skärskniv 355 mm.

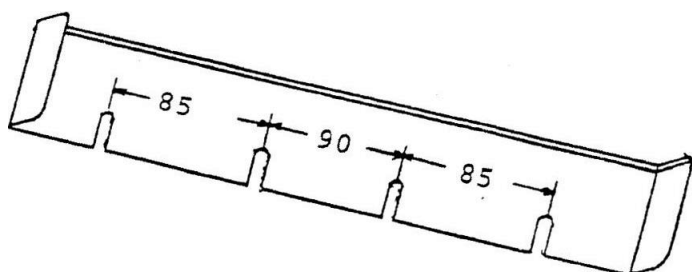

1.4 Tekniska specifikationer

Multistripper Vario är försedd med 2 motorer.

Motor 1: AC Normmotor ytkyld, 220 v. 550 watt. 2800 o/min. (drift av kniv).

Motor 2: DC Motor-ytkyld, 180 v. 440 watt. 1000-3000 o/min. (framdrift). El: Strömbrytare med nollspänningssäkring och överbelastningssäkring.

Koppling: Elektromagnetisk 105 v.

Kniv: Pendelupphängd, knivbredd 32 cm. Viktklossar: 25 kg. (Max extravikt 2x25 kg.) Mått och vikt: Höjd 90 cm.

Bredd 32 cm.

Längd 100 cm.

Vikt 86 kg.

CE märkningsskylt

1.5 Säkerhetsföreskrifter

Multistripper Vario får endast användas inomhus till pålimmade golvbeläggningsskivor och inte på papptak utomhus eller liknande. Garantin bortfaller vid denna typ av användning.

Avbryt alltid strömmen vid byte av knivar eller andra typer av driftstopp. Maskinen är Utrustad med nollspänningssäkring som garanterar att strömmen bryts automatiskt om nätspänningen skulle falla och maskinen startar inte när spänningen kommer tillbaka.

Multistripper Vario 's bullernivå är uppmätt enligt ISO 3744 till 83 db, vid operatörens öra. Användning av hörselskydd rekommenderas.

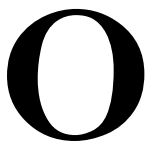

Maskinens vibrationsnivå är uppmätt enligt ISO 5349-1 :200 ltil Ahw=5 ,7 m/s Maximal daglig belastning 1,5 timmar, inkl. Pauser 6,2 timmar

Onormalt buller utan att maskinen belastas kan orsakas av att kullagren är slitna och dessa bör då bytas ut så snart som möjligt för att undgå ett brott på knivhållaren.

Transport och bogsering av Multistripper Vario kan ske på följande sätt: Vid manuellt lyft rekommenderas att två personer lyfter samtidigt. Vid användning av ramp kan en person lasta maskinen. Vid mekaniskt lyft med kran, kan man montera lyftbygel (tillbehör).

2. Underhåll och reparation

Multistripper Vario kräver inget särskilt underhåll av användaren.

Maskinen är försedd med oljebronslager och fettsmorda rullkedjor, som är särskilt användbara i maskinens dagliga miljö. DC motorn för framdrift är försedd med kol som ska bytas ut för varje ca. 2000 drifttimmar, annars kan det uppstå driftstopp och skadad motor.

Det är att rekommendera att sända maskinen till service varje 1-2 år för spänning av kedjor, kontroll av kul lager, växel och motorer.

För problemfri avskalning, ska man säkra att knivhållaren är rengjord och att M6x12 bultarna är ok. Hjulen ska vara lika stora och rengjorda annars skalas det av snett.

Vid reparation och service av Multistripper Vario är det lämpligt att producenten utför arbetet på maskinen. Vid reparation på en inte auktoriserad verkstad bortfaller garantin.

3. Diagram

3.1 Manöver el-diagram

MULTISTRIPPER VARIO MANEUVER DIAGRAM

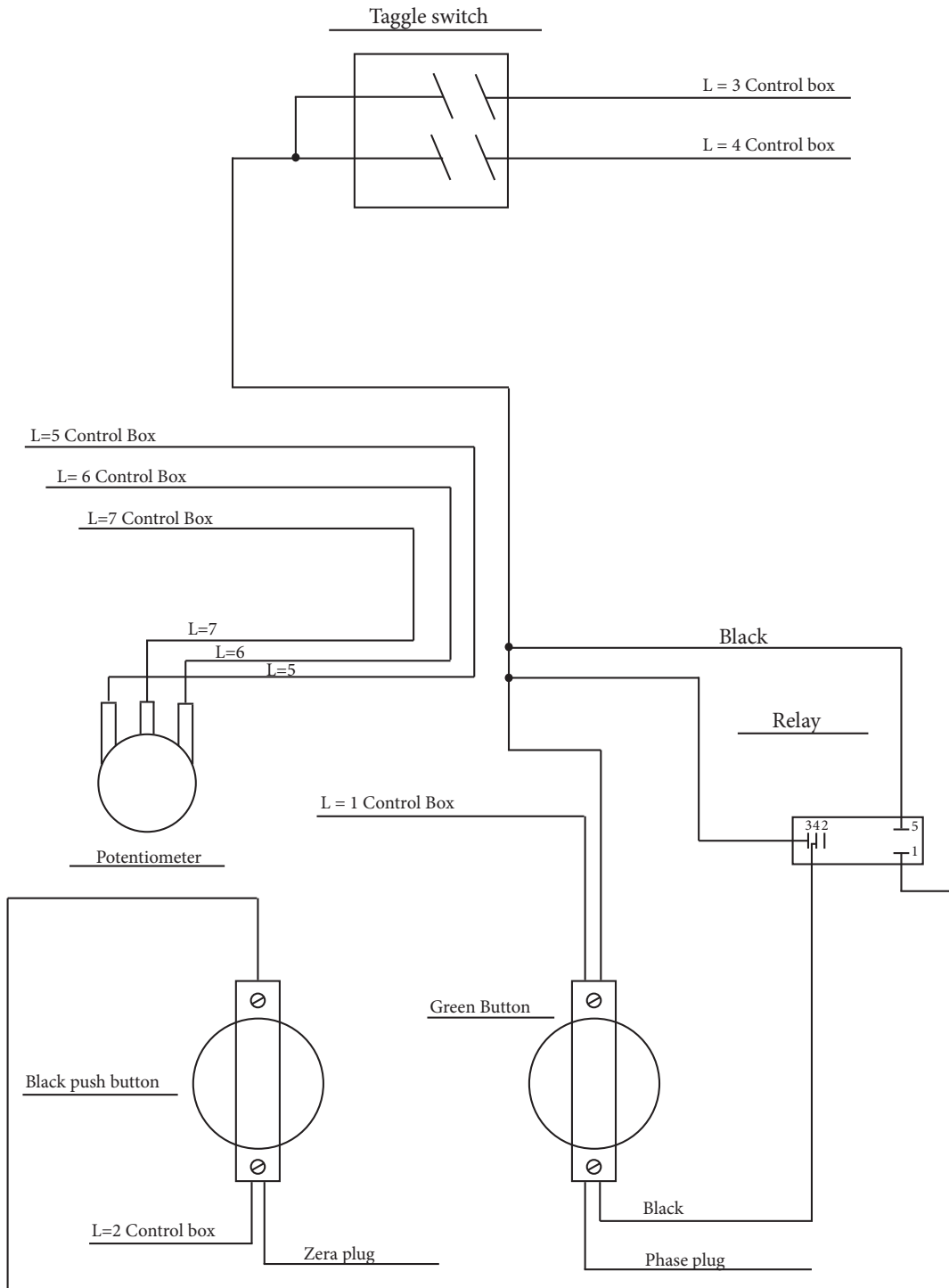

3.2 Kontrollbox el-diagram

MULTISTRIPPER VARIO CONTROL BOX / PRINT CIRCUIT DIAGRAM

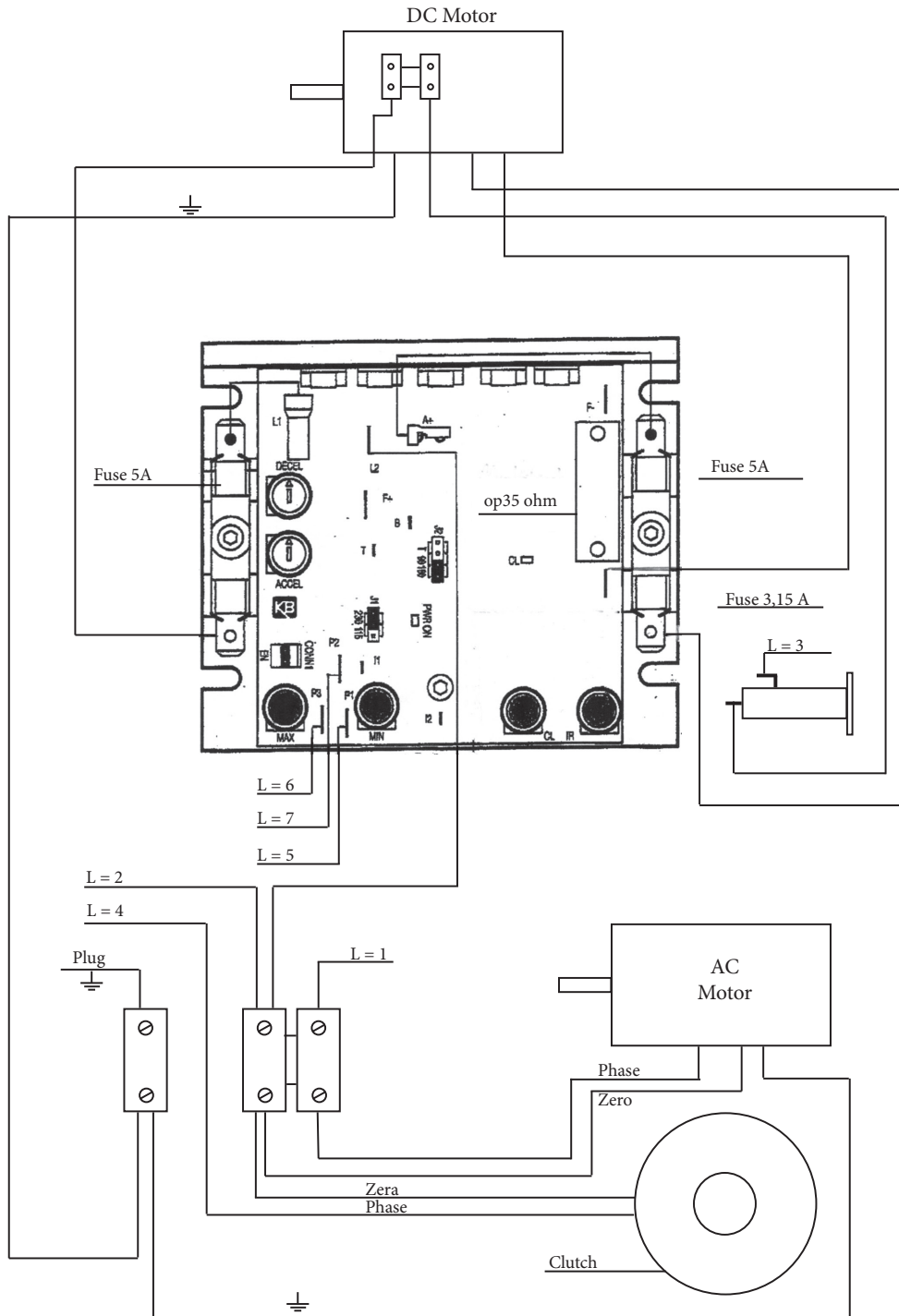

3.3 Övergripande diagram

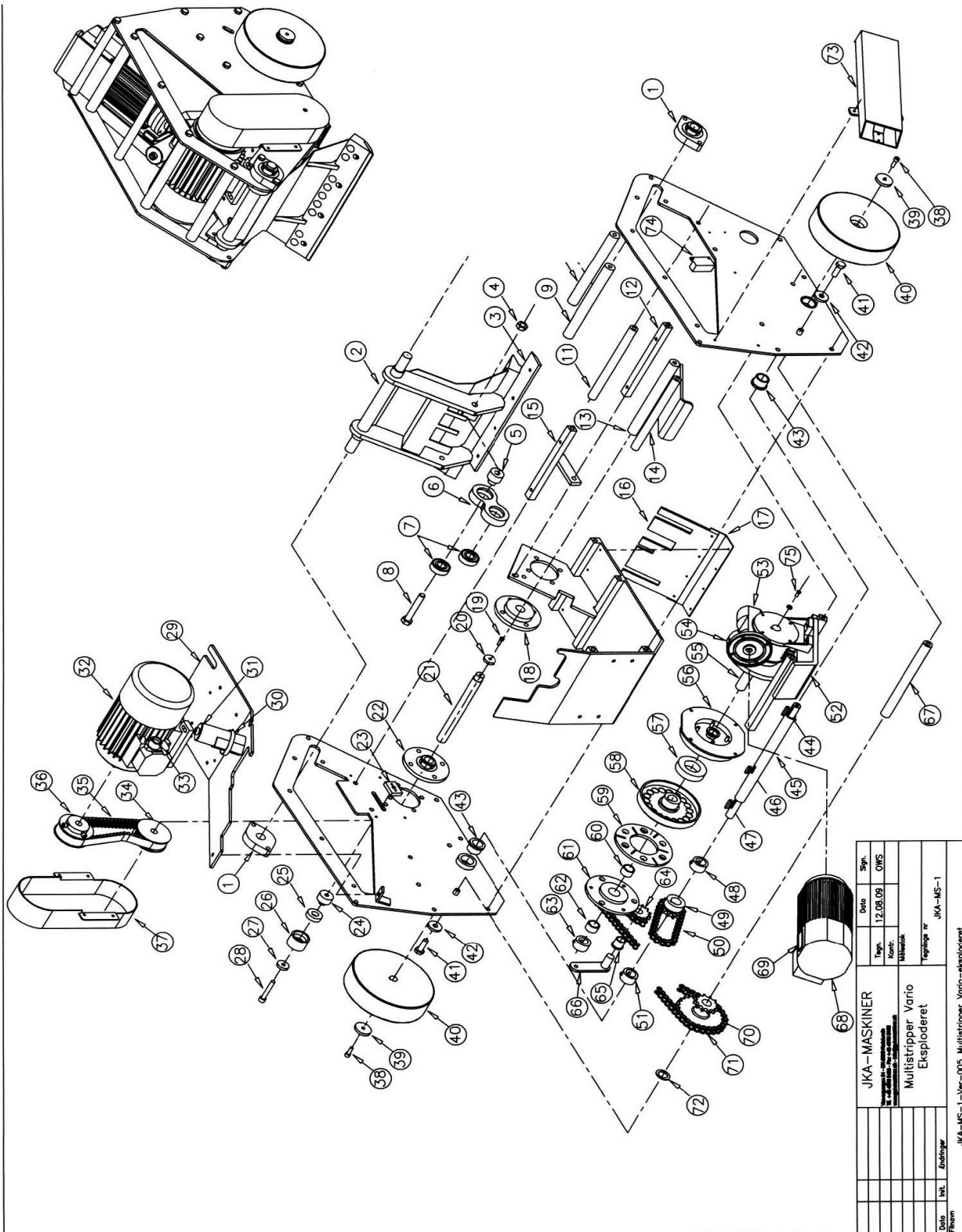

JKÅ-MASKINER		Dato	Syn.
JKÅ-MASKINER AB		12.08.09	OVS
Multistripper Vario		Modell	Multistripper
Eksploderet		Beställningsnr	JKÅ-MS-1
JKÅ-MS-1-Var-005 Multistripper Vario-eksploderet			
Utg.	Inh.	Eksploderet	
Blom			

4. Garanti

Denna produkt från Scanmaskin Sweden AB levereras med tolv månaders garanti. Om produkten inte fungerar tillfredsställande under denna period, kommer Scanmaskin att återställa produkten till fullt fungerande skick för den användning produkten är avsedd för, utan kostnad för arbete eller reservdelar, enligt följande villkor:

1. Garantin gäller endast för personer som har lagstadgad rätt till utrustningen under garantiperioden.
2. Tillverkarens ansvar är begränsat till reparation av defekta delar eller byte av dessa delar enligt tillverkarens bedömning. Kostnader och risker för transporter samt demontering och ominstallation av produkten/produkterna och andra direkta eller indirekta kostnader relaterade till reparationen i fråga, täcks inte av denna garanti.
3. Regelbundna kontroller, justeringar, underhållsarbete och förändringar ingår inte i garantin.
4. Scanmaskin ansvarar inte för skador på slipskivor eller annan liknande utrustning.
5. Garantin gäller endast för fel på material och konstruktion och gäller inte i följande fall:
 - a. Skada orsakad av olyckor, vårdslöshet, förändringar, användning av icke-original reservdelar eller slipverktyg, samt felaktig användning eller installation.
 - b. Skada orsakad av blixtnedslag, vatten, eld, skadegörelse, felaktig nätspänning, felaktig ventilation eller andra orsaker som ligger utanför tillverkarens kontroll.
6. Scanmaskin förbehåller sig rättigheten att ändra konstruktionen eller att genomföra förbättringar utan skyldighet att uppdatera tidigare tillverkade produkter.
7. Alla garantireparationer ska utföras av Scanmaskin eller av en verkstad som är auktoriserad av Scanmaskin. Kostnader för reparationer som har utförts av en oauktorerad verkstad kommer inte att ersättas av Scanmaskin. Om sådana reparationer skadar produkten täcks dessa skador inte av garantin.

5. EU-deklaration

Försäkran om CE-överensstämmelse

Tillverkare	Scanmaskin Sweden AB
Adress	Heljesvägen 10 427 36 Lindome/Göteborg Sverige
Produkt	Stripper
Produktnamn	Multistripper Vario
Serienummer	_____

Produkten uppfyller följande EU-riktlinjer

Maskindirektiv	2006/42/EG
EMC	2004/108/EG
LVD	2006/95/EG
Harmoniserade standarder	EN ISO 13850 EN ISO 12100-1/-2 EN ISO 60204-1
Utfärdandeplats	Lindome/Göteborg/Sverige
Auktoriserad representant	Paulo Bergstrand Verkställande direktör

Scanmaskin Sweden AB

2019-01-01



Paulo Bergstrand
Verkställande direkt

6. Kontaktinformation

Sverige Huvudkontor

Heljesvägen 10
Box 187
SE-437 22 Lindome

Telefon: +46 (0) 31 99 49 70
Fax: +46 (0) 31 99 48 70
E-post: info@scanmaskin.se
Hemsida: www.scanmaskin.se

Danmark

Torvegade 22
DK-7330 Brande

Telefon: +45 97 18 00 58
Fax: +45 97 18 45 58
E-post: info@scanmineral.dk
Hemsida: www.scanmaskin.se

Norge

Maridalsveien 91
NO-0461 Oslo

Telefon: +47 -63 87 60 00
Fax: +47 -63 87 60 01
E-post: info@scanmaskin.no
Hemsida: www.scanmaskin.no

Finland

Raudoittajantie 3A
FIN-06450 Porvoo / Borgå

Telefon: +358 10 292 4700
E-post: info@scanmaskin.fi
Hemsida: www.scanmaskin.fi

USA

18868 72nd AVE S
WA-98032 KENT

Phone: +1 425 209 0147
E-mail: info@scanmaskin.com
Hemsida: www.scanmaskin.com

Dear Customer!

Thank you for choosing Scanmaskin as your supplier.

We wish you all the best with your new Multistripper Vario and hope that it meets your expectations.

Scanmaskin Sverige AB



Paulo Bergstrand
Managing Director

Address:
Scanmaskin Sweden AB
Box 187
SE-437 22 Lindome / Gothenburg
Sweden

Telephone: +46 (0) 31 99 49 70

Fax: +46 (0) 31 99 48 70

www.scanmaskin.com

Important Information!

This Manual only concerns the stripper "**Multistripper Vario**" approved by Scanmaskin Sweden AB.

If **Multistripper Vario** is used for other purposes or handled in ways other than that described in this Manual, Scanmaskin Sweden AB disclaims all responsibility.

Especially note the section "3. Safety instructions". Read the Manual before using the stripper Multistripper Vario. The spare parts and blades used on Multistripper vario must be approved by Scanmaskin Sweden AB.

Table of content

1	User guide for operator.....	45
1.1	Choice of blade	45
2	Technical specification.....	46
3	Safety instructions	46
3.1	Safety precautions.....	46
3.2	Organizational measures.....	46
3.3	Personnel selection and qualification.....	48
3.4	Safety regarding operation of machine.....	48
3.5	Electrical safety.....	49
3.6	Noise level.....	49
3.7	Vibrations.....	50
3.8	Transportation.....	50
4	Repair and maintenance.....	50
5	Spare parts	51
6	Warranty	58
7	EU-declaration	59
8	Contact information	60

1. User guide for operator

The Multistripper Vario is used to cut loose glued down flooring materials (Lina, Vinyl, carpet etc.) from the underlay. It works by means of a blade that by eccentric drive vibrates into the glue joint. The Multistripper Vario is self-propelled and it is not necessary to force into the glue joint. The machine is equipped with neutral gear allowing it to be used manually for removal of left-over flooring material etc. The Multistripper Vario is for indoor use only and must not be cleaned by use of a high-pressure cleaner (water). This will lead to corrosion of the ball bearings and the transmission. When starting up always check that the blade is sharp (1), if not, the power supply for the machine must be switched off before changing the blade. The blade is mounted by use of 4 Unbrako socket screws. The screws are loosened with the Allen key (2) by the handle. Switch on the power supply and start the vibrating blade by pushing the green control button (3), pushing the black control button (4) will stop the machine immediately. To engage the propulsion, the green push button must be engaged and the black speed regulator that adjusts the speed is set on 1, before activating the black rocker switch (6). Now the machine moves forward and the speed is infinitely variable to provide for maximum traction. If traction is not optimum, an additional weight block can be placed on top of the machine (7), maximum 2*25kg, to increase its efficiency. Please note that attaching additional weight blocks will increase wear and tear, so use the weight blocks sparingly. In case of overload, the fuse in the control box may blow; it can be replaced by following the instructions on the box. The control box (8) must not be opened; the fuse (3.15 amp.) is placed in the black fuse carrier (9) on the side of the box.

1.1 Choice of blade

The most common blade is the Normal blade used on all types of flooring material. It is necessary to cut the carpet into long pieces before use. Mounted with bevel facing upwards.

Normal blade 320 mm.

If the flooring material is difficult to remove and the blade has a tendency to slip, the Aggressive blade with a 15-degree bend may be the solution.

Aggressive blade 320 mm.

The three- edged blade with self-scoring corners. No need to pre-cut carpet into long pieces. It can be used on all flooring materials, however, not suitable for use on loop carpets. When removing flooring materials that are particularly difficult to remove, the width of the cut can be adjusted without stopping to 2/3 or 1/2. This is very useful.

Three- edged blade

2. Technical specification

The Multistripper Vario is equipped with 2 motors:

Motor 1: AC standard motor, surface cooled, 220 volts, 550-watt, 2800 rpm (operating the blade)

Motor 2: DC Motor, surface cooled, 180 volts 440 watt.

Variable speed regulation: 1000-3000 rpm (propulsion)

Electricity: Breaker with a no voltage release switch and overload circuit breaker

Clutch: Electro- magnetic 105 volts

Blade: Rocker-mounted, blade width 32 cm

Weight blocks: 25kg (maximum extra weight 2*25kg)

Measurements:

Height: 90 cm

Width: 32 cm

Length: 100 cm

Weight: 86 kg

CE sign

3. Safety instructions

The Multistripper Vario is only for indoor use on glued down flooring materials, not for use on outdoor roofing felt or the like, the Warranty will cease to apply in this case.

Always unplug from the main power supply when changing the blade or when not in use. The machine is equipped with a no voltage release switch. In case of loss of mains voltage, it ensures that the power is cut off and that the machine does not start once mains voltage is back on.

3.1 Safety precautions



Any machine, if it is not used according the regulations, may be hazardous for operating, setting-up and service personnel. The operating authority is responsible for compliance with the safety regulations during operation and maintenance, and for the use of safety devices supplied with the machine, as well as the provision of appropriate additional safety devices!

Eye and ear protection must be worn at all times.

Never operate the machine when it's not in its upright position.

Make sure there is no debris in the work area.

Check the work area for screws or other hard objects in the concrete. Don't use the machine if there are any foreign objects stuck into the surface. Such objects must be removed prior to operation of machine.

3.2 Organizational measures

The user guide is to be kept near the location where the machine is being operated and must be within reach at all times.

In addition to this user guide general and legal regulations regarding accident prevention and environmental protection must be complied with as per local regulations.

Such duties may, for example, relate to the handling of hazardous substances, or to the provision and wearing of personal protection equipment, as well as compliance with traffic regulations.

The user guide must be supplemented by other instructions, including the duty to supervise and report incidents relating to particular working practices, for example work organization, work procedures and personnel safety.

Personnel entrusted with working with the machine must read the User Guide before starting work, in particular the "3 Safety Regulations" chapter. To read these instructions after work is commenced is too late. This particularly applies to incidental activities such as setting up the equipment, carrying out maintenance work or training staff to work with the machine.

From time to time the working practices of the operators are to be checked by a supervisor especially to the items regarding awareness of safety and hazards.

Operators must tie back long hair, and not wear loose clothing or jewelry including rings. There is a risk of injury through items getting caught, or being drawn into moving machinery.

Eye and ear protection must be worn at all times!

Use personnel protection equipment if necessary or required by local regulations! Take notice of all safety and hazard notices on the machine!

All safety and hazard notices at or on the machine must be kept complete and legible!

If safety-critical changes occur to the machine or its working method, the machine must be shut down immediately! The cause of the fault must be established, and rectified.

Changes, add-ons or conversation to the machine, which might impair safety, must not be made, without the manufacturer's permission!

This applies in particular to the fitting and adjustment of safety devices.

Spare parts must comply with the technical requirements specified by the manufacturer. This is always guaranteed if original spare parts are used.

Intervals for recurring checks and inspections specified in this User Guide must be complied with!

To perform maintenance work correctly it is imperative to be equipped with the proper tools for the task in question.

Repairs may only be made by Scanmaskin Sweden AB certified service technicians.

Some work may generate sparks under certain circumstances. Personnel working with the machine must therefore be aware of the risk of fire and how to handle a fire situation properly.

Do not use the machine in areas with highly flammable and/or explosive materials.

3.3 Personnel selection and qualification

Fundamental duties:

- Work with the machine may only be undertaken by trained personnel.
- Specify clearly the responsibilities of personnel for operation, setting up, servicing and maintenance work!
- Make sure that only authorized personnel operate or work with the machine!
- Define responsibilities of the machine operator, with regard to traffic safety regulations, and inform him not to take instructions from third parties who may not be complying with the local safety requirements.
- Personnel, who are being trained to operate equipment, may only use the machine under constant supervision of an experienced person!
- Work on electrical equipment may only be undertaken by a skilled electrician or by trained persons under the supervision of a skilled electrician, as well as in accordance with the local electrical engineering regulations.

3.4 Safety regarding operation of machine



Do not allow any method of working that impairs safety!

Recognized official procedures have to be used to ensure the machine is operated in safe and best conditions.

Only operate the machine when all safety devices and related safety equipment are present and operational!

Check the machine visually for any damage and defects at least once a day.

In the event of operational malfunctions the machine must be shut down immediately and secured!

Secure the work area around the machine in public areas providing a safety distance of at least 10 m (3.3 ft) from the machine.

Faults must be immediately rectified.

Carry out the switch on, and switch off operations in accordance with this user guide.

Before switching on the machine make sure that no-one can be endangered when the machine starts up.

Never operate the machine when not in its upright position.

Do not switch off or remove the exhaust and or the ventilation devices whilst the machine is running!

All persons in the proximity of the machine must wear ear and eye protection as well as safety shoes. In addition the machine operator must wear close-fitting protective clothing.

Only use extension cables that are sized and marked in accordance with the overall power consumption of the machine and the valid VDE guidelines.

3.5 Electrical safety

The power source must be equipped fuses according to the table in "2. Technical specifications". All cables used must be marked and rated according to the fuses used.

Never connect the machine to a power source that does not provide protective earth!

Work on electrical equipment may only be undertaken by a skilled electrician or by trained persons under the supervision of a skilled electrician as well as in accordance with the local electrical engineering regulations.

Use only extension cables, that are used for extending the main cable, that are sized and marked in accordance with the overall power consumption of the machine and the valid VDE guidelines.

The electrical equipment for the plant must be inspected regularly. Defects such as loose connections or scorched cables must be rectified immediately. Call a skilled electrician or out customer services.

A second person must be in attendance whilst the electrical engineer is working on the equipment.

The work area must be secured against any third party entering the work area. Follow local electrical engineering regulations while working on the machine. Never leave a machine unattended. Use only tools that are insulated against electricity.

Only start work after you are familiar with the electrical engineering regulations that apply to the local area.

Only use voltage seekers that comply with the regulations when troubleshooting. From time to time check voltage seekers to ensure that they are operationally efficient.

3.6 Noise level

The noise level of the Multistripper Vario has been measured in accordance with ISO 3744 at 83db. at the ear of the operator. The use of ear defenders is recommended.

Abnormal noise when idle may be caused by a worn ball bearing. This should be replaced as soon as possible in order to prevent any breaking of the blade holder due to fatigue.

3.7 Vibrations

The mechanical vibration level of the machine has been measured in accordance with ISO 5349-1:2001 at $A_{hw}=5.7$ m/s. Maximum daily exposure 1.5 hours including breaks 6.2 hours.

3.8 Transportation

Transport and removal of the Multistripper Vario can be happen in the following ways: if manually lifting the machine, it is advisable that two persons lift simulate onerously. By using a ramp one person can load the machine. If lifting the machine mechanically by use of a crane, lifting brackets can be attached. (Accessories).

4. Repair and maintenance

The Multistripper Vario does not require any particular maintenance by the user. The machine is equipped with oil impregnated bronze bearings and greased roller chains which are very suitable for the daily environment of the machine. The DC motor (propulsion) is equipped with carbon brushes which must be replaced every 2000 hours of operation. If not, it will result in damage to the motor and the machine will stop functioning.

It is advisable to have the machine serviced every 1-2 years, to tighten chains, inspect bearings, gears and motors.

To facilitate scraping ensure that the blade holder is clean and that the M6x12 belts are ok. The wheels must be of equal size and clean otherwise the scraping will be uneven.

For repairs it is advisable that these be undertaken by the manufacturer. If unauthorized repairs are carried out, the warranty will cease to apply.

5. Spare parts

MULTISTRIPPER VARIO MANEUVER DIAGRAM

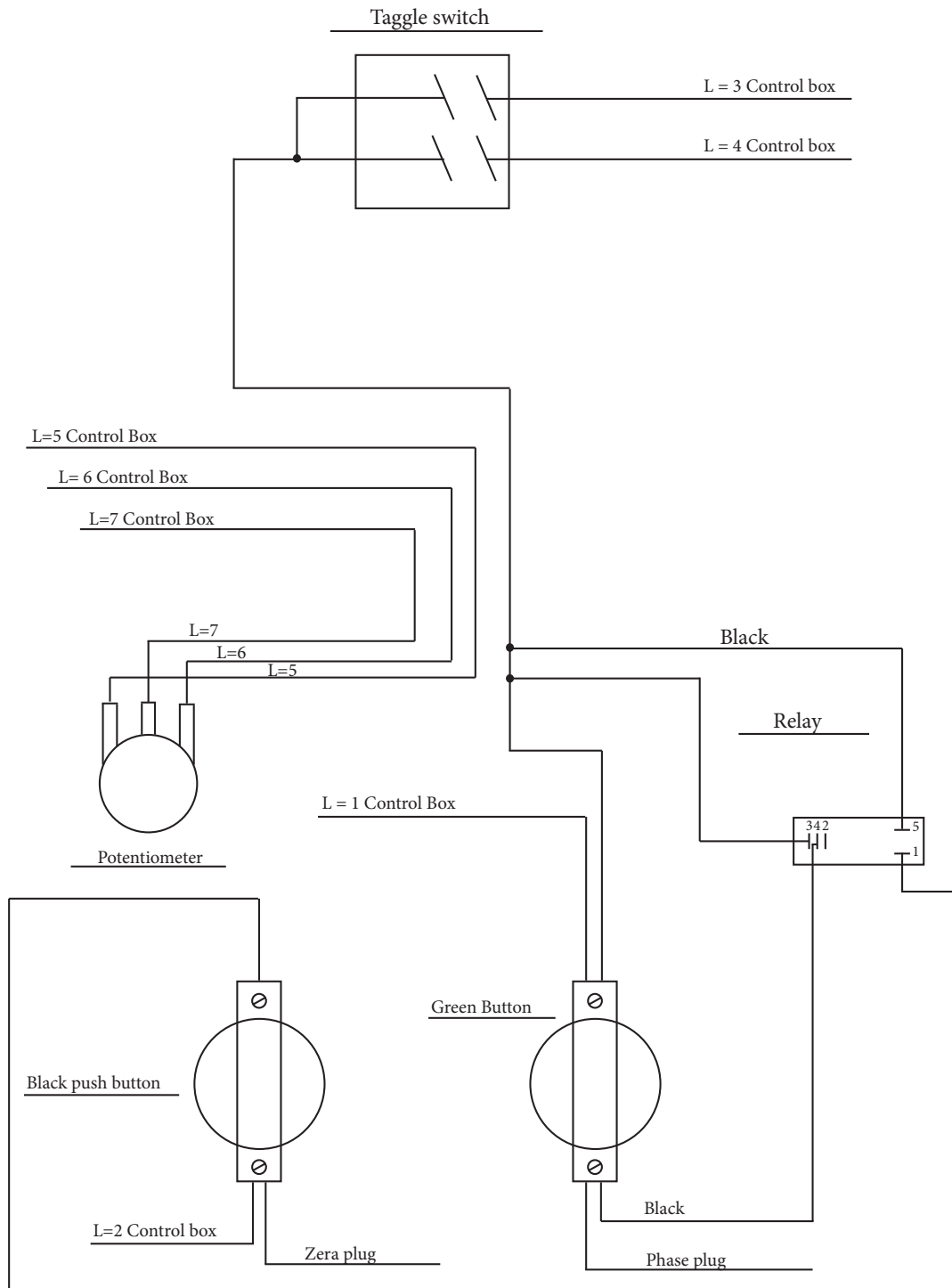

MULTISTRIPPER VARIO CONTROL BOX / PRINT CIRCUIT DIAGRAM

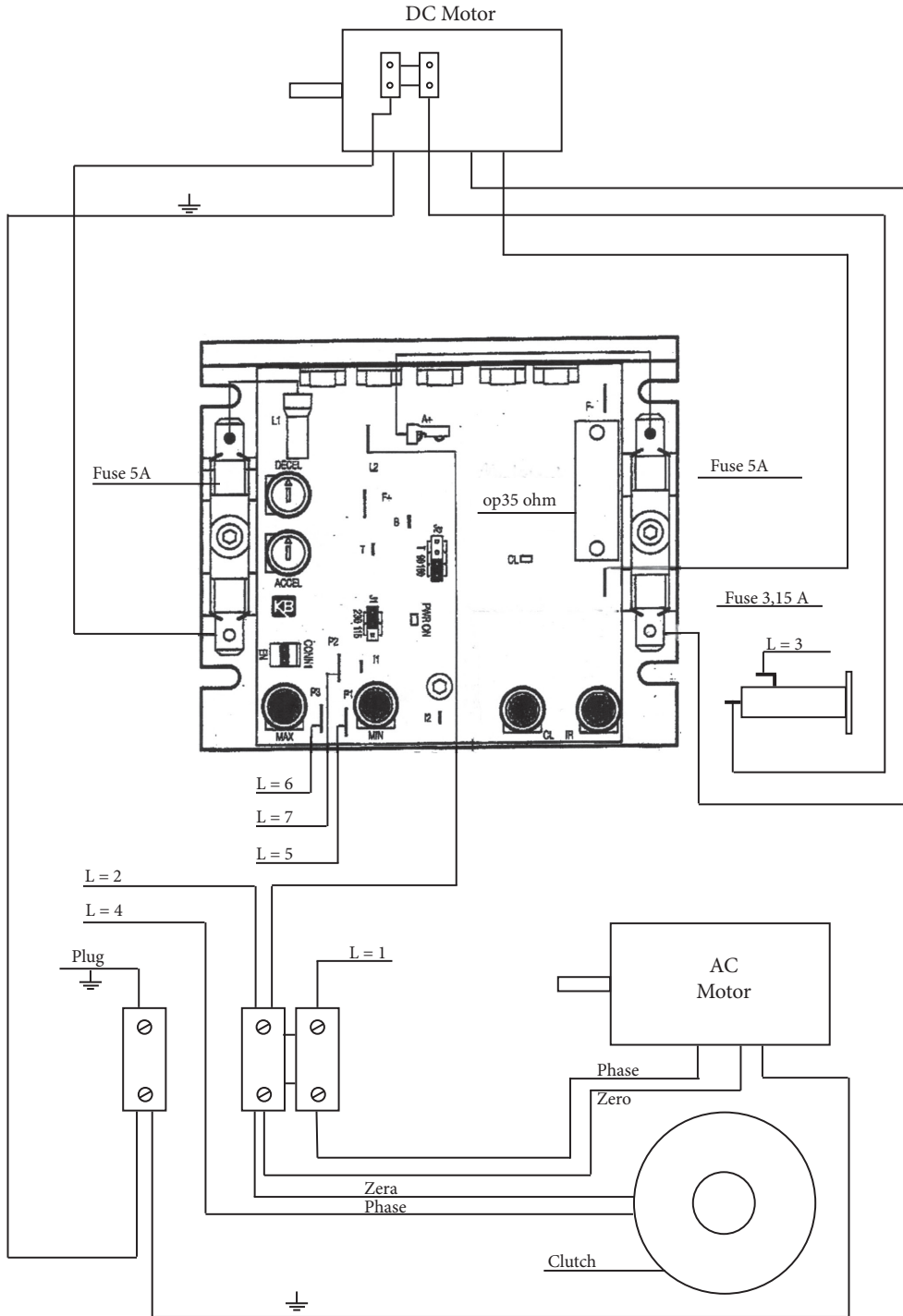

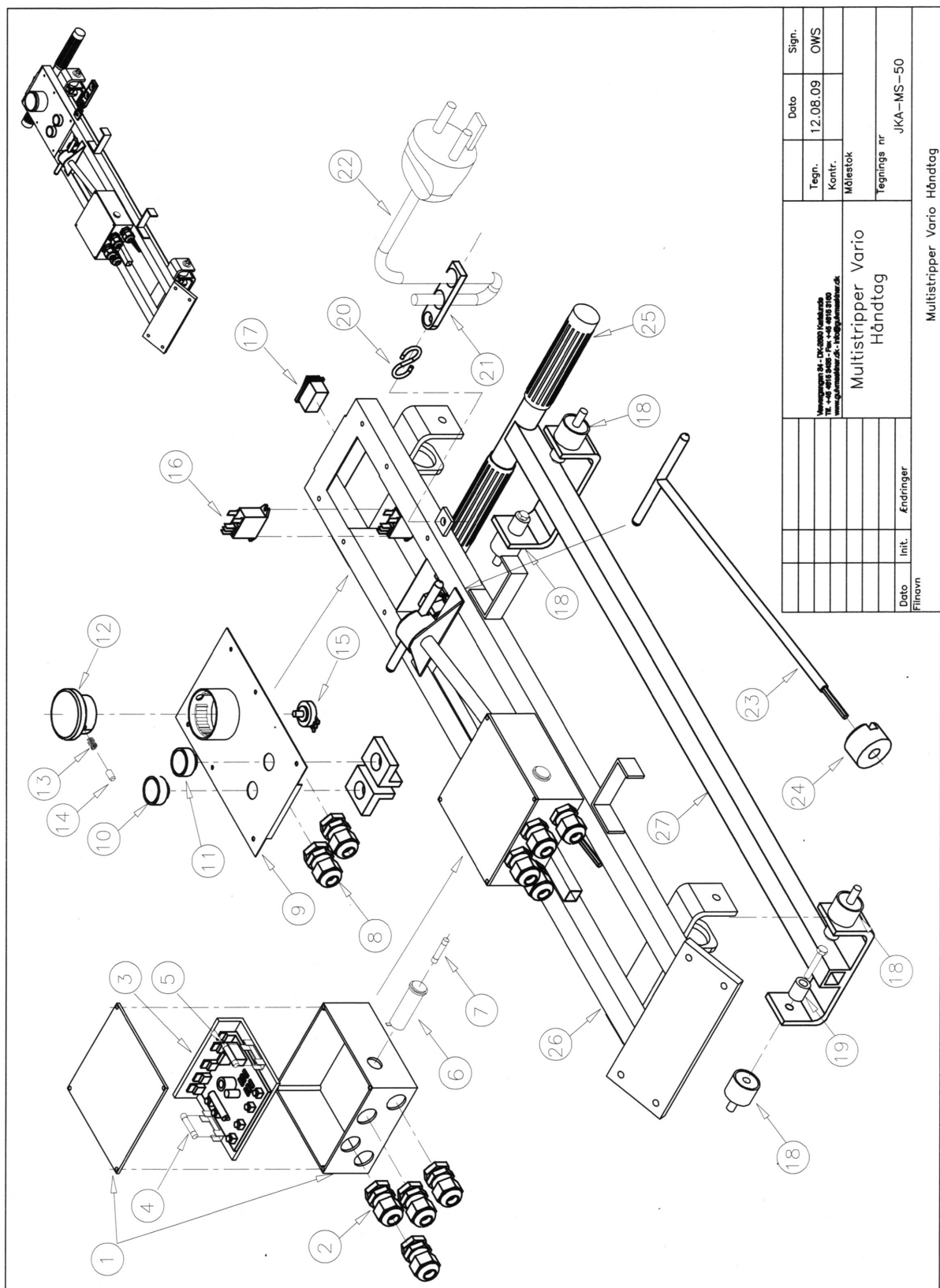

Tegning nr Multistripper Vario Håndtag		Dato 12.08.09		Sign. OWS	
Tegnings nr JKA-MS-50		Målestok		Kontr.	
Filnavn Multistripper Vario Håndtag		Endringer		Init.	
Hønsagervej 44, DK-2630 Vedbæk Tel: +45 4473 3400 / Fax: +45 4473 3100 www.gammelmotor.dk / H@Gammelmotor.dk					

Number	Description
1	Alu box
2	Coupling + nut M20
3	Motor control KBMM 225
4	Fuse 5A
5	Fuse 5A
6	6 Fuse block
7	Fuse 3,15A
8	Coupling + nut M20
9	Electrical cover
10	Push button, start
11	Push button, stop
12	Turntable
13	Spring
14	Pin
15	Potentiometer
16	Relay
17	Toggle switch
18	Rubber damper
19	Locking bush
20	S-hook
21	Cable strain relief PVC
22	Cable + plug
23	T-key
24	Key holder, rubber
25	Handle, rubber
26	Handle (Front)
27	Handle (back)

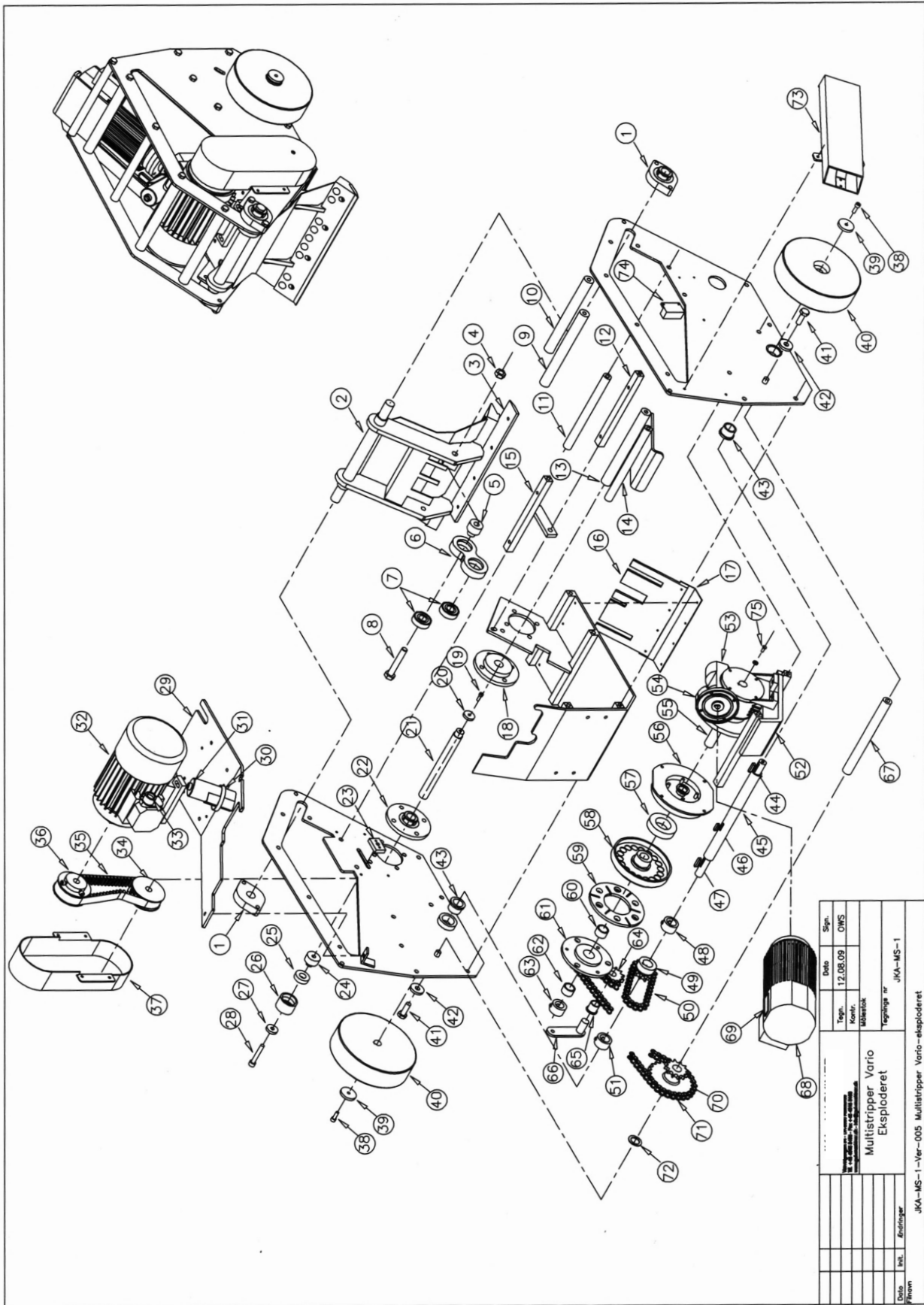

Date:		Date:	
From:	to:	Sign.	Sign.
		12.08.09	OWS
Name:		Name:	
Multistripper Vario		Mantel	
Eksploderet		Kopieret af JKA-MS-1	
JKA-MS-1 - Ver-005 Multistripper Vario-eksploderet			

Number	Description	Number	Description
1	Bearing SNR FD204	29	Top plate
2	Front part	30	Clamping strap
3	Clamping rail	31	Capacitor 25uf
4	M12 Nut	32	Motor 0,55 kw
5	Bearing shank	33	Coupling
6	Bearing housing (6203)	34	Toothed belt pulley 26 td. Ø20
6	Bearing housing (6303)	35	Toothed belt HTD600 8M20
7	Bearing 6203 2 RS	36	Toothed belt pulley 26 td. Ø14
7	Bearing 6303 2 RS	37	Guard for toothed belt
8	Bolt M12x75	38	Insex bolt M6x18
9	Round rod with plastic	39	Disc Ø6
10	Round rod	40	Wheel
11	Round rod	41	Bolt M10x30
12	16x16 stay	42	Disc Ø10
13	Round rod with plastic	43	Bronze bushing
14	Motor cover casing	44	Wedge 5x5x25
15	16x16 stay	45	Wheel shaft
16	Rubber splash guard	46	Wedge 6x6x20
17	Angle plate for splash guard	47	Wedge 5x5x25
18	Bearing SNR FCE204	48	Stop ring
19	Insex bolt M5x16	49	Chain wheel 12 td.
20	Retaining washer	50	Chain wheel 12 td.
21	Eccentric shaft	51	Stop ring
22	Bearing SNR FCE204	52	Gear bed plate
23	Disc for belt tightener	53	Gear VF44 1:60
24	Bearing shank for belt tightener	54	Gear flange
25	Bearing 6002 2 RS	55	Gear shaft
26	Pulley for belt tightener	56-58-59	Coupling
27	Disc Ø8	57	Bearing 6007 2 RS
28	Insex bolt M8x50	60	Bronze bushing 20x25

Number	Description
61	Coupling flange 12 td.
62	Bronze bushing 20x25
63	Stop ring
64	Chain adjuster wheel 12 td.
65	Nylon bushing 20x20x16
66	Chain adjuster
67	Intermediate shaft Ø20
68	Motor 0,44 kw
69	Carbon for motor (Set)
70	Chain
71	Chain wheel 25/12 td.
72	Nylon disc
73	Blade magazine
74	Rectifier
75	Insex bolt M5X16

6. Warranty

This product from Scanmaskin Sweden AB comes with a twelve month warranty. If the product does not function satisfactorily during this period, Scanmaskin will return the product to full working order for normal use which the product is intended for - with no charge for labor or spare parts, according to the following conditions:

1. The warranty only applies to persons that have legal right to the equipment during the warranty period.
2. The manufacturer's undertaking is limited to the repair of defective parts or the replacement of these according to the manufacturer's assessment. Costs and risks for transport as well as dismantling and reinstallation of the product / products and other direct or indirect costs, associated with the repair in question, are not covered by this warranty.
3. Periodic inspections, adjustments, maintenance work and changes are not covered by the warranty.
4. Scanmaskin is not liable for any damages to grinding discs or other similar equipment.
5. The warranty only applies to material and design deficiencies and does not apply in the following cases:
 - a. Damage caused through accidents, carelessness, changes, use of spare parts or grinding tools that are not original components, or incorrect use and installation.
 - b. Damage caused by lightning, water, fire, vandalism, incorrect mains voltage, incorrect ventilation or other causes that lie outside of the manufacturer's control.
6. Scanmaskin reserves the right to modify the design - or make improvements without obligation to change previously manufactured products.
7. All warranty repairs must be carried out by Scanmaskin or by a Scanmaskin authorized repair workshop. Costs for repairs, carried out by an unauthorized workshop, will not be reimbursed by Scanmaskin. If such repairs damage this product these are not covered by the warranty agreement.

7. EU-declaration

Declaration of conformity CE

Manufacturer JKA Maskiner

Address Heljesvägen 10
437 36 Lindome
Sweden

Product Name Stripper
Multistripper Vario

Serialnumber _____

Standards used including number

Machine directives 2006/42/EG
EMC 2004/108/EG
LVD 2006/95/EG

Harmonized standards

Safety of machinery EN ISO 13850
Safety of machinery EN ISO 12100-1/-2
Safe Torque Off EN ISO 60204-1

Place of issue Lindome / Gothenburg / Sweden
Name of authorized representative Paulo Bergstrand
Position Managing Director

Declaration

We declare that as the authorized representative, the above information in relation to the supply / manufacture of this product is in conformity with the stated standards and other related documents following the provisions of EEC directives.



Signature of authorized representative:

8. Contact information

Sweden (Head Office)

Heljesvägen 10
Box 187
SE-437 22 Lindome

Phone: +46 (0) 31 99 49 70
Fax: +46 (0) 31 99 48 70
E-mail: info@scanmaskin.se
Website: www.scanmaskin.se

Denmark

Torvegade 22
DK-7330 Brande

Phone: +45 97 18 00 58
Fax: +45 97 18 45 58
E-mail: info@scanmineral.dk
Website: www.scanmaskin.se

Norway

Postboks 6, Furuset
N-1001 Oslo
Tomtveien 12
N-2015 Leisund

Phone: +47 63 87 60 00
Fax: +47 63 87 60 01
E-mail: info@scanmaskin.no
Website: www.scanmaskin.no

Finland

Raudoittajantie 3 A
FIN-06450 Porvoo / Borgå

Phone: +358 10 292 4700
E-mail: info@scanmaskin.fi
Website: www.scanmaskin.fi

USA

1407 132nd Avenue Northeast, Suite 8
Bellevue, Washington, 98005

Phone: +1 425 209 0147
E-mail: info@scanmaskin.com
Website: www.scanmaskin.com



SCANMASKIN

MACHINES—MINERALS—KNOW-HOW

SCANMASKIN SWEDEN AB

Huvudkontor / Head office
Box 187

SE-437 22 Lindome

Phone: +46 (0)31- 99 49 70

Fax: +46 (0)31- 99 48 70

Email: info@scanmaskin.com

Besöksadress / Visiting address

Heljesvägen 10

SE-437 36 Lindome

www.scanmaskin.com