

HILTI

PD 40

Operating instructions	en
Brugsanvisning	da
Bruksanvisning	sv
Bruksanvisning	no
Käyttöohje	fi
Инструкция по эксплуатации	ru
Lietošanas pamācība	lv
Instrukcija	lt
Kasutusjuhend	et

CE

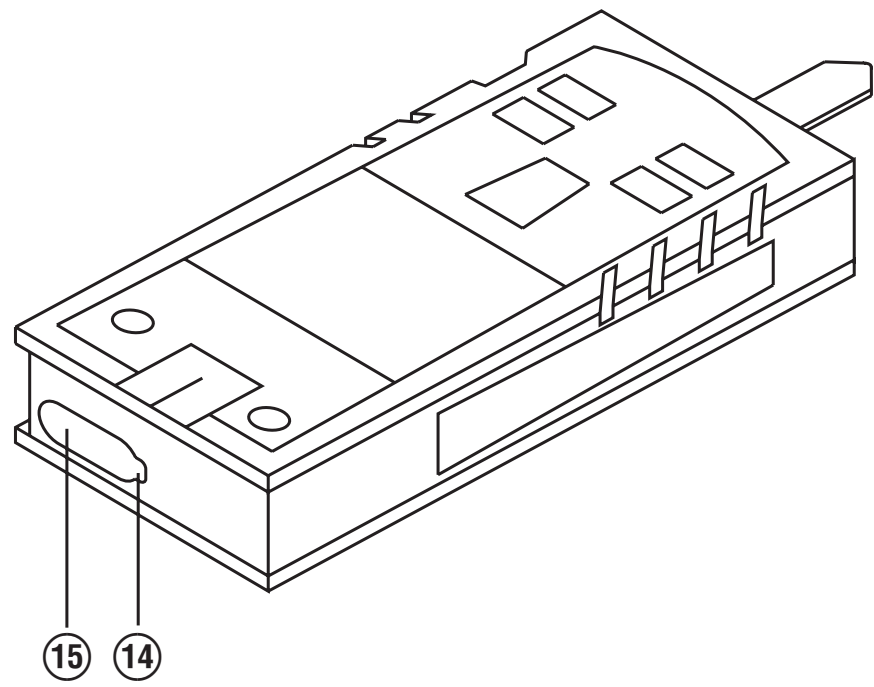
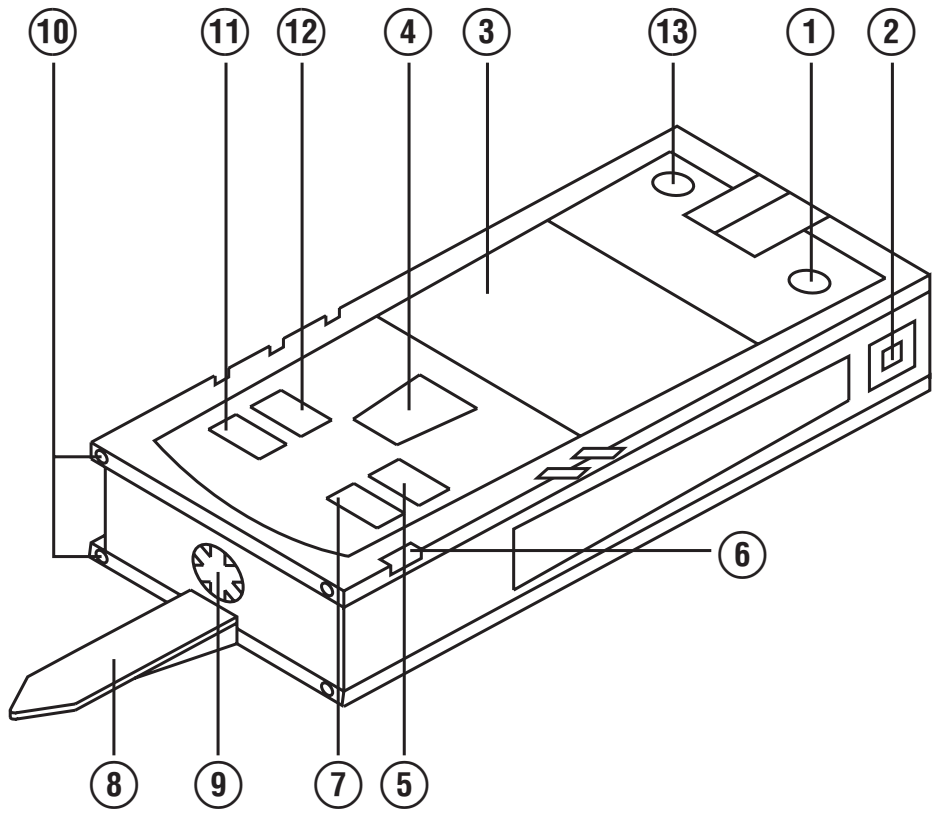

2

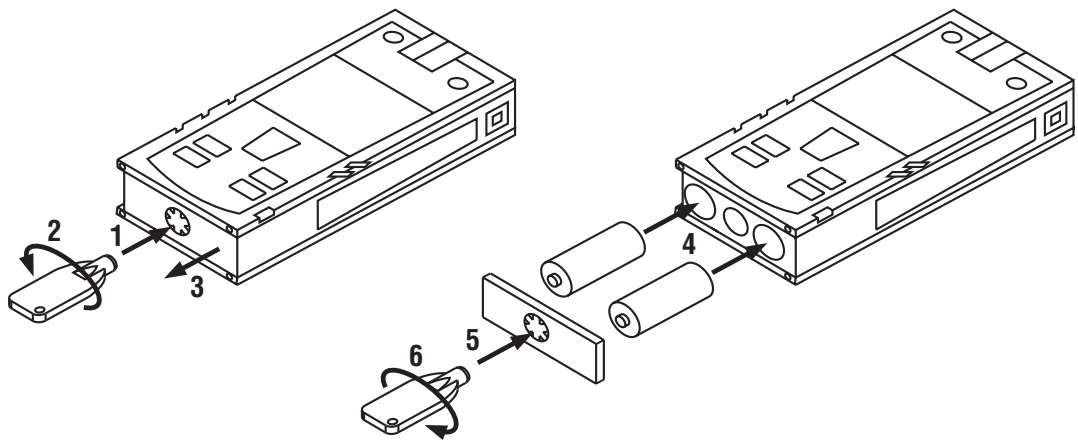

3

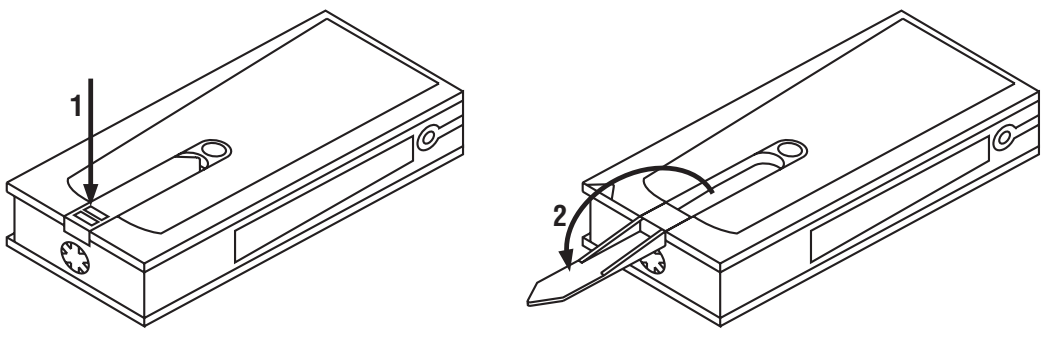

4

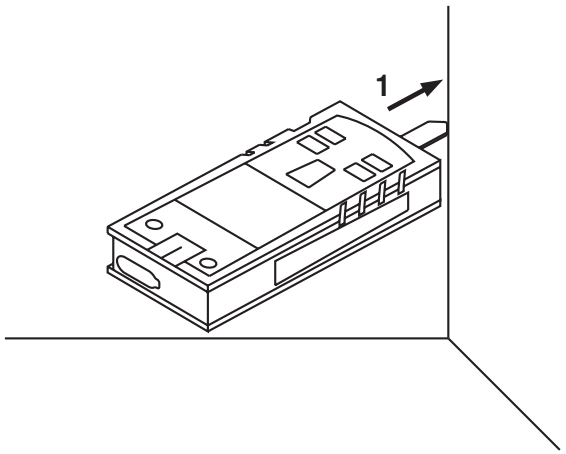

5

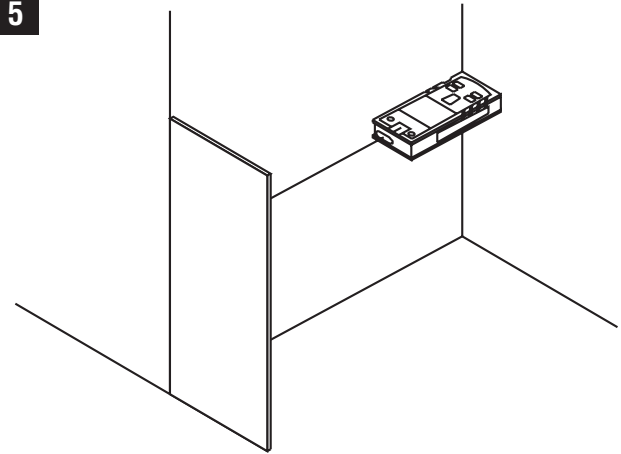

6

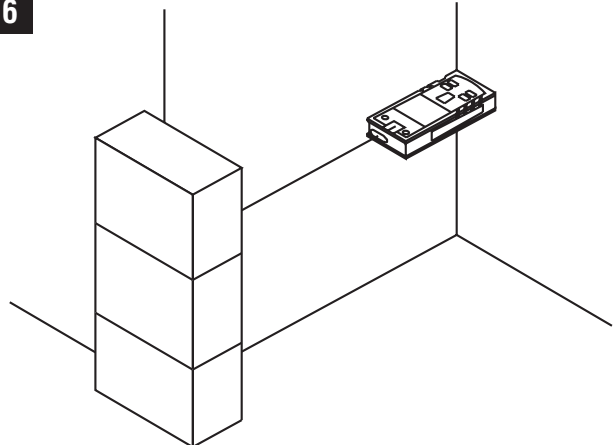

7

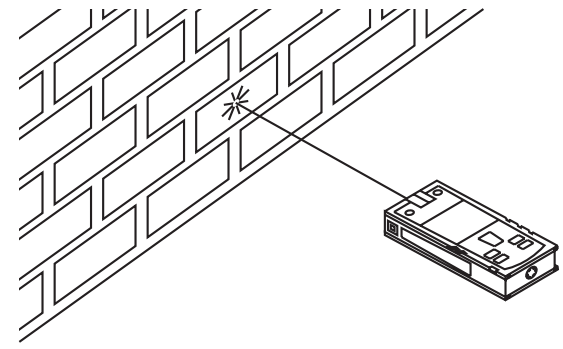

PD 40 laser range meter

It is essential that the operating instructions are read before the tool is operated for the first time.

Always keep these operating instructions together with the tool.

Ensure that the operating instructions are with the tool when it is given to other persons.

Contents	Page
1. General information	17
2. Description	18
3. Insert tools, accessories	22
4. Technical data	22
5. Safety rules	23
6. Before use	24
7. Operation	28
8. Care and maintenance	30
9. Troubleshooting	31
10. Disposal	32
11. Manufacturer's warranty - tools	32
12. EC declaration of conformity	33

1 These numbers refer to the corresponding illustrations. The illustrations can be found on the fold-out cover pages. Keep these pages open while studying the operating instructions.

In these operating instructions, the designation "the tool" always refers to the PD 40 laser range meter.

en

Parts, operating controls and indicators **1**

- ① On/off button
- ② Side measure button
- ③ Graphic display
- ④ Measure button
- ⑤ Delete (clear) button
- ⑥ Horizontal bubble
- ⑦ Area button
- ⑧ Folding spike
- ⑨ 1/4" thread for PDA 71 measuring extension
- ⑩ Rear contact points
- ⑪ Minus button
- ⑫ Plus button
- ⑬ Reference button
- ⑭ Laser exit lens
- ⑮ Receiving lens

1. General information

1.1 Safety notices and their meaning

DANGER

Draws attention to imminent danger that could lead to serious bodily injury or fatality.

WARNING

Draws attention to a potentially dangerous situation that could lead to serious personal injury or fatality.

CAUTION

Draws attention to a potentially dangerous situation that could lead to slight personal injury or damage to the equipment or other property.

NOTE

Draws attention to an instruction or other useful information.

1.2 Explanation of the pictograms and other information

Warning signs



General warning

en

Symbols



Read the operating instructions before use.



Return waste material for recycling.



Laser class II according to CFR 21, § 1040 (FDA)



Laser class 2 in accordance with EN 60825-1:2003



Do not look into the beam.



Temperature indicator



Battery status indicator



Hardware errors



Unfavorable operating conditions

Type identification plate

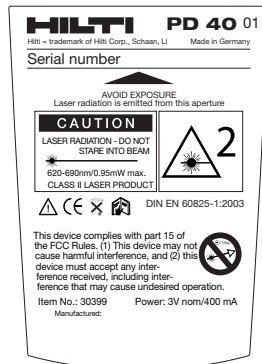

PD 40

Location of identification data on the tool

The type designation and serial number can be found on the type identification plate on the tool. Make a note of this data in your operating instructions and always refer to it when making an enquiry to your Hilti representative or service department.

Type: _____

Serial no.: _____

2. Description

2.1 Use of the product as directed

The tool is designed for measuring distances, calculating areas and adding or subtracting distances.

Do not use the tool as a leveling tool.

Measurements taken from plastic foam materials such as polystyrene foam, from snow or from highly reflective surfaces (mirrors, glass, etc.) may produce inaccurate results.

The tool and its ancillary equipment may present hazards when used incorrectly by untrained personnel or when used not as directed.

Take the influences of the surrounding area into account. Do not use the appliance where there is a risk of fire or explosion.

Observe the information printed in the operating instructions concerning operation, care and maintenance.

To avoid the risk of injury, use only genuine Hilti accessories and additional equipment.

Modification of the tool is not permissible.

NOTE

Observe the permissible operating and storage temperatures.

en

2.2 Display

The measurements, settings and tool status are shown in the display. When the tool is in measuring mode, the measurements taken are shown at the bottom of the display area (the result line). When using a function, e.g. area measurement, the distances measured are shown in the intermediate result line and the calculated result is shown at the bottom of the display (the result line).

2.3 Display illumination

In low light conditions, the display is illuminated automatically as soon as a button is pressed. The display illumination intensity is reduced to 50% after 10 seconds. If no button is pressed over a period of 20 seconds, the display illumination switches off automatically.

NOTE

Illumination of the display consumes battery power. Shorter battery life is therefore to be expected when this feature is used frequently.

2.4 Basic principle

The distance is measured along a laser beam emitted by the tool to the point at which the beam strikes a reflective surface. The target from which the measurement is taken is clearly identified by the red laser measuring spot. The range of the tool depends on the reflectance and structure of the target surface from which measurements are taken.

2.5 Measuring principle

The tool emits a visible laser beam carrying signal pulses which are reflected by the target. The time between reflected pulses is used as a basis for determining the distance.

This measuring principle permits highly accurate and reliable measurement of distances to objects without need for special reflectors.

2.6 Standard measuring display mode

Standard measuring display mode is always activated when the "On/off" or "Measure" button is pressed to switch the tool on.

2.7 Symbols in the display

Temperature	Temperature too high (>+50°C) / too low (<-10°C).	Allow the tool to cool down or warm up.
Unfavorable operating conditions	Insufficient reflected laser light.	Observe the minimum measuring distance (50 mm from the front edge of the tool); clean the lenses; take measurements from a different surface or use a target plate.
General hardware error		Switch the tool off and on again. If the fault persists, please contact Hilti Service.

2.8 Control panel

Measure button		Activates the laser beam.
		Begins distance measurement.
		Activates continuous measuring mode (long press, approx. 2 sec.).
		Stops continuous measuring mode.
Plus button		Activates distance and area addition.
		Distances shown in the standard measuring display are added.
Minus button		Adds areas when in area measuring mode.
		Activates distance and area subtraction.
		Distances shown in the standard measuring display are subtracted.
Area button		Subtracts areas when in area measuring mode.
		Activates area measuring mode.
		When measurements have been taken: Deletes all measurements and restarts the function.
		When no measurements have been taken: ends area measuring mode.
Delete (clear) button	The C-button has various functions depending on operating mode.	Stops continuous measuring (tracking).
		Stops continuous measuring (tracking).
		Clears the standard measuring display.
		Clears the last measurement and returns to "Functions".
On/off button		Ends area measuring mode if no measurements have been taken.
		When the tool is switched off, press the button briefly to switch it on.
		When the tool is switched off, press and hold the button to activate the menu.
Reference button		When the tool is switched on, press the button briefly to switch it off.
		Switches the various measuring references between front and rear.

2.9 Battery condition indicator

Number of segments shown	Charge status in %
4	= 100 % capacity
3	= 75 % capacity
2	= 50 % capacity
1	= 25 % capacity
0	Fully discharged

en

2.10 Items supplied as standard

- 1 PD 40 laser range meter
- 1 Hand strap
- 2 Batteries
- 1 Battery compartment key
- 1 Operating instructions
- 1 Manufacturer's certificate

2.11 PUA 60 laser visibility glasses

The laser visibility glasses have no protective function and thus do not protect the eyes from laser beams. As these glasses limit color vision they must not be worn by persons driving on a public road and must not be used to look directly into the sun.

The PUA 60 laser visibility glasses improve laser beam visibility considerably.

2.12 PDA 50 / 51 / 52 target plate

The PDA 50 target plate is made of durable plastic with a special reflective coating. Use of the target plate is recommended at distances greater than 10 m in poor light conditions.

The PDA 51 target plate has no reflective coating and its use is recommended in poor light conditions and at short distances. The PDA 52 target plate is equipped with the same reflective coating as the PDA 50 but is considerably larger in size (A4 format, 210 x 297 mm). This makes it much easier to aim the tool at the target plate over long distances.

NOTE

For reliable distance measurements, care should be taken to ensure that the laser beam strikes the target plate at right angles as far as possible. The laser spot on the target plate and the measuring reference point (starting point) may otherwise be in different planes (parallax error).

NOTE

When the target plate is used and very high accuracy is required, 1.2 mm should be added to the measurement obtained.

2.13 PDA 71 measuring extension

The measuring extension is made from aluminium and is equipped with a non-conductive synthetic rubber grip. The screw on the measuring extension should be screwed into the threaded bush on the rear contact surface of the PD 40. When the measuring extension is screwed onto the tool, the rear reference is then relocated to the tip of the measuring extension, i.e. the rear reference is extended by 1270 mm (50 inches).

3. Insert tools, accessories

Target plate	PDA 50
Target plate	PDA 51
Target plate	PDA 52
Measuring extension	PDA 71
Hand strap	PDA 60
Soft pouch	PDA 65
Laser visibility glasses	PUA 60

en

4. Technical data

Right of technical changes reserved.

Technical data	Values
Power supply	3V DC AA-size batteries
Battery condition check	Battery condition indicator with 4 segments showing 100%, 75%, 50%, 25% charge : No segments shown: The batteries are exhausted
Measuring range	0.05...200 m
Typical measuring range without target plate	Drywall panel, white: 100 m Concrete, dry: 70 m Brick, dry: 50 m
Accuracy	Typically ± 1.0 mm for single and continuous measurement
Smallest unit displayed	1 mm
Beam diameter	Beam length 10 m: Max. 6 mm Beam length 50 m: Max. 30 mm Beam length 100 m: Max. 60 mm
Basic operating modes	Single measuring, continuous measuring, calculation/functions
Display	Illuminated dot-matrix display with permanent indication of operating mode and battery condition
Laser	Visible 635 nm, Output power less than 1 mW: Laser class 2 IEC 825- 1:2003CFR 21 § 1040 (FDA)
Automatic cut-out	Laser: 1 min Tool: 10 min
Battery life	Max. number of measurements with laser beam switched on for a time of 10 s Alkaline 8,000...10,000 NiMH 6,000...8,000
Operating temperature range	-10...+50°C
Storage temperature	-30...+70°C
Protection class (except battery compartment)	IP 54 protection against dust and water jets IEC 529

Technical data	Values
Weight without batteries	170 g
Dimensions	120 mm x 55 mm x 28 mm

Menu / units	Distance	Area	Volume
m	Meters	m ²	m ³
cm	Centimeters	m ²	m ³
mm	Millimeters	m ²	m ³
In	Inches, decimal	Inches ²	Inches ³
In 1/8	1/8 inch	Inches ²	Inches ³
In 1/16	1/16 inch	Inches ²	Inches ³
In 1/32	1/32 inch	Inches ²	Inches ³
Ft	Feet, decimal	Feet ²	Feet ³
Ft 1/8	Feet-inches-1/8	Feet ²	Feet ³
Ft 1/16	Feet-inches-1/16	Feet ²	Feet ³
Ft 1/32	Feet-inches-1/32	Feet ²	Feet ³
Yd	Yards, decimal	Yards ²	Yards ³

en

5. Safety rules

In addition to the information relevant to safety given in each of the sections of these operating instructions, the following points must be strictly observed at all times.

5.1 Basic information concerning safety

- Do not render safety devices ineffective and do not remove information and warning notices.
- Keep laser tools out of reach of children.
- Failure to follow the correct procedures when opening the tool may cause emission of laser radiation in excess of class 2. **Have the tool repaired only at a Hilti service center.**
- Check that the tool functions correctly each time before use.
- Operation of the tool in the proximity of pregnant women is not permissible.
- Measurements taken from surfaces with low reflectivity in highly reflective surroundings may be inaccurate.
- Measurements taken through panes of glass or other objects may be inaccurate.
- Rapid changes in the conditions under which the measurement is taken, e.g. persons walking through the laser beam, may lead to inaccurate results.

- Do not point the tool toward the sun or other powerful light sources.

5.2 Proper organization of the workplace

- Avoid unfavorable body positions when working on ladders or scaffolding. Make sure you work from a safe stance and stay in balance at all times.
- Check the measuring reference setting before taking the measurement.
- When the tool is brought into a warm environment from very cold conditions, or vice-versa, allow it to become acclimatized before use.
- As a precaution, check the previous settings and adjustments you have made.
- When setting up the tool with the aid of the bubble level, view the bubble level at a slight angle.
- Secure the area in which you are working and take care to avoid directing the beam towards other persons or towards yourself when setting up the tool.
- Use the tool only within its specified limits.
- Observe the accident prevention regulations applicable in your country.

5.3 Electromagnetic compatibility

Although the tool complies with the strict requirements of the applicable directives, Hilti cannot entirely rule out the possibility of the tool being subject to interference caused by powerful electromagnetic radiation, leading to incorrect operation. Check the accuracy of the tool by taking measurements by other means when working under such conditions or if you are unsure. Likewise, Hilti cannot rule out the possibility of interference with other devices (e.g. aircraft navigation equipment). The tool complies with the requirements of class A; The possibility of interference occurring in a domestic environment cannot be excluded.

5.4 General safety rules

- Check the condition of the tool before use. If the tool is found to be damaged, have it repaired at a Hilti service center.**
- The user must check the accuracy of the tool after it has been dropped or subjected to other mechanical stresses.**
- Although the tool is designed for the tough conditions of jobsite use, as with other measuring instruments it should be treated with care.**
- Although the tool is protected to prevent entry of dampness, it should be wiped dry each time before being put away in its transport container.**

5.5 Electrical

- Keep the batteries out of reach of children.**
- Do not allow the batteries to overheat and do not expose them to fire.** The batteries may explode or release toxic substances.
- Do not charge the batteries.**
- Do not solder the batteries into the tool.**
- Do not discharge the batteries by short-circuiting.** This may cause them to overheat and present a risk of personal injury (burns).
- Do not attempt to open the batteries and do not subject them to excessive mechanical stress.**

5.6 Laser classification

Depending on the version purchased, the tool complies with Laser Class 2 in accordance with IEC825-1:2003 / EN60825-1:2003 and Class II in accordance with CFR 21 § 1040 (FDA). This tool may be used without need for further protective measures. The eyelid closure reflex protects the eyes when a person looks into the beam unintentionally for a brief moment. This eyelid closure reflex, however, may be negatively affected by medicines, alcohol or drugs. Nevertheless, as with the sun, one should not look directly into sources of bright light. Do not direct the laser beam toward persons.

5.7 Transport

Always remove the batteries before shipping the tool.

6. Before use



6.1 Inserting the batteries 2

CAUTION

Do not use damaged batteries.

CAUTION

Always replace the complete set of batteries.

DANGER

Do not mix old and new batteries. Do not mix batteries of different makes or types.

- Unscrew the battery compartment cover from the rear of the tool.
- Remove the batteries from the packaging and insert them in the tool.
NOTE Take care to observe correct polarity (see symbols in battery compartment).
- Check to ensure that the battery compartment cover is closed securely.

6.2 Switching the tool on / off

- The tool can be switched on by pressing either the "On / off" button or the "Measure" button.

- When the tool is switched off, press the "On / off" button: The tool switches on.
The laser beam is switched off.
- When the tool is switched on, press the "On / off" button: The tool switches off.
- When the tool is switched off, press the "Measure" button: The tool and the laser beam switch on.

6.3 First distance measurements

- Press the "Measure" button once.
If switched off, the tool will be switched on and the laser beam activated.
If the tool is already switched on, the laser beam will be activated.
- Aim the tool by positioning the visible laser spot on a white surface at a distance of approx. 3 - 10 m.
- Press the "Measure" button again.
The distance will be displayed in less than a second, e.g. 5.489 m.
You have just taken your first measurement with the tool.

6.4 Settings menu

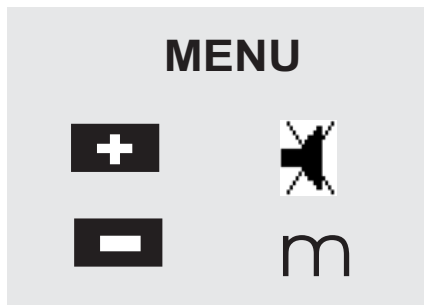

- With the tool switched off, press the "On / off" button for approx. 2 seconds to enter menu mode.
- Press the "Plus" button to switch the beep signal on or off.
- Press the "Minus" button repeatedly to scroll through the choice of units.
- Press the "On / off" button briefly to close the menu.
The tool is switched off and all the settings shown will be saved.

6.5 Measuring references

NOTE

The tool can take measurements from 4 different reference (contact) points. The "Reference" button on the left on the front of the tool is used to switch between the front and rear references (front or rear edge of the tool). The reference is set automatically to the tip of the spike when the spike is folded out through 180°. When the measuring extension is screwed into place, this is detected automatically by the tool and indicated by the long extension symbol in the display.

en

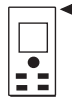

Front edge



Rear edge



Spike



PDA 71 measuring extension: is detected automatically when screwed in.

6.6 Measuring distances

NOTE

When the spike is folded back in, the measuring reference is always reset to the rear edge of the tool irrespective of how far the spike was folded out or to which point on the tool the measuring reference was previously set.

Distances can be measured from all stationary targets without a highly reflective surface, i.e. concrete, stone, wood, plastic, paper, etc. The use of prisms or other highly reflective targets is not permissible and, if attempted, may falsify the results.

6.6.1 Measuring distances step by step

en NOTE

The range meter measures distances in a very short time and simultaneously shows various information in the display.

Switch the tool on by pressing the "On / off" button.

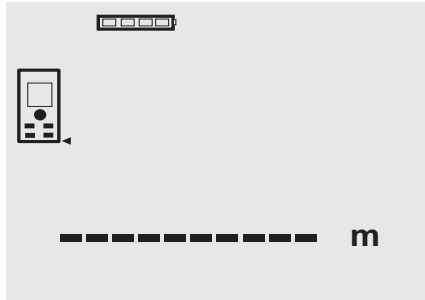

Press the "Measure" button once. The laser beam is switched on and is visible in the form of a spot on the target surface. This aiming mode is indicated in the display by a blinking laser symbol.



Aim at the target. Press the "Measure" button once again to measure the distance. The result usually appears in the result line in less than a second and the laser beam then switches off.

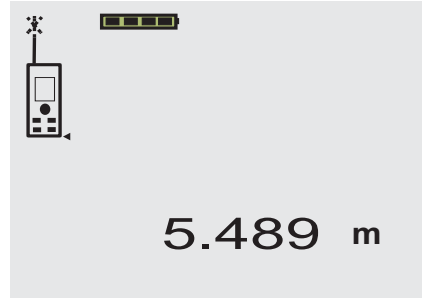

If further measurements are taken, up to three previously determined distances are shown in the intermediate result lines, i.e. a total of the last four measured distances are shown.

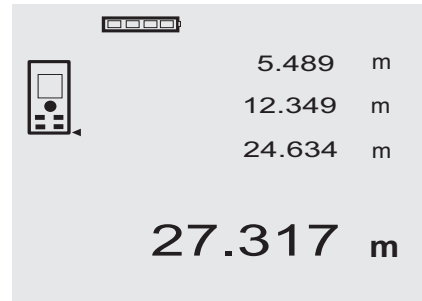

The tool can, of course, be switched on again at any time by pressing the "Measure" button. Pressing the C-button clears all currently displayed values.

6.6.2 Measuring modes

Distances can be measured using two different measuring modes, i.e. single distance measuring or continuous measuring. Continuous measuring mode is used for setting out given distances or lengths and can also be used where distance measurement is otherwise difficult, e.g. at corners, edges or in niches, etc.

6.6.2.1 Single distance measuring ("Measure" button)

1. Switch the laser beam on by pressing the "Measure" button.
2. Press the "Measure" button again.
The measured distance will be shown in the result line at the bottom of the display in less than a second.

6.6.2.2 Single distance measuring ("On /off" button)

1. Switch the laser beam on by pressing the "On / off" button.
2. Press the "Measure" button to switch the laser beam on and then aim the tool at the target.
3. Press the "Measure" button again.
The measured distance will be shown in the result line at the bottom of the display in less than a second.

6.6.2.3 Continuous measuring (tracking)

NOTE

Continuous measuring is possible in all situations where individual distances can be measured. This applies also to functions, such as areas.

1. Press the "Measure" button for about 2 seconds to activate the continuous measuring mode.
NOTE When doing so, it doesn't matter whether the tool or the laser beam is switched on or off. The tool will always switch to continuous measuring mode.
During continuous measuring, distances are updated in the result line at the rate of approx. 6 - 10 measurements every second. The measuring rate depends on reflectivity of the target surface. If the beep signal is active, continuous measuring is indicated by a beep signal approx. 2 - 3 times per second.
2. Measuring is stopped by pressing the "Measure" button once again.
The last valid measurement is then shown in the result line in the display.

6.6.3 Measuring from corners 3 4

The spike is used when measuring diagonally across rooms or from inaccessible corners.

1. Fold out the spike through 180°. The measuring reference is then set automatically to the end of the spike. The range meter takes the extended reference point into account and corrects the measured distances accordingly.
2. Position the range meter with the spike at the desired starting point for the measurement and aim toward the target.
3. Press the "Measure" button.
The measured distance is shown in the display.

6.6.4 Measuring with the aid of target objects 5 6

When taking measurements to outside corners (e.g. on outside walls of buildings, perimeter fences, etc.), boards, bricks or other suitable objects can be held against the corner and used as the target. Use of the PDA 50, PDA 51 or PDA 52 target plate is recommended for long distances and in unfavorable light conditions, e.g. in strong sunlight.

6.6.5 Measuring in bright conditions

We recommend use of the PDA 50, PDA 51 or PDA 52 target plate for long distances and in very bright light conditions.

6.6.6 Taking measurements to rough surfaces 7

When measuring to rough surfaces, e.g. rough plaster etc., an average distance value is measured with the center of the laser spot weighted higher than the edges of the laser spot.

6.6.7 Taking measurements to curved or inclined surfaces

If the laser beam strikes the target surface at a very narrow angle, the light reflected may be inadequate. Conversely, too much light may be reflected toward the tool in situations where the laser beam strikes the target perpendicularly. We recommend use of the PDA 50, PDA 51 or PDA 52 target plate in both of these situations.

6.6.8 Taking measurements to wet or shiny surfaces

As long as the range meter can be aimed directly at the surface, the distance to the target will be reliably measured. With highly reflective surfaces, a reduction

en

in range must be expected and the distance to the actual point of reflection may be measured.

6.6.9 Taking measurements to transparent surfaces

en

It is generally possible to measure distances to transparent or semi-transparent materials, e.g. liquids, polystyrene foam, etc. Light penetrates these materials, however, and measuring errors may therefore occur. Measuring errors may also occur when measurements are taken through glass or if objects are present within the line of the laser beam.

6.6.10 Measuring range

6.6.10.1 Increased range

The range of the tool is generally increased when measurements are taken in the dark, at dawn or dusk

and when the target and/or the tool is shaded from bright light.

Use of the PDA 50, PDA 51 or PDA 52 target plate also increases the range of the tool.

6.6.10.2 Reduced measuring range

Measuring range may be reduced in bright conditions, e.g. in bright sunlight or when working under very powerful floodlights.

The range of the tool may be reduced when measurements are taken through glass or when objects lie within the path of the laser beam.

The range of the tool may be reduced when measurements are taken to mat green, blue or black surfaces or to wet or shiny surfaces.

7. Operation



7.1 Distance measurements

NOTE

With all functions of the tool, each step in the operation is always indicated in the display.

NOTE

Continuous measuring mode can be used with all functions in which individual distance measurement is possible.

NOTE

If measuring errors occur during continuous measuring, and continuous measuring mode is canceled by pressing the "Measure" button again, the last valid measurement will be displayed.

7.2 Adding distances

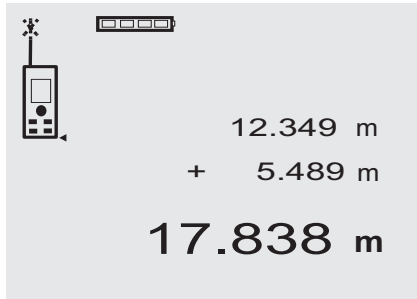

Individual distances can be conveniently added. This is useful, for example, for determining the total length of the inner face of door or window openings or

for adding several individual distances that form a perimeter.

1. Press the "Measure" button (the laser beam will switch on).
2. Aim the range meter at the target.
3. Press the "Measure" button.
The first distance will be measured and displayed (the laser then switches off).
4. Press the "Plus" button. The first distance is then displayed in the middle result line and a plus sign appears in the lower (intermediate) result line (the laser beam switches on).
5. Aim the range meter at the target.
6. Press the "Measure" button.
The second distance is then measured and displayed in the lower (intermediate) result line. The result of the addition is shown in the result line.
The current total of the distances is always shown in the result line.
The procedure can be repeated until all distances have been added.
7. To terminate the addition of distances, simply measure a distance without first pressing the "Plus" button.
All previous measuring and calculation results are shown in the intermediate results lines.
8. Press the C-button to clear the display.

7.3 Subtracting distances



Individual distances can be conveniently subtracted from each other, e.g. in order to determine the distance between the underside of a pipe and the ceiling. This can be done by subtracting the distance between the floor and the underside of the pipe from the distance between the floor and the ceiling. If the pipe diameter is subtracted, the result is the distance between the top of the pipe and the ceiling.

1. Press the "Measure" button (the laser beam switches on).
2. Aim the range meter at the target.
3. Press the "Measure" button. The first distance will be measured and displayed (the laser then switches off).
4. Press the "Minus" button. The first distance is then displayed in the middle result line and a minus sign appears in the lower (intermediate) result line (the laser beam switches off).
5. Aim the range meter at the target.
6. Press the "Measure" button.
The second distance is then measured and displayed in the lower (intermediate) result line. The result of the subtraction is shown in the result line.
The current difference in distance is always shown in the result line.
The procedure can be repeated until all distances have been subtracted.
7. To terminate the subtraction of distances, simply measure a distance without first pressing the "Minus" button.
All previous measuring and calculation results are shown in the intermediate results lines.
8. Press the C-button to clear the display.

en

7.4 Measuring areas

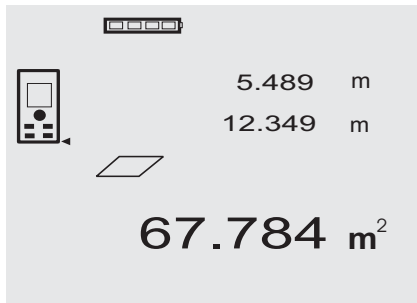

Each step of the area measurement operation is indicated graphically in the display. For example, to determine the floor area of a room, proceed as follows:

1. Press the "Area" button to activate area measuring mode.
NOTE When the area function is activated, the laser beam is already switched on.

en

2. Aim the range meter at the target.
3. Press the "Measure" button.
For example, to determine the floor area of a room, proceed as follows:
The graphic display automatically prompts you to measure the length of the room.
4. Aim the tool at the next target to obtain the length of the room.
5. Press the "Measure" button.
The second distance is then measured, the area calculated immediately and the result is displayed in the result line.
Both distances used for the area calculation are shown in the intermediate result lines and can be noted down conveniently at the end of the operation.
6. The C-button can be pressed at any time to stop the measuring operation. Each measurement can then be cleared, one after the other, and measuring restarted.
NOTE If the C-button is pressed several times or the FNC-button is pressed, the function will be canceled or, respectively, restarted.
NOTE If the second distance is measured using continuous measuring mode (tracking), the result of the area calculation is updated continuously. This allows parts of the area to be included/excluded.
NOTE After calculation of an area, the "Plus" button can be pressed to add another area or, respectively, the "Minus" button used to subtract an area.

8. Care and maintenance

8.1 Cleaning and drying

1. Blow dust off the lenses.
2. Do not touch the glass or the filter with the fingers.
3. Use only a clean, soft cloth for cleaning. If necessary, moisten the cloth slightly with pure alcohol or a little water.
NOTE Do not use any other liquids as these may damage the plastic components.
4. The temperature limits for storage of your equipment must be observed, especially in winter / summer.

8.2 Storage

Remove the tool from its case if it has become wet. The tool, its carrying case and accessories should be cleaned and dried (at maximum 40°C / 104°F). Repack the equipment only once it is completely dry. Check the accuracy of the equipment before it is used after a long period of storage or transportation. Remove the batteries from the tool before storing it for a long period. Leaking batteries may damage the tool.

8.3 Transport

Use the Hilti toolbox or packaging of equivalent quality for transporting or shipping your equipment.

CAUTION

Always remove the batteries before shipping the tool.

8.4 Calibration and adjustment

8.4.1 Calibration

Monitoring of measuring equipment for users certified in accordance with ISO 9000X: As specified in ISO 900X, you may carry out the inspection and testing of the PD 40 laser range meter yourself (see ISO 17123-4: Field Process for Accuracy Examination of Geodetic Instruments: Part 6, Close-range Opto-electrical Range Meters).

1. Select a readily accessible measuring distance of a known length (approx. 1 to 5 meters / 3 to 15 feet) which does not change over time and measure the same distance 10 times.
2. Determine the mean deviation from the known distance. This value should be within the specified accuracy tolerance for the tool.
3. Keep a record of this value and note the date when the next test is due.
Repeat this test at regular intervals as well as before and after important measuring tasks.
Apply a test and inspection confirmation sticker to the PD 40 and keep a record of the entire monitoring, test and inspection procedure and the results.
Please refer to the technical data contained in the operating instructions and the information concerning measuring accuracy.

8.4.2 Adjustment

To ensure that the laser range meter is adjusted correctly, we recommend that it is returned to a Hilti Service Center for calibration. Accurate adjustment of the tool will be confirmed by a calibration certificate.

8.4.3 Hilti calibration service

We recommend that the tool is checked by the Hilti calibration service at regular intervals in order to verify its reliability in accordance with standards and legal requirements.

Use can be made of the Hilti calibration service at any time, but checking at least once a year is recommended.

The calibration service provides confirmation that the tool is in conformance, on the day it is tested, with the specifications given in the operating instructions. The tool will be readjusted if deviations from the manufacturer's specification are found. After checking and adjustment, a calibration sticker applied to the tool and a calibration certificate provide written verification that the tool operates in accordance with the manufacturer's specification.

Calibration certificates are always required by companies certified according to ISO 900x.

Your local Hilti Center or representative will be pleased to provide further information.

en

9. Troubleshooting

Fault	Possible cause	Remedy
The tool can't be switched on.	The batteries are exhausted.	Replace the batteries.
	Incorrect battery polarity.	Insert the batteries correctly and close the battery compartment cover.
	The button is faulty.	Return the tool to Hilti for repair.
No distances displayed by the tool.	"Measure" button was not pressed.	Press the "Measure" button.
	Faulty display.	Return the tool to Hilti for repair.
Frequent error messages or the tool doesn't measure.	The target surface is too brightly lit by the sun.	Measure from the other direction – sun from behind.
	The target surface is too shiny.	Take measurements from less shiny surfaces.
	The target surface is too dark.	Use the PDA 50/ PDA 51/ PDA 52 target plate.
	Bright sunlight towards the tool.	Use the PDA 50/ PDA 51/ PDA 52 target plate.
Measuring reference not set to the spike.	The spike is not folded out fully.	Fold the spike out fully.
	The spike is faulty.	Return the tool to Hilti for repair.
Measuring reference not set to the extension.	The measuring extension is not screwed in fully.	Screw the measuring extension in fully.
	Dirt or foreign matter in the threaded bush.	Clean the threaded bush.
No result obtained using functions.	Distance measurements are missing.	Measure the missing distance(s).
	Numerical value of the result is too high (cannot be displayed).	Change to a larger unit.

10. Disposal

WARNING

Improper disposal of the equipment may have serious consequences:

The burning of plastic components generates toxic fumes which may present a health hazard.

Batteries may explode if damaged or exposed to very high temperatures, causing poisoning, burns, acid burns or environmental pollution.

en

Careless disposal may permit unauthorized and improper use of the equipment. This may result in serious personal injury, injury to third parties and pollution of the environment.



Most of the materials from which Hilti tools or appliances are manufactured can be recycled. The materials must be correctly separated before they can be recycled. In many countries, Hilti has already made arrangements for taking back old tools and appliances for recycling. Ask Hilti customer service or your Hilti representative for further information.



For EC countries only

Disposal of electric tools together with household waste is not permissible.

In observance of European Directive 2002/96/EC on waste electrical and electronic equipment and its implementation in accordance with national law, electric tools that have reached the end of their life must be collected separately and returned to an environmentally compatible recycling facility.



Dispose of the batteries in accordance with national regulations.

11. Manufacturer's warranty - tools

Hilti warrants that the tool supplied is free of defects in material and workmanship. This warranty is valid so long as the tool is operated and handled correctly, cleaned and serviced properly and in accordance with the Hilti Operating Instructions, and the technical system is maintained. This means that only original Hilti consumables, components and spare parts may be used in the tool.

This warranty provides the free-of-charge repair or replacement of defective parts only over the entire lifespan of the tool. Parts requiring repair or replacement as a result of normal wear and tear are not covered by this warranty.

Additional claims are excluded, unless stringent national rules prohibit such exclusion. In particular, Hilti is not obligated for direct, indirect, incidental or consequential damages, losses or expenses in connection with, or by reason of, the use of, or inability to use the tool for any purpose. Implied warranties of merchantability or fitness for a particular purpose are specifically excluded.

For repair or replacement, send the tool or related parts immediately upon discovery of the defect to the address of the local Hilti marketing organization provided.

This constitutes Hilti's entire obligation with regard to warranty and supersedes all prior or contemporaneous comments and oral or written agreements concerning warranties.

12. EC declaration of conformity

Designation:	Laser range meter
Type:	PD 40
Year of design:	2006

We declare, on our sole responsibility, that this product complies with the following directives and standards: EN 50081-1, EN 61000-6-2, 89/336/EEC.

Hilti Corporation



Bodo Baur
Quality Manager
BA Electric Tools & Accessories
01 2007



Tassilo Deinzer
Head BU Measuring Systems
BU Measuring Systems
01 2007

en

HILTI

Hilti Corporation

LI-9494 Schaan

Tel.: +423 / 234 21 11

Fax: +423 / 234 29 65

www.hilti.com



320291