

Meet

DINO 180XTB II

DINO® TRAILER MOUNTED MEWPs

Standard features in DINO 180XTB II:

- Spider outriggers; great levelling capability in slopy terrain
- Large outreach 11.2 m / 120 kg, 9.1 m / 215 kg
- Driving system; easy to move at work site
- Cable steering for driving
- Hydraulic basket rotation 180°
- Spacious, easy-entry basket; capacity 215 kg
- Large outrigger pads 280 x 360 mm
- Continuous rotation of the boom; easy and functional
- Stable to tow
- Easy and fast setup; perfect solution for short time jobs
- Simple to use, clear and informative controls
- Powerful charger; machine can be operated directly when charging the batteries
- High-capacity batteries, 4 x 6VDC, 235Ah
Work one day with overnight charge



Options available for DINO 180XTB II:

- Automatic levelling
- Two joystick controls
- Outrigger support indicator
- LED working lights
- Extra outrigger pads 500 x 500 x 35 mm + bracket
- Lockable tool / harness box
- Rack for tools and accessories
- Spare wheel
- DINO SafeGuard secondary guarding
- 2kW Honda generator + bracket for charging batteries where 230VAC is not available

Technical data

	180XTB II
Max. working height	18.00 m
Max. platform height	16.00 m
Max. outreach	11.20 m
Support width	3.9 / 4.3 m
Lifting capacity	215 kg
Basket size	0.7 x 1.3 m
Boom rotation	cont.
Basket rotation	180°
Boom control	proport.
Transport length	6.66 m
Transport width	1.95 m
Transport height	2.30 m
Weight	2380 kg
Driving system	std
AC socket in the basket x 2	std
Batteries 235 Ah	std
DC Motor	std
Gradeability	25 %

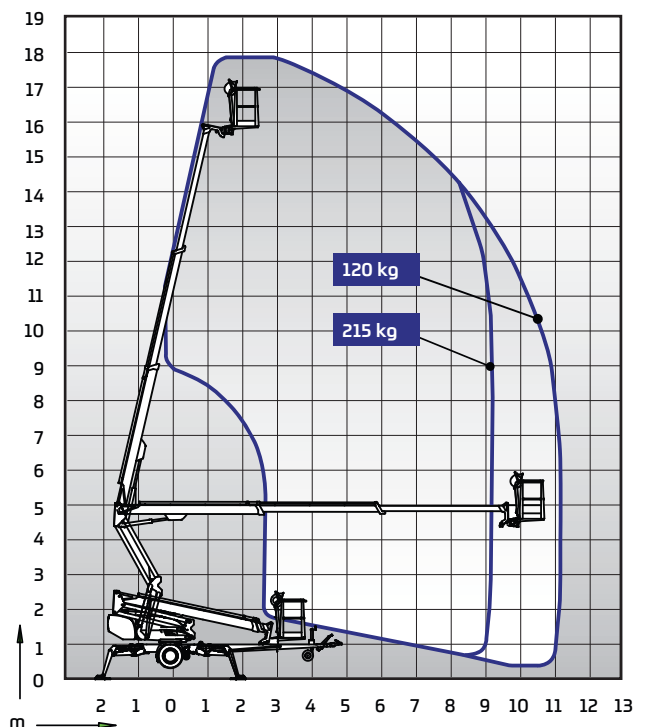

DINOLIFT

UP TO THE JOB

DINOLIFT Oy | Raikkolantie 145 • FI-32210 LOIMAA, FINLAND

Tel: +358 (0)20 1772 400 • E-mail: info@dinolift.com

Read more: www.dinolift.com

Technical specifications are subject to change without prior notice.

©Dinolift Oy | 23.5.2017