

PIAB RTM 20D

Rope Tension Meter



The PIAB RTM 20D can be used in applications where accurate measurement in pre loaded wire ropes is required. Such applications can be stay ropes, suspension ropes, catenary ropes etc. The PIAB RTM 20D is applied direct to the rope and the measured tension value is presented digitally.

Range of Application

The PIAB RTM 20D was designed to swiftly and accurately measure the tension in fixed or stationary ropes or cables i.e. guy wires for masts and/or towers or other guyed constructions.

The PIAB RTM 20D will also be very useful in determining the tension in overhead suspension ropes for railways catenaries.

The PIAB RTM 20D can be used to measure tension forces up to 20 metric ton and for wire ropes with a diameter of up to 38 mm. Thanks to the use of microprocessor technology the PIAB RTM 20D can be calibrated on up to 10 different wire rope dimensions/types. The digital read out display will clearly show the tension of the wire rope selected. No calibration tables are required.

Function

The PIAB RTM 20D is very simple and handy to use. Simply hold and "clip" it to the rope to be tested and use the large hand screw to deflect the rope to a fixed angle.

The resultant force will then affect the load cell and measure

the tension in the wire rope. The resultant signal is digitally processed and displayed in a graduation selected and pre-programmed.

The PIAB RTM 20D can be graduated in kN, klb. or in metric ton.

Safety

The PIAB RTM 20D is a delicate testing instrument for swift, handy and accurate testing of pretensioned stationary ropes.

Thanks to the design of the instrument it can temporarily be overloaded with 100% of its nominal capacity without affecting the accuracy of the instrument.

Tempered outer rope supports and centre clamping jaw give the instrument a long service life with accurate measurements.

The PIAB RTM 20D is delivered in

a robust and light weight transport case (760 x 400 x 170 mm) for easy handling and protection of the instrument.



Technical Data

CAPACITY, MEASUREMENT RANGE

2,0 ton
5,0 ton
10 ton
20 ton

ROPE DIAMETERS

From 6 mm up to 38 mm.

NUMBERS OF ROPES TO BE STORED

Up to 10 (factory programmed).

ACCURACY

2-6% of max. capacity
(dependent on wire rope type and characteristics).

DISPLAY

Digits 12 mm, LCD, 0-19999.

BATTERY

9 V standard, 6LR61 or equivalent.

OPERATING TIME

25 hours.

MATERIAL

Corrosion and weather resistant,
side plates anodised aluminium.

DIMENSION

135x 380 x 685*) mm.

WEIGHT

6,2 kg net.

ENVIROMENT:

TEMPERATURE RANGE

-20 to +60 degrees Centigrade.

PROTECTION CLASS

Conforms to class IP 65
according to IEC 529.
NEMA 13.

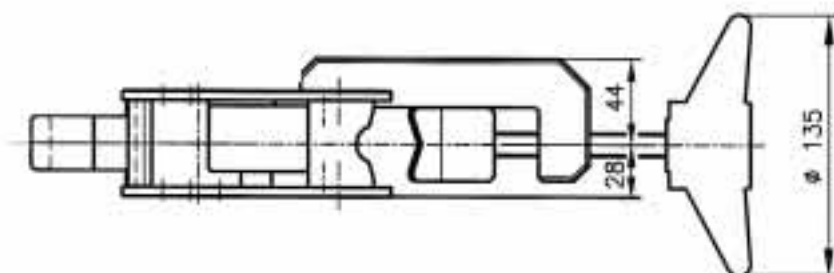
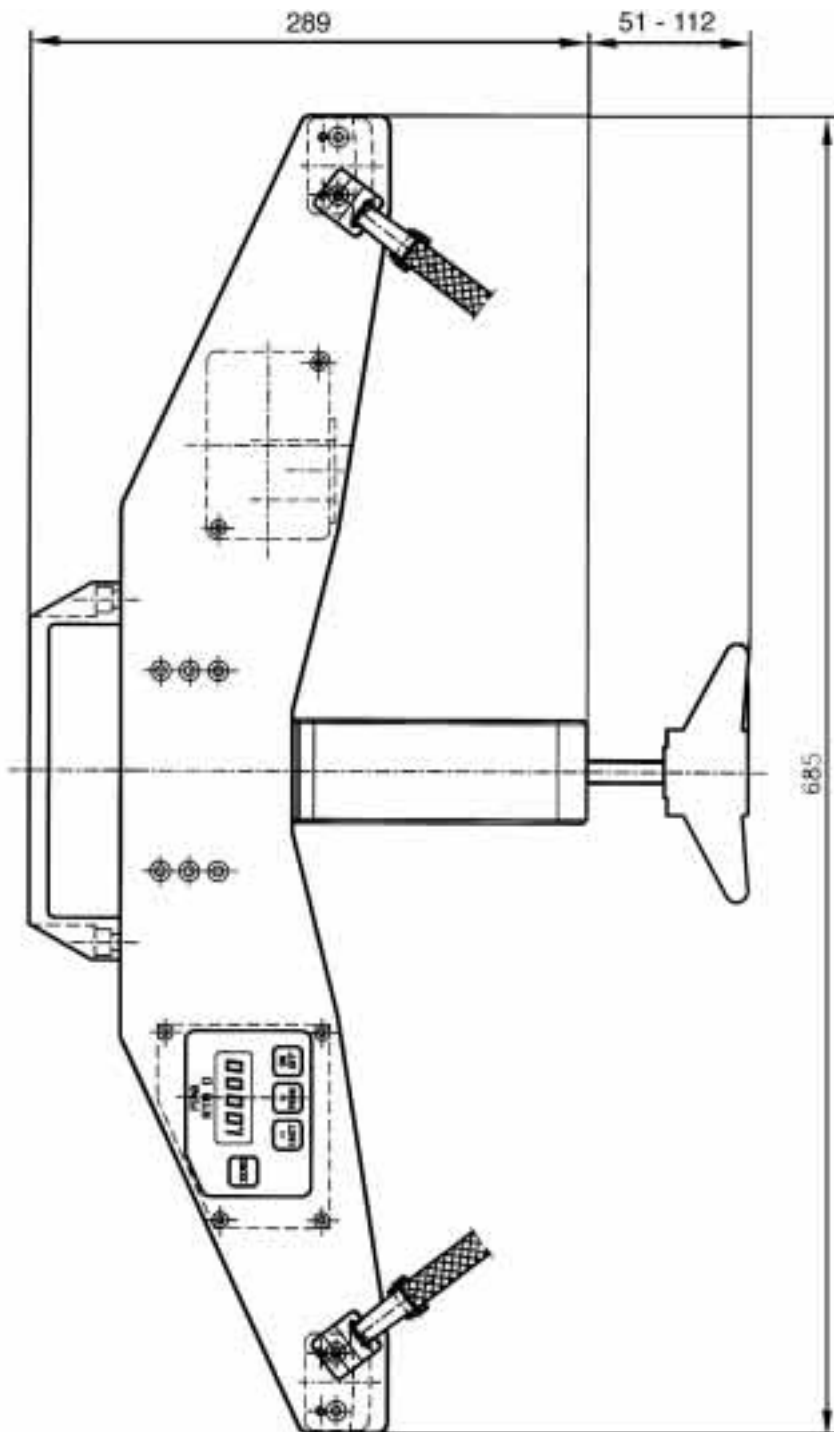

Applications for the **PIAB** RTM 20D



The PIAB RTM 20D is in use when installing/inspecting suspension and catenary ropes.

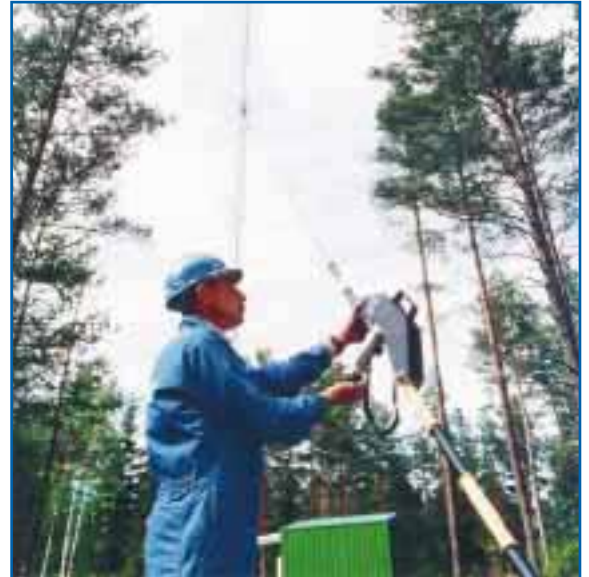

The rapid growth of mobile telephones all over the world need a lot of transmission masts. For accurate operation the masts have to be guyed in a stable position, unaffected by strong winds. Control of tension in the various supporting stay ropes is easily made by using PIAB RTM 20D.

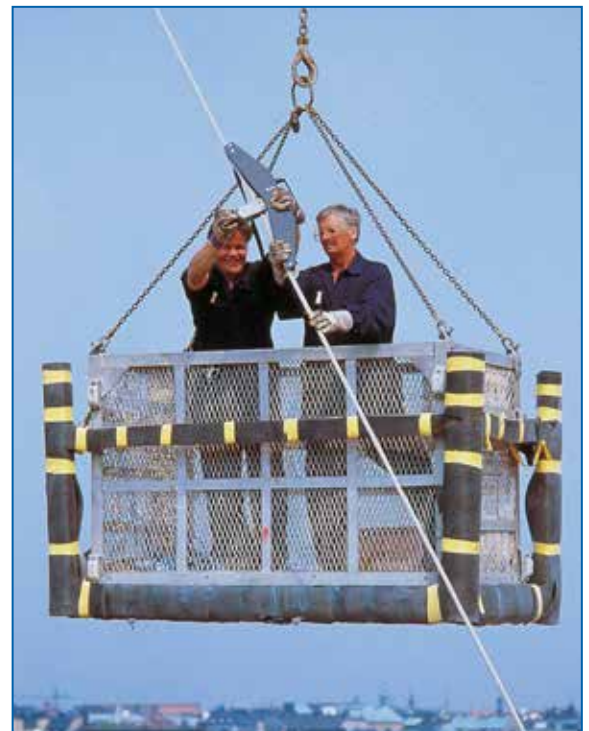

Also when stay ropes are difficult to reach the lightweight RTM 20D is easy to handle. The picture shows control of tension from a crane operated working platform.

9710-1_131024



GIGAsense AB • Stationsvägen 16
SE - 18450 Åkersberga • SWEDEN
Phone: +46 (0)8 540 839 00
e-mail: info@gigasense.se • webb: www.gigasense.se

