



E.H. Wachs
600 Knightsbridge Parkway
Lincolnshire, IL 60069
www.ehwachs.com

CB Boiler Beveler

User's Manual

Product Obsoleted July 2012

E.H. Wachs Part No. 73-MAN-02
Revision 1
January 2013

Copyright © 2013 E.H. Wachs. All rights reserved.
This manual may not be reproduced in whole or in part
without the written consent of E.H. Wachs.

“CB” BOILER TUBE BEVELER

TABLE OF CONTENTS

SECTION I.	SAFETY INSTRUCTIONS	4-7
SECTION II.	CE DECLARATION OF CONFORMITY	8
SECTION III.	SPECIFICATIONS	9
SECTION IV.	SET UP & OPERATING PROCEDURES	11
SECTION v.	PARTS LISTS & EXPLODED VIEW DRAWINGS	13
SECTION VII.	ORDERING INFORMATION.....	16

“CB” BOILER TUBE BEVELER

SECTION I

SAFETY INSTRUCTIONS

The E. H. Wachs Company takes great pride in manufacturing safe, quality products with user safety a priority.

The E.H. Wachs Company recommends that all users comply with the following safety rules and instructions when operating our equipment.



Read the Following thoroughly before proceeding.

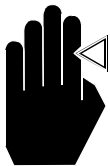

CAUTION

Keep clear of rotating parts during operation. Hands and arms should be kept a minimum of 2' away from moving parts except during starting and stopping.

1. **READ THE OPERATING MANUAL!!** Reading the setup and operating instructions prior to beginning the setup procedures can save valuable time and help prevent injury to operators or damage to machines.
2. **INSPECT MACHINE & ACCESSORIES!** Prior to machine setup physically inspect the machine and it's accessories. Look for worn tool slides, loose bolts or nuts, lubricant leakage, excessive rust, etc. A properly maintained machine can greatly decrease the chances for injury.
3. **ALWAYS READ PLACARDS & LABELS!** All placards, labels and stickers must be clearly legible and in good condition. Replacement labels can be purchased from the manufacturer.
4. **KEEP CLEAR OF ROTATING PARTS!** Keep hands, arms and fingers clear of all rotating or moving parts. Always turn machine off before attempting any adjustments requiring contact with the machine or it's accessories.
5. **SECURE LOOSE CLOTHING & JEWELRY!** Loose fitting clothing, jewelry; long, unbound hair can get caught in the rotating parts on machines. By keeping these things secure or removing them you can greatly reduce the chance for injury.
6. **KEEP WORK AREA CLEAR!** Be sure to keep the work area free of clutter and nonessential materials. Only allow those personnel directly associated with the work being performed to have access to the area if possible.

For your safety and the safety of others, read and understand these safety recommendations and operating instructions before operating.

ALWAYS WEAR PROTECTIVE EQUIPMENT:

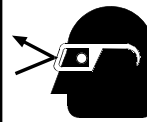

WARNING

Impact resistant eye protection must be worn while operating or working near this tool.

For additional information on eye and face protection, refer to federal OSHA regulations, 29 Code of Federal Regulations, Section 1910.133., Eye and Face Protection and American National Standards Institute, ANSI Z87.1, Occupational and Educational Eye and Face Protection. Z87.1 is available from the American National Standards Institute, Inc., 1430 Broadway, New York, NY 10018.



CAUTION

Personal hearing protection is recommended when operating or working near this tool.

Hearing protectors are required in high noise areas, 85 dBA or greater. The operation of other tools and equipment in the area, reflective surfaces, process noises and resonant structures can substantially contribute to and increase the noise level in the area. For additional information on hearing protection, refer to federal OSHA regulations, 29 Code of Federal Regulations, Section 1910.95, Occupational Noise Exposure and ANSI S12.6 Hearing Protectors.



CAUTION

Some individuals are susceptible to disorders of the hands and arms when exposed to tasks which involve highly repetitive motions and/or vibration. Disorders such as Carpal tunnel syndrome and tendonitis can be caused or aggravated by repetitious, forceful exertions of the hands and arms.

- Use minimum hand grip force.
- Keep wrists straight.
- Avoid prolonged, continuous vibration exposure.
- Avoid repeated bending of wrists and hands.
- Keep hands and arms warm and dry.



CAUTION

Gloves are not a form of protection and should not be worn while operating machinery. Chips and debris which are generated during operation should be disposed of in a safe manner. This should be done with the use of a dust pan and broom to avoid exposure to hands.

SICHERHEITSVORSCHRIFTEN

D

Seit 1883 hat EH Wachs seinen Ruf für Qualität und Zufriedenstellung seiner Kunden aufgebaut. Wachs übernimmt demgemäß die zusätzliche Verantwortung, sein Bestes zu tun, einen möglichst sicheren Umgang mit seiner Ausrüstung zu gewährleisten, und hat daher eine Liste von Sicherheits-Gedächtniszusätzen zusammengestellt, die den Kunden in der Erschaffung einer möglichst sicheren Arbeitsumgebung zu unterstützen. Wir empfehlen, die aufgeführten Vorsichtsmaßnahmen genau zu beachten.



BITTENACHFOLGENDESSORGFÄLTIGVORDEMFORTFAHRENDURCHLESEN!

1. DIE BETRIEBSANLEITUNG LESEN!
Bedienungsmänner können wertvolle Zeit einsparen und Verletzungen und Beschädigungen der Maschine vermeiden, wenn Sie die Aufbau- und Betriebsanleitungen vor dem Aufbau durchlesen.

2. MASCHINE UND ZUSATZGERÄTE ÜBERPRÜFEN!

Vor dem Aufbau der Maschine sollte diese und die Zusatzgeräte physisch überprüft werden. Prüfen Sie, ob abgenutzte Werkzeugschlitten, lockere Bolzen und Schraubenmütter, Schmiermittellagänge, übermäßiger Rost, usw. bestehen. Mit einer ordnungsgemäß gewarteten Maschine kann die Wahrscheinlichkeit eines Unfall stark verringert werden.

3. IMMER INFORMATIONEN UND ETIKETTEN LESEN!

Alle Informationen, Etiketten und Aufkleber müssen gut lesbar und in gutem Zustand sein. Vom Hersteller können Ersatzetiketten angefordert werden.

4. BLEIBEN SIE ROTIERENDEN TEILEN FERN!

Die Hände, Arme und Finger sollten von allen sich drehenden Teilen ferngehalten werden. Vor der Durchführung von Nachstellungen, die Sie in der Nähe mit der Maschine oder deren Zusatzgeräte bringen, die Maschine stets abschalten!

5. WEITE KLEIDUNG UND SCHMUCK BEFESTIGEN!

Weite Kleidung, Schmuck und lange, nicht gelöstes Haar können in den rotierenden Teilen der Maschine hängenbleiben. Die Wahrscheinlichkeit einer Verletzung kann stark herabgesetzt werden, wenn Sie diese Dinge befestigen bzw. abnehmen.

6. ARBEITSBEREICH FREIHALTEN!

Stets darauf achten, daß sich keine unnötigen Materialien, usw. im Arbeitsbereich befinden. Nur dem direkt mit der leistenden Arbeit in Zusammenhang stehenden Personal Zugang zum Arbeitsbereich gestatten!

STETS SCHUTZAUSRÜSTUNG TRAGEN!

WARNUNG!
 Schlagbiefeste Augenschutzbrillen müssen stets bei Betrieb dieses Werkzeugs oder in der Nähe dieses Werkzeugs getragen werden.

ACHTUNG!
 Ein Ohrenschutz muß stets bei Betrieb dieses Werkzeugs oder in der Nähe dieses Werkzeugs getragen werden.

ACHTUNG!
 Manche Personen leiden an Funktionsstörungen der Hände und Arme, wenn sie sich dauernd wiederholende Aufgaben auszuführen haben, die andauernde Bewegungen und/oder Schwingungen mit sich führen. Funktionstörungen, wie beispielsweise Handwurzeln und Sehnenentzündungen, können durch eine sich wiederholende und mit viel Kraft ausgeübte Anwendung der Hände und Arme entweder hervorgerufen oder verschlimmert werden.

ACHTUNG!
 Während des Betriebs von allen rotierenden Teilen Abstand halten. Außer während des An- und Abhaltens sollten Hände und Arme nicht näher als 60 cm an die sich bewegenden Teile herankommen.

ACHTUNG!
 Handschuhe stellen keinen Schutz dar und sollten nicht während des Betriebs der Maschinen getragen werden. Alle während des Betriebs entstandenen Splitter und Überreste sollten auf sichere Art und Weise entsorgt werden. Verwenden Sie dazu eine Kehrschaufel und vermeiden Sie den direkten Kontakt mit den Händen.

CONSIGNE DE SÉCURITÉ

F

Depuis 1883, la société EH Wachs a bâti sa réputation sur la qualité de ses produits et son engagement à satisfaire la clientèle. Conformément à ces principes, Wachs se doit également d'être aussi responsable pour faire de son mieux afin d'assurer l'utilisation la plus sûre de son matériel. Nous avons réuni une liste de rappels de sécurité pour aider à créer un cadre de travail aussi sûr que possible. Nous vous recommandons d'observer scrupuleusement les vérifications préalables indiquées ci-dessous.



Lisez ce qui suit avant d'aller plus avant

1. LIRE LE MANUEL D'UTILISATION !!

En lisant les instructions de réglage et de fonctionnement avant de commencer les procédures de réglage, vous pourrez économiser un temps précieux et vous éviterez aux machinistes de se blesser et d'abîmer les machines.

2. INSPECTER LA MACHINE ET LES ACCESSOIRES !

Avant de régler la machine, inspectez-la à l'oeil nu ainsi que ses accessoires. Recherchez les outils couillants usagés, les boulons ou les écrous desserrés, les fuites de lubrifiant, les dépôts de rouille excessifs, etc. Avec une maintenance adéquate, vous diminuerez sensiblement les risques d'accidents.

3. LIRE SYSTÉMATIQUEMENT LES AFFICHES ET ÉTIQUETTES !

Toutes les affiches, étiquettes et autocollants doivent être parfaitement lisibles et en bon état. Vous pouvez acheter de nouvelles étiquettes auprès du fabricant.

4. SETENIR À DISTANCE DES PIÈCES ROTATIVES !

Tenez vos mains, bras et doigts éloignés de toutes pièces rotatives ou mobiles. Arrêtez toujours la machine avant de tenter de procéder au moindre réglage nécessitant un contact avec la machine ou ses accessoires.

5. PRENDRE GARDE AUX VÊTEMENTS AMPLES ET AUX BIJOUX !

Les vêtements amples, les bijoux, et les cheveux longs qui ne sont pas attachés peuvent être pris dans les pièces rotatives des machines. Enlevez ou attachez ce qui gêne de façon à réduire au maximum les risques d'accident.

6. CONSERVER UNE AIRE DE TRAVAIL DÉGAGÉE !

Ayez bien soin d'enlever les débris et les matériaux qui ne sont pas indispensables. N'autorisez que la présence des employés chargés du travail en cours d'exécution pour dégager au mieux l'aire de travail.

PORTER TOUJOURS UN ÉQUIPEMENT DE PROTECTION

AVERTISSEMENT
 Protégez vos yeux avec des lunettes de sécurité antichoc lorsque cet outil est en marche ou si vous travaillez à proximité.

ATTENTION
 Il est absolument indispensable de vous protéger contre les oreilles lorsque cet outil est en marche ou si vous travaillez à proximité.

ATTENTION
 Certaines personnes sont particulièrement sujettes aux troubles articulaires des mains et des bras lorsqu'elles sont soumises à des tâches nécessitant des gestes très répétitifs ou/et lorsqu'elles sont exposées à des vibrations. Le syndrome du canal carpien et les tendinites peuvent résulter ou être aggravés par des efforts rigoureux des bras et des mains.

ATTENTION
 Tenez-vous à distance des pièces rotatives pendant le fonctionnement. Éloignez vos mains et vos bras d'au moins 60 cm de toute les pièces en mouvement, sauf au démarrage et à l'arrêt.

ATTENTION
 Les gants ne constituent pas une forme de protection et ne doivent pas être portés pour faire fonctionner la machinerie. Les éclats et débris qui sont produits pendant l'opération doivent être éliminés avec précaution. Pour cela, il convient d'utiliser un balai et une pelle pour éviter de les toucher à mains nues.

INSTRUCCIONES DE SEGURIDAD

E

Desde 1883, EH Wachs ha ido forjando una reputación de calidad y compromiso hacia la satisfacción del cliente. De acuerdo con esto, Wachs debe aceptar la responsabilidad adicional de hacer todo lo posible para asegurar el uso seguro de nuestros equipos. Hemos reunido una lista de recordatorios de seguridad para ayudarle a crear el ambiente de trabajo más seguro posible. Recomendamos se observen cuidadosamente los pasos de precaución enumerados en la misma.



Lea lo siguiente detenidamente antes de proceder

1. ¡ LEA EL MANUAL DE OPERACIONES !!

La lectura de las instrucciones de instalación y operación antes de comenzar los procedimientos de instalación puede ahorrarle tiempo valioso y ayudarle a evitar daños a operarios o daño a las máquinas.

2. ¡ INSPECCIONA LA MAQUINA Y LOS ACCESORIOS !

Antes de la instalación de la máquina inspeccione físicamente la máquina y sus accesorios. Busque muecas de herramientas usadas, pernos o tuercas flojas, fugas de lubricante, excesiva corrosión, etc. Una máquina mantenida adecuadamente puede disminuir grandemente las ocasiones de daños.

3. ¡ LEA SIEMPRE LOS LETREROS Y ETIQUETAS !

Todos los letreros, etiquetas y adhesivos deben ser claramente legibles y estar en buenas condiciones. Pueden comprarse etiquetas de repuesto del fabricante.

4. ¡ MANTÉNGASE ALEJADO DE PIEZAS GIRATORIAS !

Mantenga las manos, brazos y dedos alejados de todas las piezas rotatorias o en movimiento. Desconecte siempre la máquina antes de intentar ningún ajuste que requiera entrar en contacto con la máquina o sus accesorios.

5. ¡ ASEGURE LA ROPA SUELTA Y JOYERÍA !

La ropa suelta, joyería; pelo largo y sin atar pueden engancharse en las partes rotatorias de las máquinas. Usted puede reducir grandemente las oportunidades de un accidente asegurando estas cosas o despojándose de ellas.

6. ¡ MANTENGA LIMPIA EL AREA DE TRABAJO !

Asegúrese de mantener el área de trabajo libre de obstáculos y materiales no esenciales. Si es posible permita solamente el acceso al área a aquellas personas directamente asociadas con el trabajo que se está realizando.

USE SIEMPRE EQUIPO PROTECTOR:

AVISO
 Debe usarse protección ocular resistente al impacto mientras se opere o trabaje cerca de esta herramienta.

PRECAUCION
 e requiere en todo momento protección auditiva personal cuando opere o trabaje cerca de esta herramienta.

PRECAUCION
 Algunos individuos son susceptibles a desórdenes de brazos y manos cuando son sometidos a tareas que llevan consigo movimientos altamente repetitivos y/o vibración. Desórdenes tales como el síndrome del túnel carpiano y tenodinitis pueden ser causados o agravados por esfuerzos repetitivos y energicos de las manos y brazos.

PRECAUCION
 Manténgase alejado de las partes giratorias durante la operación. Las manos y los brazos deben mantenerse a una distancia mínima de 60 cm (2') de las partes móviles, excepto al empezar y al detener la operación.

PRECAUCION
 Los guantes no son un medio de protección y no deben usarse al operar la maquinaria. Se deben desechar los fragmentos y escombros generados durante la operación, tomando en cuenta la seguridad de las personas. Esto debe hacerse con una pala para recoger basura y una escoba para evitar el contacto con las manos.

INDICAZIONI PER LA SICUREZZA D'USO

I

Fin dal 1883, l'EH Wachs si è guadagnata una reputazione per quanto riguarda qualità e impegno nella soddisfazione dei clienti. In questa ottica, alla Wachs dobbiamo anche assumerci la responsabilità di fare del nostro meglio per garantire la massima sicurezza d'uso dei nostri apparecchi. Abbiamo preparato un elenco di avvisi di sicurezza come ausilio nel creare il più sicuro ambiente di lavoro possibile. Raccomandiamo di seguire attentamente le precauzioni elencate.



Leggere attentamente quanto segue prima di proseguire.

1. LEGGERE IL MANUALE D'USO !!

Leggere le istruzioni per la messa a punto e l'uso prima di iniziare la messa a punto per risparmiare tempo prezioso e prevenire lesioni e danni al macchinario.

2. CONTROLLARE LA MACCHINA E GLI ACCESSORI !

Prima di mettere a punto la macchina, controllare sia la macchina che gli accessori. Verificare che le slitte portautensili non siano consumate, che i bulloni e i dadi non siano allentati, che non vi siano perdite di lubrificante, ruggine eccessiva, ecc. Una macchina ben mantenuta può ridurre notevolmente le possibilità di danni.

3. LEGGERE SEMPRE TARGHETTE ED ETICHETTE !

Tutte le targhette, le etichette e gli adesivi devono essere chiaramente leggibili e in buone condizioni. Si possono acquistare etichette di ricambio presso il produttore.

4. NON AVVICINARSI A PARTI IN MOVIMENTO !

Tenerne mani, braccia e dita ben lontane da tutte le parti in movimento. Spegnerne sempre la macchina prima di effettuare regolazioni che richiedono il contatto con la macchina o i suoi accessori.

5. FISSARE INDUMENTI E GIOIELLERIA !

Indumenti larghi, gioielli pendenti o lunghi; capelli lunghi sciolti possono rimanere incastrati nelle parti ruotanti sulle macchine. Fissandoli o rimuovendoli si può ridurre notevolmente il rischio di lesioni.

6. MANTENERE L'AREA DI LAVORO SGOMBRA !

Mantenere l'area di lavoro sgombra da materiale non essenziale. Se possibile, consentire l'accesso solamente al personale direttamente interessato nel lavoro svolto.

INDOSSARE SEMPRE INDUMENTI PROTETTIVI:

ATTENZIONE
 Indossare occhiali di sicurezza resistenti all'urto durante l'uso di questo strumento o quando si lavora in sua prossimità.

AVVERTENZA
 Indossare sempre protezione auricolare durante l'uso di questo strumento o quando si lavora in sua prossimità.

AVVERTENZA
 Alcuni individui possono soffrire disturbi alle mani e alle braccia nell'esecuzione di mansioni che comportano movimenti alta-mente ripetitivi e/o vibrazione. Disturbi quali la sindrome del tunnel carpale e tendiniti possono essere causati o aggravati da sforzi ripetuti delle mani e delle braccia.

ATTENZIONE
 Stare lontani da parti rotanti durante l'uso. Tenere mani e braccia ad almeno 60 centimetri di distanza da parti in movimento tranne durante l'avvio e l'arresto.

ATTENZIONE
 I guanti non costituiscono una forma di protezione e non dovrebbero essere indossati durante l'uso delle macchine. Schegge e detriti generati durante l'uso devono essere smaltiti in modo sicuro, usando una palette e una scopa per evitare di toccarli con le mani.

VEILIGHEIDSRICHTLIJNEN

N

Sinds 1883 heeft de firma E.H.Wachs een reputatie opgebouwd voor kwaliteit en heeft zich geëngageerd om vordering te schenken aan de verbruiker. Dienovereenkomstig heeft E.H.Wachs de bijkomende verantwoordelijkheid op zich genomen het uiterste te betrachten om het gebruik van onze apparatuur onder de meest veilige omstandigheden te verzekeren. We hebben een lijst samengesteld van veiligheidsaanmaningen teneinde de meest veilige werkomgeving te scheppen.



We raden aan de hieronder vermelde voorzorgsmaatregelen stipt na te leven. Lees het volgende aandachtig vooraleer verder te gaan.

1. LEES HET BEDRIENINGSHANDBOEK!

Lees de opstel- en bedieningsrichtlijnen vooraleer met de opstelwerkzaamheden te beginnen om kostbare tijd te besparen en om persoonlijke letsels en schade aan de machines te voorkomen.

2. INSPECTEER DE MACHINE EN TOEBEHOREN

Vooraleer de machine op te stellen, inspecteer de machine en haar toebehoren. Kijk uit voor versleten gereedschapsleden, losse bouten en moeren, olie lekken, overmatige roest, enz.. Een goed onderhouden machine kan de kans voor kwetsuren aanzienlijk verminderen.

3. LEES ALTIJD DE PLAAKKAATEN EN ETIKETTEN

Alle plakkaten, etiketten en zelfklevers moeten duidelijk leesbaar zijn en in goede staat. Vervangingsetiketten kunnen bij de fabrikant gekocht worden.

4. HOUD AFSTAND VAN DRAAIENDE ONDERDELEN

Houd handen, armen en vingers weg van alle draaiende of bewegende onderdelen. Schakel de machine uit vooraleer afregelingen te verrichten die contact vereisen met de machine of haar toebehoren.

5. VERMIJD LOSSE KLEDING EN SIERADEN

Los zittende kleding, sieraden, en lang los haar kunnen door draaiende machineonderdelen gegrepen worden. Door ze vast te maken of ze te verwijderen kunt u de kans op verwondingen aanzienlijk verkleinen.

6. HOUD DE WERKRUIMTE VRIJ

Zorg ervoor dat de werkruimte vrij is van rommel en onnodige materialen. Toegang tot de werkruimte moet indien mogelijk enkel verleend worden aan personen die direct betrokken zijn bij het uit te voeren werk.

DRAAG ALTIJD BESCHERMEDE UITRUSTING



WAARSCHUWING

Een veiligheidsbril moet gedragen worden bij het bedienen van dit gereedschap of bij het werken in de buurt van dit gereedschap.



VOORZICHTIG

Persoonlijke gehoorbeschermer is aangeraden bij het bedienen van dit gereedschap of bij het werken in de buurt van dit gereedschap.



VOORZICHTIG

Sommige personen zijn vatbaar voor hand- en arm-letsels wanneer zij blootgesteld zijn aan trillingen of handelingen die hoogst rep-ettieve bewe-gingen ver-gen. Letsels zoals Carpal tunnel syndroom en tendinitis kunnen veroor-zaakt worden of verergeren door rep-ettieve krachtingspanningen van handen en armen.



VOORZICHTIG

Blijf tijdens het bedrijf op veilige afstand van draaiende onderdelen. Houd handen en armen minstens 5 cm weg van bewegende onderdelen, behalve tijdens het starten en stoppen.



VOORZICHTIG

Hand schoenen zijn geen vorm van bescherming en mogen niet worden gedragen terwijl u de machines bedient. Deeltjes en rommel die tijdens het bedrijf ontstaan, moeten op een veilige manier worden opgeruimd. Dit dient te worden gedaan met een bezem en blik om blootstelling van de handen te voorkomen.

SÄKERHETSANVISNINGAR

S

EH Wachs har sedan 1883 etablerat ett gott anseende när det gäller kvalitet och kundtillfredsställelse. Wachs känner sig därför förpliktigt att göra sitt yttersta för att garantera säkrast möjliga användning av Wachs-utrustning.

Vi har ställt samman en lista av säkerhetsanvisningar som ett led i vår strävan att skapa säkrast möjliga arbetsmiljö. Vi rekommenderar att de försiktighetsåtgärder som förtecknats följs noggrant.



Läs igenom nedanstående ordentligt innan du fortsätter.

ANVÄND ALLTID SKYDDSRUSTNING:

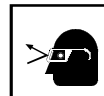

WARNING!

Stötsäkra skyddsglasögon måste bäras vid användning av eller arbete nära detta redskap.



OBS!

Hörselskydd krävs alltid vid användning av eller arbete nära detta redskap.



OBS!

Vissa personer är känsliga för de effekter som kan uppstå i händer och armar när de utför rörelser som är i hög grad repetitiva och/eller utsätts för vibrationer. Tillstånd såsom karpal tunnel syndrom och seninfiammation kan orsakas eller förvärras om händer och armar används för att utföra repetitivt och ansträngande arbete



WARNING!

Undvik roterande delar under drift. Händer och armar bör hållas på minst 0,6 m avstånd från rörliga delar utom när maskinen startas eller slås från



WARNING!

Handskar skyddar inte och bör ej användas medan maskinen körs. Fusor och andra restprodukter som skapas under drift bör kasserats på ett säkert sätt. Använd kvast och sopskyffel för att undvika kontakt med händer.

INSTRUÇÕES DE SEGURANÇA

P

Já desde 1883 que a EH Wachs tem vindo a criar uma reputação de qualidade e um compromisso de satisfação dos consumidores. Nesta linha de conduta, a Wachs tem que assumir a acrescida responsabilidade de fazer o seu melhor para garantir a máxima segurança na utilização dos nossos equipamentos.

Acabamos de compilar uma lista de lembretes de segurança destinados a ajudar na criação de um ambiente de trabalho o mais seguro possível. Aconselhamos que sejam observadas com todo o cuidado as várias fases precauções descritas a seguir.



Ante de continuar, leia com o máximo cuidado o que vai a seguir

1. Leia o Manual de Operações!

A leitura das instruções de montagem e de funcionamento antes de iniciar os procedimentos de montagem poderá poupar um tempo precioso e prevenir ferimentos no operador ou danos nas máquinas.

2. Inspeccione a máquina e respectivos acessórios!

Antes de efectuar a sua montagem, faça uma inspecção física da máquina e seus acessórios. Dirija a sua busca para peças desluzadas, usadas, parafusos e porcas soltos, derrame de lubrificantes, ferrugem excessiva, etc. A manutenção adequada do maquinismo diminuirá os riscos de ferimentos.

3. Leia sempre os cartazes e as etiquetas!

Todos os cartazes, etiquetas e autocolantes deverão ser claramente legíveis e estar em perfeitas condições. Etiquetas acessórias de substituição poderão ser encomendadas directamente do fabricante.

4. Mantenha-se fora do alcance de peças rotatórias!

Mantenha as mãos, braços e dedos fora do alcance de todas as peças rotatórias ou em movimento. Desligue, primeiro, a máquina sempre que tiver de proceder a ajustamentos que requeiram contacto com a máquina ou com as suas peças.

5. Aperte bem a roupa folgada e peças de joalheria!

Roupas folgadas, joalheria e cabelo solto e comprido poderão ser apanhados pelas peças rotatórias das máquinas. Manter estes artigos amarrados ou desfazer-se deles será a melhor maneira de reduzir a possibilidade de ferimentos.

6. Mantenha livre a área de trabalho!

Procure manter a área de trabalho livre de ajustamentos e de materiais não essenciais. O acesso a essa área só deverá ser permitido ao pessoal directamente envolvido no trabalho que estiver a ser executado, tanto quanto possível.

USE SEMPRE EQUIPAMENTO DE PROTECÇÃO:



AVISO!

Sempre que trabalhar com esta ferramenta ou perto dela deverá usar uma protecção para a vista, à prova de choque.



CUIDADO!

É obrigatório usar protecção individual para os ouvidos durante todo o tempo que trabalhar com esta ferramenta ou perto dela.



CUIDADO!

Há pessoas que são propensas a sofrer certos sintomas nas mãos ou nos braços quando expostos a tarefas que envolva movimentos altamente repetitivos, acompanhados ou não de vibrações. Sintomas como, por exemplo, o síndrome do túnel carpeo e a tendinite poderão ser causados ou agravados elo uso esforçado e repetitivo das mãos e dos braços.



ATENÇÃO!

Mantenha distância das partes giratórias durante a operação. Braços e mãos devem ser mantidos a no mínimo 2 pés (60cm) das partes móveis, exceto durante a partida e parada.



ATENÇÃO!

Luvras não são uma forma de protecção e não devem ser utilizadas durante a operação do equipamento. Deve-se desfazer adequadamente das lascas e aparas produzidas durante a uso. Isto deve ser feito com a usa de pá de lixo e vassoura para evitar a cantata com as mãos.

TURVALLISUUSOHJEET

FIN

EH Wachs on tunnettu korkeasta laadusta ja tyytyväisistä asiakkaistaan jo vuodesta 1883. Wachs huolehtii myös siitä, että laitteiden käyttö on mahdollisimman turvallista.

Olemme koonneet tähän turvallisuutta koskevan muistilistan, jota noudattamalla työympäristöstä saadaan mahdollisimman turvallinen. Kehotamme noudattamaan tässä esitettyjä varotoimenpiteitä huolellisesti.

KÄYTÄ AINA SUOJAVÄLINEITÄ:



Lue seuraavat kohdat huolellisesti, ennen kuin jatkat.



VAROITUS

Käytä iskunkestäviä suojalaseja, kun käytät tätä työkalua tai työskentelet sen lähellä.



HUOMAA

Kuulosuojainten käyttöä vaaditaan aina, kun käytät tätä työkalua tai työskentelet sen lähellä.



HUOMAA

Pitkäänajattava altistuminen toistuvalle liikkeelle jaltai tärinälle voi aiheuttaa käsen ja käsivarsien sairauksia joillekin henkilöille. Käsin ja käsivarsiin kohdistuva toi-stuva ja voimakas liike voi aiheuttaa tai pahentaa sairauksia kuten rannekanavairey-hymä ja jännetulehdus.



VAROITUS

Pysyttele loitolla pyörivistä osista käytön aikana. Kädet ja käsivarret tulee pitää vähinään 60 cm:n päässä liikkuvista osista paitsi käynnistyksen ja pysäytyksen aikana.



VAROITUS

Käsineet eivät toimi suojavarusteina, eikä niita tule käyttää koneetta käytettäessä. Käytön aikana syntyvät lastut ja jäte tulee hävittää turvallisella tavalla. Tämä tulee tehdä Rikkalapiota ja harjaa käyttäen käsien altistumisen välttämiseksi.

ANVISNING I SIKKERHED

DK

Siden 1883 har EH Wachs haft ry for deres kvalitet og varetagelse af kundtilfredshed og vil også gøre vort bedste for at sikre, at vore maskiner benyttes på en sikker og forsvarlig måde.

Vi har lavet en liste over påmindelser, der skal bidrage til at skabe det sikrest mulige arbejdsmiljø. Vi anbefaler, at sikkerhedsforanstaltningerne på listen omhyggeligt overholdes.



Læs følgende grundigt, inden der foretages andet

1. LÆS BRUGSANVISNINGEN!!

Hvis man læser anvisningerne i klargøring og drift, inden man begynder at gøre maskinen klar, kan man spare tid og forhindre person- og maskinskade.

2. INSPICÉR MASKINE OG Udstyr!

Inden maskinen gøres klar, skal man inspicere maskinen og udstyret. Se efter slide fittings, løse bolte og møtrikker, olie-lækager, rust osv. Når maskinen holdes i god stand, er der langt mindre risiko for personskade.

3. LÆS ALTID SKILTE OG ETIKETTER!

Alle skilte og etiketter skal være letlæselige og i god stand. Nye skilte og etiketter fås hos forhandleren.

4. HOLD AFSTAND TIL BEVÆGELIGE DELE!

Hold hænder, arme og fingre væk fra alle roterende og bevægelige dele. Man skal altid slukke for maskinen, inden man påbegynder justering, hvor man kommer i kontakt med maskinen eller udstyret.

5. BRUG IKKE LØSTHÆNGENDE TØJ OG SMYKKER!

Løst-hængende tøj, smykker og langt, løst-hængende hår kan blive fanget i maskinens bevægelige dele. Man kan i høj grad nedsætte risikoen for personskade ved ikke at bruge løst-hængende tøj og smykker og ved at samle langt hår oppe på hovedet.

6. HOLD ARBEJDSSTEDET RYDDET!

Arbejdsstedet skal holdes ryddeligt og fri for materialer, der ikke hører til. Uvedkommende personer bør ikke have adgang til arbejdsstedet, hvis det er muligt.

BRUG ALTID BESKYTTELSESDUSTYR:

	ADVARSEL Man skal bruge slag-resistente sikkerhedsbriller, når man arbejder med eller i nærheden af denne maskine.
--	--

	FORSIGTIG Man skal altid bruge hørevern, når man arbejder med eller i nærheden af denne maskine.
--	--

	FORSIGTIG Nogle mennesker er disponeret for lidelser i hænder og arme, når de udsættes for opgaver, der involverer stærkt repetitiv bevægelse og/eller vibration. Sygdomme, såsom karpal-tunnelsyndrom og ten-dinitis, kan forårsages eller forværres af repetitiv, kraftig brug af hænder og arme.
--	---

	FORSIGTIG Hold dig på afstand af roterende dele under drift. Hold hænder og arme mindst 60 cm væk fra bevægelige dele, undtagen ved start og stands fling.
--	--

	FORSIGTIG Handsker er ikke en form for beskyttelse. Gå ikke med handsker, mens maskinen betjenes. Spåner og findelt materiale, som udvikles under drift, skal bortskaffes på forsvarlig måde. Dette skal gøres ved brug af en fejebakke og en kost, for at undgå påvirkning af hænderne.
--	--

ΟΔΗΓΙΕΣ ΑΣΦΑΛΕΙΑΣ

GR

Από το 1883, η EH Wachs έχει δημιουργήσει μια φήμη ποιότητας και δέσμευσης στην ικανοποίηση του πελάτη. Συνεπώς, η Wachs πρέπει να αναλάβει την πρόθετη υποχρέωση να κάνουμε το καλύτερο για να εξασφαλίσουμε την ασφαλέστερη χρήση του εξοπλισμού μας.

Έχουμε καταρτίσει έναν κατάλογο υπομνήσεων ασφαλείας που βοηθούν στη δημιουργία του ασφαλέστερου δυνατού χώρου εργασίας. Συνιστούμε την πιστή εφαρμογή των προληπτικών μέτρων που αναγράφονται παρακάτω.



Πριν προχωρήσετε διαβάστε όλες τις παρακάτω υποδείξεις

1. ΔΙΑΒΑΣΤΕ ΤΟ ΒΙΒΛΙΟ ΟΔΗΓΙΩΝ!

Η ανάγνωση των οδηγιών εγκατάστασης και χειρισμού πριν αρχίσετε τις διαδικασίες εγκατάστασης μπορούν να σας εξοικονομήσουν πολύτιμο χρόνο και να βοηθήσουν στην αποτροπή τραυματισμού των χειριστών ή βλάβης των μηχανών.

2. ΕΠΙΘΕΩΡΗΣΤΕ ΤΗ ΜΗΧΑΝΗ ΑΙ ΤΑ ΕΞΑΡΤΗΜΑΤΑ!

Πριν από την εγκατάσταση της μηχανής επιθεωρήστε τη φυσική κατάσταση της μηχανής και των εξαρτημάτων. ελέγξτε για τυχόν φθορά στις γλίστρες των εργαλείων, λασκαρισμένα μπουλόνια ή παξιμάδια, διαρροή λιπαντικού, υπερβολική σκουριά κτλ. Η μηχανή που συντηρείται κανονικά μπορεί να μειώσει σημαντικά τις πιθανότητες τραυματισμού.

3. ΠΑΝΤΑ ΔΙΑΒΑΣΤΕ ΤΙΣ ΠΙΝΑΚΙΔΕΣ & ΤΙΣ ΕΤΙ ΕΤΕΣ!

Όλες οι πινακίδες, ετικέτες και αυτοκόλλητα πρέπει να διαβάζονται καθαρά και να βρίσκονται σε καλή κατάσταση. Εφεδρικές ετικέτες μπορείτε να αγοράσετε από τον κατασκευαστή.

4. ΑΠΟΜΑ ΡΥΝΘΕΙΤΕ ΑΠΟ ΤΑ ΠΕΡΙΣΤΡΕΦΟΜΕΝΑ ΕΞΑΡΤΗΜΑΤΑ!

ραφήστε χέρια, βραχιόνες και δάχτυλα μακριά από όλα τα περιστρεφόμενα ή κινούμενα εξαρτήματα. Πάντοτε σβήνετε τη μηχανή πριν επιχειρήσετε οποιαδήποτε ρύθμιση που απαιτεί επαφή με τη μηχανή ή τα εξαρτήματά της.

5. ΜΑΖΕΨΤΕ ΤΑ ΛΥΤΑ ΡΟΥΧΑ & ΟΣΜΗΜΑΤΑ!

Τα ρούχα που δεν έχουν καλή εφαρμογή, τα κοσμήματα, τα μακριά, αυτά μαλλιά μπορεί να πιαστούν στα περιστρεφόμενα εξαρτήματα της μηχανής. Στερεώνοντας ή βγάζοντας τα μπορείτε να μειώσετε σημαντικά την πιθανότητα τραυματισμού.

6. ΔΙΑΤΗΡΕΙΤΕ ΕΛΕΥΘΕΡΟ ΤΟ ΧΩΡΟ ΕΡΓΑΣΙΑΣ!

Φροντίστε να διατηρείτε το χώρο εργασίας ελεύθερο από ακαταστασία και επισυώδη υλικά. Επιτρέπετε την είσοδο μόνο στους έχοντας άμεση σχέση με την εκτελούμενη εργασία αν είναι δυνατό.

ΝΑ ΦΟΡΑΤΕ ΠΑΝΤΟΤΕ ΠΡΟΣΤΑΣΕΙΣ ΑΙ ΕΙΔΗ:

	ΠΡΟΕΙΔΟΠΟΙΗΣΗ Να φοράτε ειδή προστασίας των ματιών κατά της πρόσκρουσης όταν χειρίζεστε ή εργάζεστε κοντά στο εργαλείο αυτό.
--	--

	ΠΡΟΣΟΧΗ Χρειάζεται πάντοτε ατομική προστασία των αυτιών όταν χειρίζεστε ή εργάζεστε κοντά στο εργαλείο αυτό.
--	--

	ΠΡΟΣΟΧΗ Μερικά άτομα είναι ευαίσθητα στις διαταραχές των χεριών και των βραχιόνων όταν εκθέτουνται σε εργασίες που συνεπάγονται εξαιρετικά επαναληπτικές κινήσεις και/ή κραδασμούς. Οι διαταραχές όπως το σύνδρομο καρπικής σήραγγας και η τενοντίτιδα μπορεί να προκληθούν ή να επιδεινωθούν από τις επαναληπτικές, ισχυρές εκτάσεις των χεριών και των βραχιόνων.
--	---

"CB" BOILER TUBE BEVELER

SECTION II

EC DECLARATION OF CONFORMITY

Name and address of manufacturer (if different) E.H. Wachs Company
100 Shepard St.
Wheeling, IL 60090 USA

Distributed in the EC by: _____
Business address: _____

We declare that the machine described below conforms with the EHSR of the machinery directive 89/392/EEC and amendments 91/368/EEC, 93/44/EEC and 93/68/EEC

Machine Title Boiler Tube Bevelers

Model Number 73-000-01

Machine Description Portable machinery to end prep pipe.

Serial Number _____

Harmonized Standards Used EN 292, EN 292-2, EN 294, EN 349

PR: EN 982, PR: EN 983, 10/95

Other Safety Standards Used PR: EN 792-1, PR: EN 983, 1050

Name of person authorized to sign on behalf
of the E.H. Wachs Companies Scott Weldon

Position Vice President / CFO

Signature *Scott Weldon*

Date April 1, 1999

SECTION III

SPECIFICATIONS

“CB” BOILER TUBE BEVELER

CB SPECIFICATIONS

Machining Functions:	Boiler tube weld preparation
Capacity:	Machine boiler tube .50" - 2.38" (12.7 - 60.4mm) *1.75" to 2.38" (44.4 to 60.4mm) requires optional tooling
Feed:	Manual ratcheting
Drive:	Pneumatic
Air Requirements:	25 cfm @ 90 psi
Air motor:	.4 HP
Tooling:	High speed steel form tools.
Minimum Panel Opening:	1.5" x 10" (38.1 x 254mm)
Installation:	5 minute set up. Less than 30 seconds change over from tube to tube
Weight:	13 lbs. (29kg)
Controls:	Manual ratcheting tool in-feed. On/Off hand grip with safety
Clamping	Adjustable O.D. clamping .50" to 2.38" (12.7 to 60.5mm)
Standard Equipment:	Basic CB machine, air motor, 6' hose whip w/swivel, cutting head, installation tool, storage case and operating manual.

"A" Dimension:	13"
"B" Dimension:	8.0"
"C" Dimension:	7.2"
"D" Dimension:	1.5"

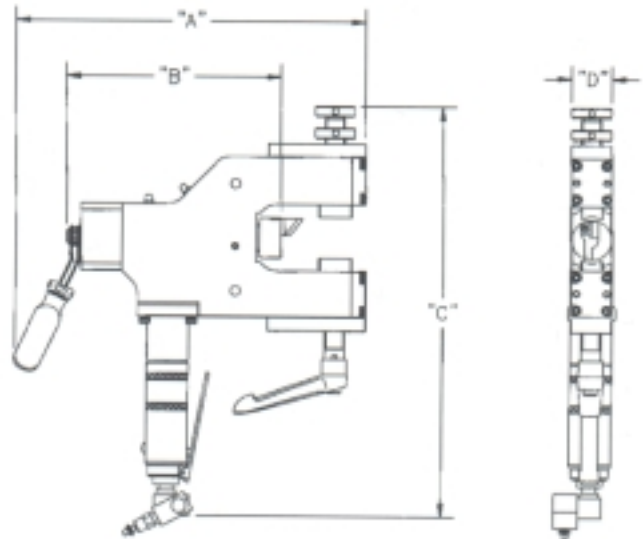

SECTION IV

**SET UP
&
OPERATING
PROCEDURES**

“CB” BOILER TUBE BEVELER

SAFETY INSTRUCTIONS

SAFETY INSTRUCTIONS

READ AND UNDERSTAND ALL SAFETY INSTRUCTIONS BEFORE ATTEMPTING TO SETUP OR OPERATE ANY MACHINE TOOL!

INSPECT MACHINE & ACCESSORIES FOR WEAR AND DAMAGE

KEEP CLEAR OF ROTATING PARTS

HEED ALL WARNINGS AND CAUTIONS

SECURE LOOSE CLOTHING & JEWELRY

KEEP WORK AREA CLEAR

ALWAYS DISCONNECT POWER SOURCE WHEN BEVEL IS COMPLETED

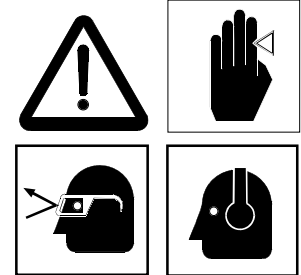

TOOL BIT INSTALLATION

Loosen tool bit wedge screw with the provided hex key. Slide tool bit into desired position and snug the tool bit wedge screw A.

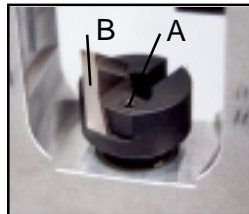

TOOL BIT (B)	PART #
37 1/2 DEGREE BEVEL TOOL BIT	70-7000-00

SET UP AND OPERATION

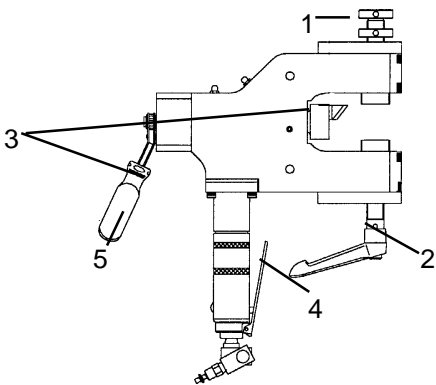

1. Rotate sizing clamp knob clockwise to center machine.
2. Check center by tensioning main clamp.
3. Using the Feed Ratchet, rotate tool bit feed disk in and look for an equal gap from tool bit around the work O.D. Readjust sizing clamp as need.
4. Connect power source and squeeze air motor trigger to begin tool bit rotation.
5. Feed tool bit into work by rotating the feed ratchet clockwise until desired bevel is achieved.
6. Switch directional lever on feed ratchet to rotate counterclockwise and retract tool bit. Release air motor trigger and disconnect power source.

COMPONENTS

- A. SIZING CLAMP
- B. CLAMP PADS
- C. MAIN CLAMP
- D. TOOL BIT DISK
- E. FEED RATCHET
- F. TRIGGER

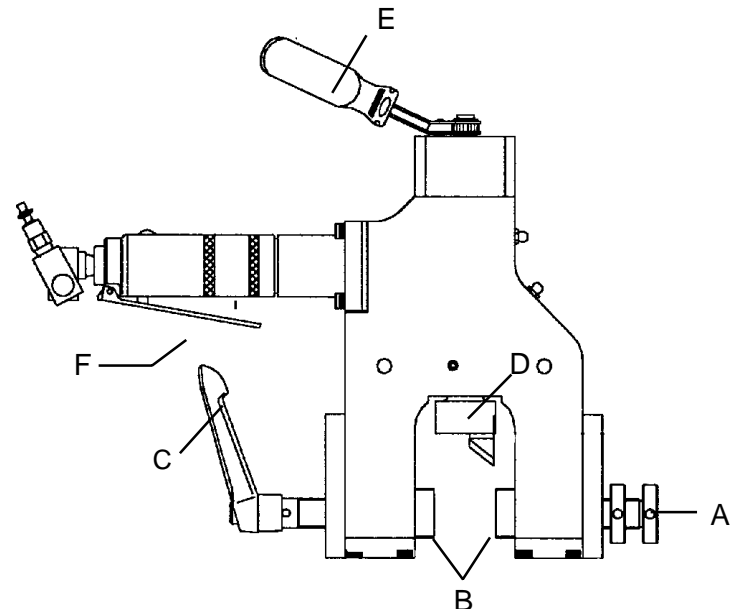

SECTION V

**PARTS LISTS
&
EXPLODED VIEW
DRAWINGS**

CB BOILER TUBE BEVELERS

CB Beveler Bill of Material

Part # 73-000-00

Ref.#	Part #	Qty.	Description	Ref.#	Part #	Qty.	Description
005	73-005-00	1	SHAFT, SPINDLE	031-01	73-031-01	2	NUT, 1/4-28 L. H.
006	73-006-00	1	BEVEL GEAR, RING	031-02	73-031-02	1	WASHER, 1/4 " SERRATE
007	73-007-00	1	GEAR, PINION	032	73-032-00	1	BEARING, CONTROL
008	73-008-00	1	RING, FEED	033	73-033-00	1	O-RING, 199 BUNA-N
009	73-009-00	1	SCREW, FEED	034	73-034-00	1	WRENCH, 3/8" BOX RAT
010	73-010-00	1	CAP, FEED	026	70-026-00	1	MOTOR, AIR
011	73-011-00	1	ADAPTER, AIR MOTOR	N/S	73-035-04	2	.004" AIR MOTOR SHIM
012	73-012-00	1	MCH BUSING, SPINDLE	N/S	73-035-08	1	.008" AIR MOTOR SHIM
013	73-013-00	1	BUSHING, REAR SPINDL	22	70-022-00	1	WEDGE
014	73-014-00	1	BUSHING, FEED	023	70-023-00	1	SCREW, DIFFERENTIAL
015	73-015-00	1	FRAME	N/S	73-036-00	1	FOAM, CASE*
016	73-016-00	2	PLATE, CLAMP SAW	N/S	16-082-00	1	CASE*
017	73-017-00	2	PLATE, CLAMP PAD	037	73-037-00	1	SWIVEL, 1/4"
018	73-018-00	2	CLAMP PAD	038	73-038-00	1	COUPLING, DRIVE
019	73-019-00	1	SCREW, FIXED CLAMP	N/S	73-039-00	1	LABEL, CASE
020	73-020-00	1	NUT, CLAMP PAD, JAM	040	73-040-00	1	HOSE, ASSM, 1/4" X 6'
021	73-021-00	1	SCREW, ADJUSTABLE	007	74-007-05	2	WASHER, .005" THK.
022-01	73-022-01	10	.001" SHIM CL PAD	041	73-041-00	2	DECAL, AMERICAN
022-05	73-022-05	4	.005" SHIM CL PAD	042	73-042-00	2	DECAL, METRIC
022-10	73-022-10	4	.010" SHIM CL PAD	1	90-054-05	1	SSS, 1/4-20 x 1/2
055	19-055-00	1	LEVER, CHECK ADJ	2	90-050-17	4	SHCS, 1/4-20 x 1-3/4
855	19-855-00	1	LEVER	3	90-028-01	1	SHPP, 1/8 DRY SEAL
023	73-023-00	2	WASHER, THRUST	4	90-500-05	2	GRSE.FTG. 1/4-28 STR
028	73-028-01	1	WASHER, THRUST	5	90-050-07	12	SHCS, 1/4-20 x 3/4
025	73-025-00	1	SEAL 1.13 x .88 x .13	6	90-040-56	8	SHCS, 10-32 x 5/8
026	73-026-00	2	BEARING	7	90-046-07	4	PIN, 3/16 X 3/4 DOWEL
027-01	73-027-01	1	RING, SNAP	8	90-050-12	2	SHCS, 1/4-20 X 1-1/4
027-02	73-027-02	1	RING, BEVELED RETAIN	9	90-054-02	2	SSS, 1/4-20 X 1/4
027-03	73-027-03	1	RING, INT. RETAINING	10	90-046-05	1	PIN, 3/16 X 1/2 DOWEL
027-04	73-027-04	1	RING, EXT. RETAINING	11	90-050-10	4	SHCS, 1/4-20 X 1
027-05	73-027-05	1	RING, EXT. RETAINING	12	90-064-03	1	SSS, 5/16-18 X 3/8
028	73-028-00	1	BEARING, THRUST	N/S	90-800-22	1	WRENCH, HEX 1/8 S.ARM
029	73-029-00	1	BEARING, NEEDLE RLR	14	90-046-58	1	PIN, ROLL 3/16 X 5/8
030-01	73-030-01	1	BEARING, THRUST	15	90-055-54	1	WASHER, AN 1/4
030-02	73-030-02	2	WASHER, THRUST	N/S	90-800-22	1	WRENCH, HEX 1/8 S.ARM

To place an order or to get more detailed information on any E.H. Wachs products, call us at:
1-800-323-8185.

ORDERING REPLACEMENT PARTS

Please use parts list provided in manual. Have part description and part number of required replacement part or parts to help expedite order and insure proper parts are being ordered.

REPAIR INFORMATION

Please call E.H. Wachs Company prior to returning any equipment for repair. We will advise you of shipping and handling. Please enclose with equipment to be repaired your name, address, phone number and a brief description of problem or work to be done or estimated.

All repair work done at our plant will be estimated and the customer advised of cost and time required to complete repair.

WARRANTY INFORMATION

Enclosed with the manual is a warranty card. Please fill out the registration card and return to E.H. Wachs. Retain the owners registration record and warranty card for your information.

RETURN GOODS ADDRESS

E.H. Wachs Company
600 Knightsbridge Parkway
Lincolnshire, IL 60069

Call or Write:



E.H. Wachs Company
600 Knightsbridge Parkway
Lincolnshire, IL 60069

847-537-8800

FAX: 847-520-1147 • 847-520-1168

Toll-Free: 1-800-323-8185

www.wachsco.com

	PIPE & TUBE	
	CUT-OFF MACHINES	
Model: CB BEVELER		
Enter Your Machines Serial Number Here For Proper Record Keeping and Ordering Reference.		

WACHS

BOILER TUBE BEVELERS

“SB”

I.D. mount. Weld prepare boiler tubes from .69" I.D. to 2.25" O.D. (12.7mm to 46.2mm) up to .375" (9.5mm) wall quickly and accurately.

“MB”

I.D. mount. Weld prepare boiler tubes from 1.0" I.D. to 3.5" O.D. (25.4mm to 88.9mm) up to .425" (10.7mm) wall quickly and accurately.

“LB”

Weld prepare boiler tubes from 1.16" I.D. to 4.5" O.D. (29.4mm to 114.3mm) up to .500" (12.2mm) wall quickly and accurately.

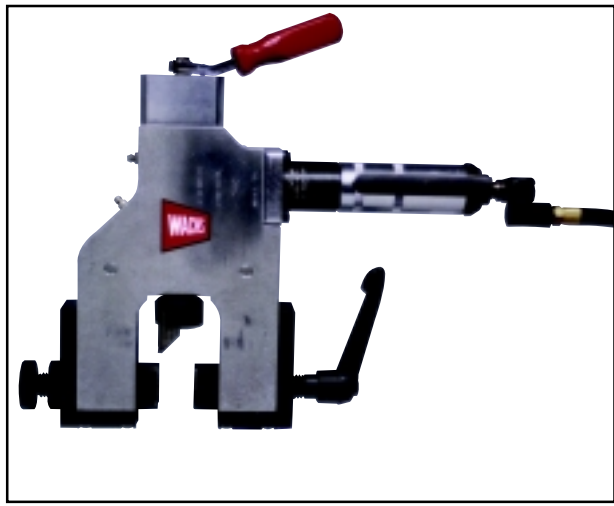
“CB”

O.D. mount from one side of the tube wall requiring only a 1.5" wide x 10" (38.1 to 254mm) opening. Weld prepare .50" to 2.38".

WACHS**E.H. WACHS COMPANY**

100 Shepard St., Wheeling, Illinois 60090
TEL: (847) 537-8800 Worldwide • (800) 323-8185 USA
FAX: (847) 520-1147 • www.wachSCO.com



600 Knightsbridge Parkway • Lincolnshire, IL 60069
847-537-8800 • www.ehwachs.com