

# Operating Instructions for the

# **novopress**

## SYSTEM TOOLS

## HSBL

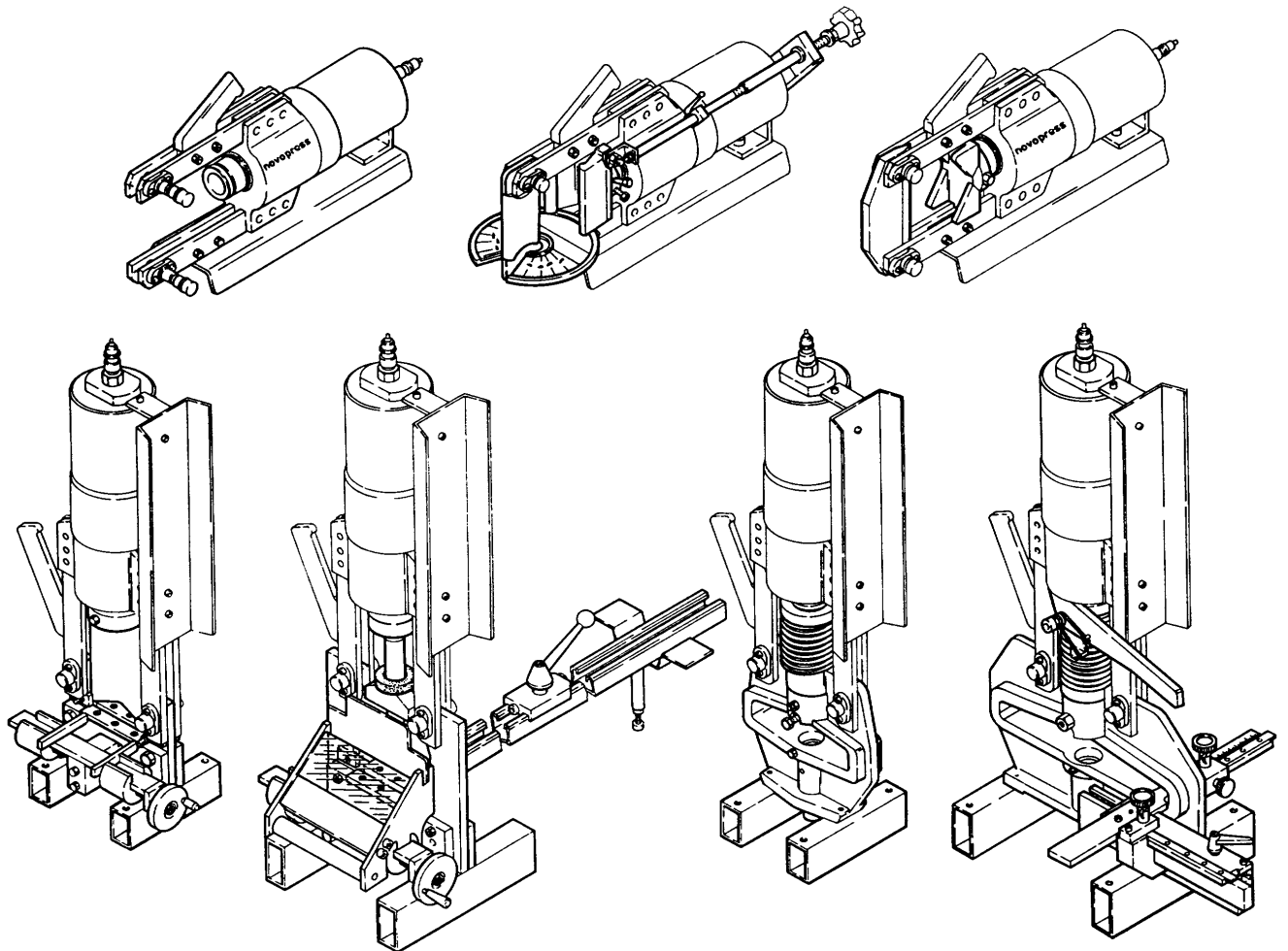

16555

## Contents

	<b>Page</b>
CE Conformity Attestation	
Safety regulations	
Working cylinder	1
HSBL - Cable cutters, Order No. 1081	3
HSBL - Cutting tool 120, Order No. 2350	4
HSBL - Cutting tool 160, Order No. 7020	7
HSBL - Plying iron with angle indicator, Order No. 1179	10
HSBL - Punching tool 120, Order No. 1118	14
HSBL - Punching tool 160, Order No. 7050	19

## CE - KONFORMITÄTSERKLÄRUNG

entsprechend EG-Richtlinie  
98/37/EG

Novopress GmbH & Co KG  
Scharnhorststr. 1  
D-41460 Neuss

**Systemwerkzeuge**  
**HSBL**

Ser-nr: .....

1. EN 294, EN 349, EN ISO 12100-1, EN ISO 12100-2

Hiermit erklären wir, daß die nachfolgend bezeichnete Maschine aufgrund Ihrer Konzipierung und Bauart sowie der von uns in Verkehr gebrachten Ausführung den einschlägigen grundlegenden Sicherheits- und Gesundheitsanforderungen entspricht. Bei einer nicht bestimmungsgemäßen Anwendung der Maschine oder bei einer nicht mit uns abgestimmten Änderung der Maschine verliert diese Erklärung ihre Gültigkeit.

Die Konformitätserklärung ist nur gültig, wenn die Maschine mit dem Hydraulikaggregat HA1ES oder HA3 betrieben wird.

**Angewandte harmonisierte Normen, insbesondere:**  
siehe Punkt 1

We hereby declare that with respect to its design and construction the machine stated below and the model thereof which we have brought into circulation conform with the applicable basic requirements on health and safety.

Any use of the machine other than that for which it is intended and any modification made thereto without our consent shall render this declaration null and void.

This declaration of conformity shall only be valid if the machine is operated with hydraulic unit HA1ES or HA3.

**Applied harmonized standards, in particular:**  
see Item 1 above

Nous déclarons par la présente que par sa conception et son type ainsi que par l'exécution que nous avons mise sur le marché, la machine désignée ci-après répond aux exigences de sécurité et de prévention de la santé applicables.

La présente déclaration perd sa validité si la machine n'est pas utilisée conformément aux instructions ou dans le cas d'une modification de la machine à laquelle nous n'avons pas donné notre accord.

La déclaration de conformité n'est valable que si la machine est utilisée avec le groupe hydraulique HA1ES ou HA3.

**Normes harmonisées utilisées, en particulier :**  
voir point 1

Hiermede verklaren wij, dat de hierna genoemde machine op grond van haar constructie en type alsmede de door ons in de handel gebrachte uitvoering aan de desbetreffende fundamentele eisen ten aanzien van de veiligheid en de gezondheid voldoet.

Wordt de machine niet overeenkomstig haar bestemming gebruikt of worden hieraan niet met ons overeengekomen wijzigingen aangebracht, dan verliest deze verklaring haar geldigheid.

De conformiteitsverklaring is slechts geldig, indien de machine met het hydraulische aggregaat HA1ES of HA3 wordt aangedreven.

**Toegepaste geharmoniseerde normen, in het bijzonder:**  
zie punt 1

Datum / Herstellerunterschrift: 01.08.05  
Angaben zum Unterzeichner:



Geschäftsführer

Con la presente declaramos que la máquina denominada a continuación, por su concepto y por su construcción, cumple con los requisitos fundamentales de seguridad y sanidad en vigor. Lo dicho aplica exclusivamente a la máquina en su versión original, tal y cual ha sido fabricada por nosotros.

El empleo inapropiado de la misma, así como cualquier modificación ejecutada sin nuestra intervención hace que esta declaración pierda su validez.

Para que esta declaración de conformidad tenga validez, la máquina se habrá de operar categóricamente con un grupo hidráulico tipo HA1ES o tipo HA3.

**Normas armonizadas aplicadas, en particular:**

véase bajo el punto 1

Si dichiara che la macchina appresso descritta soddisfa, per concetto, tipo e modello messo in commercio, le esigenze di base di sicurezza e sanità relative a tali apparecchiature.

In caso di uso non appropriato della macchina o in caso di una sua modifica eseguita senza il nostro accordo, questa dichiarazione non ha più effetto.

La dichiarazione di conformità è valida solo se la macchina è messa in funzione con il gruppo idraulico HA1ES o HA3.

**Norme armonizzate applicate, in particolare**

vedi punto 1

Härmed försäkrar vi att nedan nämnd maskin motsvarar de tillämpliga och principiella säkerhets- och hälsoföreskrifterna både gällande koncipieringen och konstruktionen samt gällande den av oss sålda modellen.

Används denna maskin inte enligt anvisningarna eller förändras maskinen på ett sätt som vi inte har godkänt, gäller denna försäkran ej.

Konformitetsförsäkran gäller endast om maskinen drivs med hydraulikkaggregat HA1ES eller HA3.

**Tillämpade harmoniserade normer, i synnerhet:**

se punkt 1

Täten vakuutamme, että seuraavassa nimetty kone vastaa suunnittelunsa, rakenteensa sekä meidän taholtamme liikenteeseen päästetyn mallinsa puolesta asiaankuuluvia perustavaa laatua olevia turvallisuus- ja terveystämääräyksiä.

Jos konetta ei käytetä määräysten mukaisesti tai jos koneeseen tehdään muutos ilman meidän suostumustamme ei tämä selvitys enää päde.

Standardinmukaisuusselvitys on vain silloin voimassa, kun konetta käytetään hydraulisen yksikön HA1ES tai HA3 kanssa.

**Käytetyt harmonisoidut standardit, varsinkin:**

katso Kohta 1

Herved erklærer vi at den i det følgende betegnede maskinen på grunn av dens konsipering og konstruksjon samt utførelsen som vi har brakt på markedet tilsvarende de respektive grunnleggende krav til sikkerhet og helse.

Ved en bruk av maskinen som ikke er formålstjenlig eller ved en endring av maskinen som ikke er avstemt med oss mister denne erklæringen sin gyldighet.

Konformitetserklæringen er bare gyldig hvis maskinen drives med hydraulikkaggregatet HA1ES eller HA3.

**Benyttede harmoniserte standarder, særlig:**

se punkt 1

Declaramos pelo presente, que a máquina a seguir designada, na sua planificação e construção, assim como no modelo por nós comercializado, obedece às respectivas exigências fundamentais de segurança e de saúde.

A presente declaração perde a validade em caso de uso impróprio da máquina ou em caso de modificações na máquina, que não tenham sido acordadas antecipadamente connosco.

A declaração de conformidade é válida somente quando a máquina é accionada com o agregado hidráulico HA1ES ou HA3.

**Normas harmonizadas aplicadas, especialmente:**

vide parágrafo 1

## **GENERAL SAFETY REGULATIONS**

### **Read all safety regulations and instructions!**

1. Keep the place of work clean.  
Disorderly work-places and work-benches invite accidents.  
Ensure that lighting is good.
2. Keep children away.  
Do not allow unauthorised persons to touch the device or the cable.  
Keep unauthorised persons away from your place of work.
3. Wear suitable working clothing.  
Do not wear any wide clothes nor jewellery - they may get caught up in moving parts.  
When working in the open it is recommended that you wear rubber gloves and non-slip footwear. Wear a hair- net if you have long hair.
4. Always be alert.  
Only use a device after having been instructed in its operation.  
Concentrate on your work. Proceed sensibly.  
Do not use the device when you are distracted.
5. Do not lean too far forward. Avoid abnormal stance.  
Make sure that you have a secure standing position, and maintain balance at all times.
6. Leave safety devices where they belong.
7. Hand tools may not be installed as fixtures.
8. Repair and maintenance.  
Have repairs and maintenance work carried out in an authorised NOVOPRESS specialist workshop.  
Only use original and identical NOVOPRESS spare parts.  
We reject all responsibility and liability for work carried out by third- party personnel.

## SAFETY INSTRUCTIONS FOR HYDRAULIC EQUIPMENT

1. Please read the operating instructions.  
Acquaint yourself with the hydraulic equipment.
2. Provide the equipment with the necessary care.  
Always keep the equipment in operational condition.  
Cleanness is an essential requirement for good and safe working.
3. Switch off the electric power supply to the hydraulic equipment,
  - when the equipment is not in use
  - when maintenance work is to be carried out.
4. Avoid unintentional switching - on.  
Keep hands and feet away from the switch when the equipment is not being used.
5. Do not use the equipment in a manner in contravention of the instructions.  
Never carry the equipment by the pipe or pull on the pipe.  
Protect the piping from heat, oil, sharp edges and high levels of weight strain.
6. Use only piping, fittings and accessories which have been designed for the operating pressure of the hydraulic unit.  
**BURSTING PRESSURE OR TEST PRESSURE IS NOT OPERATING PRESSURE!**  
Avoid squashing or bending of the piping.  
Piping must not be painted over.
7. Replace the hydraulic piping
  - when cracks, squashed or bent points are to be seen
  - when blistering is established
  - when hydraulic fluid escapes
  - when pipe fittings are damaged
  - when discolouration is established on the outer layer, e.g. due to the influence of solvents.
8. The hydraulic fluid used in the system is kerosene-based.  
This requires particular care and attention.
  - Avoid continuous contact with the skin
  - ensure that the hydraulic fluid does not get into the eyes or mouth.Hydraulic pipes have to be replaced after 5 years of usage, despite of the circumstance that no damages should be remarkable.
9. The equipment must not be operated, if it has leaks and there is a danger of hydraulic fluid coming into contact with persons, open fire, heating equipment, electric cabling, ground water, foods and other substances which are intended for human consumption.
10. Hydraulic units with petrol engines
  - must not be operated in closed rooms, due to the **DANGER OF INTOXICATION!**
  - do not pour in petrol while the motor is running or in the vicinity of open fire. **DANGER OF EXPLOSION!**

## HSBL SERIES HYDRAULIC SYSTEM TOOLS

### HSBL Hydraulic Cylinder, Order No. 2420

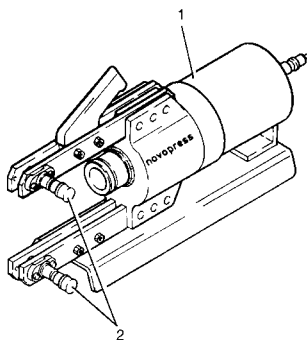

#### Operative Range

This cylinder has been designed to work with a pressure of max. 150 bar (2200 psi) and is used with HSBL-Series tools.

The cylinder (1) is fastened with a bolt (2) to the tool being used. The bolts (2) are situated at the end of the cylinder spars.

The cylinder can be driven by the NOVOPRESS hydraulic unit; we recommend the HA 1 hydraulic system with an electric motor.

#### Technical specifications

Length	620 mm	( 24.4"
Width	140 mm	(5.5")
Height	365 mm	(14.4")
Stroke length	120 mm	(4.7")
Weight	21 kg	(46 lb)
Max. working pressure	150 bar	(2200 psi)
Power	150 kN	(15 tonf)

#### Operation

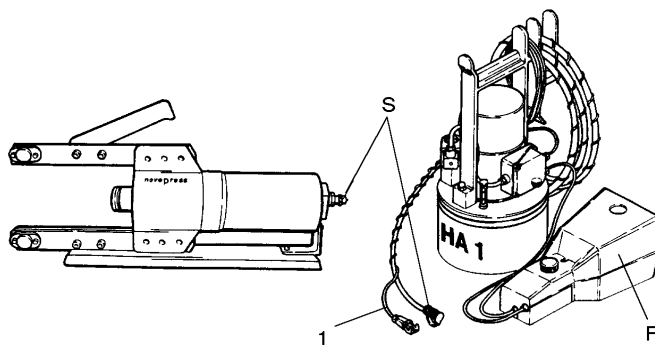

Connect the control conduit (1) of the hydraulic unit to the plug on the device (HSBL cylinder).

#### Note:

*The hydraulic unit can only be operated if the plug is connected.*

The cylinder is attached to the HA hydraulic system with a rapid-action coupling (S)

### Rapid-action coupling

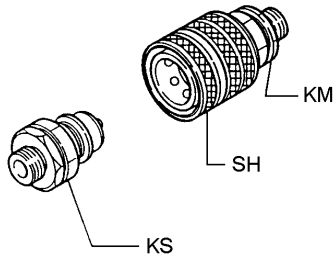

#### Coupling

Hold the coupling sleeve (KM) at the sliding sleeve (SH) and slide onto the coupling plug (KS).

#### Uncoupling

Hold the coupling sleeve (KM) at the sliding sleeve (SH) and pull off of the coupling plug (KS).

To deaerate the cylinder carry out a few idle strokes. The hydraulic unit must be on a higher level than the cylinder during this procedure.

**ATTENTION !** WHEN ATTACHING AND REMOVING THE SYSTEM TOOLS OR CARRYING OUT MAINTENANCE WORK, UNCOUPLE THE HYDRAULIC UNIT OR DISCONNECT IT FROM THE MAINS!

### Maintenance

**ATTENTION !**  
UNCOUPLE THE HYDRAULIC UNIT OR DISCONNECT IT FROM THE MAINS BEFORE CARRYING OUT MAINTENANCE WORK.

Every week:

- Clean and grease piston rod.
- Clean and grease fixing bolts.

Every month:

Check cylinder for leakage. If necessary, send in for repair.



## HSBL CABLE CUTTERS, Order No. 1081

### Operative range

Copper and aluminium cables of up to a diameter of 120 mm (4 3/4") can be cut with these cutters.

### Technical specifications:

Width:	140 mm	(5.5")
Length with working cylinder	650 mm	(25.6")
Height	350 mm	(13,8")
Weight	3 kg	(6.6 lb)

### ATTENTION !

BEFORE ATTACHING AND REMOVING THE SYSTEM TOOLS OR CARRYING OUT MAINTENANCE WORK, UNCOUPLE THE HYDRAULIC UNIT OR DISCONNECT IT FROM THE MAINS!

### Attaching the Tools:

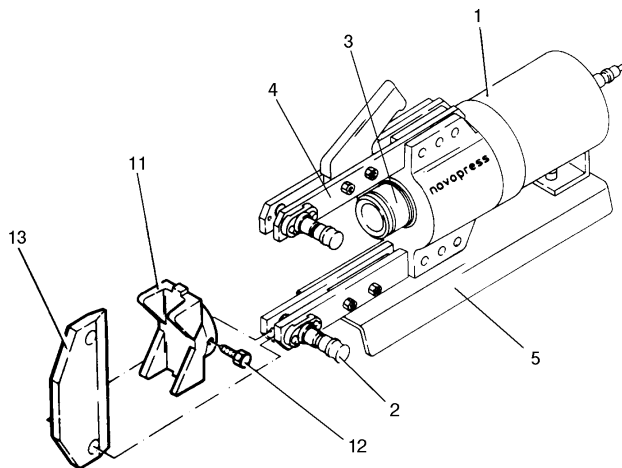

Place the HSBL cylinder (1) on the stand (5). Slide the pressure plate (Order No. 1098) (11) on to the piston rod (3) and tighten the fastening screw. Slide the cutting edge (Order No. 1097) (13) between the cylinder spars (4) and fasten using the bolts (2).

### Operation

The mouth can be opened by pulling out a fixing bolt (2) and by tilting out the edge (13). This makes it easier to put in longer cable pieces.

The HA hydraulic unit is switched on and off by using the foot switch on the unit.

### Accessories

A specially ground edge is available for cutting reinforced cables (Order No. 4121)

### Maintenance

### ATTENTION !

UNCOUPLE THE HYDRAULIC UNIT OR DISCONNECT IT FROM THE MAINS BEFORE CARRYING OUT MAINTENANCE WORK.

In case of wear or damage: Replace or regrind cutting edge.

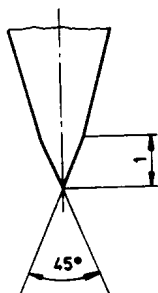

### Regrinding

The cutting edge can be regrind up to a max. of 4 mm. When the edge is reground, care should be taken that the edge remains parallel to the edge's back.

The cutting edge and the pressure piece of the cable cutters are subject to wear and tear. When changing the cutting edge, the pressure piece should also be changed.

## **HSBL - 120 Cutting Tool, Order No. 2350**

### **Operative range**

You can cut the following with this tool:

- copper and aluminium rails of up to 120 x 10 mm (4 3/4" x 3/8" ) with a max. strength of 250 N/mm<sup>2</sup> (36 250 psi).
- steel rails of up to 120 x 6 mm (4 3/4" x 1/4") with a max. strength of 370 N/mm<sup>2</sup> (53 650 psi).  
Waste consists of a piece as wide as the cutting edge.

### **Technical specifications**

Width:	without vice	210	mm	( 8.3")
	with vice	340	mm	(13.4")
Depth:	without vice	200	mm	(8")
	with vice	225	mm	(8.8")
Height with working cylinder		785	mm	(31")
Weight:	without vice	12,0	kg	(26.4 lb)
	vice	3,0	kg	(6.6 lb)

### **Operation**

There are four holes in the bases of the HSBL cutting tool 120. Use these holes to fasten the tool to a work bench.

The working cylinder (1), Order No. 2420, should be attached to the cutting tool as follows:

1. Place the protective device with the cutter blade (10) into the stand (13).
2. Pull out the fixing bolts (2) on the cylinder (1) as far as possible.
3. Slide the cylinder (1) with the spars (4) on to the cutting tool's spars. Align the holes on the cutting tool with the fixing bolts (2) on the working cylinder (1).
4. Slide the fixing bolts (2) in as far as possible.
5. Push the base plate (11) with the knurled screws (12) onto the piston rod (3).
6. Fix the base plate (11) to the piston rod (3) using the knurled screws (12). The points of the knurled screws (12) must enter the groove in the piston rod (3).
7. Connect the working cylinder (1) and the HA hydraulic unit using the rapid-action coupling and the plug (see page 2).

To deaerate the cylinder, carry out a few idle strokes. The hydraulic unit should be on a higher level than the working cylinder when deaerating.

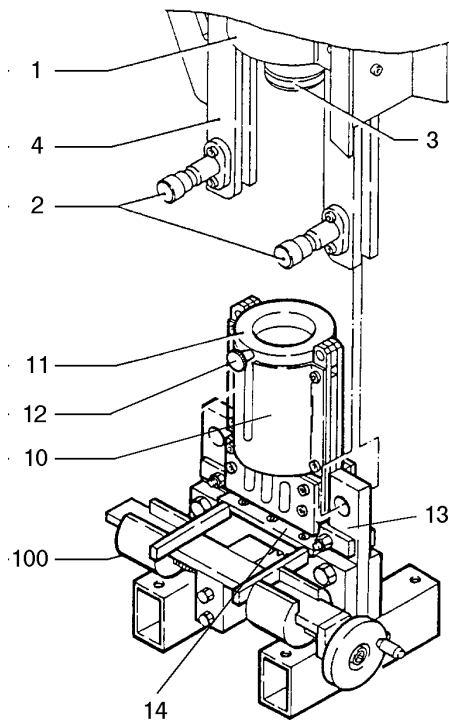

### Cutting:

1. Lift the protective device (10).
2. Place the rail into the cutting tool and align.

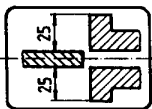

**Note:**

The distance between the outer edge of the cutting strip (14) and that of the cutting edge (15) is 25 mm.

3. Release the protective device (10).
4. Press the foot switch on the hydraulic unit and keep pressed until cutting is completed.

### ATTENTION !

BEFORE ATTACHING AND REMOVING THE SYSTEM TOOLS OR CARRYING OUT MAINTENANCE WORK, UNCOUPLE THE HYDRAULIC UNIT OR DISCONNECT IT FROM THE MAINS!

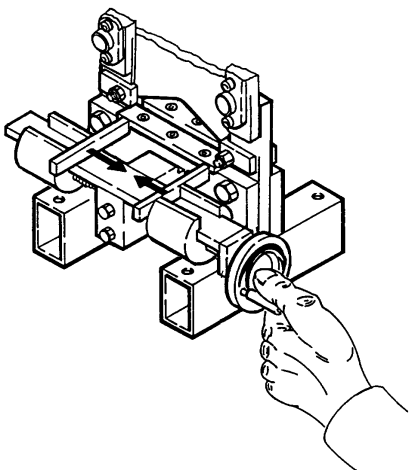

### Accessories

#### Vice (100), Order No. 6950

The vice is fastened to the cutting tool with 2 screws.

It is used for holding and aligning the rail at right angles to the cutting edge.

## Maintenance

### ATTENTION !

BEFORE ATTACHING AND REMOVING THE SYSTEM TOOLS OR CARRYING OUT MAINTENANCE WORK, UNCOUPLE THE HYDRAULIC UNIT OR DISCONNECT IT FROM THE MAINS !

After every 10 cutting operations: Remove any shreds, chips etc. from the cutting edge (6) and cutting strips (4).

Every week: Clean complete cutting tool.

Any worn or damaged cutting edges or strips must be replaced immediately.

### Changing the cutting edge

1. Pull the cutting edge (6) together with the base plate (7) and the protection device (8) out of the stand (1) (see fig. 2).
2. Unscrew the screws (8.9) from the protective device (8) and remove items 8.2 and 8.3.
3. Pull the base plate out of the protection device (8) together with the cutting edge.
4. Knock out the clamping sleeve (12) with a mandrel with a diameter of 5 mm.
5. Change the cutting edge.
6. Assemble the base plate and the new cutting edge.
7. Slip the protective device (8) over the base plate (7) and onto the cutting edge (6).
8. Use the screws (8.9) to attach items 8.2 and 8.3 to the protective device.

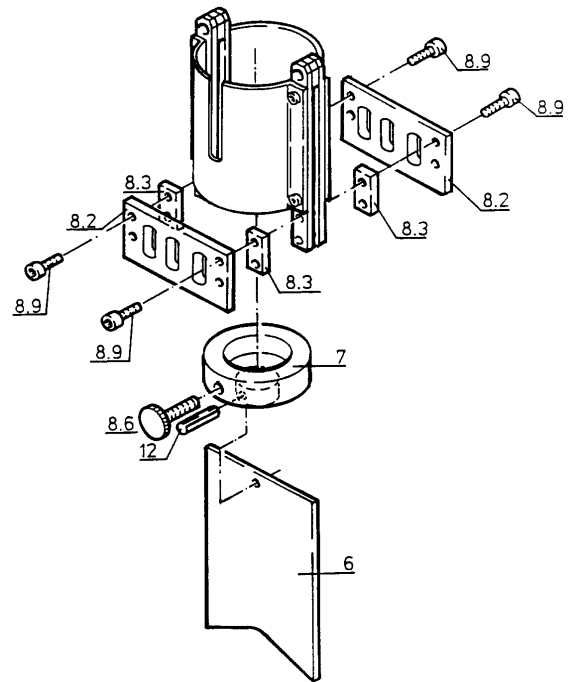

### Changing the cutting strips

1. Dismantle the cutting edge (14) guides.
2. Unscrew the bolts (10); change the cutting strips (4).

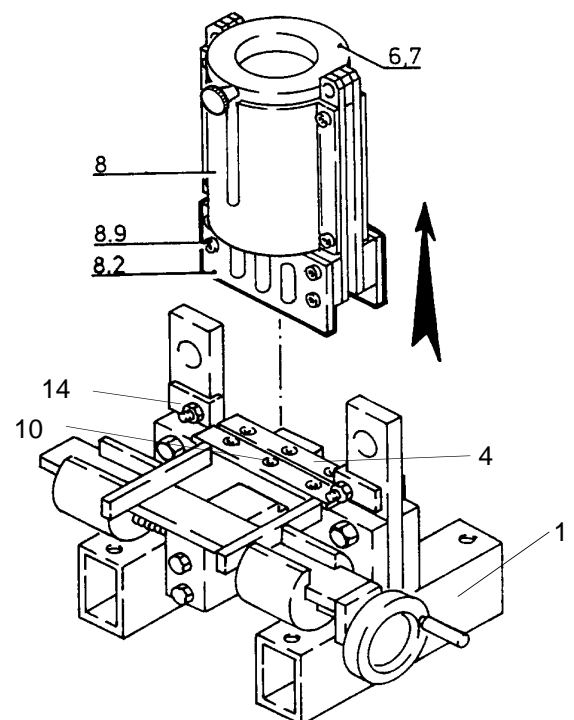

## HSBL - 160 Cutting Tool, Order No. 7020

### Operative range

You can cut the following with this tool:

- copper and aluminium rails of up to 160 x 12 mm (6" x 1/2") with a strength of max. 250 N/mm<sup>2</sup> (36 250 psi).
- steel rails of up to 160 x 6 mm (6" x 1/4 ") with a strength of max. 370 N/mm<sup>2</sup> (53 650 psi).

Waste consists of a piece the width of the cutting edge.

### Technical specifications:

Width:	without vice	255	mm (10")
	with vice	375	mm (14.8")
Depth:	without length stop	310	mm (12.2")
	with length stop	1440	mm (56.7")
Height	with working cylinder	940	mm (37")
Weight	without vice		
	and length stop	21.5	kg (47.3 lb)
	vice	3,0	kg (6.6 lb)
	length stop	6.0	kg (13.2 lb)

### Operation

There are four holes in the bases of the HSBL cutting tool 160. Use these holes to fasten the tool to a work bench.

The working cylinder (1), Order No. 2420, should be attached to the cutting tool (10) as follows:

1. Pull out the fixing bolts (2) on the working cylinder (1) as far as possible.
2. Slide the working cylinder (1) with the spars (4) onto the cutting tool (10). Align the holes on the cutting tool (10) with the fixing bolts (2) at the working cylinder (1).
3. Slide the fixing bolts (2) in as far as possible.
4. Slide the base plate (11) onto the piston rod (5) of the working cylinder (1). The tip of the holding screw (12) must be able to fit into the groove on the piston rod (5).
5. Tighten the holding screw (12).
6. Connect the working cylinder (1) and the HA hydraulic unit using the rapid-action coupling and the plug (see page 2). To deaerate the cylinder, carry out a few idle strokes. The hydraulic unit should be on a higher level than the working cylinder when deaerating.

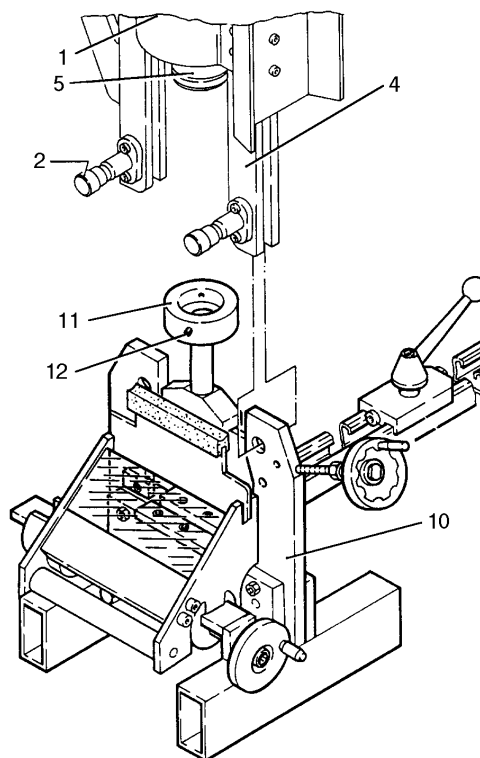

**Cutting:**

1. Place the rail into the cutting tool and align.
2. Press the foot switch on the hydraulic unit and keep pressed until cutting is completed.

**Return Stroke Limitation:**

The return stroke can be adjusted continuously.

Before setting the return stroke, the cutting edge must have been lowered.

- 1.1 Lower the cutting edge and keep the foot switch depressed.
- 1.2 Turn in the handwheel (14) of the return stroke screw (15) against the stop in the direction of the arrow.
- 1.3 Release the foot switch.
- 1.4 Turn out the handwheel (14) until the cutting edge is in the desired position.

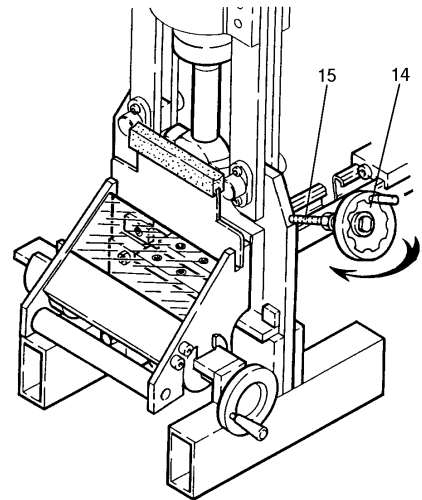
**Attention!**

The cutting edge must not be forced down with the return stroke screw (15).

**ATTENTION !** BEFORE ATTACHING AND REMOVING THE SYSTEM TOOLS OR CARRYING OUT MAINTENANCE WORK, UNCOUPLE THE HYDRAULIC UNIT OR DISCONNECT IT FROM THE MAINS!

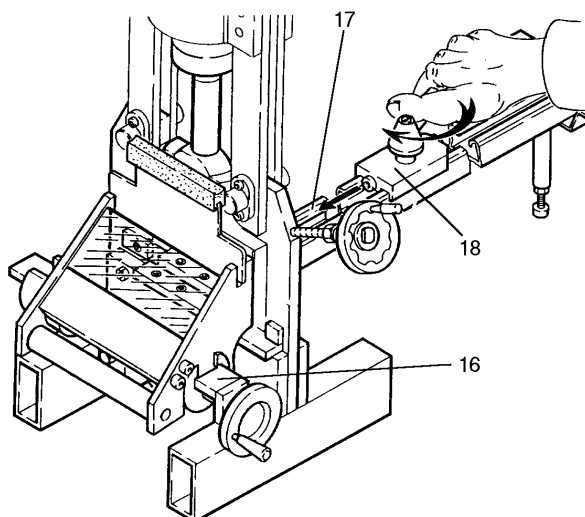
**Accessories:****1). Vice (16), Order No. 7030**

Description on page 5

**2). Length stop (17), Order No. 6990**

The length stop (17) is fastened to the cutting tool by two screws.

Any sizes between 20 and 1600 mm can be set with the slide (18).

**Maintenance**

<b>ATTENTION !</b> BEFORE ATTACHING AND REMOVING THE SYSTEM TOOLS OR CARRYING OUT MAINTENANCE WORK, UNCOUPLE THE HYDRAULIC UNIT OR DISCONNECT IT FROM THE MAINS !
---

After every 10 cutting operations: Remove any shreds, chips etc. from the cutting edge (2) and cutting strips (3).

Every week: Clean complete cutting tool.

Any worn or damaged cutting edges or strips must be replaced immediately.

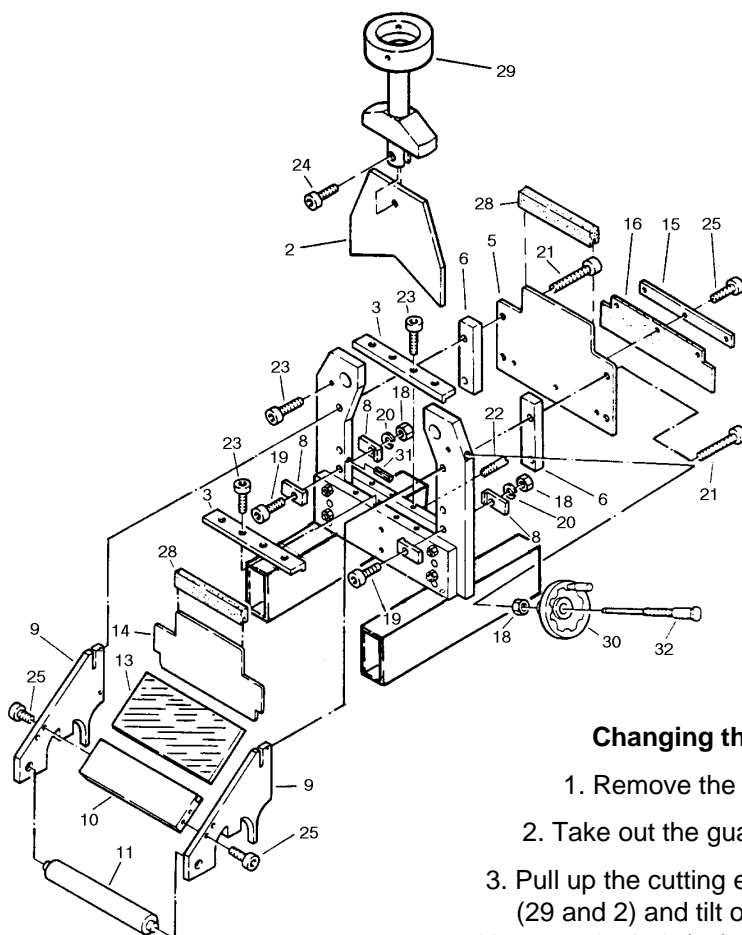

### Changing the cutting edges

1. Remove the working cylinder.
2. Take out the guard plate (14).
3. Pull up the cutting edge holder with the edge (29 and 2) and tilt out.
4. Unscrew the bolt (24) and change the edge (2).

### Changing the cutting rails

1. Unscrew the four bolts (21)
2. Remove parts Nos. 5 and 6 also the complete protective device.
3. Remove the cutting edge guides (8).
4. Unscrew the bolts (23) and change the cutting strips (3).

### Changing the protective window

1. Unscrew the No. 21 bolts.
2. Remove Nos. 5 and 6 and the complete protective device.
3. Pull the guard plates (14) out of the protective device.
4. Loosen the No. 25 bolts on one side.
5. Change the window.





## **HSBL - Plying Iron and Angle Indicator, Order No. 1179**

### **Operative range**

This plying iron can bend:

copper and aluminium conductor rails of up to 120 x 10 mm (4 3/4" x 3/8") with a strength of up to 250 N/mm<sup>2</sup> (36 250 psi). The maximum bending angle is 100° (degrees).

### **Technical specifications:**

Width	210	mm (8.3")
Depth	200	mm (7.8")
Working cylinder length	625	mm (24.6")
Weight	4.4	kg (9.7 lb)

Smallest flange length (inside size) at a rail thickness of 10 mm (3/8):

At a 90° angle	40	mm (1.6")
At U, flange height	80	mm (3.1")
At Z at 90° flange height	80	mm (3.1")

### **Operation**

1. Connect the HSBL cylinder (1) to the hydraulic unit using the rapid-action coupling and the plug (see page 2).
2. Carry out a few idle strokes to deaerate it. The hydraulic unit should be on a higher level than the working cylinder when deaerating.

### **Installing the tool**

1. Place the HSBL cylinder (1) on the stand (5). Put the U-shaped bottom tool (11) on to the piston rod (3) and screw in the 2 holding screws (12) by hand.
2. Place the angle indicator (13) with the fitting piece between the two cylinder spars (4) and slide in as far as possible.
3. Slide the top tool (14) between the cylinder spars (4) so that the chosen bending radius – 8 or 16 mm – faces towards the bottom tool.
4. Fasten the top tool (14) with the fixing bolts (11).
5. Push the angle indicator (13) back onto the top tool (14) as far as possible and tighten with the screw (3.3).

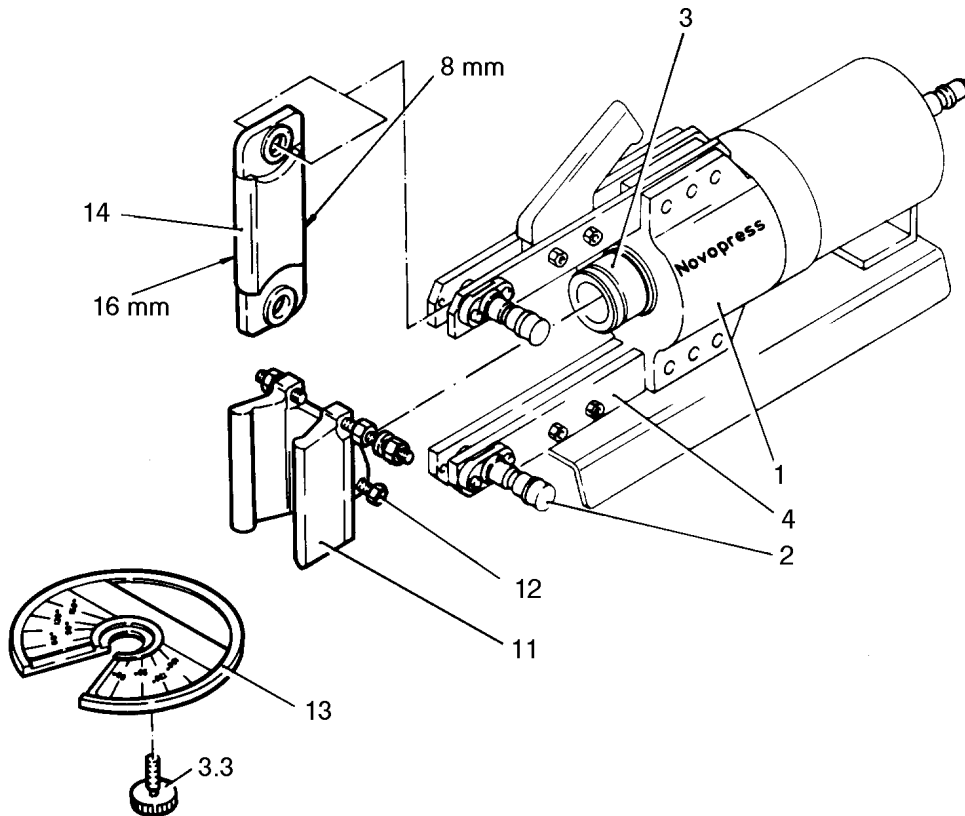

## 6. Aligning the bottom tool

### A) At right angles to the angle indicator

Align the U-shaped bottom tool (11) at right angles to the angle indicator (13) with the help of a back square (20).

Screw the threaded pins (15 and 17) onto the cylinder spars (4) so that they slide along the whole length of the cylinder spars (4) without any play. To test this, let the piston (3) run its whole length backwards and forwards.

Counter the threaded pins (15 and 17) with the nut (16).

Tighten the screws (12).

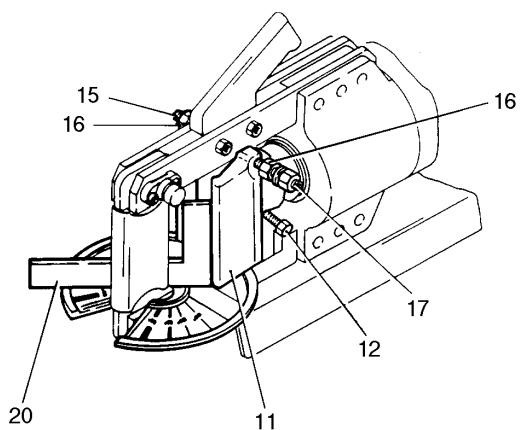

B) By running the machine with a piece of conductor rail, sized 120 x 10 ( $4\frac{3}{4}$ " x  $\frac{3}{8}$ " ), placed in it.

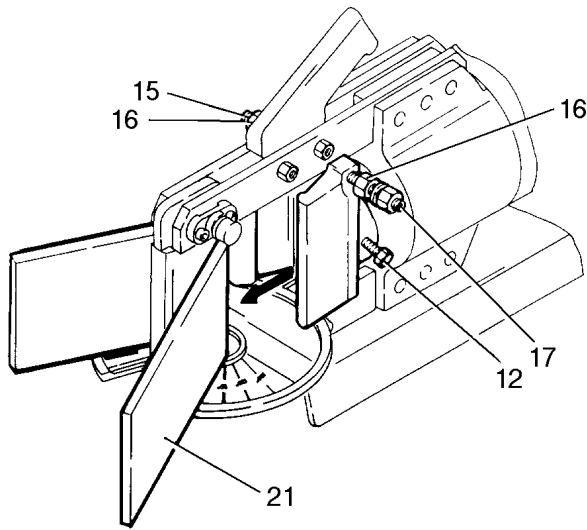

1. Turn back the nuts (16) on the threaded pins (15 and 17) by about 3 revolutions.
2. Unscrew the threaded pins (15 and 17) so that there is at least 2 mm of play between the cylinder spars (4) and the threaded pins.
3. Place a piece of conductor rail (21), e.g. 120 x 10 – 200 ( $4\frac{3}{4}$ " x  $\frac{3}{8}$ " – 8") into the plying iron.
4. Bend until the safety valve in the basic unit shuts the machine off. Keep the foot switch pressed down and tighten the screws (12). Now switch off and let the piston (3) return.
5. Tighten the threaded pins (15 and 17) so that they slide along the whole length of the cylinder spars (4) without any play. To test this let the piston (3) run its whole length forwards and backwards.

Then counter the threaded pins (15 and 17) with the nuts (16).

#### Bending without the hydraulic stop

1. Place the conductor rail on the angle indicator and hold straight.
2. Activate the foot switch and keep pressed until the required angle has been reached.
 

Red scale	for 8 mm ( $\frac{5}{16}$ " ) radius
Black scale	for 16 mm ( $\frac{5}{8}$ " ) radius
3. Release the foot switch and let the piston return.
4. Check the angle on the angle indicator.

If the angle is not sufficient then bend further by tapping the switch lightly.

#### Note:

*The top tool can be tilted out by removing one of the fixing bolts on the cylinder spar. This makes removing long pieces of rail easier.*

**ATTENTION !** BEFORE ATTACHING AND REMOVING THE SYSTEM TOOLS OR CARRYING OUT MAINTENANCE WORK, UNCOUPLE THE HYDRAULIC UNIT OR DISCONNECT IT FROM THE MAINS!

## Accessories

### HAV-2 Hydraulic Stop, Order No. 1627

#### Operative range

A hydraulic stop (HAV-2) can be supplied as an accessory to the HSBL plying iron. The HAV-2 hydraulic stop limits the forward and backward movements of the HSBL cylinder. The HAV-2 is of great use in mass production. Once the angle has been set, it can be used over and over again.

#### Mounting the hydraulic stop

1. The cylinder must be upright with the coupling plug facing upwards. Screw the coupling plug out of the HSBL cylinder (2) (see page 1).
2. Fix the valve's body (20) to the cylinder with the banjo bolt (21).
3. Screw the coupling plug (22) into the valve's body (20).
4. Remove a nut (16) from the threaded pin (17) (of the bottom tool). Place the fastening square (24) onto the threaded pin (17) and replace the nut (16) and tighten.
5. Loosen the banjo bolt (21) a little. Then align the valve's body (20) so that the holes for the sliding selector rod (25) in the fastening square (24) are in a line with those of the valve's body (20). Then tighten the banjo bolt (21) again.

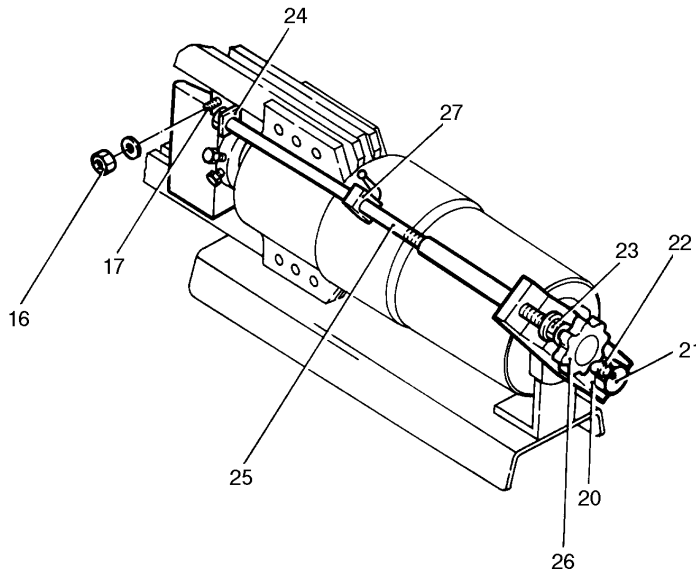

#### Setting the forward movement limit

1. Place the conductor rail on the angle indicator and hold straight.
2. Screw the adjusting nut (23) to a distance of approximately 20 mm ( $\frac{3}{4}$ " ) from the shut-off valve. Press the foot switch and keep pressed until the HAV-2 shuts off.
3. Turn the adjusting nut (23) back a little and then activate the foot switch again. Keep pressed until the HAV-2 shuts off. Then measure the angle on the bent rail. Repeat this procedure until the required angle has been achieved. After this, counter the adjusting nut (23) with the star grip. (26)

#### Setting the backward movement limit

The backward movement is set by moving and tightening the control cam (27).

The movement should be set so that it is easy to remove the angled piece of material.

**Maintenance****ATTENTION !**

UNCOUPLE THE HYDRAULIC UNIT OR DISCONNECT IT FROM THE MAINS BEFORE CARRYING OUT MAINTENANCE WORK.

After each use: Remove any dirt, chips etc. from the HSBL plying iron and the HA2-V.

Every week: Clean HSBL plying iron.

**HA2-V**

After every 3 months: Grease thread of the HA2-V.

## HSBL - 120 Punch, Order No. 1118

### Operative range

Holes can be punched into the following with this puncher:

- copper and aluminium rails of up to 120 x 13 mm (4<sup>3</sup>/<sub>4</sub>" x 1/2") with a strength of up to 250 N/mm<sup>2</sup> (36 250 psi). The largest hole diameter is 18 mm (at a 10 mm rail thickness 21 mm).
- steel rails of up to 120 x 6 mm (4 <sup>3</sup>/<sub>4</sub>" x 1/4") with a strength of up to 370 N/mm<sup>2</sup> (53 650 psi). The largest hole size is 21 mm diameter.

The punch can be operated with all NOVOPRESS hydraulic units (except with the HA 2). We recommend that the HA 1 hydraulic unit equipped with an electric motor be used.

### Technical specifications

Width	260	mm	(10.2")
Depth:	200	mm	(7.8")
Working cylinder height:	860	mm	(33.8")
Weight:	15	kg	(33 lb)
Clear width of the stand:	200	mm	(7.8")

### Operation:

There are four holes in the bases of the HSBL punching tool 120. Use these holes to fasten the tool to a work bench.

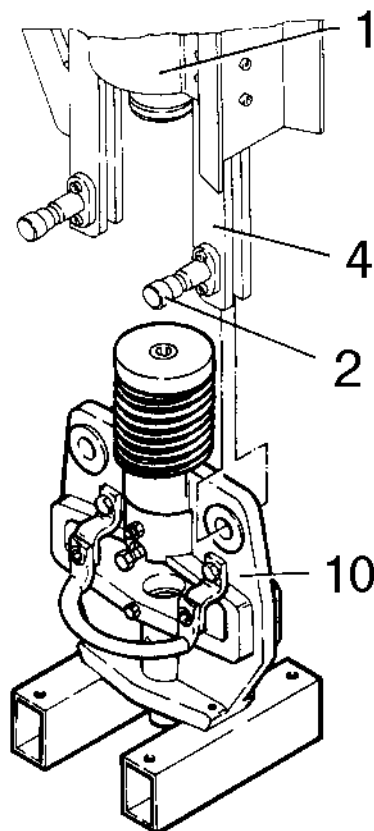

Slide the working cylinder (1), Order No. 2420, with the cylinder spars (4) onto the punch's press plate (10) and fasten with the fixing bolts (2). Connect the cylinder to the hydraulic unit using the rapid-action coupling and the plug (see page 2).

To deaerate carry out a few idle runs. The hydraulic unit should be on a higher level than the working cylinder when deaerating.

### **ATTENTION !**

BEFORE ATTACHING AND REMOVING THE SYSTEM TOOLS OR CARRYING OUT MAINTENANCE WORK, UNCOUPLE THE HYDRAULIC UNIT OR DISCONNECT IT FROM THE MAINS!

### Application rules for tools

- **The diameter of the hole to be punched must not be less than the thickness of the material.** If this rule is not followed, the tool will be damaged.
- **It is not permitted** to increase the size of a hole by **consequential punching**, since this results in damage of the tool. Furthermore, the **minimum distance** from one hole to the next and the distance from a hole to the edge of the bar must be **at least the diameter** of the tool.
- **Exchange the tools at due time.** Excessive wear of the tool might result in the upper tool getting stuck in the rail. Separation of the tools from the rail by excessive force can lead to tools damage.
- When not in use, **clean and oil the tools.** The tools' life is increased if they are lightly oiled from time to time.

Tool storage: Do **not** place the upper tool into the lower tool. The cutting edges can be damaged.

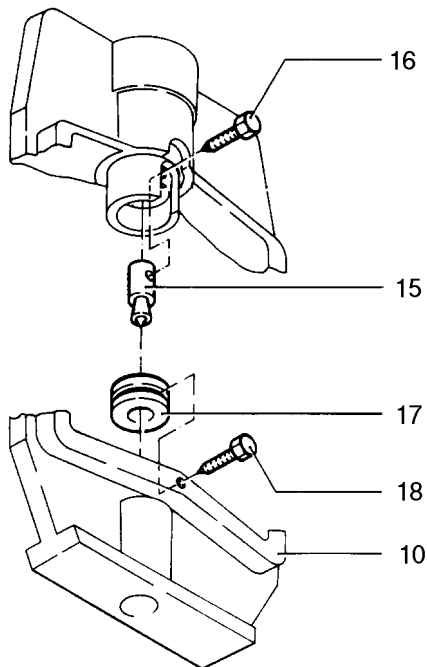

### Top tool

1. Place the top tool (15) with the shaft into the hole in the column. The counter-sunk hole in the tool's shaft should be facing the locking screw (16).
2. Screw in the locking screw (16) by hand and test whether the point of the locking screw (16) is in the counter-sunk hole of the shaft by turning the top tool (15).
3. Tighten the locking screw (16).

The top tool has a fixed back center and cannot be reground.

### Bottom tool

1. Mounting

#### Note:

*The receptacle for the lower tool must be free from dirt, chips etc.*

Place the bottom tool (17) into the hole on the press plate (10) and fasten with the locking screw (18).

2. Dismantling
  - a) Unscrew the screw (18) from the bottom tool
  - b) Push out the bottom tool (17) with the ejector

The bottom tool can be reground by approximately 2 mm.

**Warning:** When mounting tools with a profile, the top (15) and bottom tools (17) are not to be staggered.

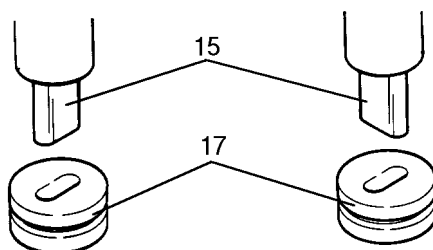



### Punching without a template

1. Place the center-marked rail in the punch's working area.
2. Lift the rail and align the center mark with the back center of the top tool and hold.
3. Straighten the rail so that it is parallel to the bottom tool's surface. Activate the foot switch on the hydraulic unit (punching).
4. Release the foot switch immediately after the hole has been punched. This will prevent an unnecessary heating of the hydraulic oil.

### Holding down appliance-stripper

The punch is equipped with a holding down appliance. The holding down appliance pad also functions as a stripper when flat bars of over 40 mm (15/8") width are being worked.

For flat bars with a width of less than 40 mm (15/8") and for lamellar copper, we offer auxiliary strippers in addition to round tools.

Each upper tool has an auxiliary stripper of its own in a diameter range from 5 to 7,9 mm. In a diameter range of 8 to 14 mm, ( $\frac{5}{16}$ " to  $\frac{9}{16}$ ") one auxiliary stripper is sufficient for all upper tools.

Auxiliary stripper Order No.	Upper tool „D“ Order No.	Upper tool + stripper Order No.
8478	5,0 mm 21990018	8481
8479	6,0 mm 21990019	8482
8399	6,6 mm 21990013	7861
8401	9,0 mm 21990014	7862
	11,0 mm 21990015	7665
	12,5 mm 21990016	7863
	14,0 mm 21990017	7864

**ATTENTION !** When subsequently ordering upper tools, it is absolutely necessary to state that the upper tool is used in conjunction with the auxiliary stripper. Intermediate sizes, e.g. D 5.2 mm, ( $\frac{3}{16}$ ") on request.

### Long upper tool (bare)

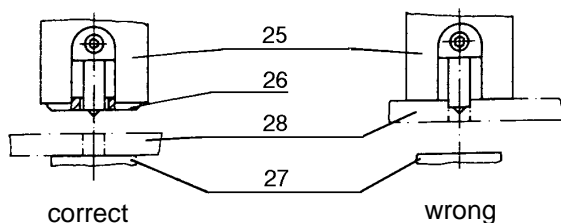

Key:

- 25 = holding down appliance
- 26 = auxiliary stripper
- 27 = cutting plate
- 28 = position of the workpiece after stripping

The metallically bare upper tools may only be used in conjunction with the auxiliary strippers (26).

These upper tools are longer than the black standard upper tools. When using the bare upper tools – without auxiliary strippers – the workpiece will stick to the upper tool - will not be stripped off **R I S K OF DIE BREAKAGE**

Prior to punching, it is absolutely necessary to strip the material. The material thickness without insulation may amount to max. 10 mm.

**Standard upper tool (black)**

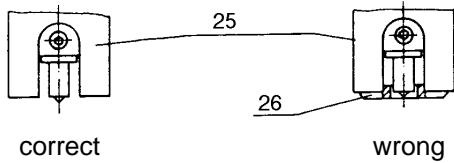

The black standard upper tools must not be used in conjunction with the auxiliary strippers, because:

- the center is not visible
- the collar of the upper tool may collide with the auxiliary stripper.<sup>7</sup>

**Assembly**

Place the auxiliary stripper (26) in the holding down appliance (25) and push it firmly into position manually (beware of the center)

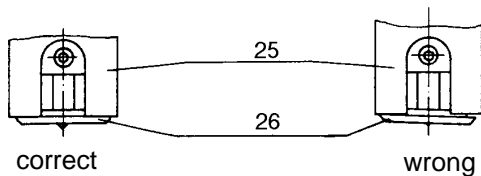
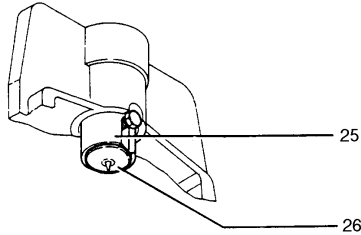

The auxiliary stripper (26) must be in plane contact with the lower side of the holding down appliance (25).

**Disassembly**

Pull the auxiliary stripper (26) out of the holding down appliance (25).

**Accessories**

**Punching with a template**

No marking - no center-marking.

Templates for punching with the HSBL punch are available. These are attached to a holder (Order No. 4109) that can be screwed onto the punch.

The width of the rails ("b") and the hole arrangement are listed in the table below. The holes are arranged according to DIN 43 673.

Order No. of LS Template	b - mm	Hole arrangement	b - mm	Hole arrangement	Sizes in mm		
					e1	e2	e3
4026	40		80		20	40	40
4068	50		100		20	40	50
4070	60		120		20	40	60

Special templates on inquiry.

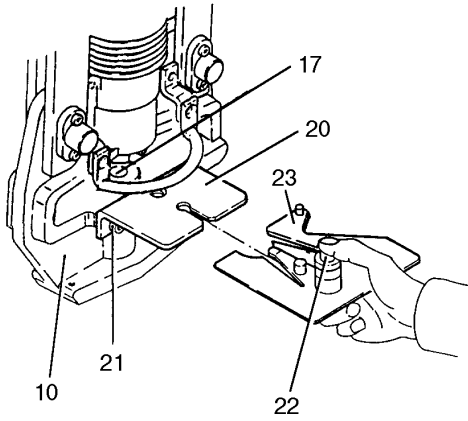

### Mounting

1. Attach the holder (20), Order No. 4109, with two cap screws (M10 x 16) (21) to the press plate (10) in such a way that the top edges of the holder (20) and press plate (10) are level.
2. While pressing down the catch button (22), slide the template (23) into the holder (20) until it reaches the bottom tooling (17) and let it snap into place.
3. Let go of the catch button (22).

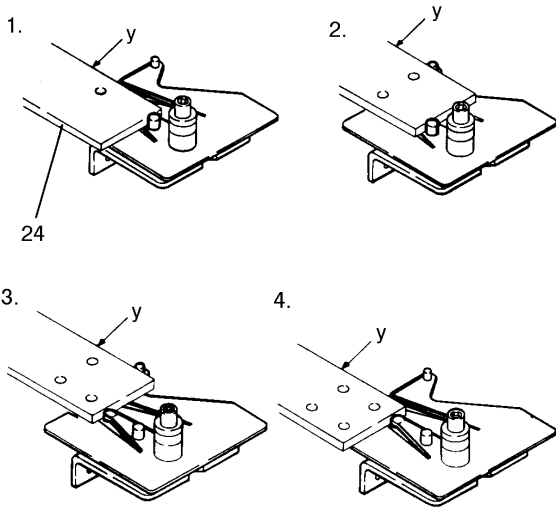

### Dismantling

1. Press down the catch button (22).
2. Slide out the template (23).

The width of the rails and hole arrangement are stated on every template. The rail (24) is to be centered in the template as shown in pictures 1 to 4.

To get a certain hole arrangement the rail must always be centered with the same "Y" side on the template.

### Maintenance

#### ATTENTION !

UNCOUPLE THE HYDRAULIC UNIT OR DISCONNECT IT FROM THE MAINS BEFORE CARRYING OUT MAINTENANCE WORK.

### Punch

Before each tool installation:

Clean the hole for the lower tool. The receptacle must be free from dirt, shreds etc.

If dirty:

- Clean the seat for the rails.
- Clean the templates.

Every week:

- Clean and grease the HSBL punch.

### Tools

See application rules.

## **HSBL 160 Punch, Order No. 7050**

### **Operative range**

The following can be punched with this punching tool:

- copper and aluminium rails of up to 160 x 13 mm ( $6\frac{3}{8}$ " x  $\frac{1}{2}$ " ) with a strength of up to 250 N/mm<sup>2</sup> (36 250 psi). The largest hole diameter is 18 mm (at a 10 mm rail thickness 21 mm).
- steel rails of up to 160 x 6 mm, with a strength of up to 370 N/mm<sup>2</sup> (53 650 psi).  
The maximum hole diameter is 21 mm.

The punch can be used with all NOVOPRESS hydraulic units, except with the HA2. We recommend that the HA 1 with an electric motor be used.

### **Technical specifications**

Width:	without stop device	440 mm (17.3")
	with stop device	600 mm (23.6")
Depth:	without stop device	300 mm (11.8")
	with stop device	460 mm (18")
Height of the working cylinder:		900 mm (35.4")
Weight:	without stop device	27.8 kg (61.2 lb)
	with stop device	38.2 kg (84 lb)

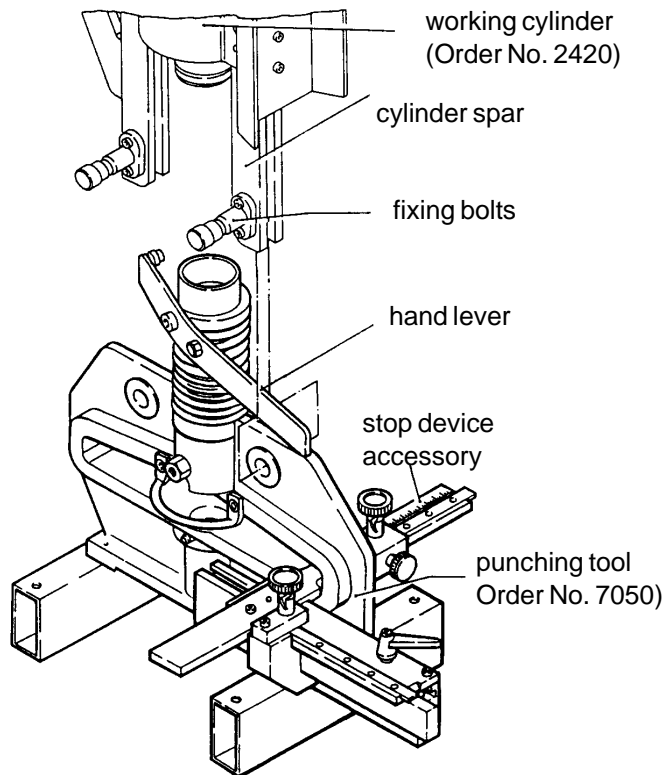

### **Operation**

There are four holes in the bases of the HSBL punching tool 120. Use these holes to fasten the tool to a work bench.

Slide the 2420 working cylinder with the cylinder spars on to the punch's pressure plate and fasten with the fixing bolts. Connect the working cylinder to the hydraulic unit using the rapid-action coupling and the plug (see page 2).

To deaerate the cylinder carry out a few idle runs.

The hydraulic unit should be on a higher level than the working cylinder when deaerating.

### **Application rules for tools**

see HSBL-120 Punch

#### **Top tool**

see HSBL-120 Punch

#### **Bottom tool**

see HSBL-120 Punch

### **Punching**

#### **1. WITHOUT STOP DEVICE.**

- 1.1 Place the center-marked conductor rail in the working area of the punching tool.
- 1.2 Pull down the top tool with the hand lever and align the center mark with the punching tool's back-center.
- 1.3 Press the HA 1 hydraulic unit's foot switch. Keep pressed until the punching process has been completed.

## 2. WITH STOP DEVICE

- 2.1 Slide the rail in onto the stop device and hold it there until punching is completed. Setting the stop device (see section "STOP DEVICE")

**ATTENTION !** BEFORE ATTACHING AND REMOVING THE SYSTEM TOOLS OR CARRYING OUT MAINTENANCE WORK, UNCOUPLE THE HYDRAULIC UNIT OR DISCONNECT IT FROM THE MAINS!

### Accessories

#### Punching with a template

#### Stop device, Order No. 7190

The stop device can be adjusted by 150 mm in the X and Y axes.

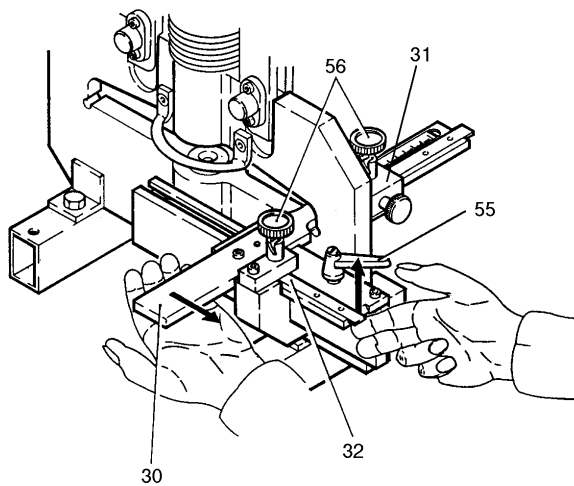

The distance between the holes can be set by using the scale or by using the fixed distances on the templates. The arrangement of the holes in the completed template conforms to DIN 43673. The respective width of the intended bar is inscribed on the template.

#### 1. Setting the stop device with the scale

- 1.1 Turn the thumb screws (56) anti-clockwise as far as they will go.
- 1.2 X-axis. Loosen the locking lever (55). Set the stop rail (30) and tighten.
- 1.3 Y-axis. Loosen the thumb screw (57). Set the slide (31) and tighten.

#### 2. Setting the stop device with a template

- 2.1 X-axis. Loosen the locking lever (55). Turn the thumb screw (56) clockwise as far as it will go and hold. Set the stop rail (30) so that the stop bolt is positioned between the holes on the template (32). Release the thumb screw (56) and slide the stop rail (30) until the stop bolt clicks into the next hole on the template.
- 2.2 Y-axis. Loosen the thumb screw (57). Turn the thumb screw (56) clockwise as far as it will go and hold. Set the slide (31) so that it is positioned between the holes on the template (32). Release the thumb screw (56). Continue moving the slide (31) until it clicks into place in the next hole.

### Changing the templates

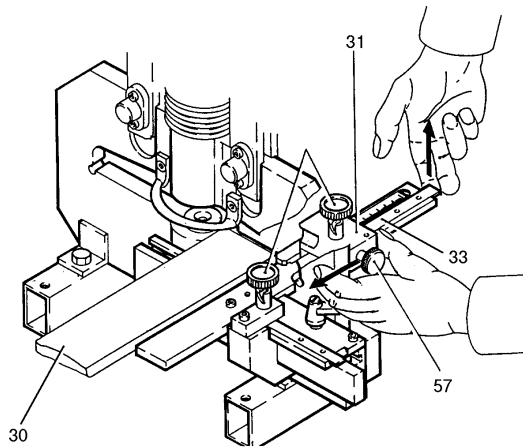

1. The templates are flat irons with holes for the corresponding hole arrangement.
2. Move the slide (31) or the stop rail (30) until it comes to rest against the stop.
3. Lift the template (33, 34) and pull out.
4. Take care, when inserting the template, that the centering bolt clicks into the last hole on the template

### Mounting the stop device

1. Move the slide (31) off the stop rail (30).
2. Place the stop device onto the punch and fasten with the two supplied screws.
3. Move the slide (31) onto the stop rail (30).

### Maintenance

siehe HSBL-Lochwerkzeug 120

For the manufacture of templates which comply with your requirements, we will supply unmarked guiding plates.

Ref.-Nos.: Unmarked guiding plate for X-axis (60) is 7681

Unmarked guiding plate for the Y-axis (61) is 7682

The distance "e" for the boring (D=.216") are to be determined in accordance with the attached drawing.

For the measures  $e_1$ ,  $e_2$ , and  $e_3$ , please refer to the applicable standards.

$$\text{Measure } e_4 = \frac{\text{Bar width "B" - } e_3}{2}$$

EXAMPLE FOR TEMPLATE MANUFACTURE

$$\text{Bar width "B"} = 4"$$

#### For the X-axis

$$\begin{aligned} \text{The distance "X"} &= 196 + B - e_4 && 4" - 2" \\ &= 196 + 4" - 1" && e_4 = \frac{4" - 2"}{2} = 1 \\ X &= 3.196" \end{aligned}$$

After having determined the distance "X", mark the measures  $e_3$  on the guiding plate (62).

#### For the Y-axis

$$\begin{aligned} \text{The distance "Y"} &= 5.51" - e_1 \\ Y &= 5.51" - 1" \\ Y &= 4.51" \end{aligned}$$

After having determined the distance "Y", mark the measures  $e_2$  on the guiding plate (62).

Drawing: Bmax. 6"  
 Bmin. 1,25"  
 62 DIA.236"  
 – 001 tolerance  
 DIA.216"  
 61 DIA.216"  
 62 DIA.236"  
 X = (.196"+B-e4)  
 – .003 tolerance  
 60

ATTENTION: Holes in square configuration (s. drawing) as follows:

$$e_1 = e_4 \text{ and } e_2 = e_3$$

Service

**novopress**

Scharnhorststraße 1  
D-41460 Neuss

Postfach 101163  
D-41411 Neuss

Federal Republic of Germany  
Tel. 02131 / 288-0  
Telefax 02131 / 28855