

# Operating Instructions

## Parts List



### Hand Pallet Truck AC20SL and AC20SL-N

**Note: Operator MUST read and understand this operating instructions before use this Hand Pallet Truck.**

Thank you for using our pallet truck. Your pallet truck is made of high quality steel and is designed for the horizontal lifting and transport of loads on a pallet or standardized containers on a level, fixed base. For your safety and correct operation, please carefully read this instruction before using it.

**NOTE: All of the information reported herein is based on data available at the moment of printing. We reserves the right to modify our own products at any moment without notice and incurring in any sanction. So, it is suggested to always verify possible updates.**

## 1. GENERAL SPECIFICATIONS

Capacity	2000KG / 4400LBS		
Fork Height Raised	165MM / 6-3/4 in		
Fork Height Lowered	51MM / 2in		
Fork Length	1150MM / 45in or 1220MM / 48in		
Width Across Forks	520MM / 20 1/2in	685MM / 27in	838MM / 33in
Individual Fork Width	160MM / 6-5/16in		
Roller Size	Ø50X70MM / Ø1-31/32 x 2 3/4in (Steel)		
Mail Wheel Size	Ø180X50 / Ø7-1/4 x 2in		

Special fork length are available 800, 900, 950, 1000, 1500, 2000mm.

Materials and specification are subject to change without notice.

## 2. TO ATTACH DRAW-BAR TO PUMP UNIT

If you have purchased a wooden box of pallet truck, some assembly is required. Certainly, you need some tools, a hammer, a pliers, a spanner, etc; and some parts, one axle with hole (G105), two elastic pins (G106)(**Note one is in the axle (G105)**), these parts are putted in a plastic bag, which is putted into the draw-bar.

**NOTE: The number of draw-bar and pump should be the same.**

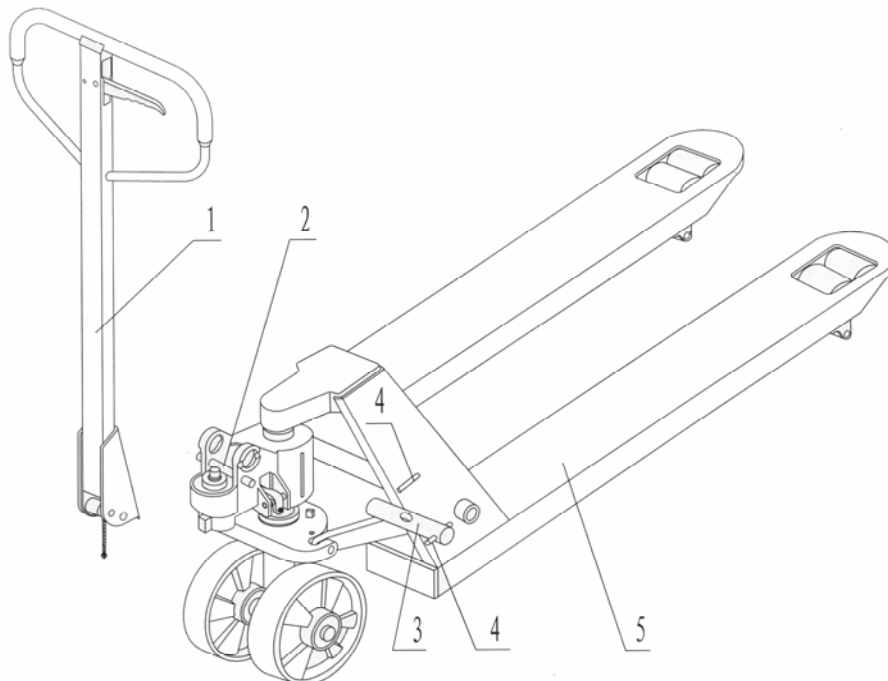

1. Draw-bar 2. Pin 3. Axle with hole 4. Elastic pin 5. Fork frame

Fig. 1

When attaching the handle, you had better squat just behind the pallet truck. Then you:

**2.1** Insert the draw-bar onto the pump piston (303), then use a hammer to insert the axle with hole (G105) into the hydraulic pump and draw-bar **from the right to left.** (See fig. 2 ).

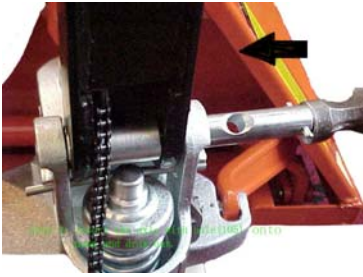

Fig. 2

2.2 Let control handle(G117) to the 'LOWER' position, then pass the adjusting nut(G104), adjusting bolt(G103) and chain(G102) through the hole of axle(G105) with your hand (See fig. 3).

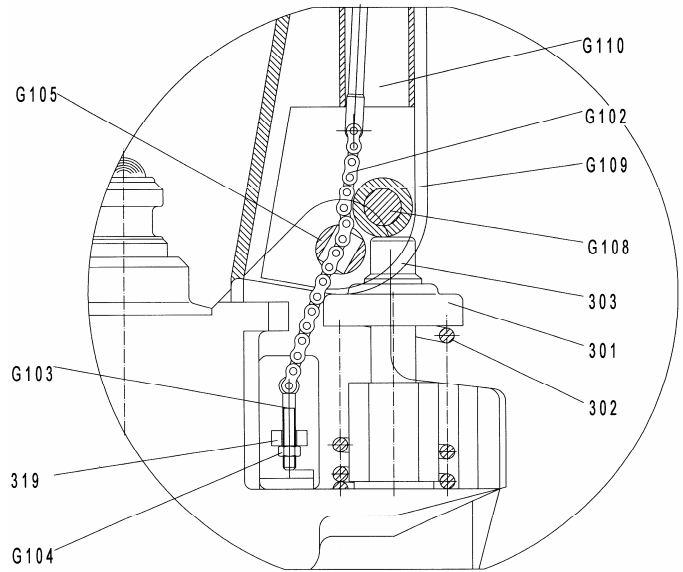

Fig. 3

2.3 Press the draw-bar (G110) down, take away the pin(#2) (See Fig. 1).

2.4 Let the control handle (G117) on 'RAISE' position, then raise the lever plate (319) with the pin (#2) and insert the adjusting bolt(G103) into the front slot of lever plate (319), note to keep the adjusting nut (G104) on the under side of the lever plate.

2.5 Use a hammer to tap another elastic pin (G106) into the axle with hole (G105).

The draw-bar is now assembled to the pump.

### 3. TO ADJUST RELEASE DEVICE

On the draw-bar of this pallet truck, you can find the control handle(G117) which can be regulated in three positions :

- Raise** -handle down
- Drive position** -handle in center position
- Lower** -handle up, the lever moves back the drive position when released.

If however they have been changed, you can adjust according to following step:

- 3.1 If the forks elevate while pumping in the **DRIVE** position, turn the adjusting nut (G104) on the adjusting bolt(G103) or screw(318) clockwise until pumping action does not raise the forks and the **DRIVE** position functions properly.
- 3.2 If the forks descend while pumping in the **DRIVE** position, turn the nut(G104) or screw(318) counter-clockwise until the forks do not lower.
- 3.3 If the forks do not descent when the control handle (G117) is in the **LOWER** position, turn the nut(G104) or screw (318) clockwise until raising the control handle(G117) lowers the forks. Then check the **DRIVE** position according to item 3.1 and 3.2 to be sure the nut (G104) and screw(318) is in the proper position.
- 3.4 If the forks do not elevate while pumping in the **RAISE** position, turn the nut (G104) or screw (318) counter-clockwise until the forks elevate while pumping in the **RAISE** position. Then check the **LOWER** and **DRIVE** position according to item 3.1, 3.2 and item 3.3.

### 4. MAINTENANCE

The pallet truck is largely maintenance-free.

#### 4.1 OIL

Please check the oil level every six months. The oil can be hydraulic oil: ISO VG32, its viscosity should be 30cSt at 40° C, total volume is about 0.4lt.

#### 4.2 TO BANISH THE AIR

The air may come into the hydraulic oil because of transportation or pump in upset position. It can cause that the forks do not elevate while pumping in the **RAISE** position. The air can be removed in

the following way: let the control handle (G117) on the **LOWER** position, then move the draw-bar up and down for several times.

### 4.3 DAILY CHECK AND MAINTENANCE

Daily check of the pallet truck can limit wear as much as possible. Special attention should be paid to the wheels, the axles, as thread, rags, etc. It may block the wheels. The forks should be unloaded and lowered in the lowest position when the job is over.

### 4.4 LUBRICATION

All bearings and shafts are provided with long-life grease at the factory. You only need provide with long-life grease at monthly intervals or after each time the truck is cleaned thoroughly to the lubrication points.

## 5 GUIDE TO SAFETY OPERATION

- 5.1 Operator should read all warning signs and instructions here and on the pallet truck before using this truck.
- 5.2 Do not use on a slopping ground.
- 5.3 Do not operate a pallet truck unless you are familiar with it and have been trained or authorized to do so.
- 5.4 Do not operate a pallet truck unless you have checked its condition. Give special attention to the wheels or rollers, the draw-bar unit, the fork unit, the lever plate, etc. .
- 5.5 To pull the truck, always move the control handle into the drive position. This makes the draw-bar easier to move and depressurizes the pump section of the hydraulics. This preserves the hydraulic seals and the valve components. A long service life can be expected.
- 5.6 Do not take up any people on the pallet truck.
- 5.7 The operator had better take on gloves for labor protecting.
- 5.8 When the goods have been transported, all people should be away from the forks for 600mm.
- 5.9 Do not load goods like fig. 5/B and load over maximum capacity.
- 5.10 At others special condition or place, the operator should be carefully to operate the pallet truck.

## 6. TROUBLES SHOOTING

No	Trouble	Clause	Fixing Methods
1	The forks can not be up the max. height.	The hydraulic oil is not enough.	-Pour in the oil.
2	The forks can not be lifted up.	-Without hydraulic oil. -The oil has impurities. -The nut (G104) is too high, keep the pumping valve open. -Air come into the hydraulic oil.	-Fill in the oil. -Change the oil. -Adjust the nut(G104) or screw (318) (see item 3.4) -Banish the air.(see item 4.2)
3	The forks can not be descended.	-The piston rod(328) or pump (322) is deformed resulting from partial loading slanting to one side or over-loading. -The fork was kept in the high position for long time with piston rod bared to arise in rusting and jamming of the rod. -The adjusting nut (G104) or screw (318) is not in correct position.	-Replace the piston rod (328) or pump (322). -Keeping the fork in the lowest position if not using, and pay more attention to lubricate the rod. -Adjust the nut (G104) or screw (318) (see item 3.3)
4	Leaks	-Sealing parts worn or damaged. -Some part cracked or worn into small.	-Replace with the new one. -Replace with the new one.
5	The fork descends without the release valve worked.	-The impurities in the oil cause the release valve to be unable to close tight. -Some parts of hydraulic system is cracked or bored. -Air come into the oil. -Sealing parts worn or damaged. -The adjusting nut (G104) or screw (318) is not in the correct position.	-Replace with new oil. -Inspect and replace the waste parts. -Banish the air. (See item 4.2) -Replace with the new one. -Adjusting the nut (G104) or screw (318). (See item 3.2)

**NOTE: DO NOT ATTEMPT TO REPAIR THE PALLET TRUCK UNLESS YOU ARE TRAINED AND AUTHORIZED TO DO SO.**

Fig. 4

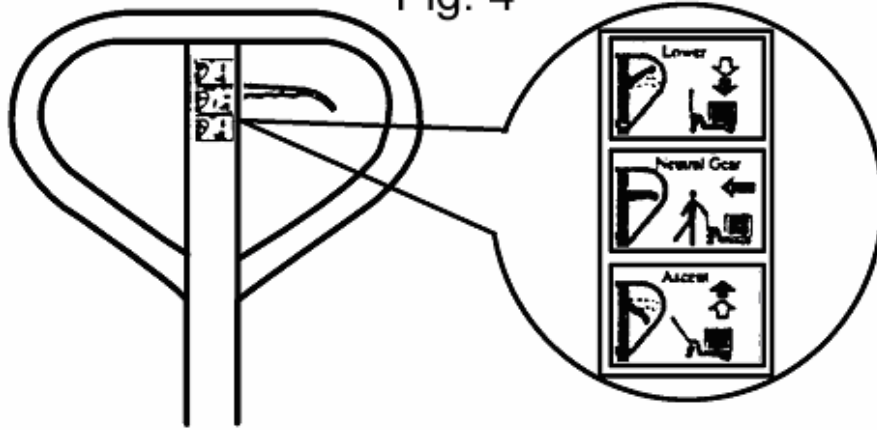
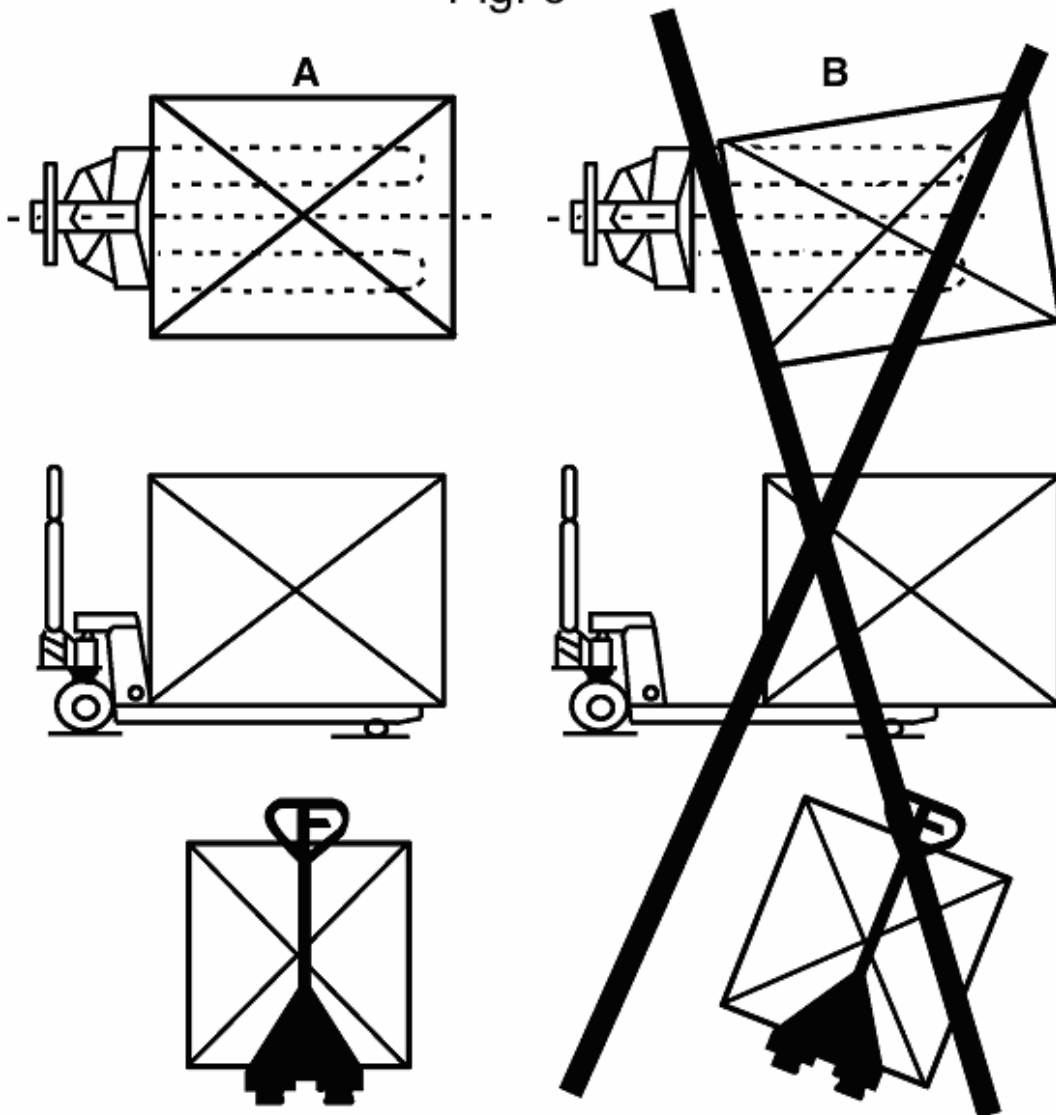
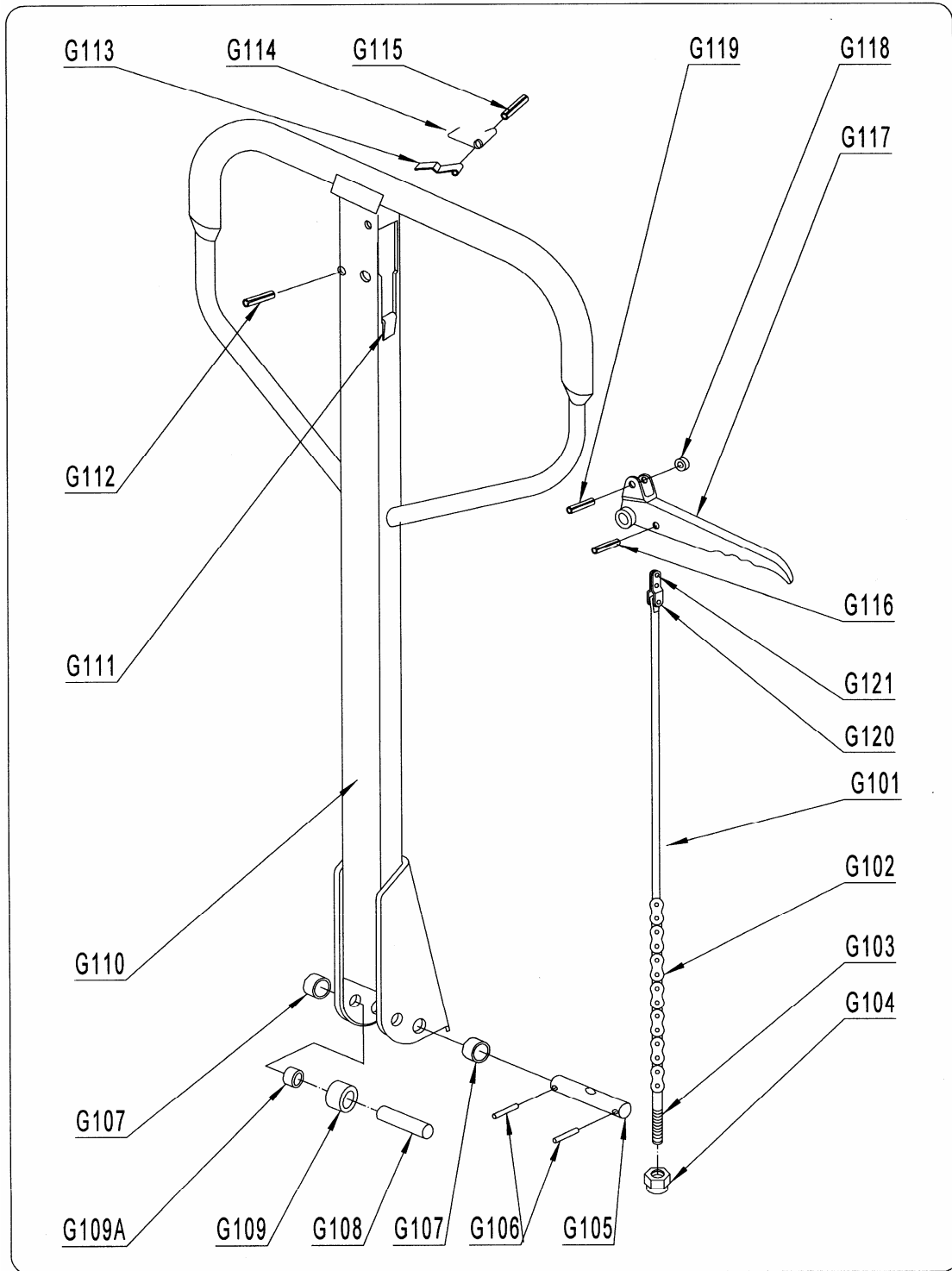

Fig. 5





No.	Description	Qty.	No.	Description	Qty.
G101	Release Rod	1	G111	Stop Rubber	1
G102	Chain	1	G112	Elastic Pin	1
G103	Adjusting Bolt	1	G113	Blade Spring	1
G104	Adjusting Nut	1	G114	Spring	1
G105	Axle with Hole	1	G115	Elastic Pin	1
G106	Elastic Pin	2	G116	Elastic Pin	1
G107	Bushing	2	G117	Control Handle	1
G108	Roller Pin	1	G118	Roller	1
G109	Pressure Roller	1	G119	Elastic Pin	1
G109A	Bushing	1	G120	Pin	1
G110	Draw-bar	1	G121	Pull Board	1

## Fork Frame Unit

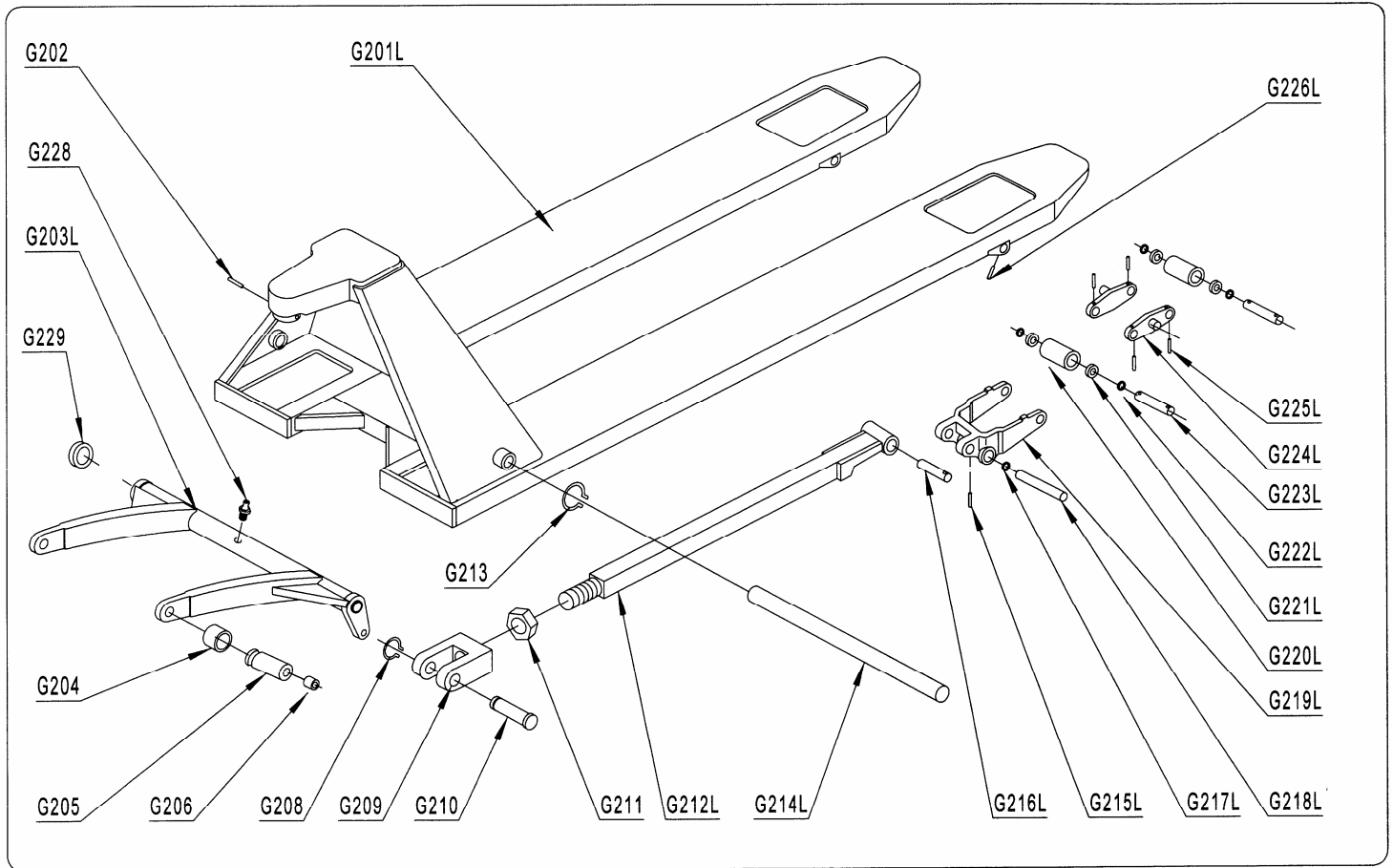

No.	Description	Qty.	No.	Description	Qty.
G201L	Fork Frame	1	G216L	Shaft	2
G202	Elastic Pin	1	G217L	Washer	4
G203L	Rock - Arm	1	G218L	Shaft	2
G204	Bushing	2	G219L	Frame of Roller	2
G205	Shaft	2	G220L	Roller	4
G206	Grease Cup	2	G221L	Bearing	8
			G222L	Washer	8
G208	Retaining Ring	2	G223L	Axle for Roller	4
G209	Joint	2	G224L	Linking Plate	4
G210	Pin	2	G225L	Elastic Pin	8
G211	Nut	2	G226L	Elastic Pin	2
G212L	Pushing Rod	2			
G213	Retaining Ring	2	G228	Grease Cup	1
G214L	Long Shaft	1	G229	Washer	2 / 1
G215L	Elastic Pin	2			

# Hydraulic Pump Unit

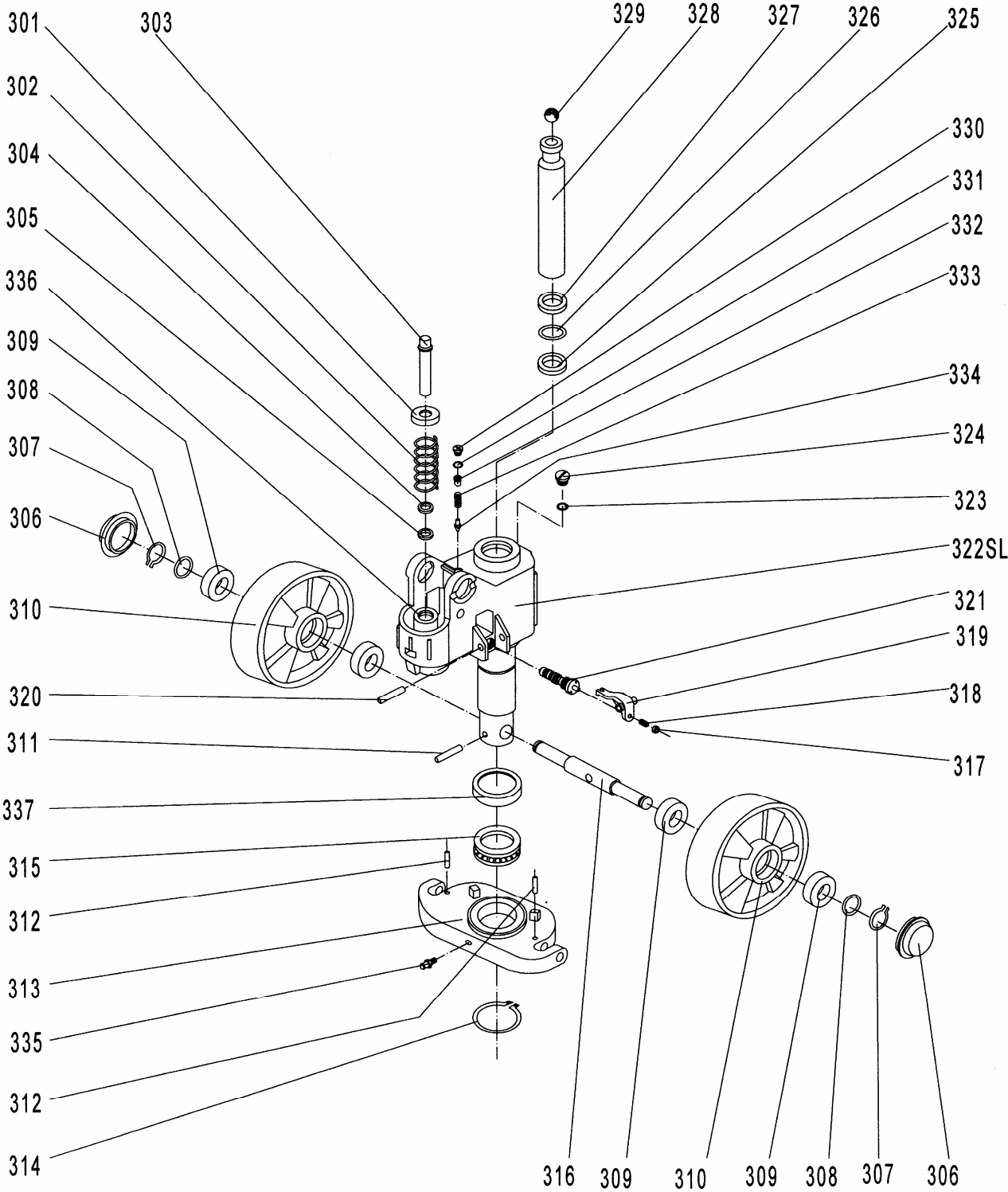



## Hydraulic Pump Unit

No.	Description	Quantity	Remark
301	Spring Cap	1	
302	Spring	1	
303	Pump Piston	1	
304	Dust Ring	1	
305	Seal	1	
306	Dust Cover	2	
307	Locking Ring	2	
308	Washer	2	
309	Bearing	4	
310	Loading Wheel	2	
311	Elastic Pin	1	
312	Elastic Pin	2	
313	Thrust Plate	1	
314	Retaining Ring	1	
315	Bearing	1	
316	Shaft of loading Wheel	1	
317	Nut	1	
318	Screw	1	
319	Lever Plate	1	
320	Elastic Pin	1	
321	Valve Cartridge	1	
322SL	Pump Body	1	For AC20SL Only
323	Seal Washer	1	
324	Screw Plug	1	
325	Seal	1	
326	O – Ring	1	
327	Dust Ring	1	
328	Piston Rod	1	
329	Steel Ball	1	
330	Screw Plug	1	
331	O - Ring	1	
332	Bolt	1	
333	Spring	1	
334	Spindle of Safety Valve	1	
335	Grease Cup	1	
336	Cylinder	1	
337	Cover of Bearing	1	