



## EW65

### Wheeled Excavator

power and speed

With a Wacker Neuson EW65 wheeled excavator, an operator can easily jump in the cab and head to the job site. The machine's road travel mode helps reduce time- and cost-intensive transport, while the variable drive system has a low rate of fuel consumption. With just one pedal to operate, the EW65 drives almost like a car. But it's a highly capable excavator, too. The powerful load-sensing hydraulic system (LUDV) ensures the same speed for several boom movements with different loads. With proportional control auxiliary hydraulics and a triple boom, the EW65 offers smooth work with attachments and an excellent digging range.

### Highlights

- 3-point kinematics
- Intuitive operating concept
- Optimal positioning of hydraulic components
- Powerful drive system with LUDV
- Triple boom

### Technical Data

#### Hydraulic

Operating pressure hydraulics	240.0 bar
Flow rate	144.0 l/min
Tank capacity	92.0 l

#### Mechanical - Output Details

Nominal rotation speed	2,500.0 1/min
Travel speed	30.0 km/h

#### Mechanical Details

Length	6,349.0 mm
Width	2,088.0 mm
Height	2,775.0 mm
Operating weight (min.-max.)	6,755.0 - 8,647.0 kg
Digging depth (max.)	3,895.0 mm

#### Engine

Cooling	Water-cooling
Engine type	Diesel engine
Cylinder	4.0
Cylinder capacity	2,216.0 cm3

Inclined position max.	30.0 °
Fuel	Diesel EN 590
Tank capacity	100.0 l
Effective power	45.5 KW
Nominal Engine speed	3,000.0 1/min
Operating power	45.5 KW
Operating Engine speed	3,000.0 1/min
Maximum torque	190.0 Nm
Air cleaner	Dry air filter
Battery capacity (nom. value)	88.0 Ah
Engine Manufacturer	Perkins

#### Environment Data

Sound level LpA	77.0 dB(A)
-----------------	------------

#### Chassis

Operating pressure	420.0 bar
Flow rate	144.0 l/min

#### Shipping and Storage

Shipping weight	6,471.7 kg
-----------------	------------

## Dimensions

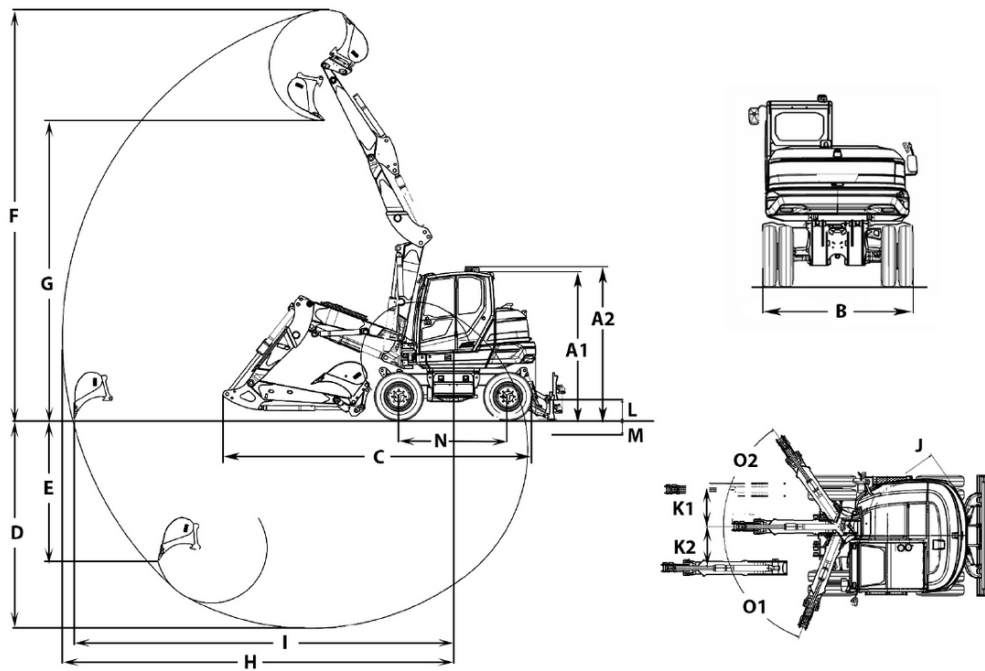

A1	Height with cab	2,775 mm
	Height of dozer blade	429 mm
A2	Total height with rotating beacon	2,952 mm
B	Width of upper carriage	1,931 mm
	Width of cab	1,000 mm
B	Width travel gear twin tires	2,088 mm
	Width travel gear single tires	1,931 mm
C	Transport length short shovel arm	6,114 mm
	Transport length long shovel arm	6,250 mm
D	Digging depth max., short shovel arm	3,531 mm
	Digging depth max., long shovel arm	3,831 mm
E	Piercing depth max., short shovel arm	2,088 mm
	Piercing depth max., long shovel arm	2,361 mm
F	Piercing height max., short shovel arm	6,068 mm
G	Dumping height max., short shovel arm	4,207 mm
	Dumping height max., long shovel arm	4,389 mm
H	Digging radius max., short shovel arm	6,220 mm
	Digging radius max., long shovel arm	6,504 mm
I	Max. reach at ground level (short shovel arm)	6,024 mm
	Max. reach at ground level (long shovel arm)	6,318 mm
J	Tail swing radius	1,459 mm
K1	Boom offset max. (to center of bucket right side)	766 mm
K2	Boom offset max. (to center of bucket left side)	492 mm
L	Stacking height max. (dozer blade above surface)	395 mm
M	Digging depth max. (dozer blade below surface)	301 mm
N	Length travel drive	2,887 mm
O1	Max. swivel angle (arm system to the left)	67 °
O2	Max. swivel angle (arm system to the right)	63 °
	Track width	300 mm
	Boom swing radius center	2,465 mm
Q2	Boom swing radius right	2,393 mm
Q3	Boom swing radius left	1,940 mm
	Distance bucket dozer blade, short shovel arm	51 mm
	Distance bucket dozer blade, long shovel arm	0 mm